



WAGO Automation Technology

Edition 2023/2024



WAGO Full Line Catalogs



WAGO Rail-Mount Terminal Blocks and Connectors

- Rail-Mount Terminal Blocks
- Rail-Mount Terminal Blocks with Pluggable Connector (X-COM®-SYSTEM)
- Patchboard Systems
- Terminal Strips
- PUSH WIRE® Connectors for Junction Boxes
- Lighting Connectors
- Shield Connecting System



WAGO PCB Terminal Blocks and Connectors

- PCB Terminal Blocks
- THR/SMD PCB Terminal Blocks
- *MULTI CONNECTION SYSTEM (MCS)*
- Pluggable PCB Terminal Blocks
- Feedthrough Terminal Blocks
- Specialty Connectors
- Empty Housings



WAGO Pluggable Connection System WINSTA®

- Pluggable Connectors
- Snap-In Device Connectors
- Pluggable PCB Connectors
- Distribution Connectors
- Cable Assemblies
- Flat Cable Systems
- Distribution Boxes



WAGO Automation Technology

- Solutions & Software
- Operating & Monitoring
- Controllers, Edge Devices
- Modular I/O-SYSTEM IP20, I/O-SYSTEM IP67
- Industrial Switches
- Radio Technology
- IP67 Sensor/Actuator Boxes, IP67 Cables and Connectors



WAGO Interface Electronics

- Relay and Optocoupler Modules
- Signal Conditioners and Isolation Amplifiers
- Current and Energy Measurement Technology
- Power Supplies
- Interface Modules and System Wiring
- Overvoltage Protection
- Empty Housings

















WAGO Power Supplies

- Power Supplies
- DC/DC Converters
- Circuit Protection
- UPS-Charger and Capacitive Buffer Modules
- Redundancy Moduls
- Current and Energy Measurement Technology
- Overvoltage Protection











WAGO Marking

- Printer
- Software
- Terminal Block Marking
- Cable and Conductor Marking
- Device Marking
- Marker Carriers

		Page		
Solutions		Solutions Cloud Solutions, Software Applications	5	1
Software		Software Engineering Software, Runtime Software, Mobile Software (Apps)	29	2
Operation & Monitoring		Operation and Monitoring Web Panels, Visu Panels and Control Panels	67	3
Edge Computing		Edge Computing Edge Controllers, Edge Computers	93	4
Controllers		Compact Controller 100	101	5
		Controllers PFC100/PFC200, PFC200 XTR, Basic Controllers, Controllers 750, Controllers 750 XTR, Starter Kits and IoT Boxes	109	6
I/O Systems		I/O System – 750 and 753 Series Fieldbus Couplers and I/O Modules (IP20)	191	7
		I/O System – 750 XTR Series Fieldbus Couplers and I/O Modules (IP20) for eXTReme Environments	479	8
		I/O System Field Fieldbus Modules, IO-Link Master, IO-Link Hub and IO-Link Converter (IP67)	549	9
Infrastructure		Industrial Switches	581	10
		Radio Technology <i>Bluetooth</i> ®, EnOcean and WLAN Components	619	11
		Sensor/Actuator Boxes M8 and M12 Passive Distribution Boxes (IP67)	633	12
		Accessories and Tools	653	13
		Technical Section	729	14
		Indexes	761	15

WAGO Automation Technology

Solutions & Software	<p>Solutions</p>  <ul style="list-style-type: none"> • Cloud solutions • Reusable, customizable software applications <p>1</p>	<p>Engineering Software</p>  <ul style="list-style-type: none"> • PC and web-based software • Customized tools for every automation task 	<p>Runtime Software</p>  <ul style="list-style-type: none"> • Standard machine component • Comprehensive, tested software modules for control, regulation, operation & monitoring 	
	<p>Operation & Monitoring Edge Computing</p>	<p>Touch Panel 600 Standard Line</p>  <ul style="list-style-type: none"> • High-performance touch panels with resistive touch-screens • 10.9 ... 54.7 cm (4.3 ... 21.5") • Models include Control, Visu or Web Panels for display of CODESYS visualizations 	<p>Touch Panel 600 Advanced Line</p>  <ul style="list-style-type: none"> • High-performance touch panels with capacitive touch-screens and glass surfaces • 18 ... 54.7 cm (7 ... 21.5") • Models include Control or Visu Panels 	<p>Touch Panel 600 Marine Line</p>  <ul style="list-style-type: none"> • High-performance touch panels with resistive touchscreens • Ideal for marine applications • 10.9 ... 25.7 cm (4.3 ... 10.1") • Models include Control or Visu Panels <p>3</p>
	<p>Controllers</p>	<p>Compact Controller 100</p>  <p>5</p> <ul style="list-style-type: none"> • Maximum performance in minimum space: • Controller with a real-time Linux® operating system • Compact controller with I/Os in a DIN-rail-mount enclosure • Manufacturer-independent CODESYS V3 engineering environment 	<p>Controllers PFC100/PFC200</p>  <p>6.1</p> <ul style="list-style-type: none"> • Maximum performance in a minimum space • Also programmable in high-level languages based on Linux® • Security packages with SSH and SSL/TLS • Runtime system for CODESYS V3 	<p>Controllers PFC200 XTR</p>  <p>6.2</p> <ul style="list-style-type: none"> • The advantages of WAGO's PFC Controllers combined with the capabilities for extreme environments: • High processing speed • Multiple interfaces • xTRemely robust and maintenance-free
<p>I/O Systems</p>	<p>I/O System – 750 and 753 Series</p>  <p>7</p> <ul style="list-style-type: none"> • Highly versatile • More than 500 modules available • Functional Safety • Ex i 	<p>I/O System – 750 XTR Series</p>  <p>8</p> <p>For demanding applications where the following are critical:</p> <ul style="list-style-type: none"> • Extreme temperature resistance • Immunity to electromagnetic interference and impulse voltages • Vibration and shock resistance 	<p>I/O System Field</p>  <p>9</p> <p>Automate and network modular machines for the future</p> <ul style="list-style-type: none"> • Ethernet-based fieldbus standards (EtherCAT®, EtherNet/IP™, PROFINET) • Integrated Bluetooth interface (Android/iOS App), OPC UA Server, Webserver • IO-Link master and devices 	
<p>Infrastructure</p>	<p>Industrial Switches</p>  <p>10</p> <ul style="list-style-type: none"> • Copper cable • Fiber optic cable • Ring redundancy 	<p>Radio Technology</p>  <p>11</p> <ul style="list-style-type: none"> • Bluetooth® • WLAN • EnOcean® 	<p>Sensor/Actuator Boxes</p>  <p>12</p> <ul style="list-style-type: none"> • M8 and M12 sensor/actuator boxes • Passive signal acquisition and output at the machine level • Fully encapsulated 	

<p>Mobile Software (Apps)</p>  <ul style="list-style-type: none"> Machine operation and monitoring on tablet and smartphone 	<p>2</p>	<p>1 Solutions</p> <ul style="list-style-type: none"> Cloud Solutions 8 Software Applications 12 <p>2 Software</p> <ul style="list-style-type: none"> Engineering Software 32 Runtime Software 48 Mobile Software (Apps) 62 		
<p>Edge Computing</p>  <ul style="list-style-type: none"> Versions include Edge Controllers or Edge Computers Perfect in-the-field data usage Easy cloud connection Equipped for high security 	<p>4</p>	<p>3 Operation and Monitoring</p> <ul style="list-style-type: none"> Touch Panels 600 Standard Line 74 Touch Panels 600 Advanced Line 80 Touch Panels 600 Marine Line 84 <p>4 Edge Computing</p> <ul style="list-style-type: none"> Edge Controllers 96 Edge Computers 97 		
<p>Basic Controllers 100</p> <p>6.3</p>  <ul style="list-style-type: none"> Freely programmable per IEC 61131-3 with CODESYS V3 HTML-5-based Web visualization Syslog in compliance with RFC 5424 and role-based user management (RBAC) Large amount of memory for projects and data 	<p>Controllers 750</p> <p>6.4</p>  <ul style="list-style-type: none"> Controllers for all prominent fieldbus systems Programmable to IEC 61131-3 Readily combine with the modules of the WAGO I/O System 750 	<p>Controllers 750 XTR</p> <p>6.5</p>  <p>6</p> <p>For demanding applications where the following are critical:</p> <ul style="list-style-type: none"> Extreme temperature resistance Immunity to electromagnetic interference and impulse voltages Vibration and shock resistance 	<p>5 Compact Controller 100 101</p> <p>6 Controllers 109</p> <ul style="list-style-type: none"> 6.1 Controllers PFC100/PFC200 111 6.2 Controllers PFC200 XTR 131 6.3 Basic Controllers 100 143 6.4 Controllers 750 151 6.5 Controllers 750 XTR 173 6.6 Starter Kits, IoT Box 181 	
<p>Starter Kits</p>  <p>To get you up and running quickly, we offer starter kits to suit the most diverse applications:</p> <ul style="list-style-type: none"> with Controller PFC100 with Controller PFC200 with Controller 750 KNX IP with Touch Panel 600 	<p>IoT Boxes</p>  <p>6.6</p> <ul style="list-style-type: none"> Ready to use Expandable, customizable hardware/software Flexible connection via ETHERNET, WLAN or mobile network 	<p>I/O Systems</p> <p>7 I/O System – 750 and 753 Series 191</p> <ul style="list-style-type: none"> 7.1 Fieldbus Couplers 201 7.2 Digital Input Modules 229 7.3 Digital Output Modules 277 7.4 Analog Input Modules 311 7.5 Analog Output Modules 361 7.6 Function/Technology Modules 377 7.7 Communication Modules 397 7.8 Functional Safety 417 7.9 Intrinsically Safe Modules 431 7.10 Supply/Segment Modules 449 <p>8 I/O System – 750 XTR Series 479</p> <p>9 I/O System Field 549</p>		
<p>Accessories Tools</p>  <p>13</p>		<p>Infrastructure</p> <p>10 Industrial Switches 581</p> <p>11 Radio Technology 619</p> <p>12 Sensor/Actuator Boxes 633</p> <p>13 Accessories 653</p> <ul style="list-style-type: none"> Power Supplies Cables and Connectors (IP67) 		



Solutions

Cloud Solutions

- "Internet of Things" (IoT) applications

Software Applications

- Reusable, customizable solutions

Solutions

Cloud Solutions, Software Applications

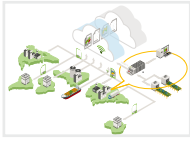

	Page
General Product Information	6
Cloud Solutions	
WAGO Cloud	8
Cloud Connectivity via MQTT	11
Software Applications	
Application "Energy Data Management"; Visualization "Energy Data Management"	12
Application „Building Control“	14
Application „flexROOM®“	16
Application „Weather Station“	18
Application „Weather Station“; Shadow Correction	19
Application „Weather Station“; Dynamic Wind Protection	19
Application "Lighting Management"; Visualization "Lighting Management"	20
Application „Grid Gateway“	22
Application „Medium Voltage Calculation“	23
Application „Customer Substation“	24
Power Plant Control Library	25
Controller Redundancy Master Library	26
Gateway Application	27

Solutions

General Product Information

1

We Make It Simple!

WAGO products are at home in many industries. Tailored solutions make it easy for the customer to accomplish the task using WAGO products – in the form of libraries and complete products, regardless of industry.

Cloud Solutions

Digitalization and networking offer great opportunities for every company. To use them, every company has to do its homework – in fact, the challenges are just as varied and diverse as the companies themselves. While there is no such thing as an all-in-one solution, smart products, methods and partners will help you advance digitalization in your business in a way that benefits all involved.

WAGO shapes the digital future with you. Cloud solutions have become popular industry staples. They link the real and digital worlds, allow efficient use of production-related data and simplify cross-site networking of global communication structures. This creates many new opportunities for the manufacturing industry – especially for plant availability and process optimization.



Member of **WAGO** Group

Scalable Solution Thanks to Our Reliable Partner

With M&M as a member of the WAGO Group, WAGO has a partner for holistically developing industrial and technical software solutions, which also allows customer-specific applications to be implemented. We collaborate closely with Microsoft to implement corresponding solutions in the cloud and IoT, primarily using Azure.

Application Software

Prepared applications make it easy to use WAGO products. We offer a range of complete industry-specific solutions such as *flexROOM*®, that dramatically shorten time to completion. But also industry-independent universally usable solutions are available (closed or adaptable) and are optimally adapted to the respective hardware.

Standardized Applications

The better prepared, the easier it gets. For many applications, we offer configuration via web browser with a standard PC without special software. Thanks to a flexible software architecture, it is also possible to realize individual configurations. Here we combine the advantage of reusing a standardized and field-proven solution with customization via parameterization instead of individual programming. This saves costs by shortening the time required and makes commissioning easy!

Tailor-Made Applications

If a standard solution does not fit, we can create a highly tailored, customer-specific approach that's as unique as your application. Start by contacting us, we'll be happy to assist you.

Your Benefits:

- Solutions for digitalization
- Support for Industry 4.0/Internet of Things (IoT)
- Prepared field-tested applications for solving standard requirements in various industries
- Support with individual adjustments

Solutions

General Product Information

Cloud Solutions

WAGO's universal cloud solutions are suitable for a wide variety of applications. These solutions offer:

WAGO Cloud:

- Collecting and saving data
- Setting up individual dashboards
- Central condition monitoring and alarm handling
- Central data visualization via location-independent access

Cloud Connectivity:

- Establishing connections
- Secure communication

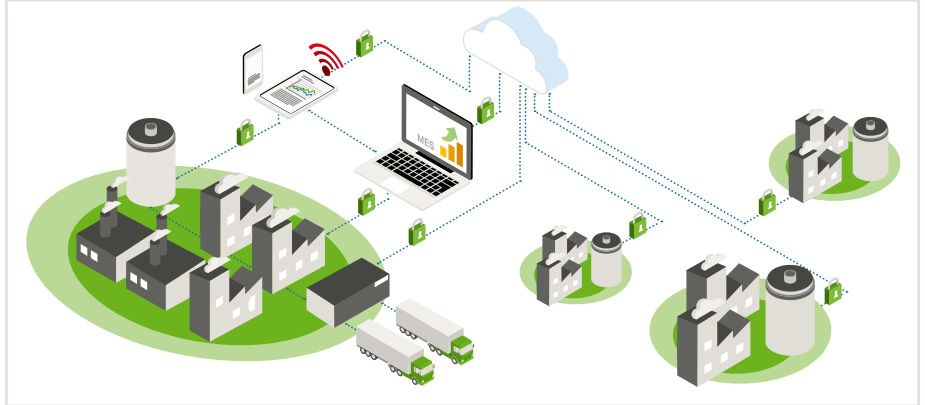

Application Software – Industry-Independent Solutions

Many solutions can be used regardless of industry, such as our energy management. For our modular energy data acquisition, we rely on an open and flexible system that you can easily install and extend. It doesn't matter if you are looking for an individual solution or want to use our standard solution.



Building Automation

Whether you are planning lighting installations and automation in your office building, retrofitting a heating, ventilation and air-conditioning system or involved with room automation, WAGO helps implement your requirements in buildings, both in office and administrative buildings, as well as in production and warehouses, retail or infrastructure buildings.



Power Engineering

Energy suppliers need to change the way they think. Instead of merely selling green energy, they also need to organize and market the flexibility that is required for maintaining stability on the electrical grid. This means that the energy system needs to be controllable from production to consumption using intelligent communication networks. WAGO supports digitizing the energy sector and designing smart grids with state-of-the-art control and measurement technology, along with software solutions that enable a simple and secure connection to the cloud.



WAGO Cloud

Collect, Analyze and Manage Data Centrally

WAGO Cloud lets you collect and centrally manage data from various machines.

It also allows you to manage and monitor WAGO's controllers along with their data and applications. WAGO Cloud is hosted on Microsoft's Azure Cloud. Combining simplicity with usability, WAGO Cloud was designed so that people without IT experience can use it.

The cloud service is available online at <https://cloud.wago.com/>. After registering for free and linking to WAGO's controllers, you can get started in just a few minutes.

How does machine data get to WAGO Cloud?

A WAGO PFC Controller or Touch Panel acts as a gateway, collecting and sending data to WAGO Cloud. Users log into their user interface on the Web portal, where they can use various applications and access functions like visualizations, controller and user management and status monitoring. They can also activate alarm functions and use them to automatically send email notifications if defined limit values are exceeded, for example. Data can be graphically visualized, evaluated and exported as needed.

Do you need to restrict and select what data is sent to the cloud? No problem! Configure the WAGO PFC Controller and specify what data to send to the cloud (or not) via IEC programming.

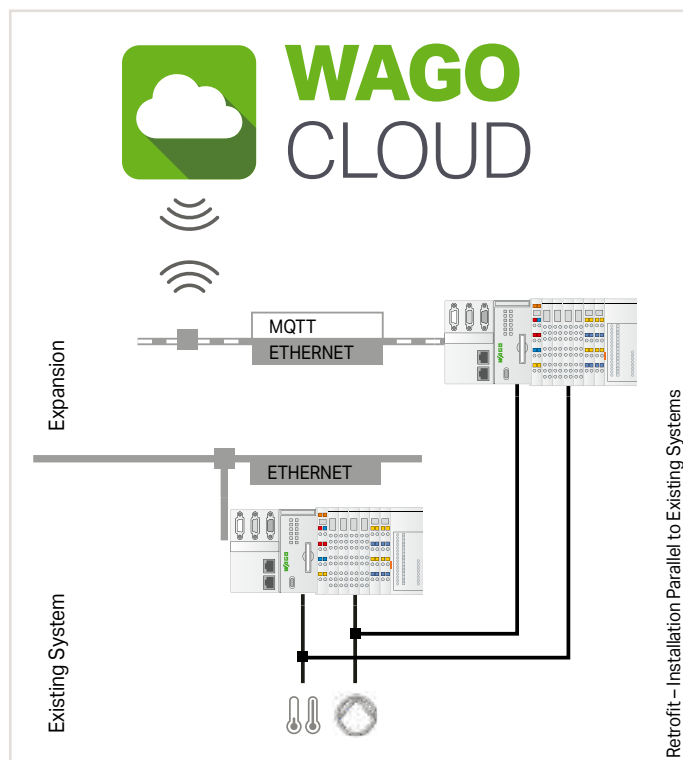

Illustrations: Data Transfer to WAGO Cloud

The WAGO PFC Controller acts as a gateway for existing systems that it can easily expand. Various protocols allow the controller to collect and transmit data to the WAGO Cloud via TLS-encrypted MQTT connection. If a new system is installed and the WAGO PFC Controller is used, it can send the data directly to the cloud.

What advantages does WAGO Cloud offer?

• Simplicity

The solution is intuitive thanks to a clear functional range. Within minutes, you can send data to the cloud, without extensive IT expertise.

• Flexibility

Customize your cloud solution at any time and from any place. For instance, you can double your number of controllers from one day to the next without affecting performance and availability. Would you like a special expansion? We offer that as a project service through customized cloud expansions.

• Everything from a Single Source

Take advantage of the benefits of WAGO Cloud – software as a service. Save time by leaving the tasks of infrastructure, security platform and application management to WAGO.

WAGO Cloud

App Overview:

All functions at a glance thanks to an intuitive app structure

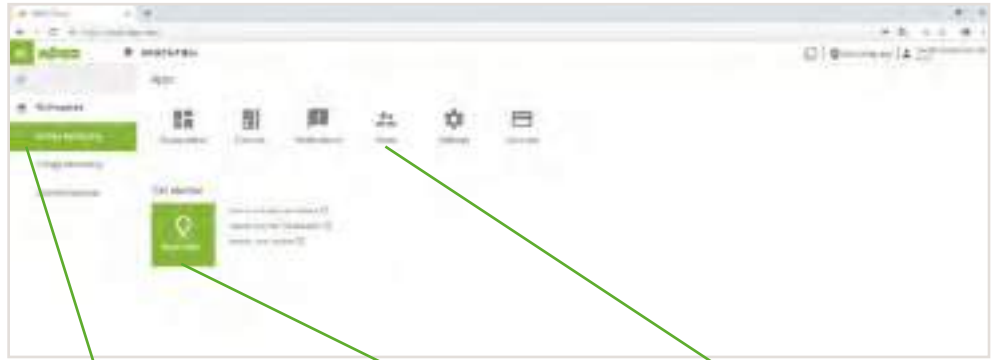

Quick Access:

- Quickly discover what you are looking for – you have all your workspaces in view.

Easy to Use:

- Let us guide you in creating cloud projects.

Relevant Functions:

- Only see the features that you have access to.

Controller Status Overview:

See your connected and disconnected controllers, as well as relevant connection details.

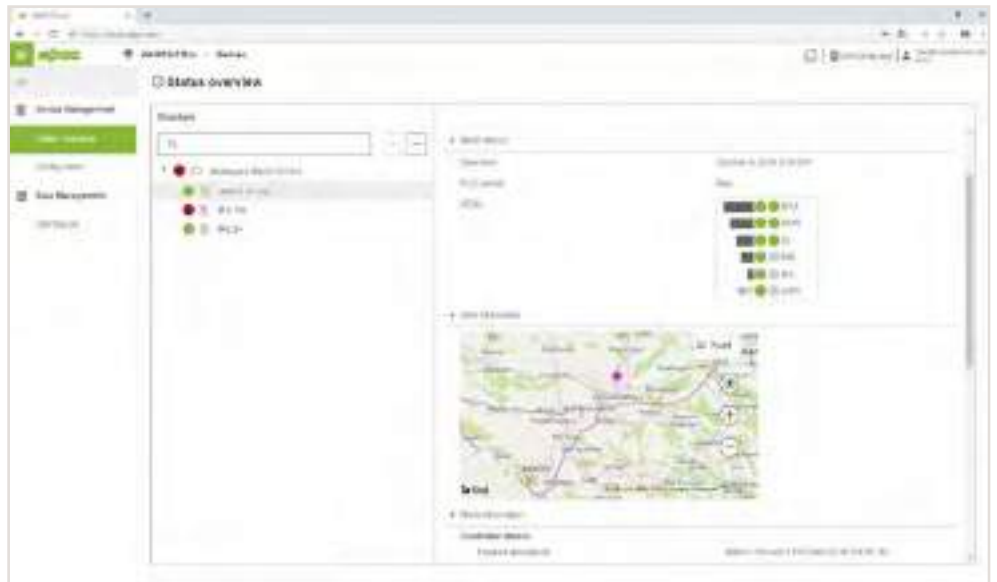

Dashboard:

Create your own custom dashboard, use both graphics and trends.



1

WAGO Cloud

What kind of services can I use on WAGO Cloud?

WAGO Cloud is a universal, industrial-strength data logger with data visualization. It allows customizable dashboards and analyses to be created quickly and easily in the cloud. Use interfaces via REST and CSV data export for further processing of data, or use them as a data supplier to perform detailed analyses in other systems, for example. Monitor controller statuses and receive notifications if specified limit values are exceeded.

How can I use the functions?

Try WAGO Cloud for 30 days with no commitment to see if it's right for you.

The cloud service is available online at <https://cloud.wago.com/>. After registering for free and linking to WAGO's controllers, you can get started in just a few minutes.

After that, you book license points with a prepaid model, via our WAGO eShop for example, and simply redeem them in the cloud. Transparent billing management in the cloud allows you to fully monitor the current and anticipated scope of the functions used. When your license points are almost depleted, you will receive a notice to reload your points account soon.

You can find an overview of the functions we currently offer in the following table. There are various tiers for each individual function – depending on how many components you need – such as the number of connected controllers.

Trial Period		<ul style="list-style-type: none"> • Try WAGO Cloud for free for 30 days (limited test points). • Points account may be exceeded after the trial period. 	
Functions			
Data Management	Data Package	<ul style="list-style-type: none"> • Connect the WAGO PFC Controller to the cloud. • Transfer data from the controller to the cloud. • Mount devices and data. • Visualize data. 	<ul style="list-style-type: none"> • Basic package, required for using WAGO Cloud • Minimum purchase: 50 license points/month • Volume-dependent, decreasing license point consumption
	Restful API	<ul style="list-style-type: none"> • Provide data for other cloud services and customer systems. 	<ul style="list-style-type: none"> • Volume-dependent, decreasing license point consumption
Device Management	Firmware & Application Update	<ul style="list-style-type: none"> • Select/download firmware catalog. • Manage your own firmware application catalog. • Replace firmware on the device. • Install application updates. 	<ul style="list-style-type: none"> • 1 license point/update
	Remote Visu Access	<ul style="list-style-type: none"> • Access local configurations and visualizations remotely (diagnostics, monitoring and remote maintenance). 	<ul style="list-style-type: none"> • 10 license points/hour
	User Management	<ul style="list-style-type: none"> • In a customer area, up to 10 users have free access. More can be booked upon request. 	

Item Description	
	Item No.
WAGO Cloud; 100 license points	2759-1061/651-010
WAGO Cloud; 500 license points	2759-1061/651-050
WAGO Cloud; 1000 license points	2759-1061/651-100

Redeem license points at: <https://cloud.wago.com/>

Cloud Connectivity via MQTT

Recording, digitizing and linking data profitably...

...this is the core concept behind Industry 4.0. Field level connection is established with the open WAGO I/O System 750, 750 XTR or Advanced, and a WAGO PFC Controller or Touch Panel 600 sends data to the cloud or a local MQTT broker. Once in the cloud, data can be aggregated and used for analysis. This capability creates tremendous added value for your company – whether it's increasing the efficiency of in-house production, implementing energy management in buildings or developing additional end-customer services.

Existing systems also become IoT-ready, making them future-proof. Communication between PFCs and cloud suppliers is performed via the MQTT protocol and encrypted via TLS 1.2.

Cloud connection data is configured via Web-Based Management (WBM). WAGO Engineering includes appropriate libraries for specifying the variables for transfer to the cloud in the PLC program, allowing the PLC programmer to maintain complete control. Controller information, such as run/stop, connection status and device information, can also be transferred to a cloud solution with cloud connectivity or distributed via MQTT broker.

With a wide variety of interfaces, WAGO's controllers also provide the perfect foundation for an IoT gateway.

They can collect numerous field signals, communicate in many industrial protocols and even enable cloud connection of sensors and actuators that themselves have no Web interface. Thanks to the standardized MQTT protocol, it is possible to connect to cloud providers such as Microsoft Azure, Amazon Web Services, IBM Cloud and SAP Cloud. Of course, other MQTT brokers or solutions like WAGO Cloud can also be connected.



Cloud connectivity is possible with all PFC100 and PFC200 Controllers, Touch Panels 600, Compact Controller and Edge Devices.

WAGO Energy Data Management

1

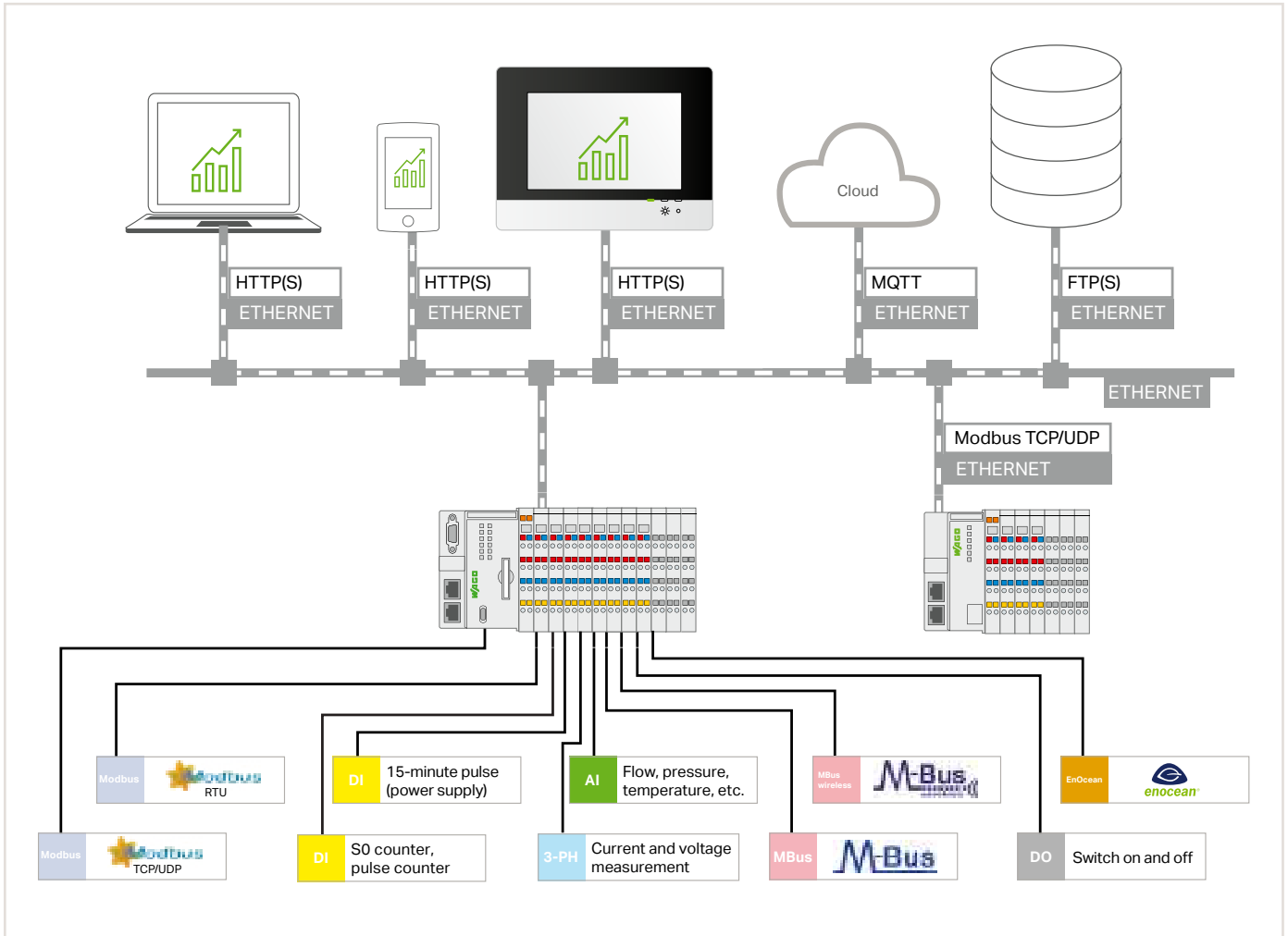

With WAGO's Energy Data Management solution, you can record and visualize your measurement data for different media and influencing variables (as well as the key figures calculated from it) in no time. Continuous acquisition and monitoring provide the basis for resource-efficient energy usage – the environment will thank you, and your operating costs will be minimized. As an added bonus, conformity with DIN EN 50001 for energy evaluation is part of the package.

WAGO Energy Data Management consists of Web-based application software combined with a modular control system. It records measurement data for different media along with influencing variables for energy monitoring –

all are processed for additional analysis, archiving and reporting. The software automatically detects different signals from the connected meters and sensors, making them available to additional energy analysis tools via simple parameter settings. This insight guides you in optimizing energy consumption in your building or production facility – either locally or across the globe.

Your Benefits:

- Ready to go in a few easy steps
- No programming experience required
- Integrated cloud connectivity

Item Description	Item No.
Energy Data Management Application; Single License; Online Activation	2759-206/261-1000
Energy Data Management Visualization; Single License; Online Activation	2759-207/271-1000
Compatible Controllers/Touch Panels	
Controller PFC200; G2	750-821x
Controller PFC200; G2; XTR	750-821x/000-040
Touch Panel 600 Standard Line; PIO3	762-43xx/8000-002
Touch Panel 600 Advanced Line; PIO3	762-53xx/8000-002

Delivery type	License certificate by email (software available for download)
Data sheet and additional information, see:	wago.com/2759-206/261-1000 wago.com/2759-207/271-1000 wago.com/energy-data-management

The "Energy Data Management" software is a pre-programmed application based on the CODESYS Development Environment and can be used for both PFC200 G2 Controllers or Touch Panels 600.

To download the application and license to the device, WAGOupload software is required, which can be obtained free of charge from the WAGO homepage. Internet connection may be required for license activation.

A single license allows installation on one controller/touch panel. One license per controller/touch panel is required.

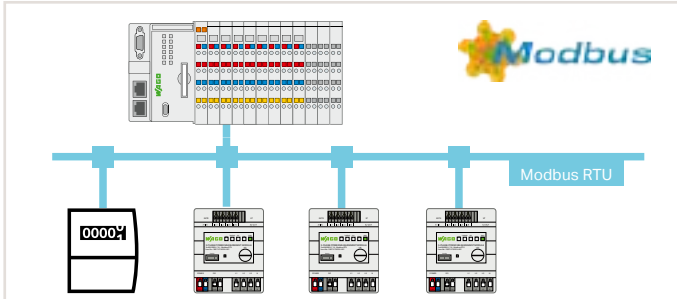

Energy Data Collection with Remote Devices via Modbus RTU

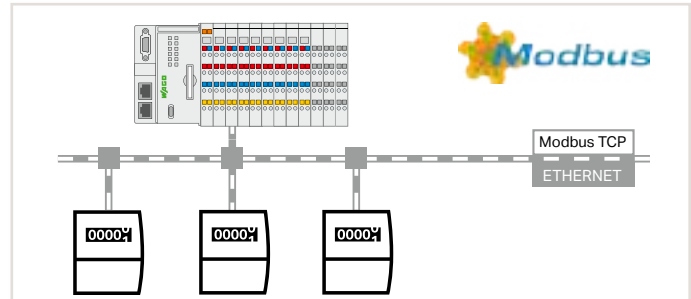

Energy Data Collection with Remote Devices via Modbus TCP

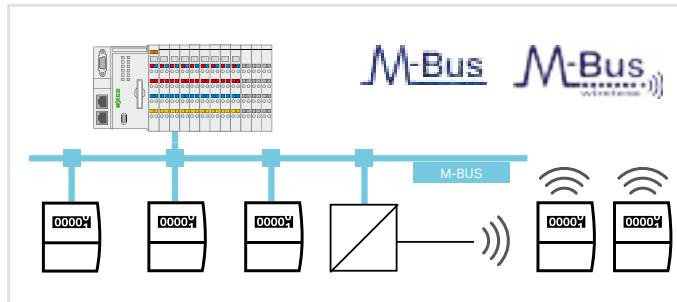

Measured Value Acquisition via M-Bus

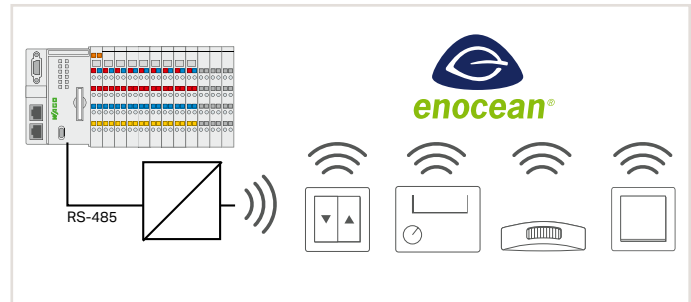

Data Acquisition via EnOcean®

The products listed below are typically used in conjunction with the "Energy Data Management" Application. Detailed information about the products, as well as other variants and accessories, can be found in our Full Line Catalog, Volume 3 or Volume 4.

Energy Data Management		
Required Products	Description	Item No.
Software Licenses		
WAGO Cloud; 100 license points	Licenses to use WAGO Cloud as a data collector with data visualization; the number of required	2759-1061/651-010
WAGO Cloud; 500 license points	license points depends on the functions used and the data volume (for details see www.wago.com/	2759-1061/651-050
WAGO Cloud; 1000 license points	cloud).	2759-1061/651-100
Digital I/O Modules		
4-Channel Digital Input; 24 VDC; 3 ms	E.g., for recording the PSC effective power pulse	750-402
4-Channel Digital Output; 24 VDC; 0.5 A	E.g., for switching outputs when alarm thresholds are reached	750-504
8-Channel Digital Output; 24 VDC; 0.5 A		750-530
Analog I/O Modules Recording temperature, pressure, flow meters and other analog signals		
8-Channel Analog Input; Resistance Measurement; Adjustable		750-451
8-Channel Analog Input; 0/4 ... 20 mA; Single-Ended		750-496
8-Channel Analog Input; 0 ... 10 VDC/±10 V; Single-Ended		750-497
2-Channel Analog Input; 0 ... 20 mA; Differential Input		750-452
4-Channel Analog Input; Voltage/Current; Differential Input; Electrically Isolated Channels		750-471
Power Measurement Modules Power measurement directly connected to the controller		
3-Phase Power Measurement Module; 480 VAC; 1 A	With split-core or plug-in current transformers	750-494
3-Phase Power Measurement Module; 690 VAC; 1 A	With split-core or plug-in current transformers	750-495
3-Phase Power Measurement Module; 690 VAC; 0.5 A	With split-core or plug-in current transformers	750-495/000-001
3-Phase Power Measurement; 690 VAC; RTC	With Rogowski coils	750-495/000-002
Communication and Technology Modules		
M-Bus Master	Reading in separately recorded meter readings via M-Bus	753-649
RS-232/RS-485 Serial Interface	Reading in data via RS-232 or RS-485 gateways (e.g., EnOcean®)	750-652
2-Channel Up/Down Counter; 24 VDC; 16-bit; 500 Hz	Recording S0 and pulse counters	750-638
Power Supplies		
Compact Power Supply; Switched-Mode; 1-Phase	24 VDC output voltage; 2.5 A output current	787-1012
Pro 2 Power Supply; 1- or 3-Phase	24 VDC output voltage; 5 ... 40 A output current	2787-2xxx
Distributed Power Measurement Modules For distributed energy acquisition via Modbus RTU		
3-Phase Power Measurement Module; Input: Current Transformer (1 A)		2857-570/024-001
3-Phase Power Measurement Module; Input: Current Transformer (5 A)		2857-570/024-005
3-Phase Power Measurement Module; Input: Rogowski Coil		2857-570/024-000
Gateways		
STC65-RS-485 EVC EnOcean® Receiver/Sender with RS-485 EVC Interface	Gateway for the acquisition of EnOcean® signals	2852-7101
WLAN ETHERNET Gateway; 2.4 GHz	Gateway for creating wireless ETHERNET connections	758-916

WAGO Application Building Control

1

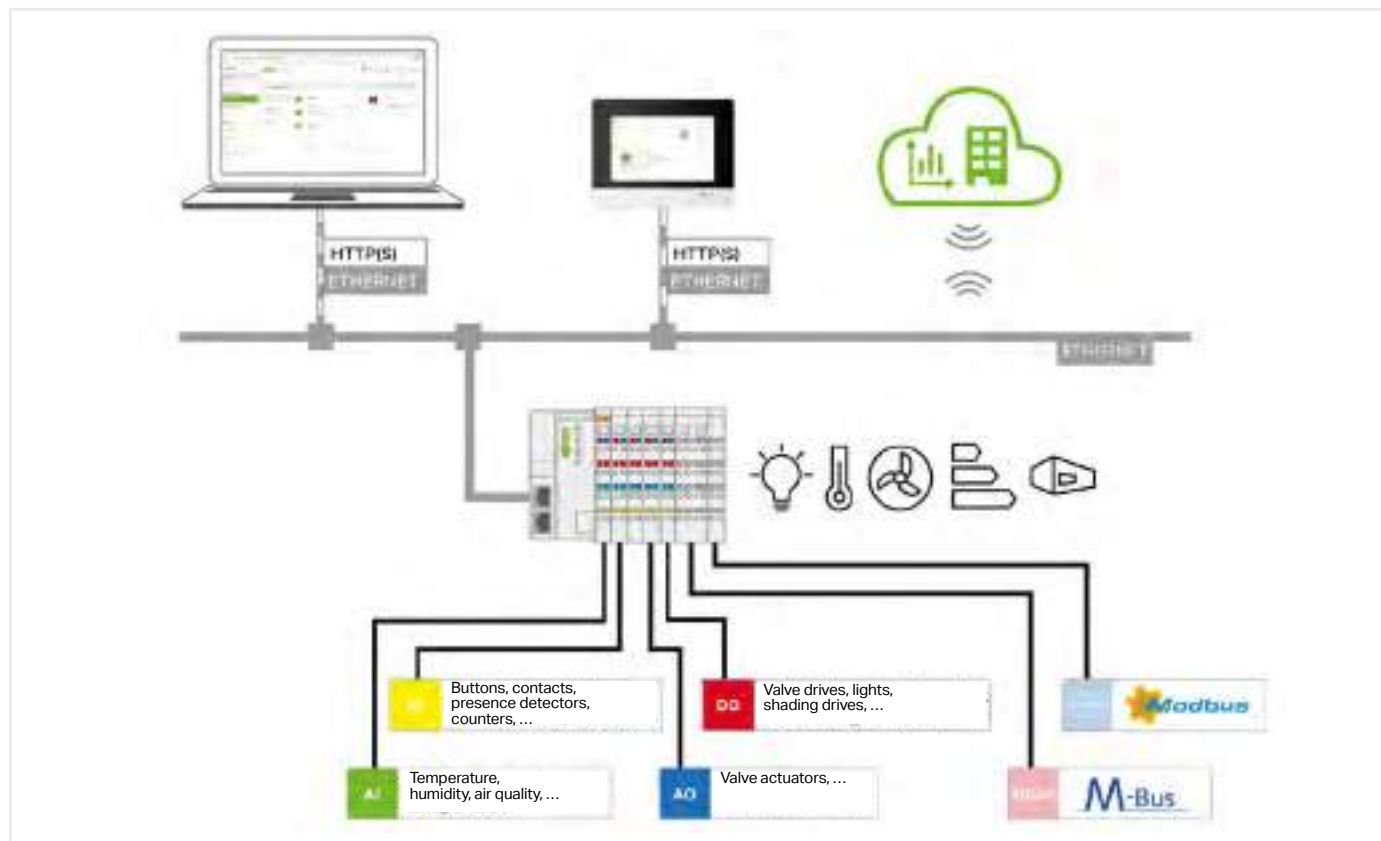

WAGO Application Building Control is a pre-programmed software solution for building automation applications.

- The application is ideal for virtually all building automation functions, such as lighting control, HVAC control, and energy data management.
- Despite pre-programming, it is possible to define almost any data points that can be linked together, put into dependency with each other or provided with control and regulating functions.
- The application has an integrated dashboard for advanced visualization options.
- Commissioning is performed through a configuration interface, following the design principle of "configuration instead of programming."

Advantages:

- Easy configuration, commissioning and operation without programming knowledge
- Highly versatile
- High flexibility and scalability for adapting to different needs
- Integrated monitoring, alarming for limit violation and status monitoring
- Optional connection to WAGO's "Cloud Building Operation and Control" cloud solution for access to all of the data from anywhere in the world

Benefits:

- High cost efficiency and profitability thanks to quick and easy commissioning
- User-friendly and intuitive visualization and operation
- High functional safety and reliability thanks to pre-programmed and tested functional units

Item Description	
	Item No.
WAGO Application Building Control; Single License; Online Activation	2759-2120/261-1000
Compatible Controllers	
Controller PFC200; G2; 2ETH RS	750-8212

Delivery type	License certificate by email (software available for download)
For data sheet and additional information, see:	wago.com/2759-2120/261-1000

The "WAGO Application Building Control" software is a pre-programmed application based on the CODESYS Development Environment and can be used for PFC200 G2 Controllers.

To download the application and license to the device, WAGOupload software is required, which can be obtained free of charge from the WAGO homepage. Internet connection may be required for license activation.



Configuration Screen

Data point catalog

- Central list of all configured data points (inputs, outputs, functions, dashboard elements)
- The input value, e.g., for a function or an output is selected from the data point list.
- Search function for finding the desired data point (helpful for long lists of larger applications)



Dashboard

The integrated dashboard offers a freely configurable visualization interface for the display of current system values and states and the possibility of operator interventions

The I/O modules (type and number) connected via the local bus are automatically detected and displayed in the application for further configuration.

WAGO Application Building Control		
Supported I/O modules as interfaces for the connection of sensors and actuators		Item No.
Quantity 10	Digital Input Modules	
	2-Channel Digital Input; 230 VAC	750-405
	4-Channel Digital Input; 24 VDC; 3 ms	750-402
	4-Channel Digital Input; 120/230 VAC	753-440
	8-Channel Digital Input; 24 VDC; 3 ms	750-430
	8-Channel Digital Input; 24 VDC; 3 ms; 2-Wire Connection	750-1415
	16-Channel Digital Input; 24 VDC; 3 ms	750-1405
10	Analog Input Modules	
	2-Channel Analog Input; for Pt100/RTD Resistance Sensors	750-461
	2-Channel Analog Input; 4 ... 20 mA; Single-Ended	750-466
	2-Channel Analog Input; 0 ... 10 VDC; Single-Ended	750-467
	4-Channel Analog Input; 4 ... 20 mA; Single-Ended	750-455
	4-Channel Analog Input; 0 ... 10 VDC; Single-Ended	750-459
	4-Channel Analog Input; Voltage/Current; Differential Input; 16 Bits; Diagnostics	750-471
10	Analog Temperature Input Modules	
	8-Channel Analog Input; Resistance Measurement; Adjustable	750-451
	4-Channel Analog Input; Resistance Measurement; Adjustable	750-450
10	Digital Output Modules	
	4-Channel Digital Output; 24 VDC; 0.5 A	750-504
	2-Channel Relay Output; 250 VAC; 1 A; Potential-Free; 2 Changeover Contacts	750-517
	8-Channel Digital Output; 24 VDC; 0.5 A	750-530
	8-Channel Digital Output; 24 VDC; 0.5 A; 2-Wire Connection	750-1515
	16-Channel Digital Output; 24 VDC; 0.5 A	750-1504
10	Analog Output Modules	
	2-Channel Analog Output; 0 ... 10 VDC	750-550
	2-Channel Analog Output; 0 ... 10 VDC; 10 Bits; 100 mW/24 V	750-560
	4-Channel Analog Output; 0 ... 10 VDC	750-559
	8-Channel Analog Output; 0 ... 10 VDC/±10 V	750-597
4	RS-232/485 Serial Interface Modules	
	Serial Interface RS-232/485	750-652
4	M-Bus Modules	
	M-Bus Master	753-649

WAGO *flexROOM*® Application

A Flexible Room Solution



Our Solution

Planning, commissioning and building operation must demonstrate maximum efficiency and a high degree of adaptability. Pre-configured programs and pre-defined hardware significantly streamline planning and commissioning. The more applications created within a project, the greater the benefit. Flexible building operation (e.g., conversions and room remodeling) via special maintenance programs eliminates external service costs because the user can make their own changes.

Install, commission and configure according to project specifications – WAGO *flexROOM*® combines these strengths into a standard module. The integrated control unit and application software are precisely tailored to room requirements.

Parameter Setting

For each room, parameters can be individually stored for lighting, shading and room control. All parameters are cyclically saved either directly in the distribution box or on a separate computer via network connection. A higher-level management station accesses the distribution box parameters via the open Modbus TCP/IP protocol. This ensures that all modifications can be implemented on site or via the management station. BACnet or KNX IP systems can also be connected via Modbus TCP/IP.

Configuring – Not Programming

Each WAGO *flexROOM*® Distribution Box has a Web interface. Both the commissioning technician and end user can configure the controls for each room via Web browser, regardless of the user's location and the distribution box in use. Complete wall relocations, room assignments, lighting and shading groups can be changed from the parameter interface. No additional software is required.

Item Description	Item No.
<i>flexROOM</i> Application; Single License; Online Activation	2759-2110/261-1000
Compatible Controller	
Controller PFC200; G2; 2ETH RS	750-8212

Delivery type	License certificate by email (software available for download)
Data sheet and additional information, see:	wago.com/2759-2110/261-1000 wago.com/room-automation

The "*flexROOM*" software is a pre-programmed application based on the CODESYS Development Environment and can be used for PFC200 G2 Controllers.

To download the application and the license to the device, the WAGOupload software is required, which can be obtained free of charge from the WAGO homepage. Internet connection may be required for license activation.

A single license allows installation on one controller.
One license per controller is required.



Benefits:

The distribution box is delivered ready to operate and can be installed directly in a suspended ceiling or a sub-floor. Room segment configuration is performed directly in the distribution box via standard Web browser. No expert knowledge is required to configure rooms or convert them later. Several *flexROOM*® Distribution Boxes can be wired into a building automation network via ETHERNET to automate a building area, a floor or an entire office section. A standard Web browser also establishes communication between the distribution boxes. If electrical distribution boxes are present, *flexROOM*® components can also be installed or retrofitted during facility renovation. Space conversion costs are reduced with *flexROOM*® because expenses are transparent and predictable.

Room Automation Distribution Boxes

Type	Office Areas (Segments)				Special-Use Areas (Segments)				Item No.
	Quantity	Valves	Lighting	Sun Protection	Quantity	Valves	Lighting	Shading	
Type 1	16	8 (MP Bus)	64 (DALI)	16 (SMI)					2854-301/000-011
Type 2	16	8 (MP Bus)	64 (DALI)	16 (SMI)	8	8 (MP Bus)	64 (DALI)	16 (SMI)	2854-301/000-021
Type 3	16	8 (DO)	64 (DALI)	16 (relays)					2854-301/000-031
Type 4	16	8 (DO)	64 (DALI)	16 (relays)	4	4 (DO)	4 (relays)	4 (relays)	2854-301/000-041
Type 5	16	8 (DO)	64 (DALI)	16 (relays)	4	4 (DO)	64 (DALI)	4 (relays)	2854-301/000-051
Type 6	8	4 (DO)	64 (DALI)	8 (relays)					2854-301/000-061
Type 7	24	24 (MP Bus)	128 (DALI)	32 (SMI)	8	8 (MP Bus)	64 (DALI)	16 (SMI)	2854-301/000-071

All distribution boxes include an EnOcean® interface to accommodate room control units, sensors and buttons.

flexROOM® Application

Required Products	Description	Item No.
Controllers		
Controller PFC200 G2 2ETH RS	Powerful IP controller, expandable with I/O modules and communication modules	750-8212
Serial Interface Module RS-232/RS-485	Connects to devices with a serial interface (e.g., weather sensors, EnOcean receivers)	750-652
End Module	Properly terminates the I/O bus	750-600
Power Supply 24 VDC, 2.5 A	Supplies both controllers and modules	787-1012
I/O Modules		
Digital Input Modules	Connect to push-buttons, switches and sensors with a potential-free contact	75x-4xx, 750-14xx
Digital Output Modules	Connect to digital actuators and relays	75x-5xx, 750-15xx
Relay Module	For lamp loads	788-354
Relay Module	For sunblind actuators	788-304
Analog Input Modules	Connect to sensors with analog output signal (0 ... 10 V)	75x-4xx
Analog Output Modules	Connect to actuators with analog control signal (0 ... 10 V)	750-5xx
DALI		
DALI Multi-Master Module	Connects to a maximum of 64 DALI actuators (ECGs) and a maximum of 16 DALI multi-sensors (max. 64 sensor addresses)	753-647
DALI Multi-Master DC/DC Converter	Supplies (24 VDC/18 VDC) one DALI Multi-Master Module	753-620
Power Supply to DALI Multi-Master	Supplies a maximum of five DALI Multi-Master Modules	787-1007
DALI-2 Certified Sensors and other DALI Sensors	DALI compatibility list available at www.wago.com/room-automation	
SMI		
SMI-Master	Connects to a maximum of 16 SMI drives (230 VAC)	753-1630
SMI-Master LoVo	Connects to a maximum of 16 SMI low-voltage drives (24 VDC)	753-1631
MP-Bus		
MP-Bus Master Module	For connecting valve and damper actuators with an MP-Bus interface	750-643
EnOcean		
EnOcean Receiver	Receiver with serial interface for EnOcean switches, sensors and room control units	2852-7101
EnOcean Repeater	Improves coverage – further information on planning can be found at www.enocean.com	2852-7102
EnOcean®-RS-485-Gateway		750-940
EnOcean Light Push-Button (2 Channels)	For one light circuit	758-940/001-000
EnOcean Light Push-Button (4 Channels)	For two light circuits	758-940/003-000
EnOcean Sunblind Button (2 Channels)	For one blind	758-940/002-000
EnOcean Sunblind Button (4 Channels)	For two blinds	758-940/004-000
EnOcean Room Control Unit, SR04 P	With integrated temperature sensor and rotary wheel for setpoint correction, for surface mounting	2852-7112
EnOcean Room Control Unit with LCD, SR06-LCD	With integrated temperature sensor and buttons for setpoint correction, for 55 x 55 switch programs	2852-7113
KNX		
KNX TP1 Module	Connects to KNX TP1 components (e.g., room control units and buttons)	753-646
M-Bus		
M-Bus Master Module	For connecting energy meters with an M-Bus interface	753-649

WAGO Application Weather Station

1

The WAGO Weather Station makes data from the connected weather sensors (e.g., temperature, precipitation, wind speed and light intensity) available on a network for further processing and display in visualization or a management system.

It also provides central functions such as weather protection and automated glare protection.

Weather protection prevents damage to exterior sun protection fixtures (e.g., blinds, awnings, curtains) due to wind, rain or ice formation. Dynamic wind monitoring is available as an option, which selectively ensures and improves protection against wind damage according to an existing object-specific wind analysis.

The glare protection automation based on the position of the sun (slat tracking) simultaneously ensures that the maximum amount of daylight is allowed into the rooms and also avoids glare. For this purpose, the WAGO Weather Station calculates the exact position of the sun, records its intensity with the help of connected light intensity sensors and cyclically adjusts the position of the blinds. Additional optimization of the daylight supply is provided by the optional shading correction. It takes the shading caused by surrounding buildings and vegetation into account according to an existing shading analysis for the specific property.

The WAGO Weather Station solution consists of a web-based application software and a modular I/O system. In addition to simple commissioning, the system distribution box design paired with the WAGO WINSTA® Pluggable Connection System guarantees fast and safe installation.

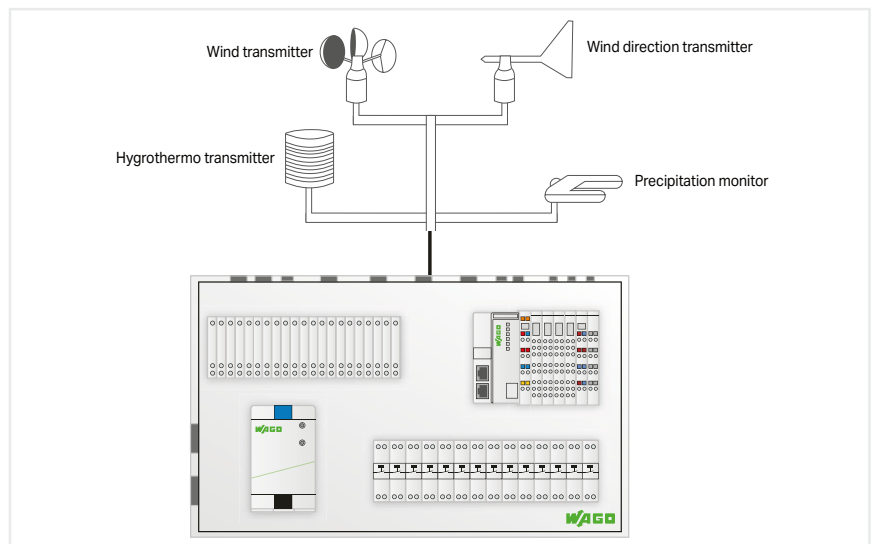
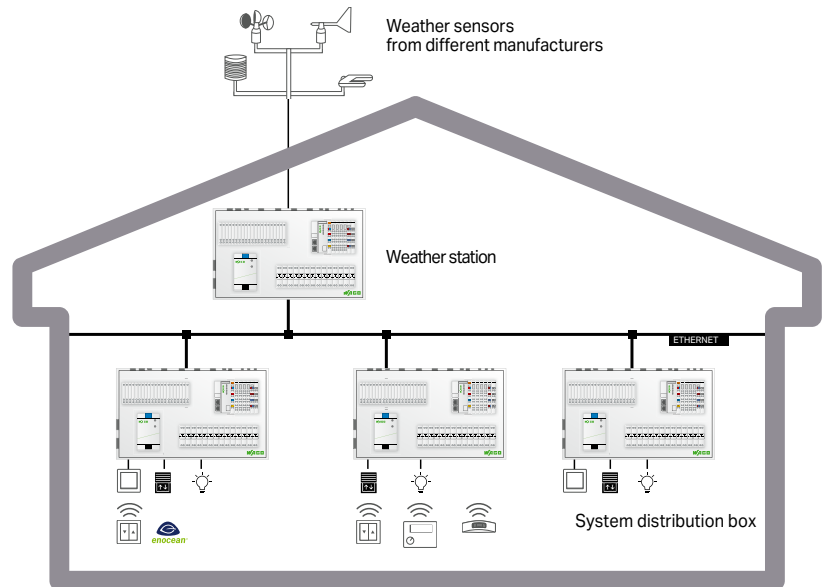

Weather Distribution Box		Signals (Inputs)											Item No.	
Description	Equipment	Digital (24 VDC)			Analog (4 ... 20 mA)						Serial Interface			
		Precipitation monitor	Sun protection (central (UPI))	Real-time clock	Temperature	Relative humidity	Wind sensor (central)	Additional wind sensors	Wind direction	Brightness sensor (single)	Twilight sensor	Global radiation (pyranometer)		Modbus® interface (combi sensor connection)
Weather distribution box (type 1)	Analog and digital inputs	1	1	1	1	1	1	8	1	1	1	1		2854-302/000-011
Weather distribution box (type 2)	Modbus®, digital inputs		1										x	2854-302/000-021
Weather distribution box (type 3)	Modbus®, analog and digital inputs		1					3				1	x	2854-302/000-031

Item Description	Item No.
Application Weather Station; Single License; Online activation	2759-241/261-1000
Compatible Controllers	
Controller PFC200; G2; 2ETH RS	750-8212

Delivery type	License certificate by email (software available for download)
For data sheet and additional information, see:	wago.com/2759-241/261-1000

The „Application Weather Station“ software is a pre-programmed application based on the CODESYS Development Environment and can be used for PFC200 G2 Controllers.

To download the application and license to the device, WAGOupload software is required, which can be obtained free of charge from the WAGO homepage. Internet connection may be required for license activation.

A single license allows installation on one controller. One license per controller is required.

WAGO Application Weather Station

The "Shadow Correction" function extends the sun position-dependent slat tracking and additionally optimizes the supply of daylight in the rooms. It takes the shading caused by surrounding buildings and vegetation into account according to an existing shading analysis for the specific property. As a result, only the blinds that are actually in the sun are adjusted to the sun's position. Blinds of the shaded windows can be raised, or their slats can be set in a horizontal position, to improve the supply of sunlight in the room, increasing workplace comfort.

Note:

This is an additional function for the WAGO Application Weather Station. A license is required for productive use of the "Shadow Correction" function without time restriction. The full scope of this function can be used for evaluation without a license for 30 days.

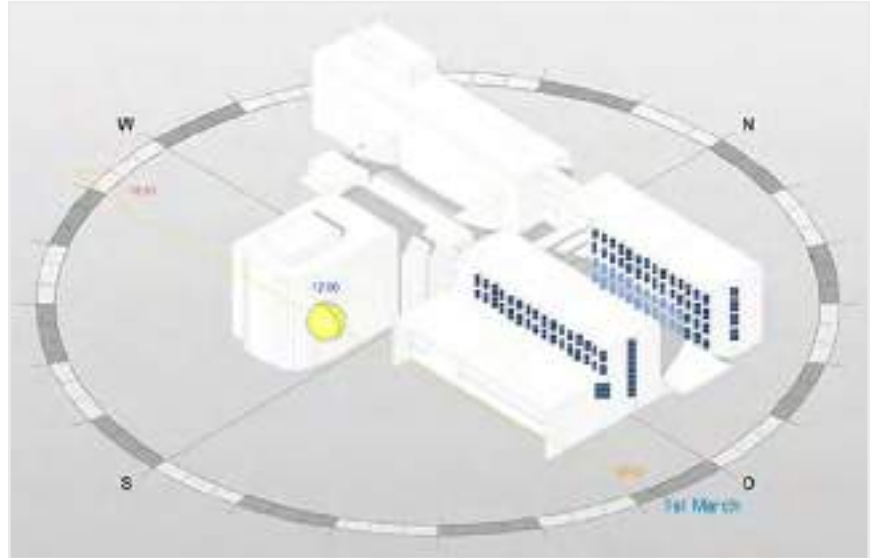

Item Description	
	Item No.
Application Weather Station; Shadow Correction; Single License; Online activation	2759-242/261-1000
Compatible Controllers	
Controller PFC200; G2; 2ETH RS	750-8212

A single license allows installation on one controller. One license per controller is required.

Delivery type	License certificate by email (software available for download)
For data sheet and additional information, see:	wago.com/2759-242/261-1000

The "Application Weather Station; Shadow Correction" software is a pre-programmed application based on the CODESYS Development Environment and can be used for PFC200 G2 Controllers.

To download the application and license to the device, WAGOupload software is required, which can be obtained free of charge from the WAGO homepage. Internet connection may be required for license activation.

Typical weather protection functions move all the building's shades into a safe position and lock them there when there is a risk of damage; in contrast, the "Dynamic Wind Monitoring" function allows selective weather protection. In the presence of strong winds, it only protects the shades that are actually at risk of damage according to a wind analysis. This means the slat tracking for glare-free operation and the automatic thermal control for reducing cooling loads can remain active for the remaining blinds, for example. That way, they can continue to maximize comfort and optimize energy efficiency and CO2 savings. Taking local wind profiles into account also provides better protection against damage.

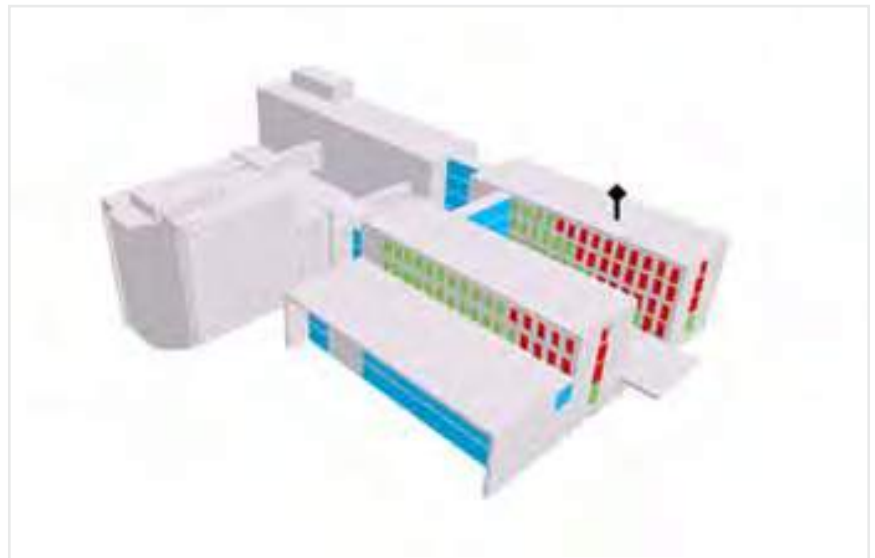

Item Description	
	Item No.
Application Weather Station, Dynamic Wind Protection; Single License; Online activation	2759-243/261-1000
Compatible Controllers	
Controller PFC200; G2; 2ETH RS	750-8212

A single license allows installation on one controller. One license per controller is required.

Delivery type	License certificate by email (software available for download)
For data sheet and additional information, see:	wago.com/2759-243/261-1000

The „Application Weather Station, Dynamic Wind Protection" software is a pre-programmed application based on the CODESYS Development Environment and can be used for PFC200 G2 Controllers.

To download the application and license to the device, WAGOupload software is required, which can be obtained free of charge from the WAGO homepage. Internet connection may be required for license activation.

WAGO Lighting Management Application

1

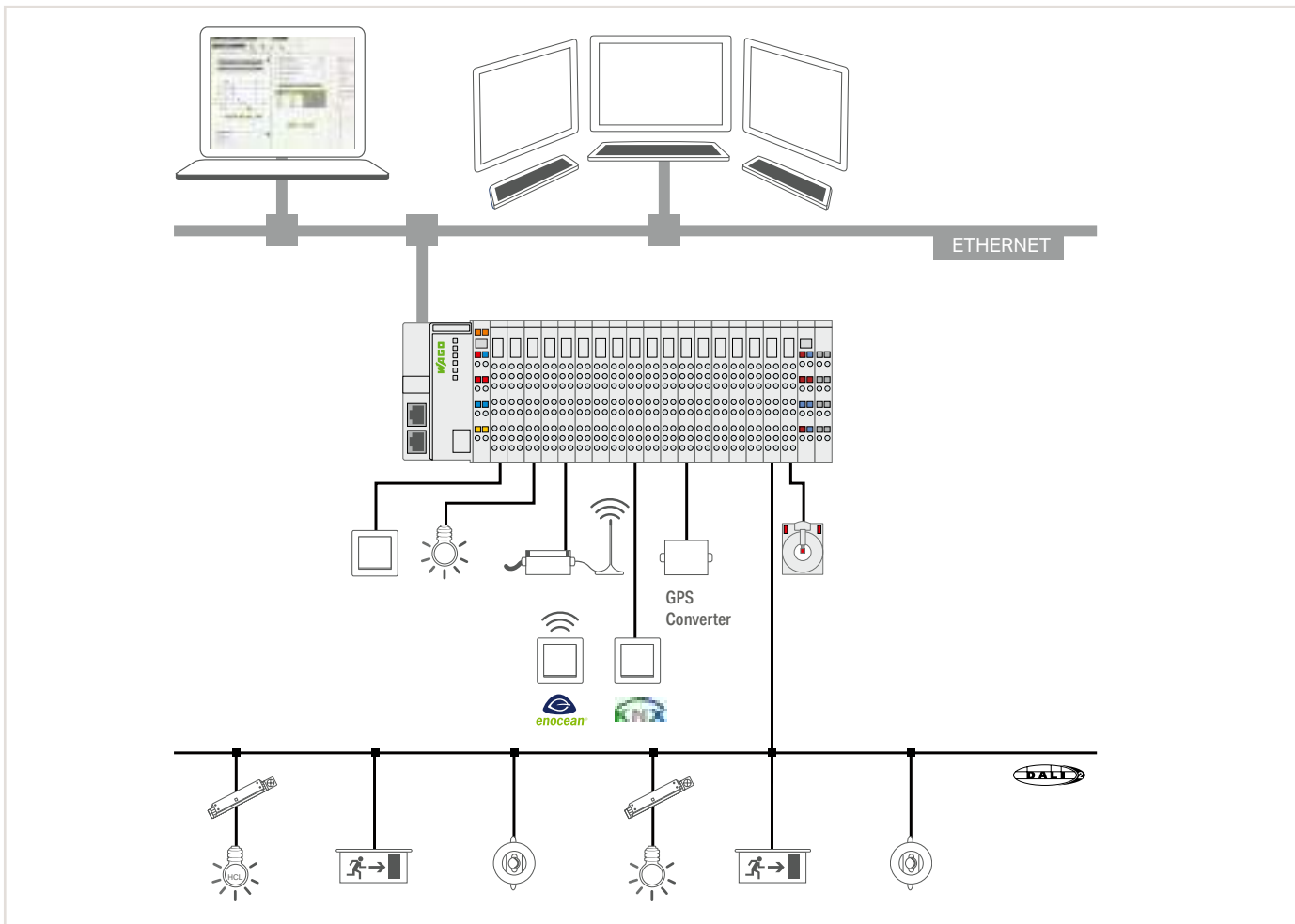

WAGO Lighting Management is a proven solution based on predefined hardware and preconfigured software, which greatly simplifies planning, commissioning and operation. The basic idea: WAGO Lighting Management is ready for the vastly different light requirements of warehouses and production facilities. For example, a production facility is divided into virtual rooms in which the light can be flexibly adapted. Each virtual room receives signals from sensors and actuators in order to automatically set the appropriate light intensity. Virtual rooms allow both conversions and remodeling to be implemented quickly and simply via Web configuration. A separate HTML5 user interface is available for convenient and intuitive operation of WAGO Lighting Management. Operation is optimized for display on different end devices, such as tablets, smartphones and touch panels.



Item Description		
		Item No.
Lighting Management Application; Single License; Online Activation		2759-204/261-1000
Lighting Management Visualization; Single License; Online Activation		
Visualization – S	1 controller	2759-2101/271-1000
Visualization – M	up to 3 controllers	2759-2102/271-1000
Visualization – L	up to 10 controllers	2759-2103/271-1000
Compatible Controllers/Touch Panels		
Controller PFC200; G2; 2ETH RS		750-8212
Touch Panel 600 Advanced Line; PIO3		762-53xx/8000-002

Delivery type	License certificate by email (software available for download)
Data sheet and additional information, see:	wago.com/2759-204/261-1000 wago.com/2759-210x/271-1000 wago.com/lighting-management

The "Lighting Management" software is a pre-programmed application based on the CODESYS Development Environment and can be used for both PFC200 G2 Controllers or Touch Panels 600.

To download the application and the license to the device, the WAGOupload software is required, which can be obtained free of charge from the WAGO homepage. Internet connection may be required for license activation.

A single license allows installation on one controller/touch panel. One license per controller/touch panel is required.

The products listed below are typically used in conjunction with the "Lighting Management" Application. Detailed information about the products, as well as other variants and accessories, can be found in our Full Line Catalog, Volume 3 or Volume 4.

Lighting Management Application		
Required Products	Description	Item No.
Base Unit		
DALI Multi-Master	In addition to 64 DALI actuators (ECGs), a DALI Multi-Master Module supports up to 16 DALI Multi-sensors (max. 64 sensor addresses); max. 10 DALI modules per base package.	753-647
End Module	An end module must be snapped onto the assembly at the end of a fieldbus node.	750-600
Power Supply to I/O Node	24 VDC power supply to controllers and additional modules	787-1012
Power Supply to DALI Multi-Master	Supplies a maximum of five DALI Multi-Master modules	787-1007
Extension for Inputs/Buttons		
16-Channel Digital Input; 24 VDC; 3 ms	For 1...16 light button/switch inputs; max. 4 extensions per base package	750-1405
Extension for Outputs/Actuators		
16-Channel Digital Output; 24 VDC; 0.5 A	For 1 ... 16 actuators/lamps/relays/ECG control; max. 2 extensions per base package	750-1504
Socket with Relay and Status Indicator; 1 Make Contact; 24 VDC	Light switching via relay	788-357
Extension for EnOcean Radio		
RS-232/-485 Serial Interface	Serial interface connects to STC65-RS-485 EVC EnOcean Radio Transmitter/Receiver (for 1 ... 64 rocker switches)	750-652
EnOcean Receiver/Transmitter	Receives EnOcean radio signals and transmits them to the I/O node	2852-7101
EnOcean Repeater	Extends the transmission range (for more planning information, visit the EnOcean website)	2852-7102
Radio Transmitter; EnOcean easyfit PTM 250; 2-Channel Lighting Control	1 ... 2 or 1 ... 4 signals; range of 30 meters from the radio receiver in buildings	758-940/001-000
Radio Transmitter; EnOcean easyfit PTM 250; 4-Channel Lighting Control		758-940/003-000
Extension for External Time Request		
GPS DCF Converter	Converter/external receiver for time synchronization	2852-7901
Extension for Energy Data Measurement		
3-Phase Power Measurement; 690 VAC	The 3-Phase Power Measurement Module (750-495) measures electrical data in a three-phase supply network.	750-495/xxx-xxx
Current and Voltage Connections	Pre-assembled terminal block assemblies for easy connection and short-circuiting of current transformers (for current transformers, see Full Line Catalog, Volume 4)	2007-8874; 2007-8877
Extension for KNX Buttons		
KNX/EIB/TP1 Interface	Connects KNX buttons to the I/O node; max. 1 module per base package	753-646
Extension for Sensors (DALI-2)		
DALI Sensor; PD11-BMS-FLAT	LOW BAY Sensor for offices (2 ... 5 m)	2852-7210
DALI Sensor; PD4-BMS-GH	HIGH BAY Sensor for warehouses (5 ... 16 m)	2852-7213
DALI Sensor; PD4N-BMS	MID BAY Sensor for open-plan offices, underground garages, entrance halls, production facilities (2 ... 10 m)	2852-7214
Adapter; AP Assembly Kit IP54; Accessories for 2852-7214	Accessories for surface mounting of the PD4N-BMS (B.E.G.)	2852-7215
DALI Sensor; MSensor G3 SRC 30 PIR 5DPI WH	LOW BAY Sensor for offices (up to 5 m)	2852-7220
DALI Sensor; MSensor G3 SSM 30 10DPI WH	MID BAY Sensor for high-ceiling rooms (up to 10 m)	2852-7221
DALI Sensor; IR Quattro HD DALI-2	LOW/MID BAY Sensor for offices (2.5 ... 10 m)	2852-7230
DALI Sensor; IR Quattro SLIM XS DALI-2	LOW BAY Sensor for offices, slim design (2.5 ... 4 m)	2852-7231
DALI Sensor; IS3360 MX HIGH BAY DALI-2	HIGH BAY Sensor for industrial buildings, circular detection range (4 ... 14 m)	2852-7232
DALI Sensor; IS345 MX HIGH BAY DALI-2	HIGH BAY Sensor for industrial buildings, rectangular detection range (4 ... 14 m)	2852-7233
DALI XC G3 (DALI-2)	Push-button coupler connects 4 conventional push-buttons to DALI	2852-7225
DALI Sensors		
DALI Multi-Sensor Kit	Brightness measurement and motion sensor: Kit connects to a DALI bus system	2851-8201
DALI Sensor Coupler	Sensor coupler connects MULTI-3-CI Sensors to DALI (max. 16 DALI Sensor Couplers per 753-647 DALI Multi-Master)	2851-8202
DALI HIGHBAY ADAPTER + HIGH BAY	Brightness measurement and motion sensor for large installation heights (3 ... 13 m)	2852-7207, 2852-7201
DALI HIGHBAY ADAPTER + VISION	Motion sensor for large areas, open offices, hallways or warehouses	2852-7207, 2852-7202
DALI LS/PD LI	Motion sensor for office lighting (1 ... 5 m)	2852-7203
DALI Sensor Coupler HF LS LI +	Light and recessed ceiling sensor: combined daylight and motion detection, motion detection via radar	2852-7205
Radar Sensor HF LS LI		2852-7206
4p4c Connection Cable, 50 cm		2852-7208
DALI XC	Push-button coupler connects 4 conventional push-buttons to DALI	2852-7301
DALI Sensor Coupler E	Sensor coupler connects standard sensors to DALI	2852-7204

WAGO Application Grid Gateway



Setting application parameters via HTML-5 WEB visualization



Example: Grid Gateway Distribution Box

WAGO Grid Gateway Application supports power distribution grid operators in assessing the grid performance. This application allows grid operators to use their existing distribution grid more efficiently, while avoiding unnecessary grid expansion. The measurement technology required in the substation for both the transformer and low-voltage outputs can be easily retrofitted.

The measurement values of the medium voltage, transformer, low-voltage outputs, valve positions and temperatures are transmitted to the grid control system via IEC 60870-5-104. Commands and setpoints can also be received and processed. External measurement systems such as short-circuit/ground-fault direction indicators can be easily parametrized via Modbus RTU. The entire parameterization can be stored in a clear manner and, if necessary, added to other stations. The option of simulating measured data makes it possible to commission new substations at the station builder's location from the grid control system without the field side being connected.

All data, for example the measured values from the low-voltage outputs, can be communicated via MQTT to a cloud.

Asset managers can more accurately plan substation maintenance cycles by accessing both stored data and digital drag indicators. Grid managers are prepared for local situations, having remote access for maintenance and errors in the grid.

Remote updates for software modules and extensions are possible, eliminating unnecessary in-the-field service.

Upon request, WAGO will provide you a hardware solution tailored to your customers' substations.

Patch and device management is available for the administration of a large number of distributed telecontrol devices with the WAGO Application Grid Gateway. This enables application updates, configuration changes, security patches and firmware upgrades, among other things.

Item Description	
	Item No.
Application Grid Gateway; Single License; Online activation	2759-2015/261-1000
Application Grid Gateway; Single License	2759-2015/260-1000
Accessories	
Custom/tailored system distribution boxes (e.g., for use in substations) are available	upon request
Compatible devices	
PFC200; G2; 4ETH	750-8210
PFC200; G2; 4ETH; T	750-8210/025-000
PFC200; G2; 4ETH; XTR	750-8210/040-000
PFC200; G2; 2ETH 2SFP	750-8211
PFC200; G2; 2ETH 2SFP; XTR	750-8211/040-000
PFC200; G2; 2ETH RS	750-8212
PFC200; G2; 2ETH RS; TELE; T	750-8212/025-001
PFC200; G2; 2ETH RS; TELE; T; ECO	750-8212/025-002
PFC200; G2; 2ETH RS; XTR	750-8212/040-000
PFC200; G2; 2ETH RS; Tele; XTR	750-8212/040-001
PFC200; G2; 2ETH M12; RS; XTR	750-8212/040-010
PFC200; G2; 2ETH RS; 4G	750-8217
PFC200; G2; 2ETH RS; 4G; T	750-8217/025-000

Technical Data	
Number of LV outputs	Up to 17 LV outputs
Firmware	Hardening in compliance with BDEW White Paper
Patch/device management	Application updates, configuration changes, security patches and firmware upgrades
Communication to the grid control system	IEC 60870-5-104
Communication to the office network	HTTPS, MQTT
Memory required on the SD card	Less than 2 MB measurement data per day for 15 LV outputs
Authentication	Local, LDAP
User groups	Grid manager, grid technician, grid planner, asset manager, administrator
Network interfaces	Secure separation between SCADA and office networks
Delivery type	License certificate by email (software available for download)
Data sheet and additional information, see:	wago.com/2759-2015/261-1000

A single license allows installation on one controller. One license per controller is required.

WAGO Application Medium Voltage Calculation

Add-on Application for WAGO Application Grid Gateway



Setting the individual transformer values



View of the current measured values and the calculated medium voltage values

It is becoming increasingly important for network operators to precisely monitor the medium-voltage values in transformer stations. For example, these values are required for calibrating the short-circuit/ground-fault indicators and are essential for wide-range control.

Until now, accurate medium-voltage measurement has required expensive resistive couplers or ohmic medium-voltage sensors.

With the WAGO Application Medium Voltage Calculation (additional application), highly precise medium voltage values can be calculated without resistive couplers based on precisely measured low voltages. Through this, an accuracy class of 1.5 percent is achieved.

The add-on application for medium-voltage calculation runs on a Docker® container. Data exchange between the "WAGO Application Grid Gateway" basic application and the container occurs via the Modbus TCP protocol. The necessary transformer parameters can be conveniently entered via the Web

visualization or CSV file upload. Electrical variables are measured on the low-voltage side either with WAGO's 3-Phase Power Measurement Modules (Item No. 750-495/040-010) or third-party devices that transmit their values via the Modbus® protocol, for example.

The mean voltage is calculated by accounting for various parameters such as winding ratios, loads and temperatures. The calculation also incorporates individual transformer parameters, such as the short-circuit voltage, no-load losses or the losses in the event of a short circuit.

The higher-level WAGO Application Grid Gateway transmits the calculated, measured values to the process control systems or the grid operators' data clouds, for example.

Item Description	
WAGO Application Medium Voltage	Item No.
Single license	2759-2016/261-1000
Requirement	
WAGO Application Grid Gateway	2759-2015/26x-1000
Compatible Devices	
PFC200; G2; 4ETH	750-8210
PFC200; G2; 4ETH; T	750-8210/025-000
PFC200; G2; 4ETH; XTR	750-8210/040-000
PFC200; G2; 2ETH 2SFP	750-8211
PFC200; G2; 2ETH 2SFP; XTR	750-8211/040-000
PFC200; G2; 2ETH RS	750-8212
PFC200; G2; 2ETH RS; TELE; T	750-8212/025-001
PFC200; G2; 2ETH RS; TELE; T; ECO	750-8212/025-002
PFC200; G2; 2ETH RS; XTR	750-8212/040-000
PFC200; G2; 2ETH RS; Tele; XTR	750-8212/040-001
PFC200; G2; 2ETH M12; RS; XTR	750-8212/040-010
PFC200; G2; 2ETH RS; 4G	750-8217
PFC200; G2; 2ETH RS; 4G; T	750-8217/025-000

Technical Data

Accuracy class of up to 1.5 percent, depending on the available transformer parameters

Delivery type

License certificate by email (software available for download)

A single license allows installation on one controller. One license per controller is required.

WAGO Application Customer Substation



WAGO Application Customer Substation allows customer systems to communicate with the regional grid operator (control technology) in compliance with the IEC 60870-5-101 or IEC 60870-5-104 guidelines. Measured values like voltage, reactive power, active power and station parameters (position messages) are determined and monitored. The application enables automatic mapping of the respective data points according to the TAB (Technische Anschlussbedingung) technical connection requirement (TCR) of the selected grid operator.

The station can be customized depending on the number of sections. The application connects all relevant measurement and protection systems. For standard devices, communication templates are stored for easy configuration.

Optionally, data can also be transmitted to a cloud (MQTT).

A direct marketer interface is also available.

Available options:

A certified EZA controller (Item No. 2759-203/211-1000) can be activated and connected to various actuators if desired.

The WagoAppRTU_Slaves library on which the application is based provides simple function blocks for use with specific power system operators. They enable customer systems to communicate with the grid operator per IEC 60870-5-101 or IEC 60870-5-104.

Supported grid operators: E.ON (Avacon Netz, Bayernwerk Netz, Schleswig Holstein Netz, E.DIS Netz); EWE NETZ; Netze BW; Westnetz, VSE; WEMAG; Mitnetz and SachsenNetze. Note: Additional information available upon request

Item Description	
WAGO Application Customer Substation	Item No.
Single license; online activation	2759-2018/261-1000
WAGO Cloud	
WAGO Cloud; 100 license points	2759-1061/651-010
WAGO Cloud; 500 license points	2759-1061/651-050
WAGO Cloud; 1000 license points	2759-1061/651-100
Compatible Devices	
PFC200; G2; 4ETH	750-8210
PFC200; G2; 4ETH; T	750-8210/025-000
PFC200; G2; 4ETH; XTR	750-8210/040-000
PFC200; G2; 2ETH 2SFP	750-8211
PFC200; G2; 2ETH 2SFP; XTR	750-8211/040-000
PFC200; G2; 2ETH RS	750-8212
PFC200; G2; 2ETH RS; TELE; T	750-8212/025-001
PFC200; G2; 2ETH RS; TELE; T; ECO	750-8212/025-002
PFC200; G2; 2ETH RS; XTR	750-8212/040-000
PFC200; G2; 2ETH RS; Tele; XTR	750-8212/040-001
PFC200; G2; 2ETH M12; RS; XTR	750-8212/040-010
PFC200; G2; 2ETH RS; 4G	750-8217
PFC200; G2; 2ETH RS; 4G; T	750-8217/025-000

Functions	
Control sections	Input panel (1-n) Transfer panel/network connection point Metering panel Disconnectors, HH fuses Generation plants (various energy types) Additional generation units
Delivery type	License certificate by email (software available for download)
For data sheet and additional information, see:	wago.com/2759-2018/261-1000

A single license allows installation on one controller.
One license per controller is required.

Complete Solutions	Item No.
Control cabinet customer substation – standard Design according to the TCR of the grid territories of E.ON and grid subsidiaries (AVACON, E.DIS, SH Netz, Bayernwerk), Westnetz, Wemag Netz, NetzeBW, EWE	8007-100/1000-247
Control cabinet customer substation – comb., including protection Design according to the TCR of the grid territories of E.ON and grid subsidiaries (AVACON, E.DIS, SH Netz, Bayernwerk), Westnetz, Wemag Netz, NetzeBW, EWE Includes protective devices: - SEG MRA4; - NA-protection Ziehl UFR1001E Note: Other protective devices upon request!	8007-100/1000-270

WAGO Power Plant Control Library

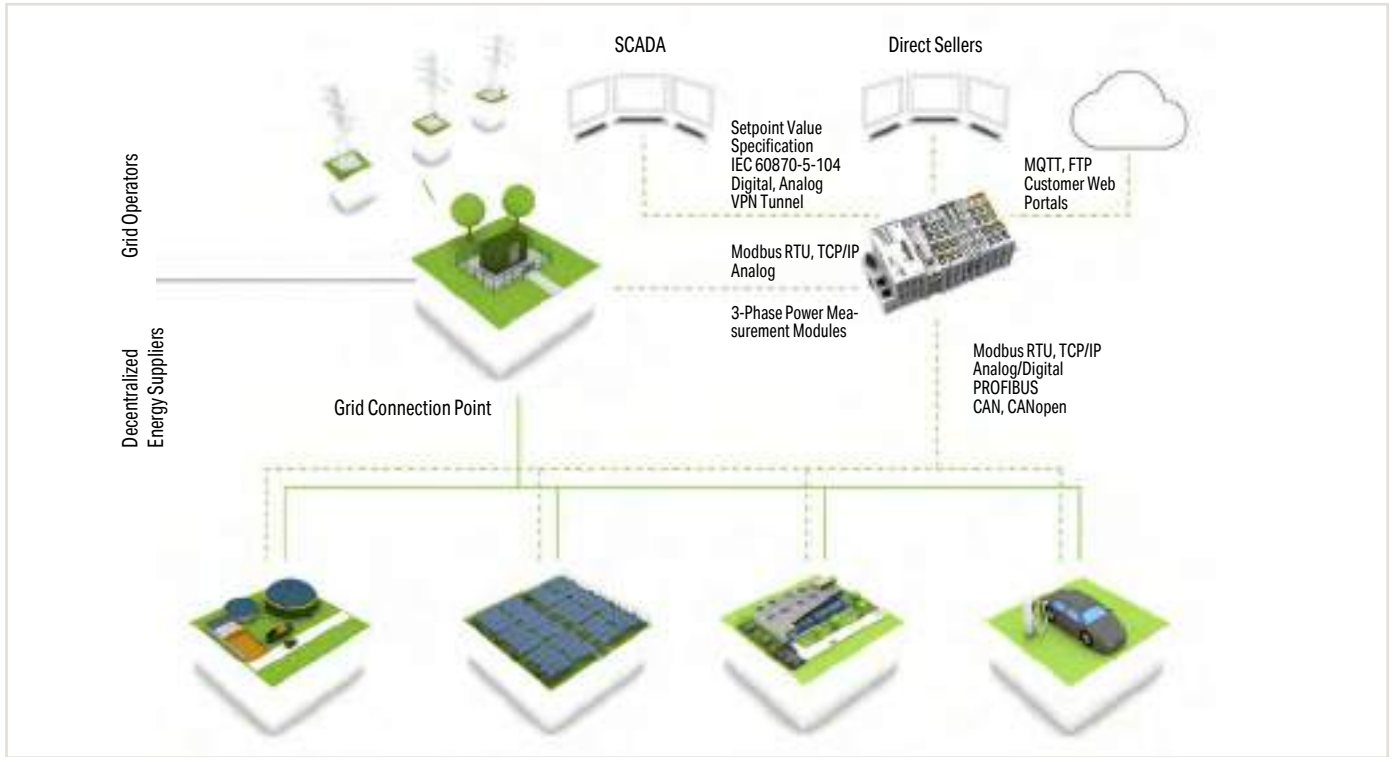

The WAGO Power Plant Control Library is an CODESYS library with a control algorithm for the active and/or reactive power in energy generation plants.

The control algorithm for active and/or reactive power and corresponding setpoint specifications required by the operator can be adjusted during operation per IEC 60870 by, e.g., telecontrol technology. The controller compares the specified setpoint values with the actual values measured at the network connection point and provides the calculated correction variables for the energy generation plant.

This library can be used on second-generation PFC200 Controllers and is certified per VDE-AR-N 4110 or 4120.

The library can be used for a 30 day trial period at no cost, after which a license for the respective controller is required.

The license can be separately purchased under Item Number 2759-203/211-1000.

Functions:

- Pfix, Qfix: Fixed active/reactive power specifications
- P(f): Frequency-dependent active power regulation
- P(Uoff): Active power ramp – restart after network failure
- Q(P): Reactive power control per active power characteristic
- Q(U): Reactive power control per voltage characteristic
- Q(Udb): Reactive power control per voltage characteristic with voltage limiting function
- cosφfix: Fixed displacement factor specification
- PSM, QSM: Slave mode, looping through the external active/reactive power specifications

Item Description	
WAGO Power Plant Control Library	Item No.
Single License; Online Activation	2759-203/211-1000
Compatible Controllers	
Controller PFC200; G2; 2ETH RS; Tele; T	750-8212/025-001
Controller PFC200; G2; 2ETH RS; Tele; T; ECO	750-8212/025-002
Controller PFC200; G2; 2ETH RS CAN DPS; Tele; T	750-8216/025-001

Certification	VDE-AR-N 4110 / 4120
Delivery type	License certificate per email
Data sheet and additional information, see:	wago.com/2759-203/211-1000

Internet connection may be required for license activation.

A single license allows installation on one controller. One license per controller is required.

Controller Redundancy Master Library

Description:

Increase availability in central ship alarm systems with WAGO's Application-Based Controller Redundancy (ACR). The licensed software library (2759-245/211-1000) and an CODESYS redundancy framework allows you to easily program and operate redundant master PLCs in single point of failure (SPOF) tolerant systems. A large number of the available 750 Series I/O Modules can be integrated into the system via Smart Couplers. These decentralized PLCs automatically recognize the input and output modules, which makes commissioning easy. The redundant communication of the two Master PLCs and the Smart Couplers is performed either via two separate networks (Dual-LAN) or a ring topology. These Master PLCs (2nd generation PFC200) communicates with higher-level SCADA systems, for example, via the Modbus TCP protocol. The application notes (a2020003 and a2020004) describe the practical use of the library and define the application area and the maximum number of participants within the system.

Advantages:

- Easy commissioning of the entire system with WAGO's standard hardware
- Simple/slow control loops can be mapped (Alarm & Monitoring, Data Acquisition, Slow Running Processes)
- Low switchover time (per marine classification society requirements)
- Use of complex modules such as HART or DALI

Benefits:

- With the application redundancy concept, WAGO provides you with a redundant framework for simple and economical system integration in ship technology.
- You save engineering effort and can focus on your application.

Licensing:

To use the "WagoAppRedundancyMaster.library," a "Controller Redundancy Master Library" license (2759-245/211-1000) must be purchased for each Master PLC. An SD card image in the redundancy framework is available for the Smart Couplers.

Use:

The license is registered with WAGO Upload and loaded onto a device. No other installation steps are required.

Note:

Register here to download the redundancy framework and test ACR free of charge for 30 days.

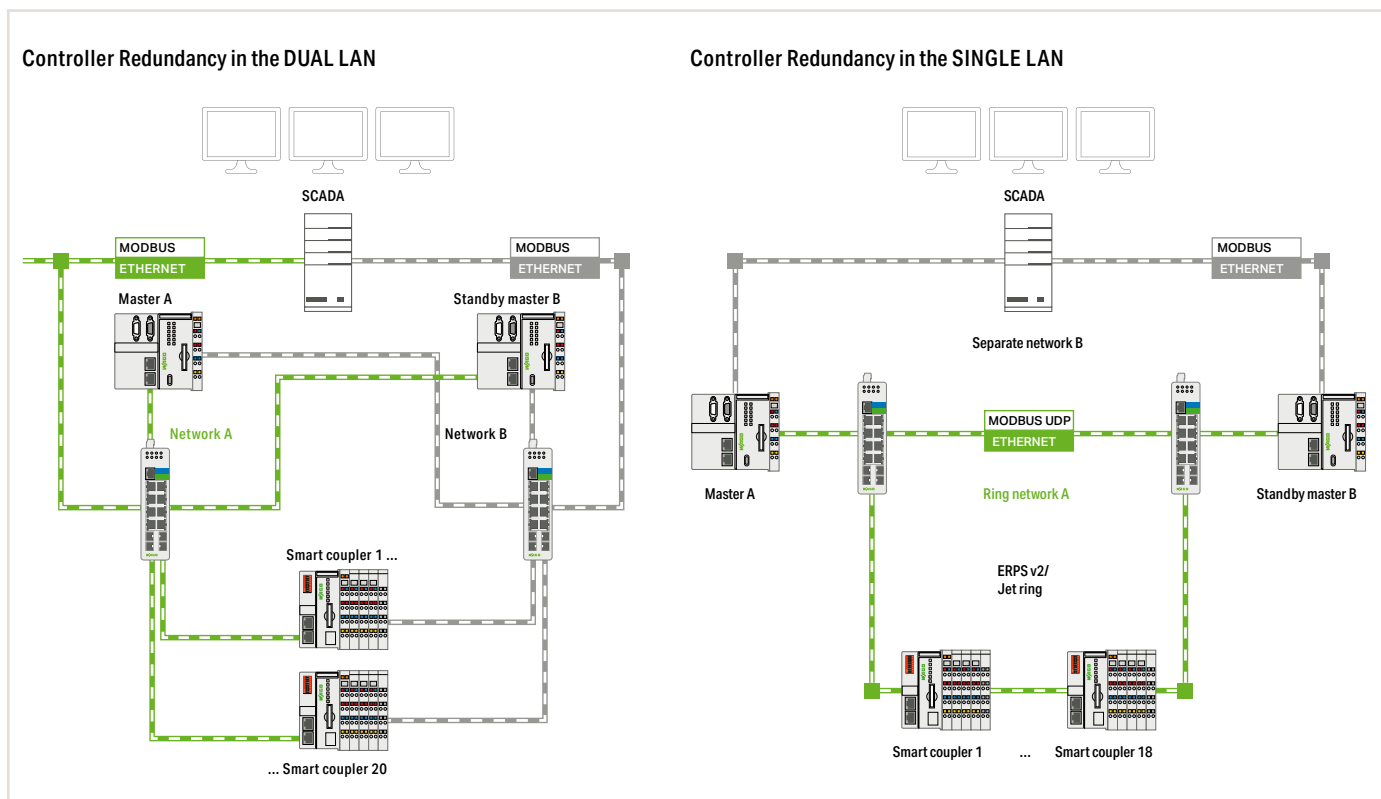

Item Description	
Controller Redundancy Master Library	Item No.
Single License; Online Activation	2759-245/211-1000
Recommended Controller	
PFC200; G2; 2ETH RS	750-8212

Delivery type	License certificate by email (software available for download)
Data sheet and additional information, see:	wago.com/2759-245/211-1000

Internet connection may be required for license activation. A single license allows installation on one computer.

WAGO Gateway Application

With the new WAGO Gateway Application, it is possible to implement information exchange between different bus systems. This is supported by a user-friendly interface, so no programming is necessary – nothing but configuring connections.



Function in Detail:

- Automatic detection of station structure
- Display of the available interfaces
- Creation of data points
- Import/export of ETS files (KNX)
- Linking of data points
- Conditional reading/writing

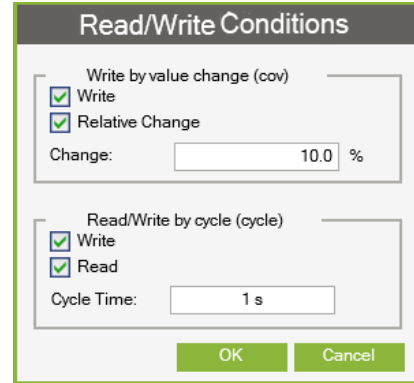

Benefits:

- Exchange of information between the bus systems:
 - Modbus TCP
 - Modbus UDP
 - Modbus RTU
 - KNX
- Commissioning time reduced through interface-supported configuration instead of programming
- Easily manage up to 255 KNX data points per KNX module via ETS import and export

- Functional coupling

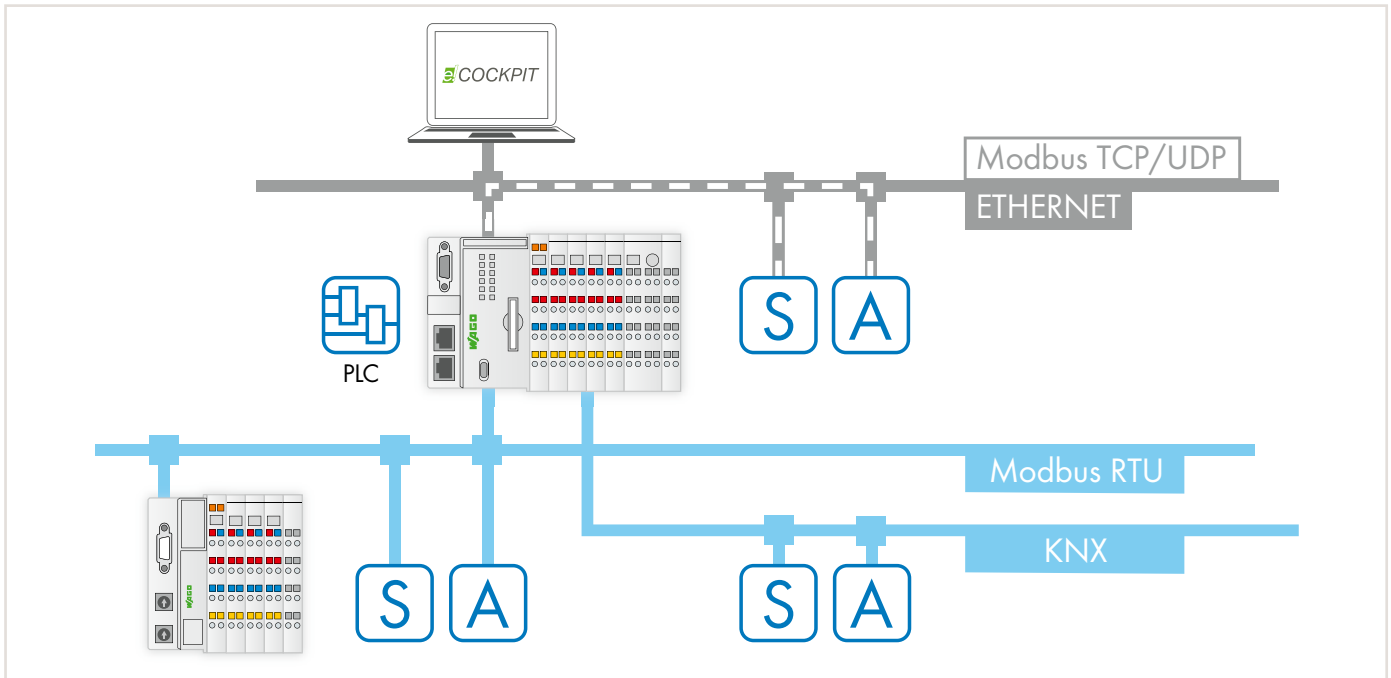

Item Description	
WAGO Gateway Application	Item No. Download

Delivery type	Closed application Download at www.wago.com
Compatible Controller	750-8212
PFC200; G2; 2ETH RS	

You can find detailed information on the controllers in Section Controller PFC200.



Software

Engineering Software

- PC and web-based software
- Customized tools for every automation task

Runtime Software

- Standard machine component
- Comprehensive, tested software modules for control, regulation, operation and monitoring

Mobile Software (Apps)

- Machine operation and monitoring via tablet and smartphone

Solutions

- Cloud solutions
- Reusable, customizable software applications

Software

Engineering Software, Runtime Software and Mobile Software



	Page
General Product Information	30

	Description	Item No.	
Engineering Software			
Designing and marking	smartDATA Engineering	Online	
Programming and configuration software	CODESYS V3	Download	32
	Solution Builder	Download	34
	WAGO-I/O-PRO	759-333	36
	WAGO-I/O-CHECK	759-302	37
	IO-Link Configurator	2759-106/1121-1000	38
	SMI Configurator	Download	39
	BACnet Configurator	Download	40
	DALI Configurator	Download	41
	LON® configurator	Download	42
Plug-ins	Device- and Industry-Specific Configurators		
	WAGO ETS Plug-in	Download	43

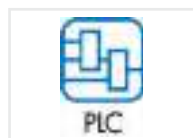

	Description	Item No.	
Runtime Software			
Libraries	based on CODESYS V3	Download	44
	WAGO-I/O-PRO (based on CODESYS V2.3)	Download	45
Runtime	Multi Cloud Connectivity	2759-248/211-1000	48
	Sparkplug	2759-247/211-1000	49
	MicroBrowser	2759-230/211-1000	50
	BACnet/IP	2759-283/211-1000, 2759-286/211-1000 2759-2273/211-1000, 2759-2276/211-1000	51
	OPC UA Server Extended	2759-2233/211-1000, 2759-2236/211-1000	52
	OPC UA Mapping Editor	Download	53
	OPC UA Client	2759-2230/211-1000	54
	IEC-60870 Slave	2759-290/211-1000	56
	IEC-60870 Master	2759-293/211-1000, 2759-296/211-1000	57
	IEC-61850 Client	2759-2243/211-1000, 2759-2246/211-1000	58
	IEC-61850 Server	2759-2240/211-1000	59
	DNP3 Slave	2759-2290/211-1000	60
	DNP3 Master	2759-2293/211-1000, 2759-2296/211-1000	61



	Description	Item No.	
Mobile Software (Apps)			
	WAGO WebVisu App	Download	62
	WAGO I/O Field App	Download	63



	Description	Item No.	
Accessories			
	Configuration Cable, USB Communication Cable		64

Software

General Product Information

Software Factors into Success

Projects in production, process and building automation are characterized by shorter and shorter implementation times, ever more complex structures and the increasing role of software as part of the overall solution. In fact, software is becoming an essential factor that influences the success of a project.

Engineering software is used for both machine and system development, as well as the implementation of building automation projects. Runtime software controls the devices during operation.

Customized Software Tools

Significant challenges must be overcome to develop, operate and maintain modern machines and systems, as well as program, configure and commission building automation applications. Customized software tools are available as needed for every task. With these, specialized automation tools for specific user groups are now available, giving users exactly the features they need for their applications. Wherever possible and appropriate, standards are used in engineering, such as CODESYS V3. Thus the automation environment is becoming more and more open.

CODESYS as an Integrated Environment



CODESYS

All WAGO Controllers are equipped with the high-performing CODESYS industry-standard development environment. This enables software development in both IEC 61131-3 PLC programming languages (ST, FBD, LD, IL, SFC) and CFC. As a trusted programming environment, CODESYS guides developers, enabling them to reuse and further develop existing projects without relearning software. This means that advanced paradigms, such as object-oriented programming (OOP), or modern visualization technologies, are available.

Pre-Made Software Solutions

Pre-made software solutions and applications simplify automation. Such solutions involve reusable software that can be used for a specific application by making simple adjustments. This approach saves time and money. WAGO's pre-made software solutions can be found in Section 1.

Open to Proven Standards



WAGO Software is open to well-established standards and supports all prominent fieldbuses, making it an investment in the future. This allows all of WAGO's components to be seamlessly integrated into engineering software via standardized device description files. Furthermore, connecting controllers to fieldbus systems via WAGO Engineering Software is incredibly simple, opening up all the advantages of existing field devices. Ultimately, WAGO Software is based on modern IT standards and development methods for long-term viability.

Extensive Import and Export Functionality



WAGO's software tools demonstrate an impressive ability to exchange project data with the external software tools involved in the development process – preventing costly, error-prone double entry.

Industry-Specific Configurators



Whether industry, process or building automation, every sector and industry has specific requirements. Therefore, plug-ins specifically customized for the needs of individual industries are available in addition to WAGO's software portfolio. For example, these plug-ins can be used to measure energy or easily configure a DALI network.

Your Benefits:

- Customized software for every automation task
- Extensive import functions from external design tools
- Plug-ins for industry-specific development environments
- Comprehensive software solutions for various industries
- Simple and secure licensing

Software

General Product Information

Software for Mechanical Engineering
 WAGO Software is used in every phase of machine and system automation – from design to successful machine operation.

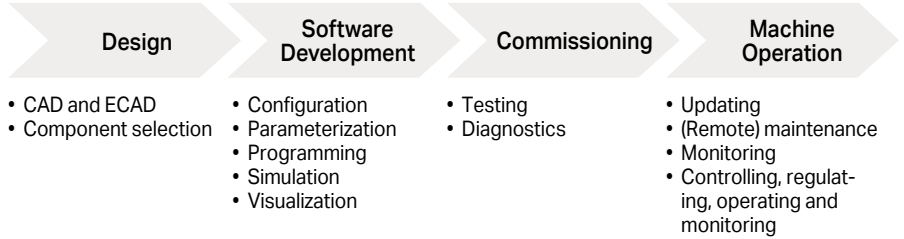

Engineering Software
 Quickly implementing complex machine functions is critical in modern mechanical engineering applications. WAGO's PC-based engineering software supports all development activities. The focus is on simple configuration, timely programming and efficient commissioning of automation network components.

Engineering tools are typically not permanently linked to the machine – they only communicate with the machine during startup and maintenance.

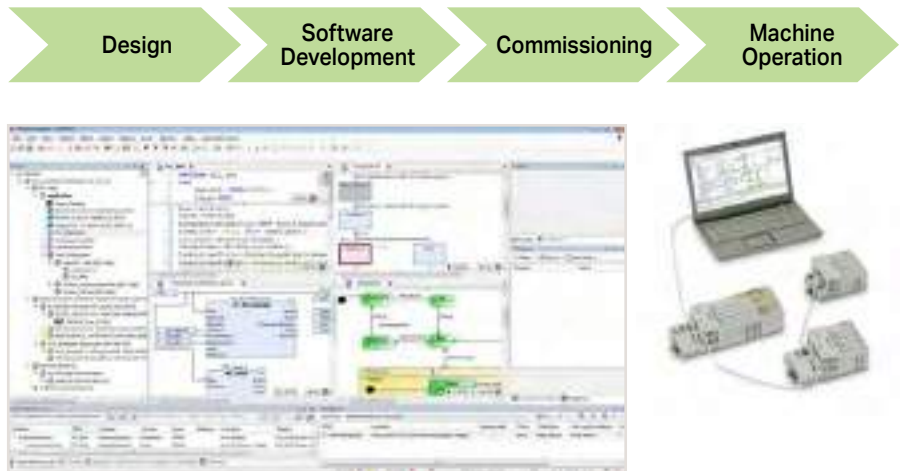

Runtime Software
 Machines are controlled by runtime software that determines behavior, while enabling both operation and current status monitoring for the user. It also transmits operating data to higher-level systems. With comprehensive, tried-and-tested software function blocks (IEC libraries), development goals are reached more quickly.

Unlike engineering software, runtime software operates continuously – it is a part of the machine and ensures correct operation.

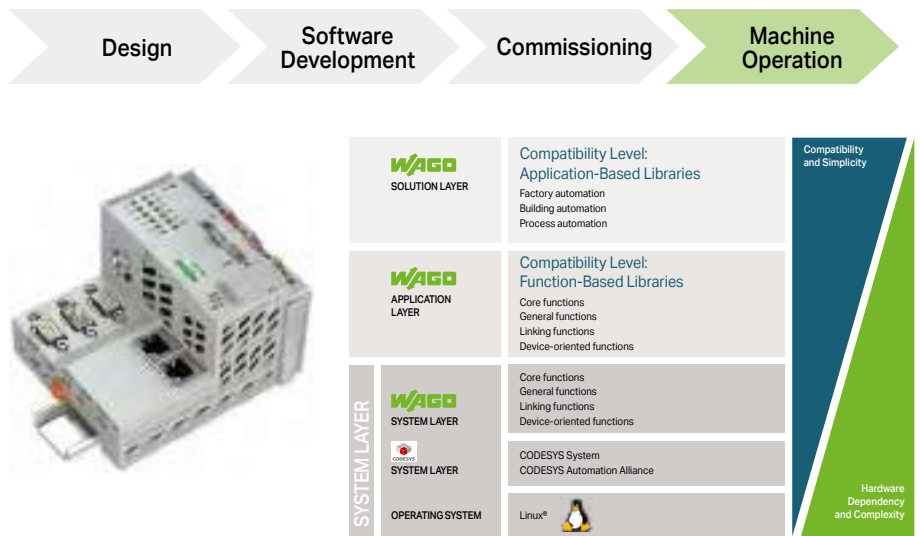

Mobile Software (Apps)
 Software on mobile devices offers productivity advantages in an industrial environment as well. This integration enables users to quickly and easily operate and monitor automation processes via smartphone or tablet – from virtually anywhere.

Mobile software typically communicates only with the machine's controller for a specific application.



2

CODESYS V3

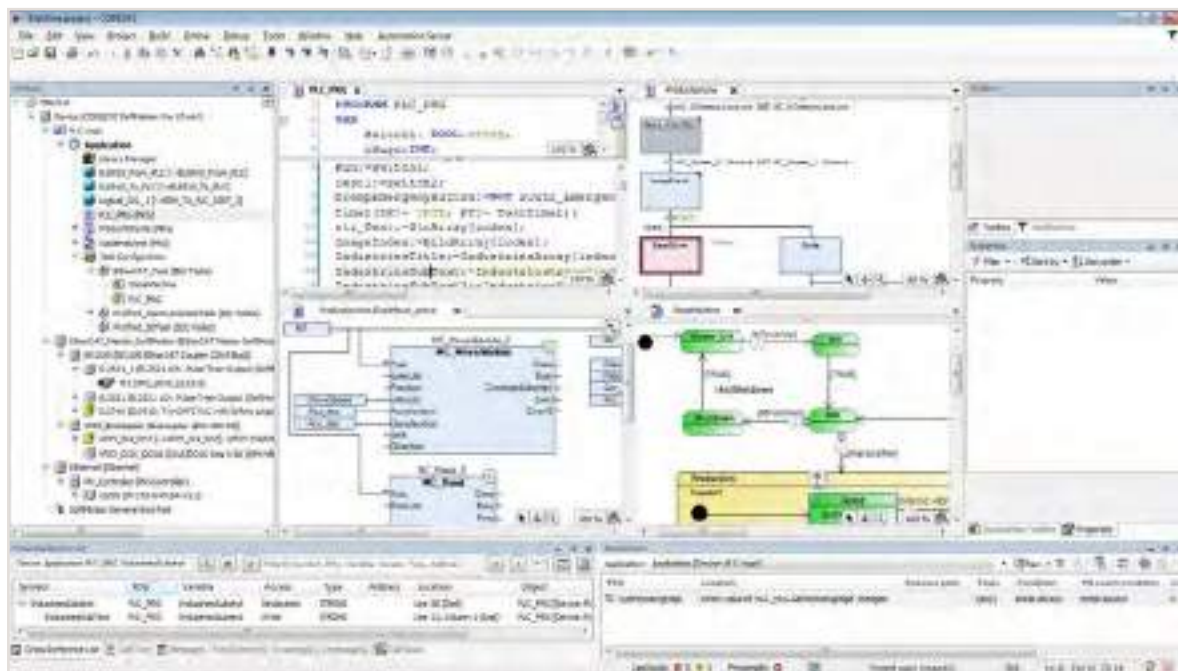

The CODESYS open automation software opens up flexible engineering possibilities based on an open industry standard that many different manufacturers use.

It offers a wide variety of integrated connectivity options, such as conventional fieldbuses, but also modern communication standards like OPC UA.

From controller configuration to programming, visualization and diagnostics, all functions are combined in one tool.

The basic programming environment is available for free and includes multiple built-in functions. WAGO also offers add-ons and an extensive collection of libraries, which are partly subject to a fee.

CODESYS users also benefit from the CODESYS community's broad-base expertise.

CODESYS V3

Via WAGO Download Center (Link: <https://downloadcenter.wago.com/>)

Supported operating systems	Windows 10 (64-bit); Windows 11 (64-bit)
System Requirements	
Processor	2.5 GHz
Memory	8 GB RAM
Hard disk space	12 GB
Supported devices	WAGO PFC200 G2; WAGO Edge Controller; WAGO Touch Panel 600 (Control Panel); WAGO Compact Controller; WAGO Basic Controller
Supported fieldbuses (depending on the devices and the respective firmware version)	CANopen; Modbus TCP/UDP; Modbus RTU; EtherCAT® Master; EtherNet/IP™ Scanner/Adapter; PROFIBUS® Slave; PROFINET Device
Paid options	BACnet® (see page 51) Telecontrol (see pages 56 ... 61)
More information about CODESYS:	https://store.codesys.com/codesys.html

Windows® is a registered trademark of Microsoft Corporation.

WAGO Navigator and Download Center

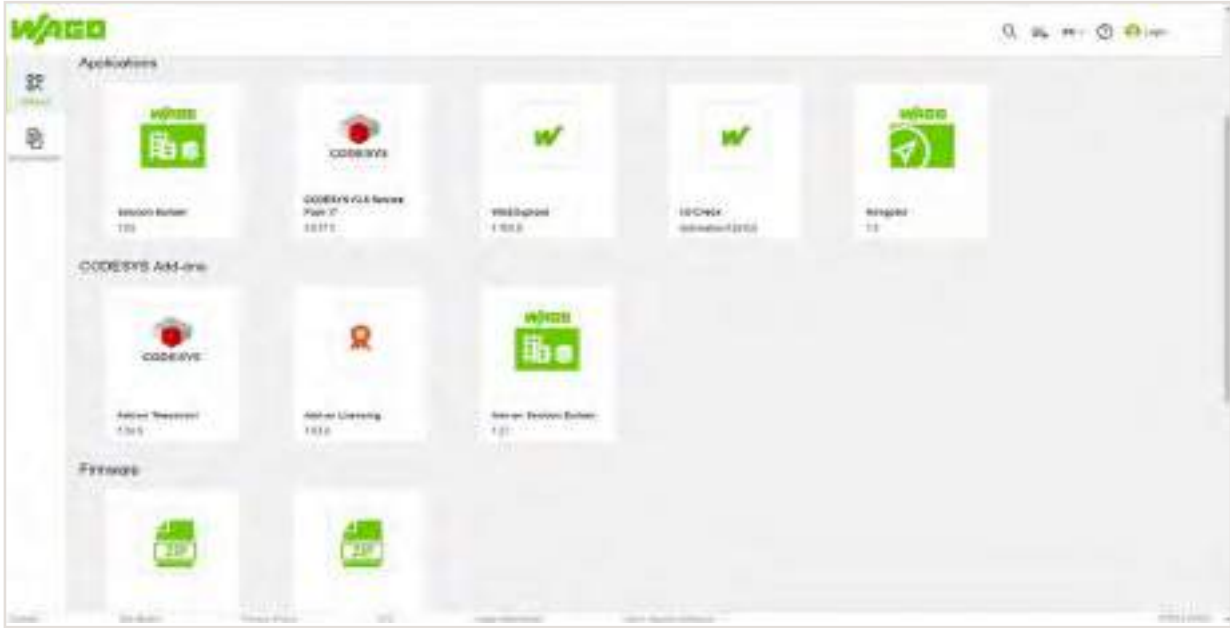

2

Always using the latest software version is very important, especially for cybersecurity. That goes without saying for a PC's operating system, but it's increasingly important within automation too.

To ensure no update is missed, the Download Center provides central access to all updates, for example, for the two engineering tools WAGO Solution Builder and CODESYS V3, along with libraries, firmware, etc.

In addition, the Navigator enables central notification of new WAGO software product versions.

After installation, the Navigator is fully integrated into Windows messaging. This means that the user no longer misses updates. A direct interface to the Download Center makes the update process particularly easy – with just a mouse click!

WAGO Navigator and Download Center
<https://downloadcenter.wago.com>

Supported browsers	Google Chrome; Microsoft Edge; Mozilla Firefox
Navigator supply channel	Via WAGO Download Center
Supported operating systems	Windows 10 (64-bit), Version 1809; Windows 11
System Requirements	
Hard disk space	120 MB (+210 MB for .NET 6 Runtime)

Windows® is a registered trademark of Microsoft Corporation.

WAGO Solution Builder

Efficient Engineering of Multi-Controller Projects

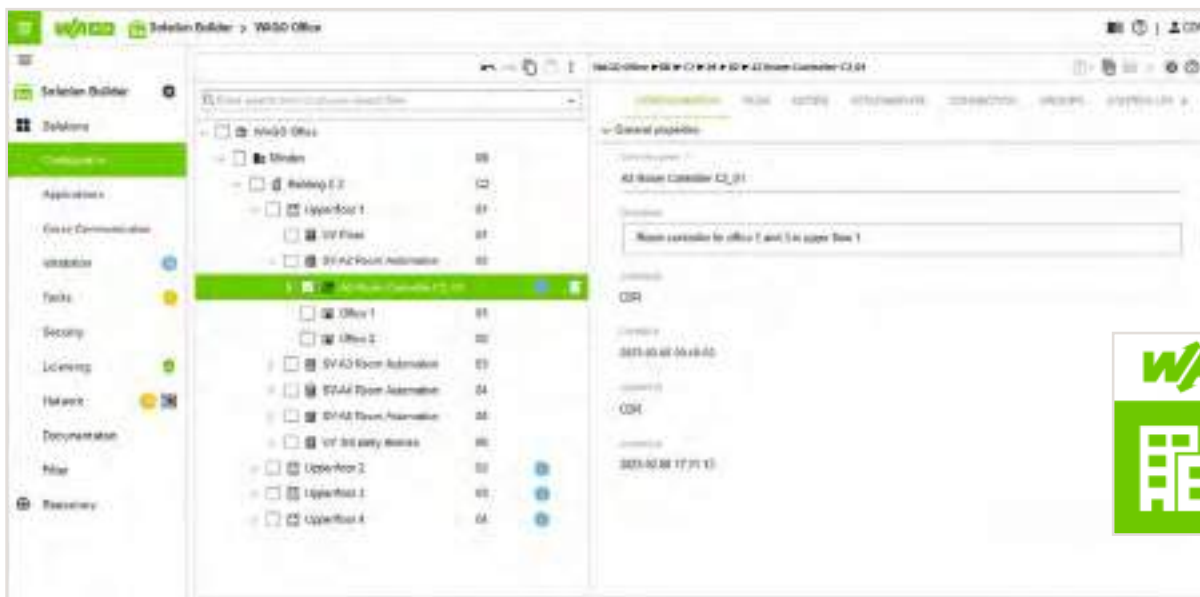

WAGO Solution Builder is an integrated and efficient software solution that optimally supports designers with hundreds of devices – especially in building automation.

The workflow is streamlined to separate full project creation in the office (offline) and commissioning on-site (online). All the project documentation can be generated with one mouse click. Applications can also be saved as templates for reuse. All user groups work together through the new software solution's central Web-based interface. This ensures a consistent workflow and lets you keep an eye on the whole building project.

The option of bulk data processing, even for projects with several controllers, also saves time and money.

The solution provides native support for customizable addressing systems for the project tree and the description of data points, so they are a fixed component of the project organization. That eliminates the need to create them later, which would take more time and money and be prone to errors.

Benefits at a glance:

- A clearly organized representation of the system on a Web interface
- An efficient workflow to save engineering time
- Intelligent bulk processing of data and devices helps prevent errors
- Comprehensive project documentation with one mouse click
- Efficient organization of (large) projects into solutions
- Working on a project in parallel
- Easy data transfer between employees
- Device management for many controllers, even for maintenance and service
- Complete controller commissioning workflow
- Configure applications without a programming background (IEC know-how) and transfer them to the device
- Easy basic cybersecurity protection for the controllers

WAGO Solution Builder			
Order Text	License Type	Description	Item No.
WAGO Solution Builder; User License; 1 year	Single license	Allows use on one PC by one user with any number of solutions (projects).	2759-132/1119-1012
WAGO Solution Builder; Site License; 1 year	Site license	Allows use on one server by any number of users, limited to one solution.	2759-132/1119-3012
WAGO Solution Builder; Server License; 1 year	Server license	Allows use on one server by any number of users with any number of solutions.	2759-132/1119-6012

The software can be used for free during its launch until October 2023. After that, you can activate WAGO Solution Builder by purchasing a license key.

Supported operating systems	Windows 10 (x86, 64-bit) Windows 11 (64-bit)
System Requirements	minimum/recommended
Processor	4 / 8 CPU cores
Memory	8 / 16 GB RAM
Hard disk space	50 / 100 GB
Graphics resolution	1366 x 768 / 1920 x 1080 pixels
Supported devices	PFC200 G2 (750-821x/xxxx-xxxx) Touch Panel 600 (762-xxxx/8000-0002) Edge Controller (752-8303/8000-0002) Compact Controller 100 (751-9301)
Sales channel/delivery type	Via WAGO Download-Center (Link: https://downloadcenter.wago.com/)
Additional information	https://www.wago.com/us/automation-technology/discover-software/solution-builder

Windows® is a registered trademark of Microsoft Corporation.

WAGO Solution Builder

A Holistic Multi-Project Approach

WAGO Solution Builder supports your project, from winning the contract, to commissioning, execution and documentation, all the way to periodic servicing and hardware and software maintenance. The software lets you create multiple building automation solutions in parallel and makes all the data available at all times.

Additional advantages:

- Easy data sharing between WAGO Solution Builder components through interfaces optimized for the workflow
- In addition to automation solutions, couplers, switches, field devices and third-party devices can be integrated into the cross-communication and documented as part of the solution.

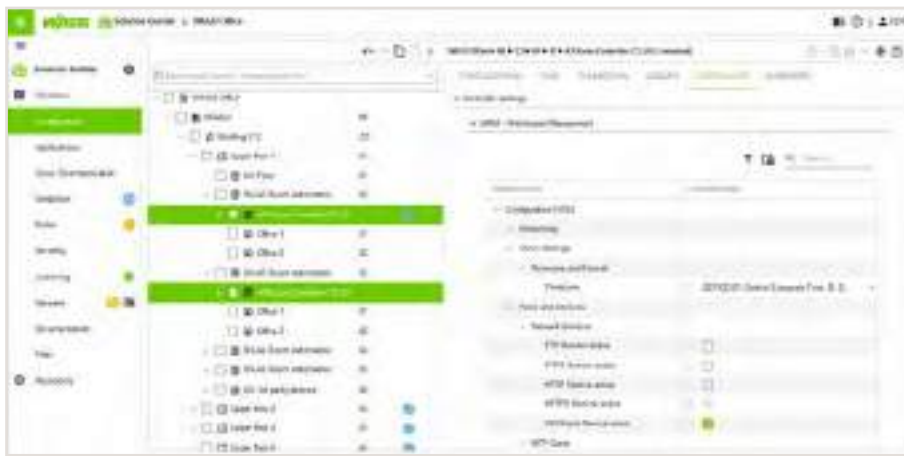

Offline Project Configuration – with Bulk Processing

WAGO Solution Builder was developed for processing large data volumes in building automation.

This has clear advantages for users:

- Set up pattern structures in detail; when reproducing them, you then benefit from clever inheritance mechanisms and logical groupings.
- A solution can contain just a few automation stations or hundreds with thousands of data points.
- Many devices can be set in one step via multiple selection.

Bidirectional Synchronization of the Project Data with the Controllers

When you create a solution with controllers offline, it is transferred to the devices on a job-by-job basis, including your settings and applications. The jobs are processed asynchronously in an outsourced service. What that means is:

- During the transfer process, you can continue to use WAGO Solution Builder without restrictions.
- If parameters on the controllers have been modified during operation, they can be read back in during the next synchronization.

This bidirectionality ensures that no settings get lost.



Project Documentation in One Click

WAGO Solution Builder automatically creates the required project documentation with just one mouse click. You benefit from clear organization:

- All the information entered into the solution, such as IP addresses, applications, firmware versions or the hardware used, is output as a PDF in the project documentation.
- The project documentation layout and degree of detail are easy to customize.

WAGO-I/O-PRO

Engineering Software based on CODESYS V2.3

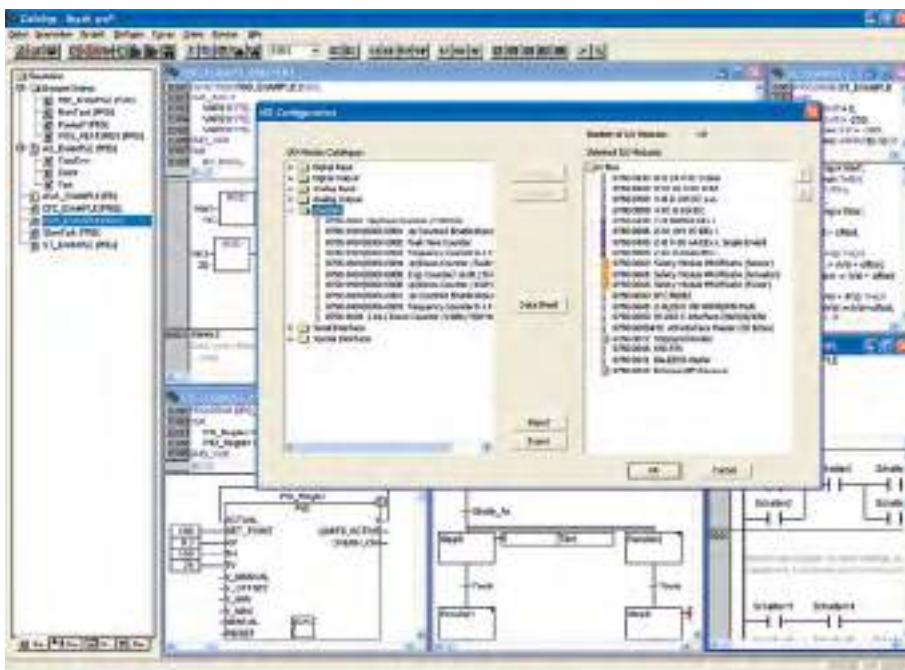

WAGO-I/O-PRO is a programming and visualization tool for control programs. This software is used to develop PLC applications for the WAGO I/O System 750's controllers.

WAGO-I/O-PRO runs in compliance with the IEC 61131-3 standard, which specifies the requirements for a programming system. The IL, SFC, LD, FBD and ST programming languages are supported. The optimal programming language can be chosen for each application.

With extensive programming functions, the software readily meets the increasing demands on control program development, e.g., reusability and modularization.

- Efficiently translate between programming languages
- Automatic variable declaration
- Library management

Integrated test and diagnostic functions also streamline and accelerate the steps for implementing PLC projects.

- Online status display using the program code
- Offline simulation
- Integrated process visualization
- Record and graphically display project variables

WAGO-I/O-PRO also offers the option of programming your existing products from other manufacturers within the CODESYS automation alliance in addition to WAGO's standard programmable CODESYS automation alliance products.

WAGO-I/O-PRO

Version	Delivery Type	Item No.
RS-232 Set	CD-ROM and serial communication cable	759-333
USB Set	CD-ROM and USB communication cable	759-333/000-923

Supported operating systems	Windows 7; Windows 10
System Requirements	
Processor	1 GHz or higher; 32-bit (x86) or 64-bit (x64)
Memory	1 GB of RAM (min.)
Hard disk space	300 MB (min.)
Graphics resolution	1024 x 786 (min.)
Other system requirements	Open serial interface
Delivery type	Installation file (CD-ROM) or download link via WAGO Support possible
For data sheet and additional information, see:	wago.com/759-333 wago.com/759-333/000-923

Windows® is a registered trademark of Microsoft Corporation.

WAGO-I/O-CHECK



WAGO-I/O-CHECK is an easy-to-use Windows application for operating and displaying a WAGO I/O System 750's node without connecting to a fieldbus system.

The software reads the configuration from the node and displays it graphically on the screen. This graphic can be printed together with a configuration list as documentation.

With WAGO-I/O-CHECK, it is possible to display and specify the process data of the I/O modules. The field wiring, including all sensors and actuators, can thus be checked before startup.

For some types of interface, Pt100 and thermocouple modules, application-specific settings can be made, such as the baud rate or sensor types.

The coupler must be connected to a free serial or USB port of the PC using the communication cable supplied in the set with the system to enable communication between WAGO-I/O-CHECK and the node.

WAGO-I/O-CHECK			Supported operating systems	Windows 7; Windows 10
Version	Delivery Type	Item No.	System Requirements	
RS-232 Set	CD-ROM and serial communication cable	759-302	Processor	1 GHz or higher; 32-bit (x86) or 64-bit (x64)
USB Set	CD-ROM and USB communication cable	759-302/000-923	Memory	1 GB of RAM (min.)
			Hard disk space	150 MB (min.)
			Graphics resolution	1024 x 786 (min.)
			Other system requirements	CD-ROM and mouse required
			Delivery type	Installation file (CD-ROM)
			For data sheet and additional information, see:	wago.com/759-302

Windows® is a registered trademark of Microsoft Corporation.

WAGO IO-Link Configurator, WAGO-I/O-CHECK

2

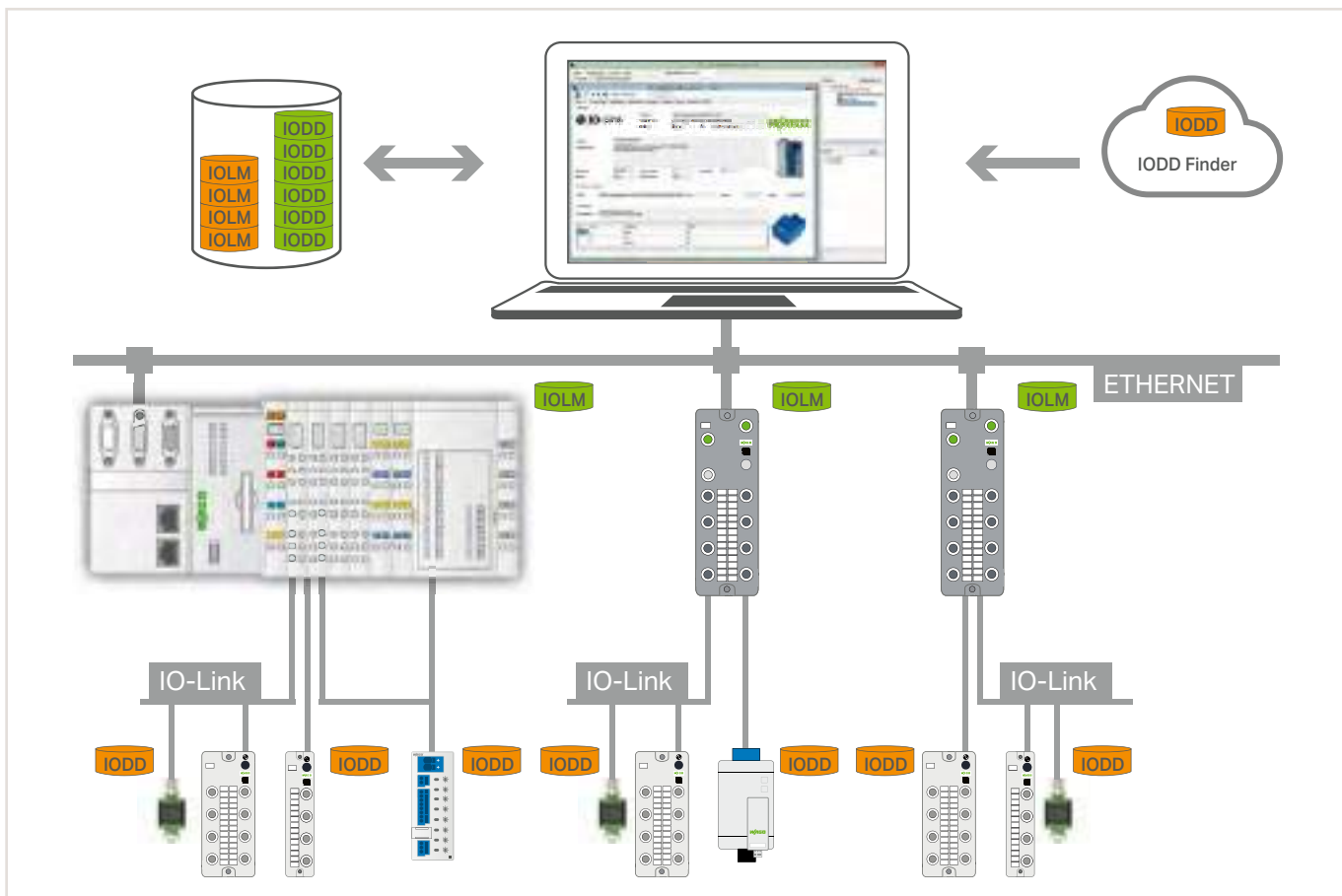

The WAGO IO-Link Configurator enables configuration and parameterization, as well as operation and monitoring of WAGO IO-Link Masters in the WAGO I/O System 750 and WAGO I/O System Field and, in particular, the WAGO IO-Link devices connected to them.

Additionally, IO-Link devices from all third-party manufacturers can be completely configured and operated via the WAGO IO-Link Configurator, as long as they comply with the IO-Link specification. The process data of a product can be graphically visualized and stored in trend curves. Up to eight elements can be selected for visualization, and the data can be recorded for up to 24 hours.

Device description files for the IO-Link Masters (IOLM) or IO-Link Devices (IODD) can be used to integrate new devices into the tool at any time. Convenient access to the IODD finder of the IO-Link user organization is available for the IODDs. It allows an automated and selective download of IODDs when integrating new IO-Link devices.

WAGO IO-Link Configurator can be used either as a standalone program or integrated into engineering systems with a TCI interface and WAGO-I/O-CHECK.

An integrated IODD viewer allows detailed insight into the IODD device description.

The license is assigned to the respective PC on which it is installed (workstation license).

Item Description	
WAGO IO-Link Configurator	Item No.
Single License; Online Activation	2759-106/1121-1000

A single license allows installation on one device. Every additional device requires its own license.

Operating system	Windows 7 or higher
Memory	2 GB or larger
Processor	1 GHz with 32 bits or 64 bits
Free hard disk space	150 MB
Screen resolution	800 x 600 pixels
Delivery type	License certificate by email
For data sheet and additional information, see:	wago.com/2759-106/1121-1000

Internet connection is required for license activation.

WAGO SMI Configurator



The WAGO SMI Configurator is a parameterization software for SMI master modules. You can use the software to commission SMI drives that are connected to SMI master modules.

The SMI Configurator offers functions for commissioning and configuring SMI drives. Besides the online mode, in which you can control the SMI drives directly, you have the option of using the SMI Configurator in offline mode. This includes offline configuration of all SMI drives connected to available SMI master modules within a node, as well as saving and restoring SMI drive configurations from existing CSV addressing files.

You can directly transfer all module settings of an SMI master module to any number of additional SMI master modules with the "Transfer settings" function. Furthermore, you have the option of using the SMI Configurator to generate project documentation and display the log data of a selected SMI master module.

A scan function makes it possible to identify the SMI drives connected to an SMI master module and display the settings in the SMI Configurator. If SMI addresses are missing or there is an address conflict, you can use automatic addressing to assign a new SMI address to all drives automatically, or alternatively use system extension to resolve the address conflict and delete any missing SMI drives.

WAGO SMI Configurator

Download: www.wago.com

Supported operating systems	Windows 7; Windows 10
System Requirements	
Processor	1 GHz (min.)
Memory	1 GB (min.)
Hard disk space	20 MB (min.) for the SMI Configurator and 60 MB for the .NET Framework 4.0
Other system requirements	.NET Framework 4.0
Delivery type	Download

Windows® is a registered trademark of Microsoft Corporation.

WAGO BACnet Configurator

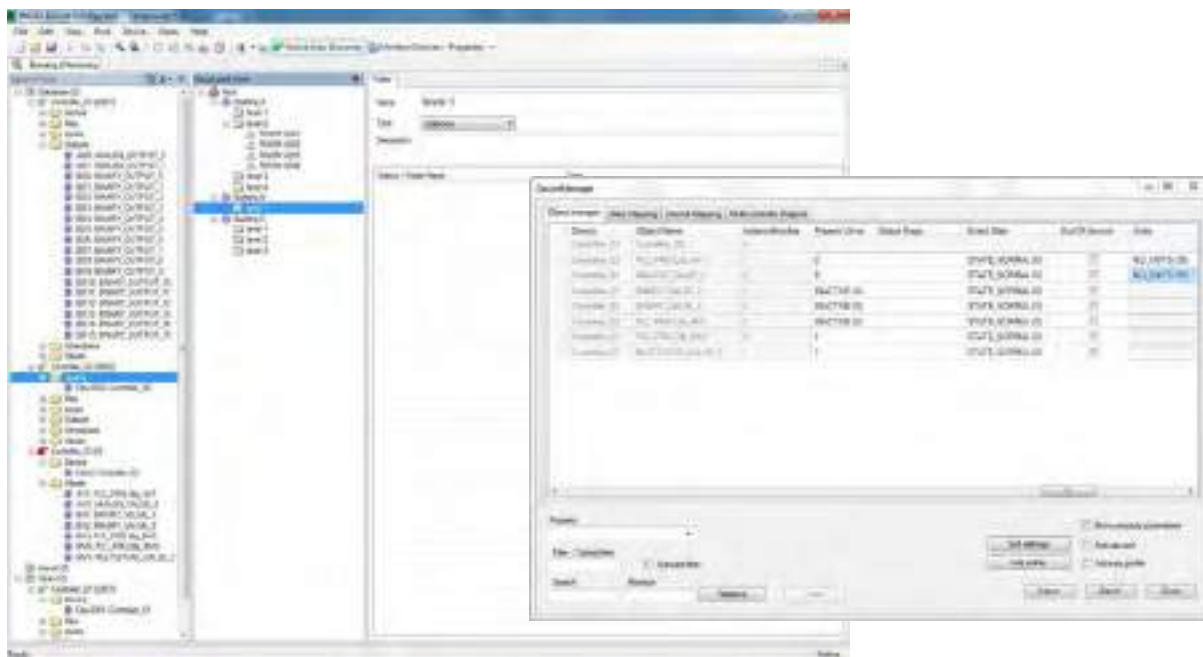

The WAGO BACnet Configurator is an independent commissioning, configuration and management software program. The configurator fully supports the BACnet-specific functions of WAGO's 750-829, 750-830, 750-831 and 750-832, as well as the BACnet/IP PFC200 Controller (750-8212/000-100), which is programmed via *e!COCKPIT*.

The configurator creates and configures WAGO BACnet Controllers and sets up data exchange between the IEC application and BACnet objects. Import and export functions allow further processing of the configuration data.

For integration into existing BACnet networks, the BACnet devices available can be scanned and displayed in a browser; also, data exchange can be implemented for WAGO devices.

Among the configurator's capabilities are the logical structuring of the project and network, addressing of the controller and client/server configuration in every WAGO BACnet Controller.

The devices, objects and configuration data are displayed in a logical, structured network and browser view.

Depending on the function used, both online and offline operation is possible.

The configurator displays all configuration data. To edit BACnet objects, the configurator offers specific table views in which the corresponding properties of the object can be modified. Typical table editing functions, e.g., search/replace, sort, filter and show/hide, are available. The user can upload the updated configuration data to one or more controllers and save as a project.

The configurator provides a browser to view the BACnet object properties and modify current parameters (communicate value changes, write property values, utilize BACnet services, etc.). Additionally, a transaction log window is available for client services.

WAGO BACnet Configurator

The WAGO BACnet Configurator can be downloaded for free at: www.wago.com

Supported operating systems

Windows 7; Windows 10

Windows® is a registered trademark of Microsoft Corporation.

WAGO DALI Configurator

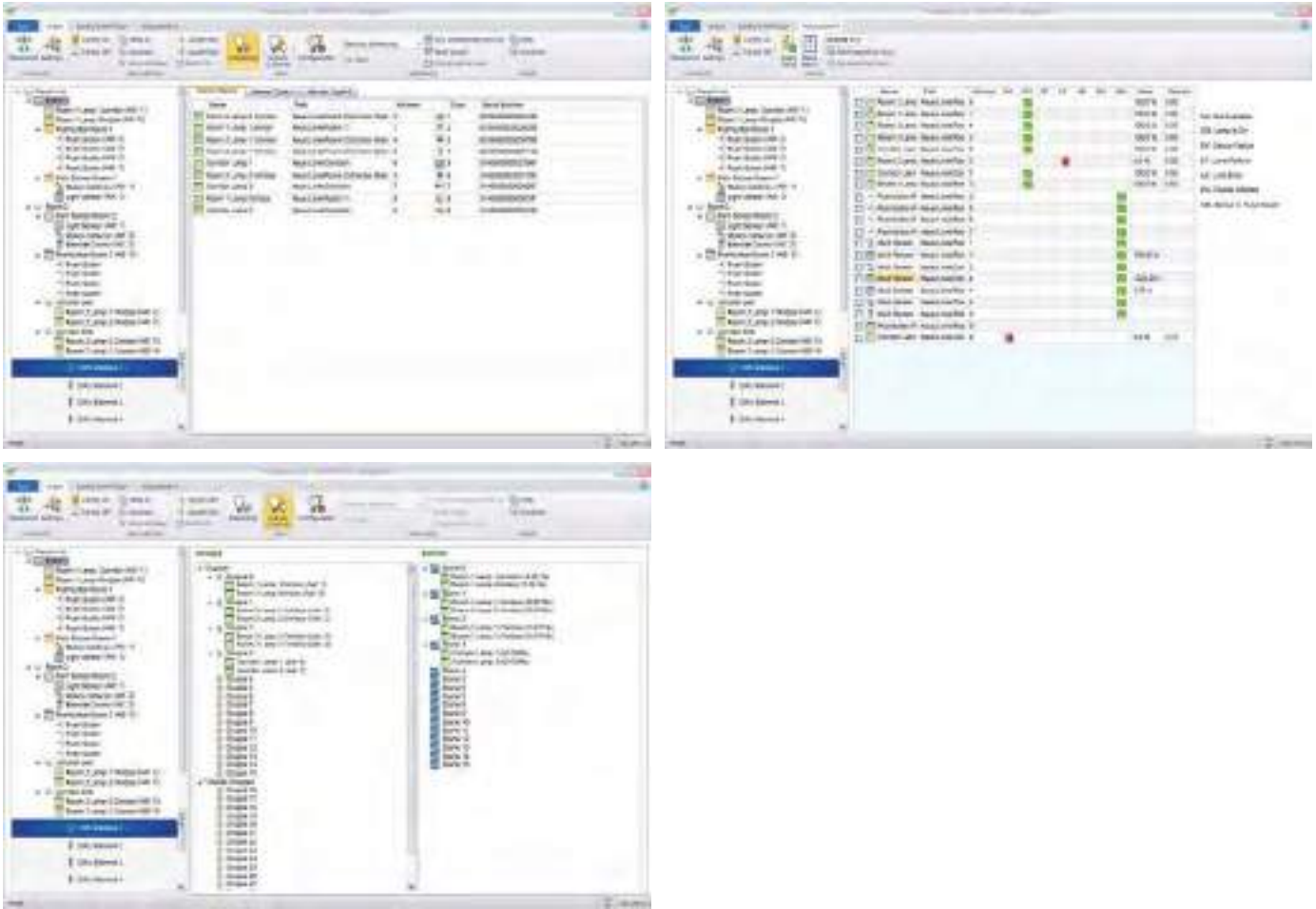

2

The WAGO DALI Configurator simplifies commissioning of a DALI network via 753-647 DALI Multi-Master. The configurator is available as a stand-alone Windows application or for use with WAGO-I/O-CHECK Software.

It provides the following functions: easy commissioning, configuration, service, support and maintenance of a DALI network. Comprehensive backup & restore features, as well as an offline configuration option for the entire DALI network (including ECGs and sensors) are available.

WAGO DALI Configurator
 The WAGO DALI Configurator is available as part of WAGO-I/O-CHECK (Version 3.5.1 or higher) or as a stand-alone version (www.wago.com).

Features	Stand-alone software or for use with WAGO-I/O-CHECK
Commissioning function	Addressing, scenes and group formation; control gear configuration, optional offline configuration, import and export functions, project documentation
Service, support and maintenance functions	Backup & restore, reporting ECG illuminant failures, identification of doubled addresses, diagnostics report
Windows-compliant user interface	Multiple selection for time-optimized configuration and a clearly organized network display with tree structure support different commissioning workflows

WAGO LON® Configurator

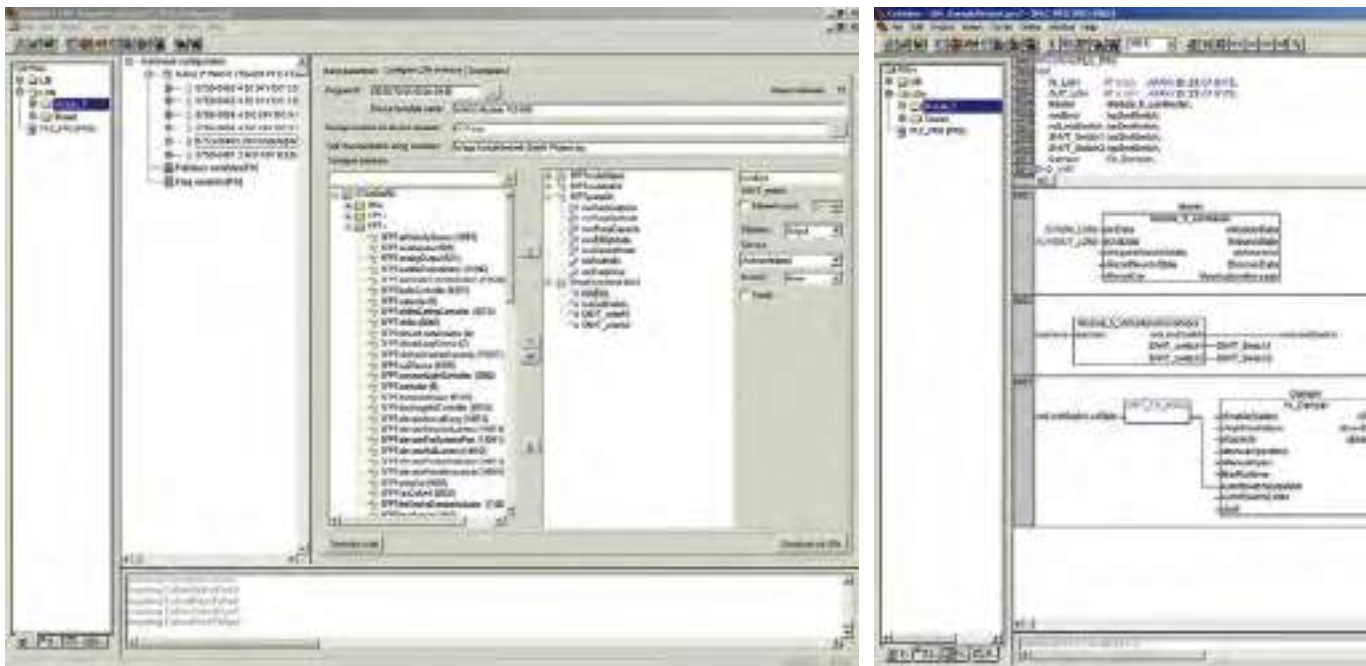

The WAGO LON® Configurator is an integral part of the WAGO-I/O-PRO IEC-61131-3 Programming Environment. The configurator supports both the 753-648 LON® Module's LonWorks® network interface configuration and WAGO-I/O-PRO project integration.

Network variables of any type can be defined. In addition to standard network variable types (SNVTs) and standard configuration property types (SCPTs), user-defined types (UNVTs/UCPTs) and LonMark® functional profiles (FPTs) are also supported. Network variables are defined using the types and objects of the LonMark® resources installed on your computer.

IEC-61131-3 function blocks are automatically created in the IEC application, simplifying operation. The function blocks represent the LON® network interface in the IEC application. When starting the controller, both network variable interface and configuration data are automatically downloaded into the I/O module.

An external interface file (XIF) is created for offline configuration in a network management tool.

WAGO LON® Configurator

The WAGO LON® Configurator is available as part of WAGO-I/O-PRO (Version 2.3.9.34 or higher)

- Integral part of WAGO-I/O-PRO programming software
- Defines and implements a LON® network interface
- Automatically generates IEC 61131-3 function blocks to represent the LON® network interface within an IEC application
- Downloads both network interface and configuration data when controller is started
- Configuration check and test
- Generates XIF files

WAGO ETS Plug-in

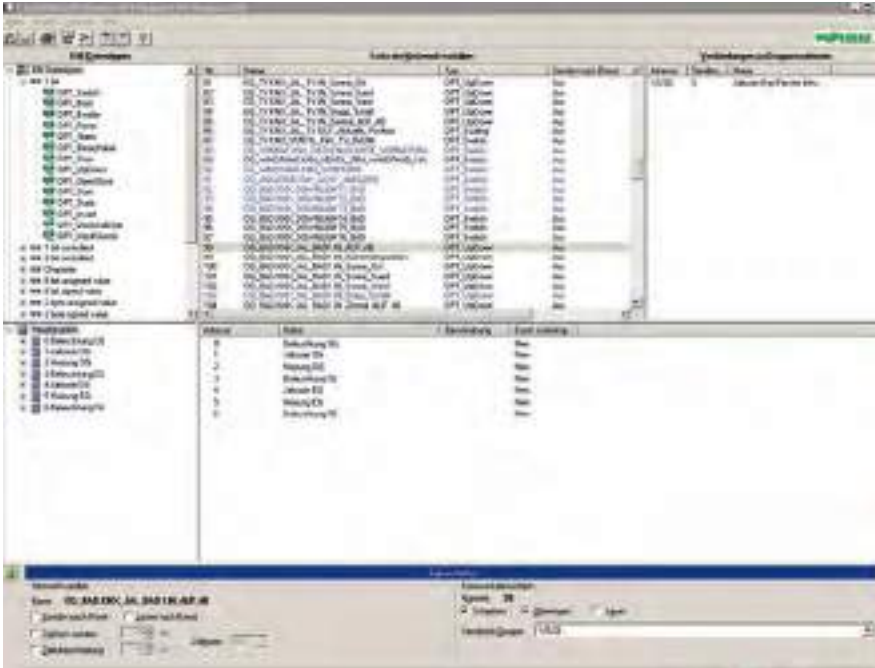

The WAGO ETS Plug-in is a WAGO ETS product database extension that allows the use of WAGO devices, such as the 753-646 KNX/EIB/TP1 Interface, 750-889 KNX IP Controller and KNXnet/IP Router (consisting of KNX/EIB/TP1 Interface and KNX IP Controller).

The software's enhanced structure offers intuitive navigation – providing both new and experienced ETS users with exceptional usability.

The WAGO ETS Plug-in provides three clearly structured user interfaces for the various devices. Depending on the mode selected, either the KNX/EIB/TP1 Module, KNX IP Controller or the KNXnet/IP Router (IP Controller with KNX/EIB/TP1 Module in first position) are supported.

In the graphical interfaces, device parameters are easy to configure. Only the options pertaining to the selected device are displayed. During software development, creating a convenient and time-saving graphical user interface was heavily emphasized – and this is beneficial when assigning communication objects to group addresses. Two different drag-and-drop options and a context menu with automatic filter function are available allowing users to select their favorite procedure.

WAGO ETS Plug-in

The WAGO ETS Plug-in can be downloaded for free at:
www.wago.com

Supported operating systems	Windows 7; Windows 10
Other	The plug-in requires the ETS product database.
Configuration	
KNX/EIB/TP1 Module	Load/assign IEC variables (communication objects); Create/configure group addresses
KNX IP Controller	Allocate IP addresses; Download IEC application to controller; Load/assign IEC variables (communication objects); Create/configure group addresses
KNXnet/IP Router	Allocate IP addresses; Set routing multi-cast addresses; Filter/transmit telegrams

Windows® is a registered trademark of Microsoft Corporation.

Runtime Software – Libraries based on CODESYS V3

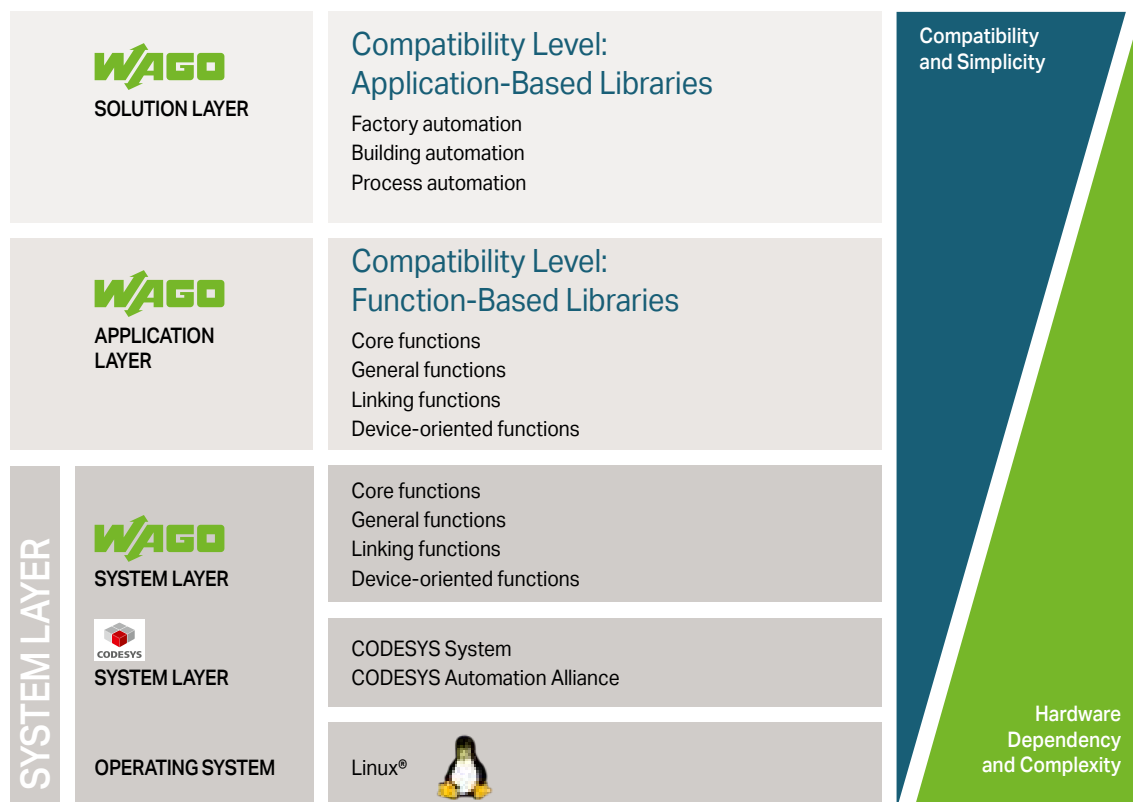

Runtime Software Controls the Machine

Machines and systems are controlled by runtime software that determines behavior, while enabling both operation and current status monitoring for the user. It also transmits operating data to higher-level systems. Unlike engineering software, runtime software operates continuously – it is a part of the machine and ensures correct operation.

Ready-to-Use Function Blocks Save Development Time

Comprehensive, tried-and-tested software function blocks (IEC libraries) expedite development. Thus, CODESYS is supplemented with comprehensive IEC libraries.

Essentially, the libraries are divided into three abstraction layers:

The solution layer primarily contains complete, easy-to-use software solutions for production, building and process automation.

The application layer contains technology functions, e.g., for communication, that are ideal for convenient, easy application. The system layer provides experts with complete system access.

The upper layers are separated by compatibility levels. Essentially, this enables software to be developed independently of the hardware it will be used on. This provides the greatest degree of flexibility in selecting the right device for the right application, while retaining a uniform software base. It also provides investment security.

Function Modules and Libraries

available in the WAGO Download Center

Runtime Software – Libraries

WAGO-I/O-PRO (based on CODESYS V2.3)

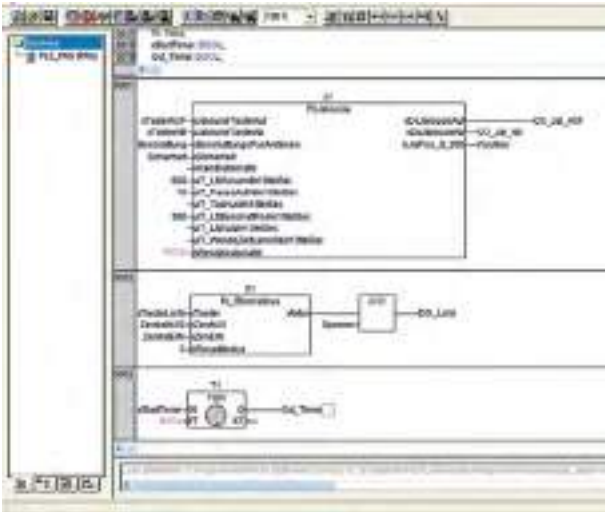

Room Applications
Integrated into WAGO-I/O-PRO Software

This library contains custom function blocks for building automation, which accelerate the programming of building applications.

- Lighting
- Dimming
- Lighting scenes
- Constant light control
- Sun protection
- Shading
- Other applications



Application Notes
Download: Current application notes available at: www.wago.com

The application notes contain function blocks (FBs) for communication applications.

- KNX/EIB
- DALI
- EnOcean Radio Technology
- Modbus
- M-Bus
- MP-Bus
- SMI
- LonWorks®
- Email
- SMS
- Other applications

Runtime Software – Libraries

WAGO-I/O-PRO (based on CODESYS V2.3)

2

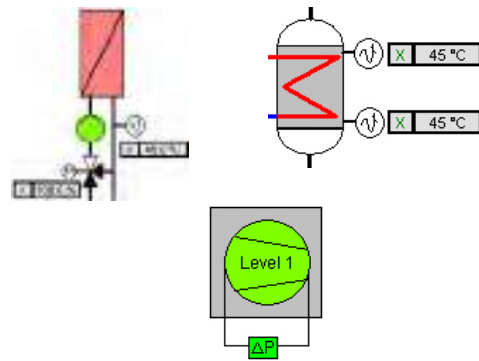
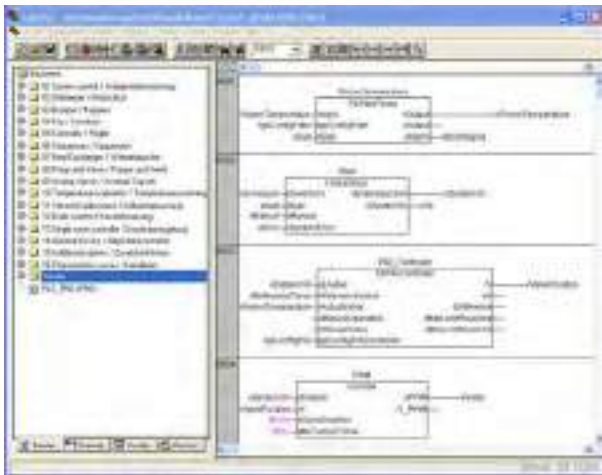

Graphical elements for HVAC applications

Heating, Ventilation, Air Conditioning

Integrated into WAGO-I/O-PRO Software

This library contains function blocks (FBs) to create automation applications for complex heating, ventilation and air-conditioning (HVAC) systems.

These include: fault monitoring, starter circuits, monitoring frost protection systems, fan control (stepped/continuous), air mixture valve control, air heater/cooler control, cascade control of room/feed air temperature, free night cooling, summer/winter compensators, enthalpy calculations, PID controllers, filter monitoring, blockage protection, heating circuit control, heat recovery control, boiler control (stepped/continuous), boiler sequence, domestic hot water control, start/stop optimization, humidification and dehumidification (climate) and more.

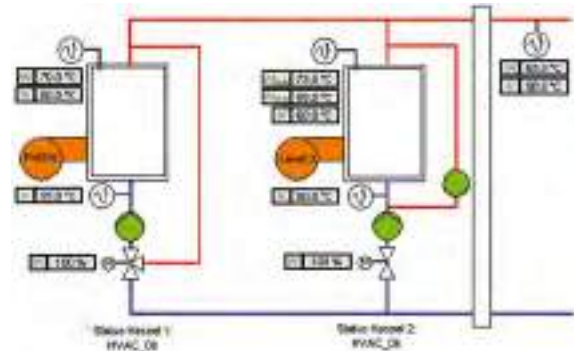
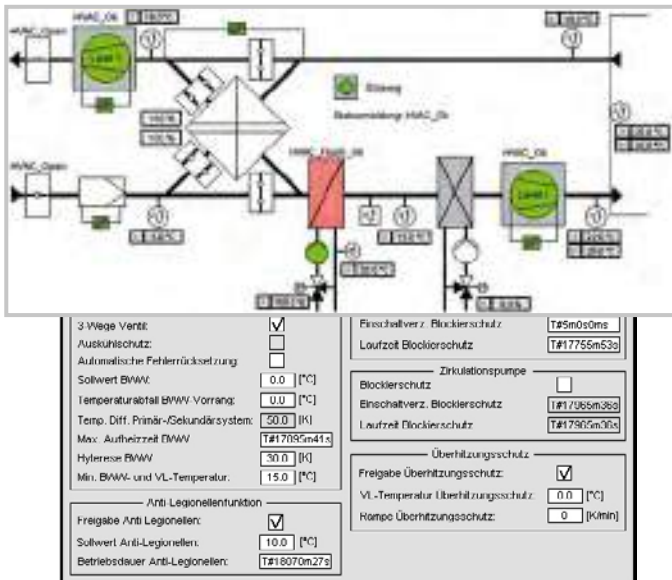

Boiler sequence control

System Macros

Download: Current application notes available at: www.wago.com

- District heating transfer station macros
- Boiler macros
- Heating circuit macros
- Drinking water heating macros
- Ventilation macros

Runtime; Multi-Cloud Connectivity

Function:

MQTT is a powerful IoT protocol that has become standard in many industrial automation applications. Both PFC200 Controller (Generation 2) and Touch Panel 600 support an MQTT connection by default. "Multi-Cloud Connectivity" enables the parallel connection of a device to two different cloud systems, IoT platforms or MQTT brokers, allowing different tasks to be implemented in the appropriate cloud application. For example, device management can be performed within WAGO Cloud. At the same time, specific tasks can be implemented in another cloud-based solution, e.g., IBM Watson, Amazon Web Services (AWS) or other specialized IoT platform. Data can also be split up, allowing critical data to go to a local MQTT broker and less critical data to a cloud.

Your Benefits:

- More options and flexibility
- Simple error analysis via configuration in WBM, programming in CODESYS
- Taking advantage of two cloud solutions/IoT platforms

Use:

The license is registered in WAGO Upload and loaded onto a device. No other installation steps are required.

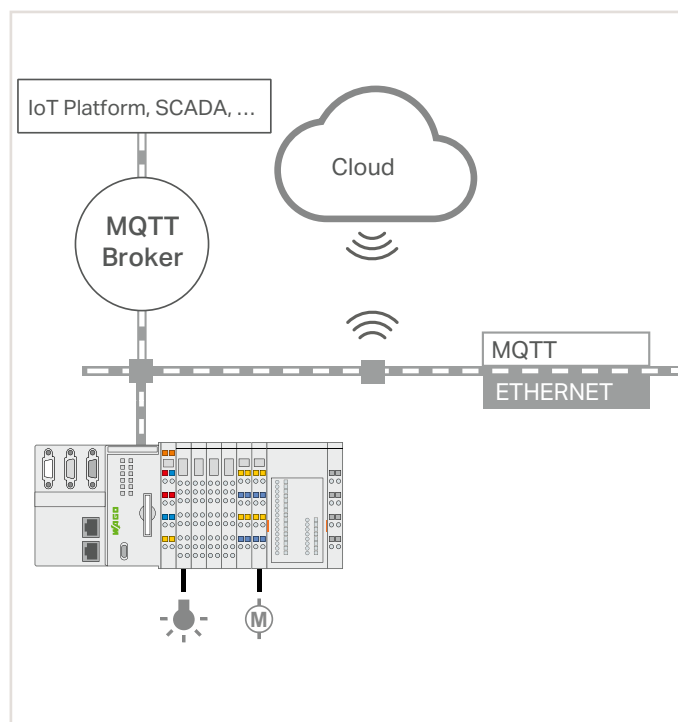
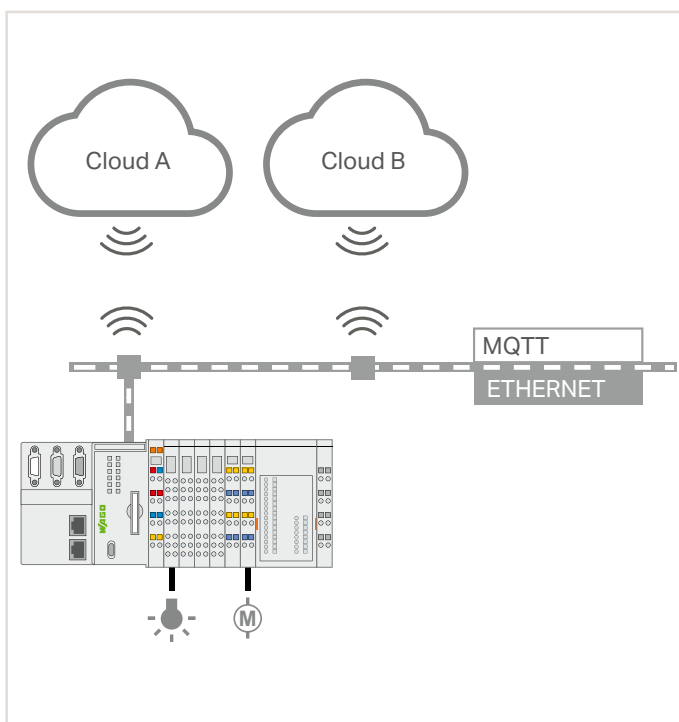

Item Description	
Runtime; Multi-Cloud Connectivity	Item No.
Single License; Online Activation	2759-248/211-1000
Compatible Devices	
Controller PFC200; G2	750-821x
Compact Controller 100	751-9301
Touch Panel 600; Control Panel	762-x3xx/8000-002
Edge Controller	752-8303/8000-002

Besides the basic controller variants listed here, the license can also be used on these controllers' variants. For details, see the product information of the corresponding controller.

For detailed information on the controllers and touch panels, go to: www.wago.com/item-numbers

Minimum firmware version	17
Delivery type	License certificate by email
For data sheet and additional information, see:	www.wago.com/2759-248/211-1000

An Internet connection to the PC that's equipped with CODESYS or the WAGOupload tool may be required for license activation. A single license allows installation on one device. One license per device is required.

Runtime; Sparkplug

Function:

MQTT is a powerful IoT protocol that has become standard in many industrial automation applications. WAGO's PFC200 Controller (Generation 2) supports the MQTT protocol and the Sparkplug specification that defines both topic and payload, allowing the controller to exchange data directly with Sparkplug-enabled systems (e.g., SCADA). This requires a license for the controller.

Configuration is performed via the controller's Web-Based Management and the variables to be transmitted or received are defined by the CODESYS Engineering Software and its library.

Benefits:

- The PFC200 communicates directly with Sparkplug-enabled systems (e.g., SCADA) without requiring any additional gateway.

Use:

The license is registered in WAGO Upload and loaded onto a device. No other installation steps are required.

Technical Data:

- Sparkplug B payload
- Publish data
- Subscribe to data

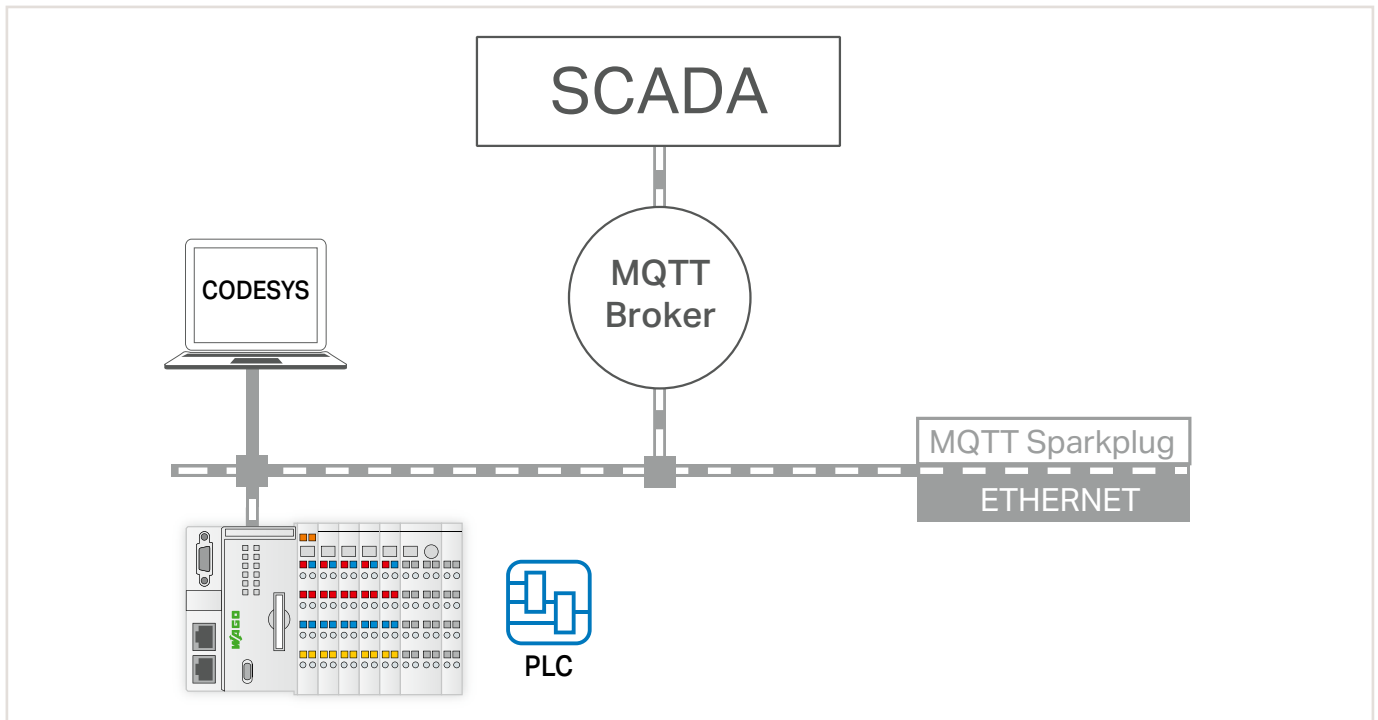

Item Description	
Runtime; Sparkplug	Item No.
Single License; Online Activation	2759-247/211-1000
Compatible Devices	
Controller PFC200; G2	750-821x
Compact Controller 100	751-9301
Touch Panel 600; Control Panel	762-x3xx/8000-002
Edge Controller	752-8303/8000-002

Minimum firmware version	12
Delivery type	Licence certificate via email
For data sheet and additional information, see:	wago.com/2759-247/211-1000

An Internet connection to the PC that's equipped with CODESYS may be required for license activation.
 A single license allows installation on one device.
 Every additional device requires its own license.

Besides the basic controller variants listed here, the license can also be used on these controllers' variants. For details, see the product information of the corresponding controller.
 For detailed information on the controllers and touch panels, go to: www.wago.com/item-numbers

Runtime; MicroBrowser

Function:

The MicroBrowser extends the application range of the Touch Panels 600. With the Runtime MicroBrowser license, each Touch Panel can also now display the Java-based visualization of CS2.3 Controllers.

Benefits:

- MicroBrowser integration also allows the customer to use the powerful Touch Panel 600 in previous systems.

Use:

The license is registered in WAGO Upload and loaded onto a device. No other installation steps are required.

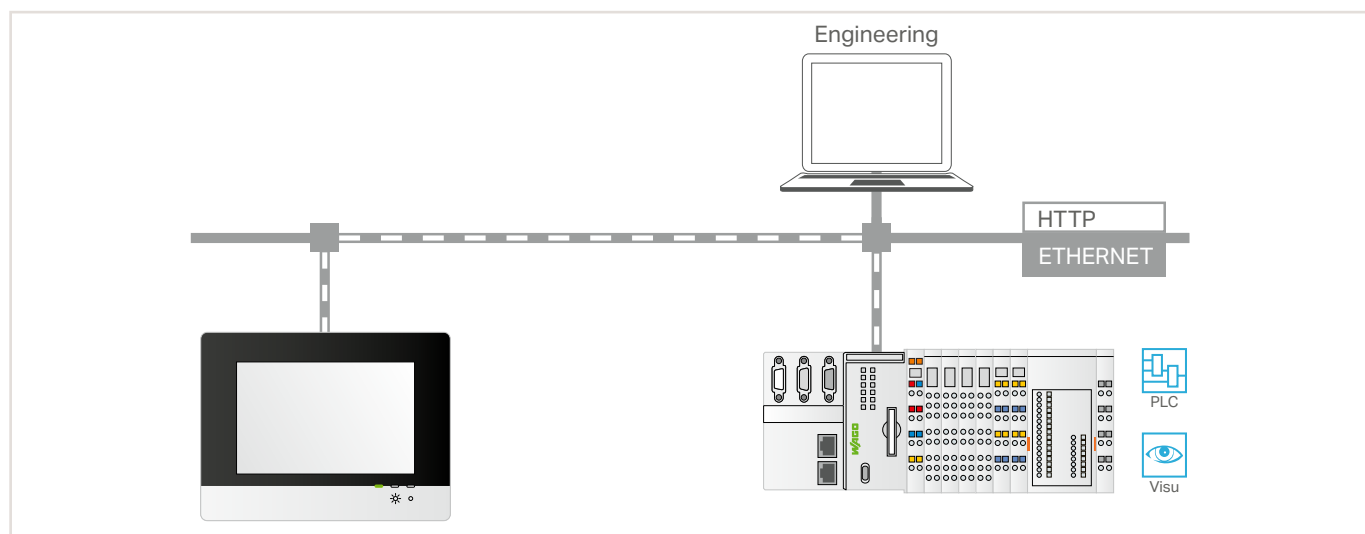

Item Description	
Runtime; MicroBrowser	Item No.
Single License; Online Activation	2759-230/211-1000
Compatible Devices	
Touch Panel 600 Standard Line	762-4xxx/xxxx-xxxx
Touch Panel 600 Advanced Line	762-5xxx/xxxx-xxxx
Touch Panel 600 Marine Line	762-6xxx/xxxx-xxxx

xx is a wildcard; the license applies to all Touch Panel sizes.

Other required software	Firmware version 18 or higher (Touch Panel 600)
Delivery type	License certificate via email (the firmware already contains the software itself)
For data sheet and additional information, see:	wago.com/2759-230/211-1000

An Internet connection to the PC that's equipped with CODESYS or the WAGOupload tool may be required for license activation. A single license allows installation on one device. One license per device is required.

Runtime; BACnet/IP

Function:

"Building Automation and Control Networks" (BACnet) is a data transfer protocol for building automation that simplifies communication between products from different manufacturers. The PFC200 Controller (2nd generation) or WAGO Touch Panel can be operated as a BACnet building controller and supports the B-BC device profile with all major BACnet objects and interoperability building blocks (BIBBs). The device communicates via BACnet/IP and offers the functionality of a BACnet Client and BACnet Server.

To use BACnet/IP, it is necessary to equip the device with a license.

The BACnet network is configured using the WAGO BACnet Configurator and the Engineering Software.

Benefits:

- Use the device as a BACnet Building Controller (B-BC)
- Control and detect distributed I/O signals from WAGO BACnet/IP Couplers via BACnet Fieldbus Protocol
- Data exchange with other BACnet Devices as a BACnet Client or Server

Use:

The license is registered in WAGO Upload and loaded onto a device. No other installation steps are required.

Technical Data:

See "Protocol Implementation Conformance Statement" (PICS)

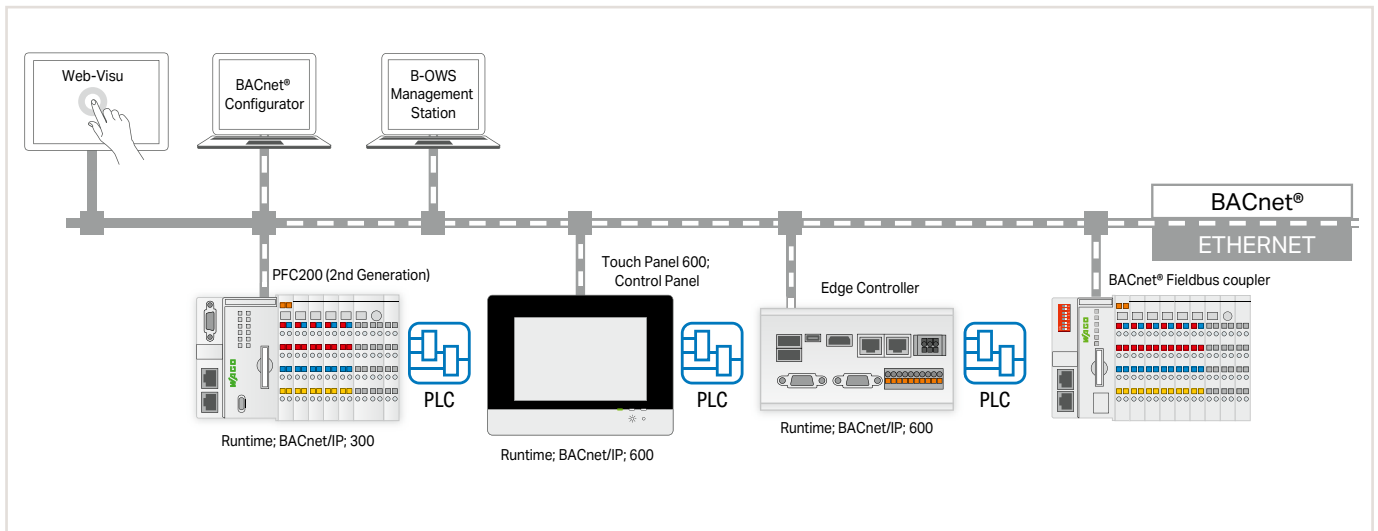

Item Description	
Runtime; BACnet/IP; 300; without limitation of the BACnet objects*	Item No.
Single License; Online Activation	2759-283/211-1000
Runtime; BACnet/IP; 300; M; up to 256 BACnet objects	
Single License; Online Activation	2759-2283/211-1000
Runtime; BACnet/IP; 300; S; up to 48 BACnet objects	
Single License; Online Activation	2759-2273/211-1000
Compatible Controllers	
PFC200; G2; 4ETH	750-8210
PFC200; G2; 2ETH 2SFP	750-8211
PFC200; G2; 2ETH RS	750-8212
PFC200; G2; 2ETH CAN	750-8213
PFC200; G2; 2ETH RS CAN DPS	750-8216
PFC200; G2; 2ETH RS; 4G	750-8217

Item Description	
Runtime; BACnet/IP; 600; without limitation of the BACnet objects*	Item No.
Single License; Online Activation	2759-286/211-1000
Runtime; BACnet/IP; 600; M; up to 256 BACnet objects	
Single License; Online Activation	2759-2286/211-1000
Runtime; BACnet/IP; 600; S; up to 48 BACnet objects	
Single License; Online Activation	2759-2276/211-1000
Compatible Devices	
Touch Panel 600 Standard Line	762-43xx/8000-002
Touch Panel 600 Advanced Line	762-53xx/8000-002
Touch Panel 600 Marine Line	762-63xx/8000-002
WAGO Edge Controller	752-8303/8000-002

Minimum firmware version	Firmware (16), 2759-x283/211-1000, 2759-x286/211-1000 Firmware (18), 2759-x283/211-1000, 2759-x286/211-1000
Delivery type	Licence certificate via email
For data sheet and additional information, see:	wago.com/2759-0283/211-1000 wago.com/2759-0286/211-1000

An Internet connection to the PC that's equipped with CODESYS may be required for license activation. A single license allows installation on one device. One license per device is required.

BACnet® is a registered trademark of the American Society of Heating, Refrigerating and Air Conditioning Engineers, Inc. (ASHRAE).

*Number of BACnet objects: without limitation – but depends on the application used

x/xxxx-xxxx or x/0040-000x is a placeholder, the license is also applicable for variants of the controllers and touch panels.

Runtime; OPC UA Server Extended

Function:

“OPC Unified Architecture” (OPC UA) is a platform-independent and service-oriented architecture. It is used to describe and transport data. Because the services are independent, devices from different manufacturers can be interconnected.

The OPC UA server can release PFC200 Series, Touch Panel 600 and Edge Controller runtime data to a product in the network when it meets the required preconditions. The device must have an ETHERNET interface that can be used for communication and have the memory capacity and processing time required by the server.

The “OPC UA Server Extended” license activates an extended range of functions for the OPC UA server.

Extended functional range:

Mapping the “PLCopen” information model to any other information model.

By default, WAGO controllers use the “PLCopen” information model to provide data for other applications. The OPC UA Mapping Editor can be used to map this information model to any other OPC UA model, for example, to OPC UA base models such as “Robotics” or “Euro-map77”.

To use other, arbitrary information models, it is necessary to equip the device with a license.

Mapping to other, arbitrary information models is performed via the WAGO OPC UA Mapping Editor.

Benefits:

Mapping the “PLCopen” information model to any other information models

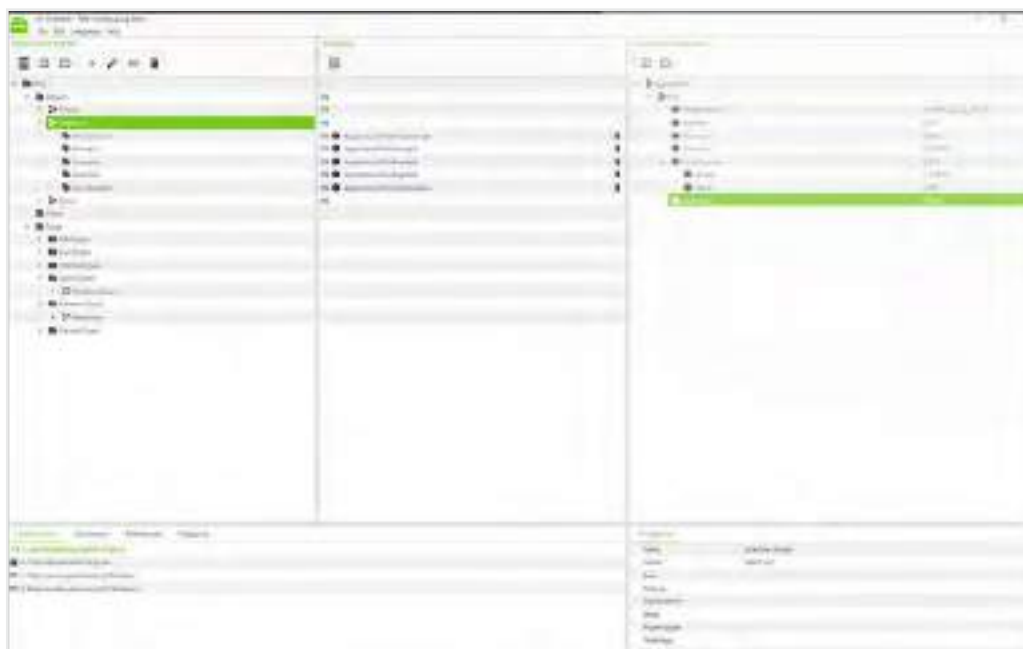

Item Description	
Runtime; OPC UA Server Extended; 300	Item No.
Single License; Online Activation	2759-2233/211-1000
Compatible Controllers	
PFC200; G2	750-821x/xxxx-xxxx
Item Description	
Runtime; OPC UA Server Extended; 600	Item No.
Single License; Online Activation	2759-2236/211-1000
Compatible Devices	
Touch Panel 600 Standard Line	762-43xx/8000-002
Touch Panel 600 Advanced Line	762-53xx/8000-002
Touch Panel 600 Marine Line	762-63xx/8000-002
WAGO Edge Controller	752-8303/8000-002

xx is a wildcard; the license applies to all Touch Panel sizes.

Minimum firmware version	Firmware (18) Patch 3
Delivery type	License certificate per email
For data sheet and additional information, see:	wago.com/2759-2233/211-1000 wago.com/2759-2236/211-1000

An Internet connection to the PC that's equipped with CODESYS may be required for license activation.

A single license allows installation on one device.

Every additional device requires its own license.

OPC UA is a registered trademark of the OPC Foundation.

OPC UA Mapping Editor



2

Functions:

The OPC UA Mapping Editor for WAGO's Linux®-based controllers offers even greater flexibility for leveraging the benefits of OPC UA communication. These "companion specifications" have been defined to cope with the demands of different industries having similar products and machines. These specifications primarily describe information models.

The OPC UA Mapping Editor allows you to modify the information model that specifies how the WAGO OPC UA server provides the data; you can also map the data onto any information model. For this purpose, a symbol configuration is generated with CODESYS. After the symbol configuration is loaded, the variables are mapped to the newly created information model. Once the resulting mapping is loaded onto the controller, it's easy to implement OPC UA communication for different applications and performance demands. Customer-specific adaptations are also possible, even if they don't correspond to any particular specification.

Operation on the controller requires an "Extended" Runtime license for the WAGO OPC UA Server (2759-2233/211-1000 or 2759/2236/211-1000) on the device. Mapping Editor, which creates the information model, is free of charge.

Benefits:

- Adaptation of the information model provided by the OPC UA Server to any information model
- Flexible use of OPC UA

Use:

The OPC UA Mapping Editor has been developed for use on Windows 10-based systems.

Item Description	
OPC UA Mapping Editor	
Download: www.wago.com	
Supported Controllers	Item No.
2nd Generation PCF200	750-821x
TP600 Control Panels	752-430x
Edge Controller	752-8303/8000-002

System Requirements	
Operating system	Windows 10
Memory	4 GB
Free hard disk space	800 MB
Processor	Dual-core CPU
Screen resolution	Minimum: 1,366 x 768 pixels Recommended: 1,920 x 1,080 pixels
Minimum firmware version	FW18 patch 3
Delivery type	Download

OPC UA Mapping Editor is free of charge. However, running it on a controller requires an "Extended" Runtime license for the WAGO OPC UA Server.

Runtime; OPC UA Client

Function:

OPC Unified Architecture allows you to exchange data securely between different devices. OPC UA is a manufacturer-independent communication protocol that defines semantic annotation in addition to data transmission. The WAGO OPC UA Client allows data from an OPC UA Server to be included in the IEC application. The interface to your application is a function block library, which is implemented according to PLCopen.

To use the OPC UA client, it is necessary to license the device.

Benefits:

- Use the device as an OPC UA client
- Read/write OPC UA data points of an OPC UA server via the IEC application

Use:

The license is registered in WAGO Upload and loaded onto a device. No other installation steps are required.

Technical Data:

The following PLCopen modules are supported:

- Connect and Disconnect
- namespaceGetIndexList
- NodeGetHandleList and NodeReleaseHandleList
- ReadList and WriteList



Item Description	
Runtime; OPC UA Client	Item No.
Single License; Online Activation	2759-2230/211-1000
Compatible Controllers	
Controller PFC200; G2	750-821x/xxxx-xxxx
Controller PFC200; G2; XTR	750-821x/0040-0000

Delivery type	License certificate per email
For data sheet and additional information, see:	wago.com/2759-2230/211-1000

An Internet connection to the PC that's equipped with CODESYS may be required for license activation.

A single license allows installation on one device. Every additional device requires its own license.

OPC UA is a registered trademark of the OPC Foundation.

Runtime; IEC 60870 Slave

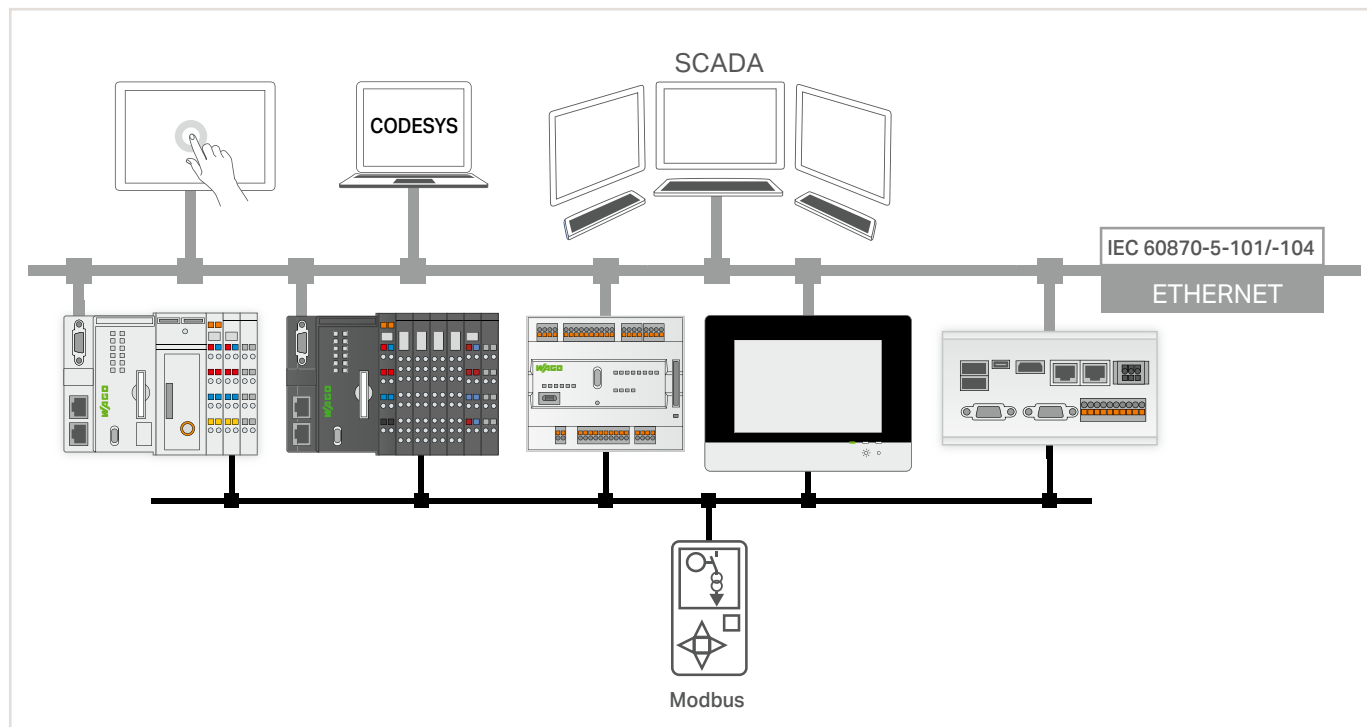

Function:

Communication according to the IEC 60870 protocol can be conveniently parameterized with the configurator. For this purpose, the CODESYS development environment is extended by the WAGO Telecontrol Package. The configurator sets up IEC 60870 objects, while configuring data exchange to the PLC application or I/O modules. Import and export functions in CSV format allow configured data to be transmitted to other engineering tools. With this license, the IEC 60870-5-101 and -104 Protocols can be activated on the slave. This permits the creation of gateways that convert one protocol into another, e.g., allowing protection devices to be read out via IEC 60870-5-103 and data to be transmitted to the network control system via IEC 60870-5-104. The time on the telecontrol substation (slave) can be directly synchronized via either the IEC 60870 Protocol with object 103 or via (S)NTP. IEC 60870-5-101/-104 Information Objects can be used to monitor the direction of single, double and step messages – bit patterns, counter values, as well as normalized, scaled and floating-point measurement values can also be used. All information objects can be transmitted with or without a time stamp. This also applies to information objects in the control direction.

An IEC 60870-5-104 Slave can simultaneously maintain up to four connections to the control system (master).

Your Benefits:

- Use the Controller as a telecontrol substation (slave) on an IEC 60870-5-101/-104 Control System (master).
- Create a gateway application to transfer data from IEC 60870-5-103 Protection Devices to an IEC 60870-5-101/-104 Control System.

Use:

The license is registered in WAGO Upload and loaded onto a device. No other installation steps are required.

Technical Data:

See Section "Functionality of the WAGO Protocol Library according to IEC 60870-5-101, and -104" in Product Manual "Planning IEC 60870 with the Telecontrol Configurator"

Item Description	
Runtime; IEC 60870 Slave	Item No.
Single License; Online Activation	2759-290/211-1000
Compatible Controllers	
Controller PFC200; G2	750-821x/xxxx-xxxx
Controller PFC200; G2; XTR	750-821x/0040-000x
Compact Controller 100	751-9301
Touch Panel 600 Standard Line	762-43xx/8000-002
Touch Panel 600 Advanced Line	762-53xx/8000-002
Touch Panel 600 Marine Line	762-63xx/8000-002
WAGO Edge Controller	752-8303/8000-002

Other required software	CODESYS V3.5 SP16 and higher
Delivery type	Licence certificate via email
For data sheet and additional information, see:	wago.com/2759-290/211-1000

An Internet connection to the PC that's equipped with CODESYS may be required for license activation.

A single license allows installation on one device.

Every additional device requires its own license.

x/xxxx-xxxx or x/0040-000x is a placeholder, the license is also applicable for variants of the controllers and touch panels.

The controllers 750-8212/025-001, 750-8212/025-002, 750-8212/040-001 and 750-8216/025-001 include the telecontrol licenses as delivered.

Runtime; IEC 60870 Master

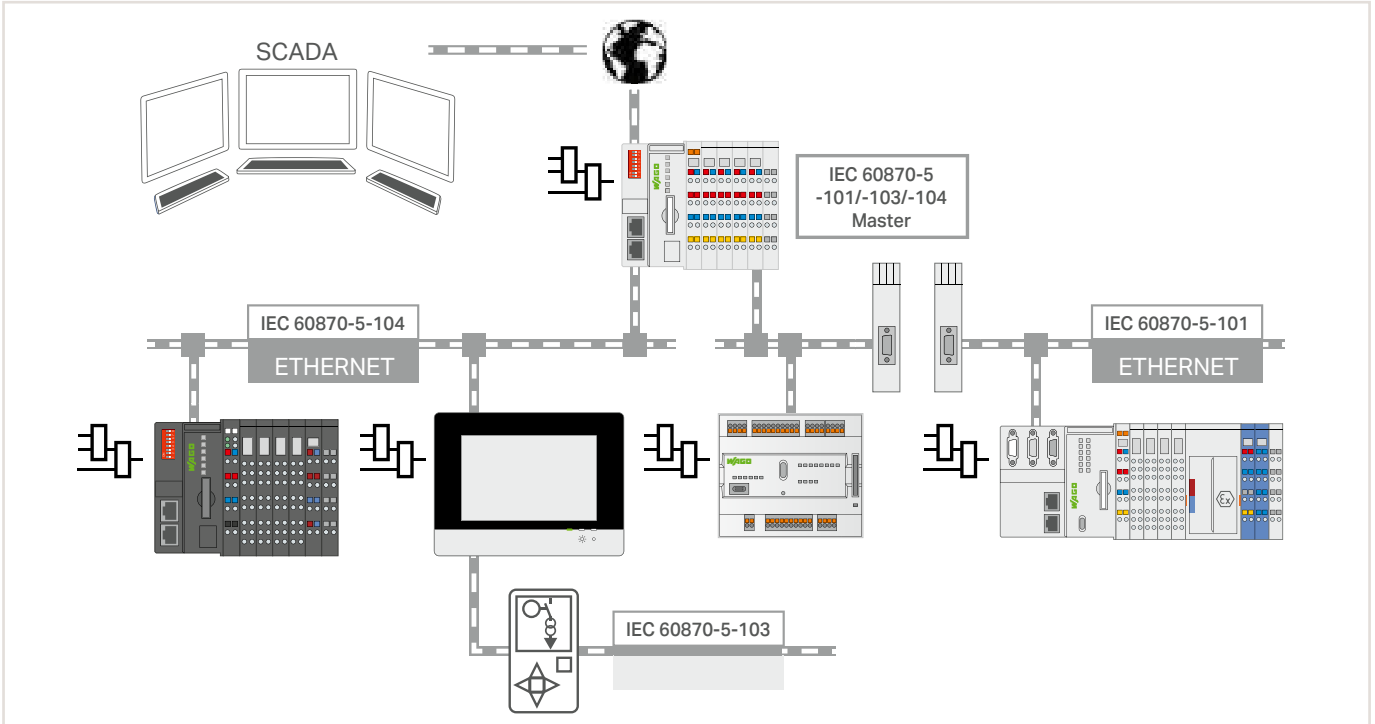

Function:

Communication according to the IEC 60870 protocol can be conveniently parameterized with the configurator. For this purpose, the CODESYS development environment is extended by the WAGO Telecontrol Package. The configurator sets up IEC 60870 objects while configuring data exchange to the PLC application or I/O modules. Import and export functions in CSV format allow configured data to be transmitted to other engineering tools. With this license, the IEC 60870-5-101, -103 and -104 Protocols can be activated on the master. This permits the creation of gateways that convert one protocol into another, e.g., allowing protection devices to be read out via IEC 60870-5-103 and data to be transmitted to the network control system via IEC 60870-5-104.

IEC 60870-101/-104 Information Objects can be used to monitor the direction of single, double and step messages – bit patterns, counter values, as well as normalized, scaled and floating-point measurement values can also be used. All information objects can be received with or without a time stamp. This also applies to information objects in the control direction.

The IEC 60870-5 Master L can support connections to up to 16 IEC 60870-5 Slave Devices.

Your Benefits:

- Use the WAGO controller as a telecontrol master to read data from IEC-60870-5-101/-104 Field Devices or IEC-60870-5-103 Protection Devices (slaves) and process it locally in the controller.
- Create a gateway application to use this master function to forward read data to a higher-level control system or cloud. This may require additional software licenses, such as the WAGO IEC 60870 Slave, DNP 3 Slave, Sparkplug or WAGO Cloud.

Use:

The license is registered in WAGO Upload and loaded onto a device. No other installation steps are required.

Technical Data:

See Section "Functionality of the WAGO Protocol Library according to IEC 60870-5-101, and -104" in Product Manual "Planning the IEC 60870 Protocol with the Telecontrol Configurator"

Item Description	
Runtime; IEC 60870 Master M	Item No.
Single License; Online Activation	2759-293/211-1000
Compatible Controllers	
Controller PFC200; G2	750-821x/xxxx-xxxx
Controller PFC200; G2; XTR	750-821x/0040-000x
Compact Controller 100	751-9301
Item Description	
Runtime; IEC 60870 Master L	Item No.
Single License; Online Activation	2759-296/211-1000
Compatible Devices	
Touch Panel 600 Standard Line	762-43xx/8000-002
Touch Panel 600 Advanced Line	762-53xx/8000-002
Touch Panel 600 Marine Line	762-63xx/8000-002
WAGO Edge Controller	752-8303/8000-002

Other required software	CODESYS V3.5 SP16 and higher
Delivery type	Licence certificate via email
For data sheet and additional information, see:	wago.com/2759-296/211-1000

An Internet connection to the PC that's equipped with CODESYS may be required for license activation.

A single license allows installation on one device. Every additional device requires its own license.

x/xxxx-xxxx or x/0040-000x is a placeholder, the license is also applicable for variants of the controllers and touch panels.

The controllers 750-8212/025-001, 750-8212/025-002, 750-8212/040-001 and 750-8216/025-001 include the telecontrol licenses as delivered.

Runtime; IEC 61850 Client

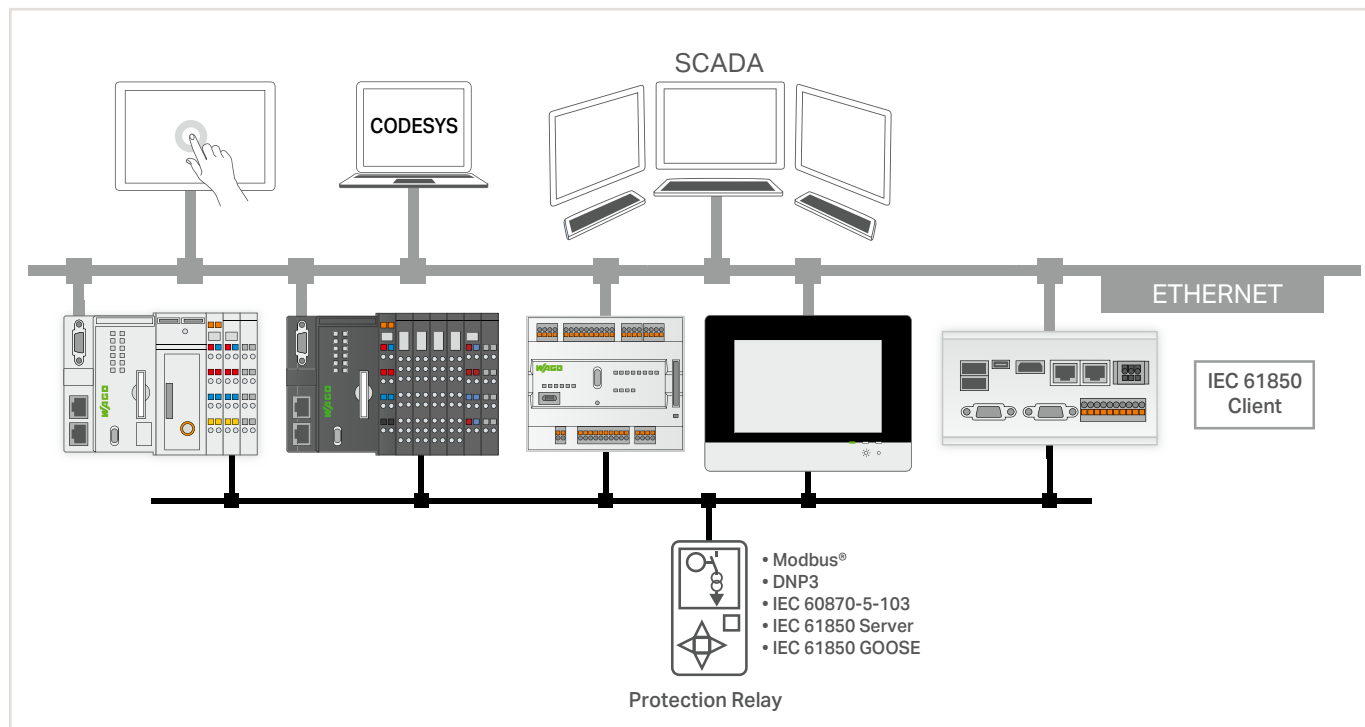

Function:

Communication according to the IEC 61850 protocol can be conveniently parameterized with the configurator. For this purpose, the CODESYS development environment is extended by the WAGO Telecontrol Package.

The configurator sets up the reading of IEC 61850 object data from protection devices, for example. If the configuration of the third-party device is available in IEC-61850 SCL exchange format, it can be read in using the configurator's import functions. Alternatively, it is also possible to read the configuration from the third-party device using the configurator's online browsing function.

With this license, the IEC 61850 Protocol can be activated on the client. This permits the creation of gateways that convert one protocol into another, e.g., allowing protection devices to be read out via IEC 61850 and data to be transmitted to the network control system via IEC 60870-5-104.

The IEC 61850 Client processes data from up to four servers with each 10 requests.

Your Benefits:

- Use the controller as a telecontrol master (client) to read data from IEC 61850 Protection Devices (servers) and process it locally in the controller.
- Create a gateway application to use this client function to forward read data to a higher-level control system or cloud. This may require additional software licenses, such as the WAGO IEC 60870 Slave, DNP 3 Slave, Sparkplug or WAGO Cloud.

Use:

The license is registered in WAGO Upload and loaded onto a device. No other installation steps are required.

Technical Data:

See Product Manual "Planning the IEC 61850 Protocol with the Telecontrol Configurator"

Item Description	
Runtime; IEC 61850 Client M	Item No.
Single License; Online Activation	2759-2243/211-1000
Compatible Controllers	
Controller PFC200; G2	750-821x/xxxx-xxxx
Controller PFC200; G2; XTR	750-821x/0040-000x
Compact Controller 100	751-9301
Item Description	
Runtime; IEC 61850 Client L	Item No.
Single License; Online Activation	2759-2246/211-1000
Compatible Devices	
Touch Panel 600 Standard Line	762-43xx/8000-002
Touch Panel 600 Advanced Line	762-53xx/8000-002
Touch Panel 600 Marine Line	762-63xx/8000-002
WAGO Edge Controller	752-8303/8000-002

Other required software	CODESYS V3.5 SP16 and higher
Delivery type	Licence certificate via email
For data sheet and additional information, see:	wago.com/2759-2246/211-1000

An Internet connection to the PC that's equipped with CODESYS may be required for license activation.

A single license allows installation on one device.

Every additional device requires its own license.

x/xxxx-xxxx or x/0040-000x is a placeholder, the license is also applicable for variants of the controllers and touch panels.

The controllers 750-8212/025-001, 750-8212/025-002, 750-8212/040-001 and 750-8216/025-001 include the telecontrol licenses as delivered.

Runtime; IEC 61850 Server

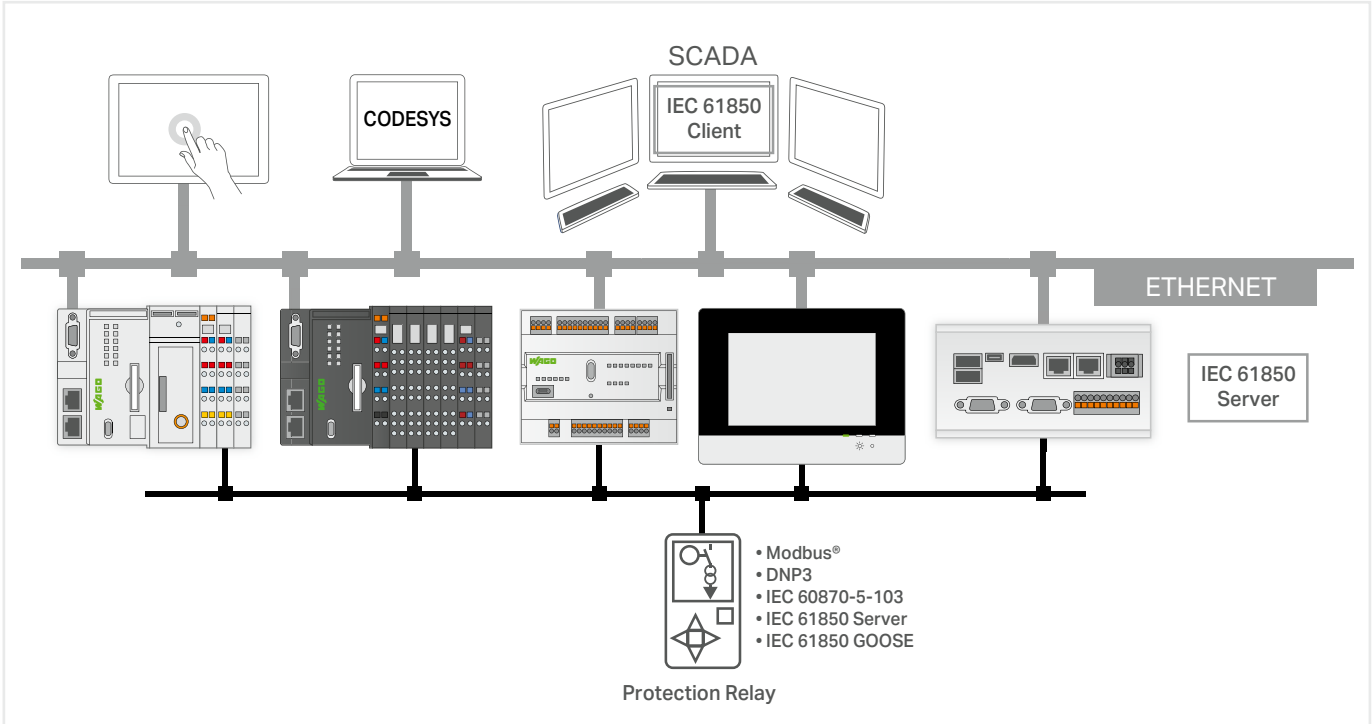

Function:

Communication according to the IEC 61850 protocol can be conveniently parameterized with the configurator. For this purpose, the CODESYS development environment is extended by the WAGO Telecontrol Package.

The user can create the IEC 61850 object structure in the configurator or alternatively import it from a file in IEC 61850 SCL format. The created configuration can be re-exported in the SCL file format so that it can be read in the remote station of an IEC 61850 client. This saves time during engineering and avoids errors. For online communication, the IEC 61850 Server supports (un)buffered reporting in MMS* format and GOOSE* Publishing.

This license enables the IEC 61850 protocol on the server side. This permits the creation of gateways that convert one protocol into another, e.g., allowing protection devices to be read out via IEC 60870-103 and data to be transmitted to the network control system via IEC 61850.

Your Benefits:

- Create a gateway application to pass data from local I/Os or data read with other protocols to a higher-level IEC 61850 management system
- Transmission of the control information of a higher-level IEC 61850 control system to protective devices via GOOSE Publishing, IEC 60870-5-103 or DNP3. This may require additional software licenses, such as the WAGO IEC 60870 Master, DNP3 Master.

Use:

The license is registered in WAGO Upload and loaded onto a device. No other installation steps are required.

Technical Data:

See the product manual "Configuring the IEC-61850 Protocol."

*MMS = Manufacturing Messaging Specification

*GOOSE = Generic Object Oriented Substation Event

Item Description	
Runtime; IEC 61850 Server	Item No.
Single License; Online Activation	2759-2240/211-1000
Compatible Devices	
Controller PFC200; G2	750-821x/xxxx-xxxx
Controller PFC200; G2; XTR	750-821x/0040-000x
Compact Controller 100	751-9301
Touch Panel 600 Standard Line	762-43xx/8000-002
Touch Panel 600 Advanced Line	762-53xx/8000-002
Touch Panel 600 Marine Line	762-63xx/8000-002
WAGO Edge Controller	752-8303/8000-002

x/xxxx-xxxx or x/0040-000x is a placeholder, the license is also applicable for variants of the controllers and touch panels.

The controllers 750-8212/025-001, 750-8212/025-002, 750-8212/040-001 and 750-8216/025-001 include the telecontrol licenses as delivered.

Other required software	CODESYS V3.5 SP16 and higher
Delivery type	Licence certificate via email
For data sheet and additional information, see:	wago.com/2759-2240/211-1000

An Internet connection to the PC that's equipped with CODESYS may be required for license activation.

A single license allows installation on one device.

Every additional device requires its own license.

Runtime; DNP3 Slave

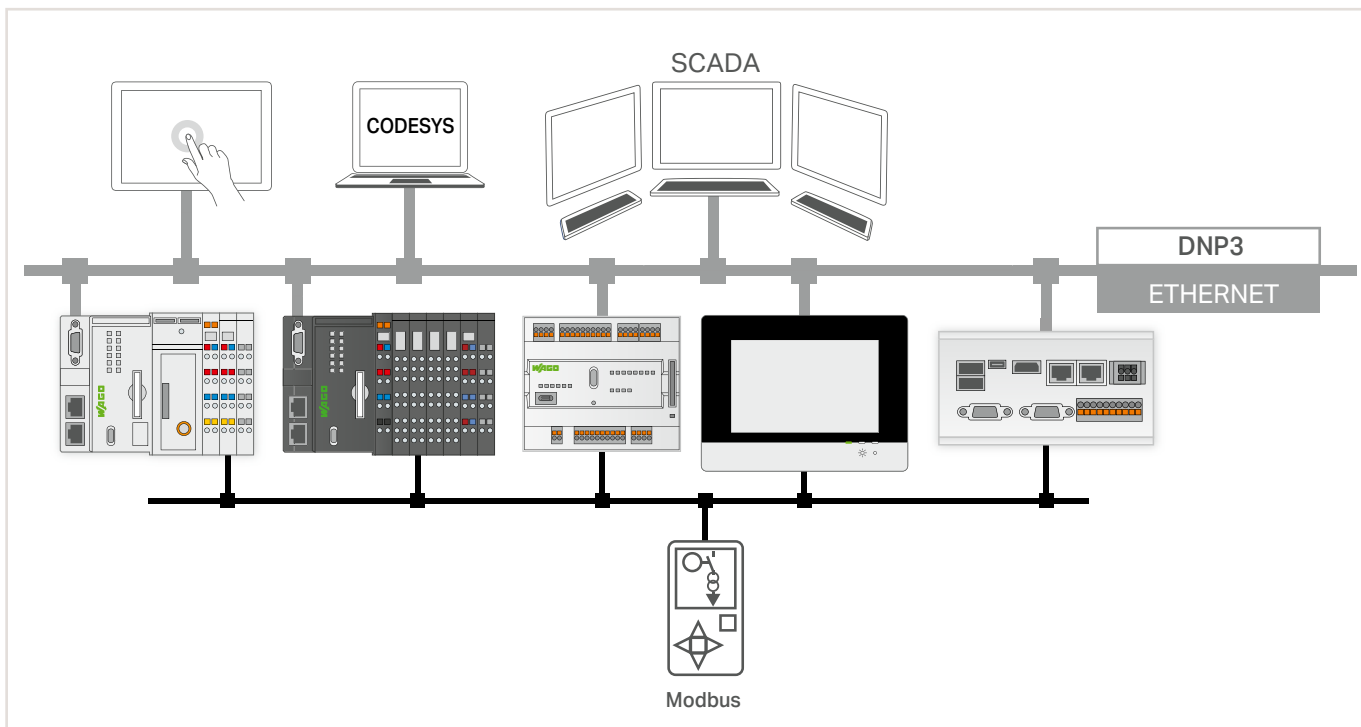

Function:

Communication according to the DNP3 protocol can be conveniently parameterized with the configurator. For this purpose, the CODESYS development environment is extended by the WAGO Telecontrol Package.

With this license, the DNP3 Protocol can be activated on the slave. The configurator fully supports the DNP3-specific functions of all WAGO telecontrollers.

The configurator sets up DNP3 objects, while configuring data exchange to the PLC application or I/O modules. The settings can be imported and exported in DNP3 XML device profile format.

WAGO's telecontrollers can work as TCP, UDP and serial DNP3 slaves.

Cyclical time synchronization of the telecontrol substation (slave) can be performed by the master according to DNP3 Device Profile 1.7.2.

In the monitoring direction, the WAGO DNP3 Slave can send digital, analog and count values to the master. Both digital and analog values can be received in the control direction. Analog values can be processed in 16-bit, 32-bit or FLOAT format. Count values can be processed in 16-bit or 32-bit format.

Your Benefits:

- Use the Controller as a telecontrol substation (slave) on an DNP3 Control System (master) via TCP, UDP or serially.
- Create a gateway application to transfer data, e.g., from Modbus® Field Devices to a DNP3 Control System.

Use:

The license is registered in WAGO Upload and loaded onto a device. No other installation steps are required.

Technical Data:

See the document "Runtime; DNP3 Slave Device Profile" on www.wago.com.

Item Description	
Runtime; DNP3 Slave	Item No.
Single License; Online Activation	2759-2290/211-1000
Compatible Devices	
Controller PFC200; G2	750-821x/xxxx-xxxx
Controller PFC200; G2; XTR	750-821x/0040-000x
Compact Controller 100	751-9301
Touch Panel 600 Standard Line	762-43xx/8000-002
Touch Panel 600 Advanced Line	762-53xx/8000-002
Touch Panel 600 Marine Line	762-63xx/8000-002
WAGO Edge Controller	752-8303/8000-002

x/xxxx-xxxx or x/0040-000x is a placeholder, the license is also applicable for variants of the controllers and touch panels.

The controllers 750-8212/025-001, 750-8212/025-002, 750-8212/040-001 and 750-8216/025-001 include the telecontrol licenses as delivered.

Other required software	CODESYS V3.5 SP16 and higher
Delivery type	Licence certificate via email
For data sheet and additional information, see:	wago.com/2759-2290/211-1000

An Internet connection to the PC that's equipped with CODESYS may be required for license activation.

A single license allows installation on one device.

Every additional device requires its own license.

Runtime; DNP3 Master

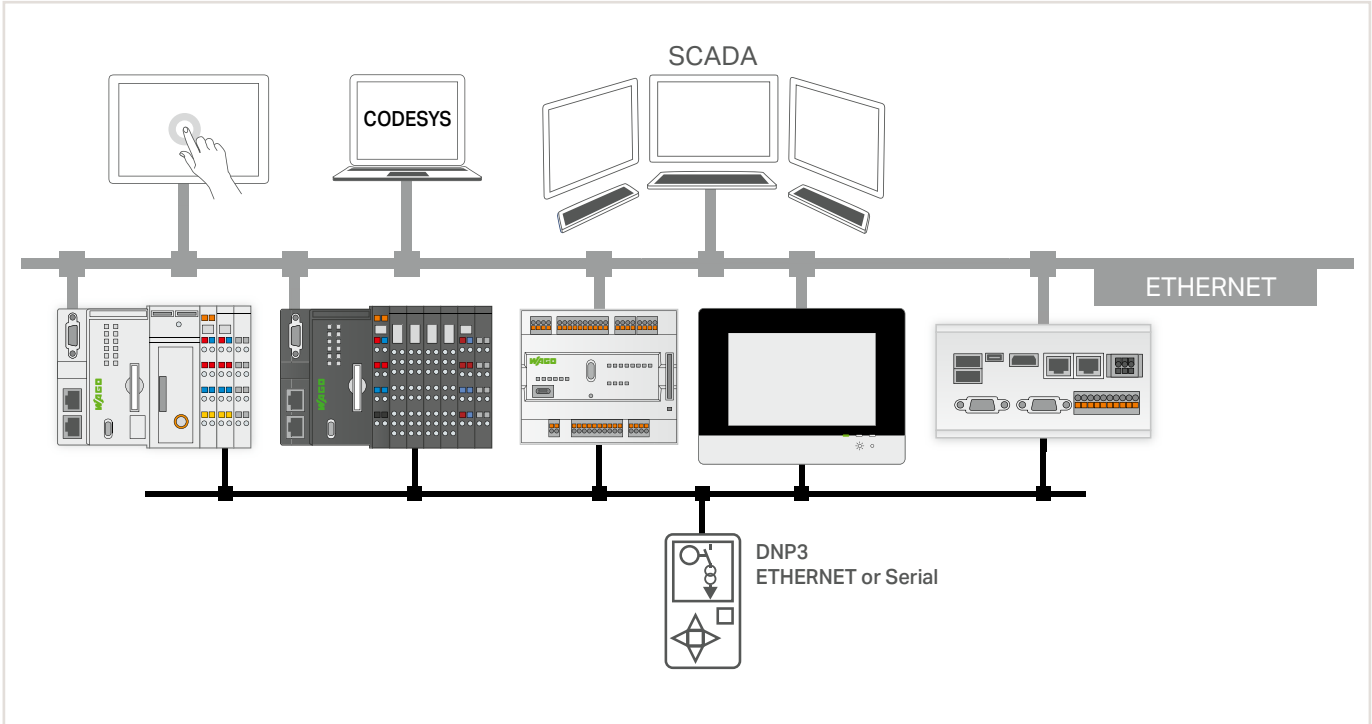

Function:

Communication according to the DNP3 protocol can be conveniently parameterized with the configurator. For this purpose, the CODESYS development environment is extended by the WAGO Telecontrol Package. With this license, the DNP3 Protocol can be activated on the master. The configurator fully supports the DNP3-specific functions of all WAGO telecontrollers. The configurator sets up DNP3 objects while configuring data exchange to the PLC application or I/O modules. As an alternative to manually configuring connections to DNP3 Slaves, it is also possible to use a description file to import the configurations in the standard DNP3 XML device profile format.

In performance class L, the master can maintain connections for up to four DNP3 Slaves, thereby working as TCP or serial DNP3 Master. Up to 10,000 events from connected DNP3 Slaves can be saved in the controller's internal RAM or on the SD card.

In the monitoring direction, the WAGO DNP3 Master L can receive digital, analog and count values from the slave. Both digital and analog values can be sent in the control direction. Analog values can be processed in 16-bit, 32-bit or FLOAT format. Count values can be processed in 16-bit or 32-bit format.

Your Benefits:

- Use of the WAGO controller as a DNP3 Master to read and process data from DNP3 Slaves (field devices) via TCP, UDP or serially.
- Create a gateway application to transfer data from DNP3 Slaves (field devices) and other protocols (e.g., IEC 60870, Modbus®).

Use:

The license is registered in WAGO Upload and loaded onto a device. No other installation steps are required.

Technical Data:

See the document "Runtime DNP3 Master Device Profile" on www.wago.com.

Item Description	
Runtime; DNP3 Master M	Item No.
Single License; Online Activation	2759-2293/211-1000
Compatible Controllers	
Controller PFC200; G2	750-821x/xxxx-xxxx
Controller PFC200; G2; XTR	750-821x/0040-000x
Compact Controller 100	751-9301
Item Description	
Runtime; DNP3 Master L	Item No.
Single License; Online Activation	2759-2296/211-1000
Compatible Devices	
Touch Panel 600 Standard Line	762-43xx/8000-002
Touch Panel 600 Advanced Line	762-53xx/8000-002
Touch Panel 600 Marine Line	762-63xx/8000-002
WAGO Edge Controller	752-8303/8000-002

Other required software	CODESYS V3.5 SP16 and higher
Delivery type	Licence certificate via email
For data sheet and additional information, see:	wago.com/2759-2293/211-1000 wago.com/2759-2296/211-1000

An Internet connection to the PC that's equipped with CODESYS may be required for license activation. A single license allows installation on one device. Every additional device requires its own license.

x/xxxx-xxxx or x/0040-000x is a placeholder, the license is also applicable for variants of the controllers and touch panels. The controllers 750-8212/025-001, 750-8212/025-002, 750-8212/040-001 and 750-8216/025-001 include the telecontrol licenses as delivered.

WAGO WebVisu App

For Mobile System Operation/Monitoring

2



With the WAGO WebVisu App, you can visualize web pages created for WAGO Controllers via CODESYS V2 or CODESYS V3. The app features both automated management and routing capabilities, allowing the website to be simply accessed via URL entry. The system or machine to be monitored can then be operated and monitored at any time on the go. You can define up to 100 controllers for direct and quick access via the URL.

The free WAGO WebVisu App is available in iOS for iPhones and iPads in the "Apple Store," and in Android for smartphones and tablets in the "Google Store."

Note: An overview of the supported WAGO Controllers, operating manuals and application notes can be found on our website.



QR Code for WebVisu App:

Simply scan the QR code with your mobile device, and you will automatically be directed to the WebVisu app in "Apple Store" or "Google Play™."



Trademarks:

Apple, the Apple logo, iPhone, iPad and iPod touch are registered trademarks of Apple Inc. registered in the USA and other countries. "App Store" is a service mark of Apple Inc.



Google Play™ is a registered trademark of Google Inc.

WAGO WebVisu App
Download: Apple Store or Google Store

System Requirements	
Operating system	iOS version 11 or later, iPadOS 11.0 or later; Android version 5.0 or later
Compatibility	iPhone; iPad and iPod touch; Android smartphones and tablets
For additional information, see:	wago.com/webvisu

WAGO I/O Field App

For Maintenance, Diagnostics, Operation and Monitoring of Installed WAGO I/O System Field Modules



I/O Field



2

The WAGO I/O Field App allows you to display product information, make settings and adjust parameters for both fieldbus modules and IO-Link hubs.

Communication is performed via the *Bluetooth®* interface of a WAGO I/O System Field Module once a Data Matrix code has been scanned to select the product.

The current measured values of a port can be displayed (temperature, voltage, current and states) and configured (e. g., operating mode, filters).

- Identification via Data Matrix codes
- Communication via *Bluetooth®*
- Download of IODDs (IODD finder)
- Access to all process and parameter data
- Simulating inputs
- Forcing outputs (DO)
- Management of datasheets, manuals etc.
- User and rights management

Trademarks:



Apple, the Apple logo, iPhone, iPad and iPod touch are registered trademarks of Apple Inc. registered in the USA and other countries. "App Store" is a service mark of Apple Inc.



Google Play™ is a registered trademark of Google Inc.

WAGO I/O Field App
Download: Apple Store or Google Store

System Requirements	
Operating system	iOS version 11.0 or later, Android version 6.0 or later
Compatibility	iPhone; iPad and iPad Air; Android smartphones and tablets
For additional information, see:	wago.com/IOField

Accessories



USB Communication Cable; USB-A; WAGO I/O System 750 Service Interface		
Length	Item No.	PU
2.5 m	750-923	1
5 m	750-923/000-001	1

RS-232 Communication Cable; RS-232 (D-Sub 9-Pole); WAGO I/O System 750 Service Interface		
Length	Item No.	PU
1 m	750-920	1

2



Operation and Monitoring

Touch Panels 600 Standard Line

- High-performance Touch Panels with resistive touchscreens
- 10.9 ... 54.7 cm (4.3 ... 21.5")
- Models include Control, Visu or Web Panels for display of CODESYS visualizations

Touch Panels 600 Advanced Line

- High-performance Touch Panels with capacitive touchscreens and glass surfaces
- 18 ... 54.7 cm (7 ... 21.5")
- Models include Control or Visu Panels

Touch Panels 600 Marine Line

- High-performance Touch Panels with resistive touchscreens
- Ideal for marine applications
- 10.9 ... 25.7 cm (4.3 ... 10.1")
- Models include Control or Visu Panels

Edge Computing

- Models include Edge Controllers or Edge Computers
- Perfect in-the-field data usage
- Easy cloud connection
- Equipped for high security

Section 4 ►

Compact Controller 100

- Maximum Performance in Minimum Space:
- Controller with a real-time Linux® operating system
 - Compact controller with I/Os in a DIN-rail-mount enclosure
 - Manufacturer-independent CODESYS V3 engineering environment

Section 5 ►►





Controllers

- Scalable controller family with various interfaces
- Microcontrollers
- Readily combines with the modules of the WAGO I/O System 750

Section 6 ►►►

Operation and Monitoring Contents

	Page
General Product Information	68
Functional Variants	69
Interfaces and Types	70
Application and Installation Instructions	72
Item Number Key	73
Standards and Rated Conditions	73
Approvals	73

	CPU	Web Browser	Modbus (TCP, UDP)	EtherNet/IP	EtherCAT	CANopen	BACnet/IP	OPC UA	Telecontrol Protocols	IoT Protocols	Hardware	Display Diagonal	Item No.												
 <p>Touch Panels 600 Standard Line</p> <p>Display: Resistive touch-screen</p>	Cortex A9	x	M/S	M/S	M	M/S	x*	x	x*	x	PIO3; Control Panel	10.9 cm (4.3")	762-4301/8000-002	74											
												14.5 cm (5.7")	762-4302/8000-002	75											
												18 cm (7.0")	762-4303/8000-002	76											
												25.7 cm (10.1")	762-4304/8000-002	77											
												39.6 cm (15.6")	762-4305/8000-002	78											
		54.7 cm (21.5")	762-4306/8000-002	79																					
		x	M	S*	M*								PIO2; Visu Panel	10.9 cm (4.3")	762-4201/8000-001	74									
														14.5 cm (5.7")	762-4202/8000-001	75									
														18 cm (7.0")	762-4203/8000-001	76									
														25.7 cm (10.1")	762-4204/8000-001	77									
														39.6 cm (15.6")	762-4205/8000-001	78									
		54.7 cm (21.5")	762-4206/8000-001	79																					
		x											PIO1; Web Panel	10.9 cm (4.3")	762-4101	74									
														14.5 cm (5.7")	762-4102	75									
														18 cm (7.0")	762-4103	76									
25.7 cm (10.1")	762-4104													77											
 <p>Touch Panels 600 Advanced Line</p> <p>Display: Capacitive touchscreen with a glass surface</p>	Cortex A9	x	M/S	M/S	M	M/S	x*	x	x*	x	PIO3; Control Panel	18 cm (7.0")	762-5303/8000-002	80											
												25.7 cm (10.1")	762-5304/8000-002	81											
												39.6 cm (15.6")	762-5305/8000-002	82											
												54.7 cm (21.5")	762-5306/8000-002	83											
		x	M	S*	M*								PIO2; Visu Panel	18 cm (7.0")	762-5203/8000-001	80									
														25.7 cm (10.1")	762-5204/8000-001	81									
														39.6 cm (15.6")	762-5205/8000-001	82									
														54.7 cm (21.5")	762-5206/8000-001	83									
														 <p>Touch Panels 600 Marine Line</p> <p>Display: Resistive touch-screen, marine version</p>	Cortex A9	x	M/S	M/S	M	M/S	x*	x	x*	x	PIO3; Control Panel
14.5 cm (5.7")	762-6302/8000-002	85																							
18 cm (7.0")	762-6303/8000-002	86																							
25.7 cm (10.1")	762-6304/8000-002	87																							
x	M	S*	M*								PIO2; Visu Panel	10.9 cm (4.3")	762-6201/8000-001			84									
												14.5 cm (5.7")	762-6202/8000-001			85									
												18 cm (7.0")	762-6203/8000-001			86									
												25.7 cm (10.1")	762-6204/8000-001			87									
 <p>Accessories</p> <p>Memory Cards; Mounting Set; Flush-Mount and Wall-Mount Housings</p>																									

M: Master; S: Slave; *requires an additional license

Operation and Monitoring

General Product Information

Operate, observe, visualize and diagnose in production and the process industry: WAGO's Touch Panels with various hardware configurations are available for small- to mid-sized control and visualization tasks. Focus on saving time with perfect usability and quickly created visualizations.

Adapted Versions

The right version is available for every application:

Devices with resistive touchscreens for standard control cabinet applications

Multi-touch devices with a glass surface for advanced requirements

Devices for marine applications

Touch Panels that Merge Aesthetics with High Performance

Underneath a contemporary design, WAGO's Touch Panels pack some of the industry's most powerful equipment, allowing you to solidify the high-tech image of your machine through high-quality visualizations from both CODESYS V3 and CODESYS V2 Engineering Software. The Web-Based Management feature of WAGO's controllers may also be operated using the stylish Web Panels. When configuring with CODESYS, visualizations are created based on modern technologies such as HTML5.

Industry 4.0/IoT

Recording, digitizing and linking data profitably – these are the core ideas of Industry 4.0. Using a dedicated library, WAGO's Control Panels become IoT controllers that send data from the field level to the cloud. Once in the cloud, this data can be aggregated and used for analysis. This capability creates tremendous added value for your company – whether it's increasing the efficiency of in-house production, implementing energy management in buildings or developing additional end-customer services. Existing systems also become IoT-ready, making them future-proof.

Quick Installation via Unique Mounting Design

WAGO's Touch Panel directly latches onto the control cabinet via mounting clips for quick and easy tool-free installation. Thanks to custom-developed clamps, the front of the display meets lofty IP65 protection standards. This design flexibility makes the display extremely versatile and suitable for a wide variety of applications. Furthermore, the VESA mount allows installation on a swivel arm or stand outside of the control cabinet.

Easy to Use – Directly on the Display

All WAGO's Touch Panels have status LEDs that indicate operating status and provide operational feedback. A customized configuration interface is available for customizing and commissioning the Touch Panels. All important settings are made here via Web-Based Management. For quick and easy custom settings, the display brightness can also be manually adjusted via front-mount button.

Energy-Saving Sensors Ensure Safety

WAGO's Touch Panels have an integrated proximity sensor, allowing the visualization to be automatically re-displayed from the energy-saving screensaver. An integrated sensor simultaneously detects ambient lighting levels for automatic brightness control.

Integrated PLC

In the "Control Panel" function, the devices offer an integrated PLC functionality, which is configured via CODESYS. This makes them programmable in five standardized languages. In addition to pure programming, CODESYS is also used for offline simulation, fieldbus configuration, recipe management and much more.

Scaled Visualization Functions

Displaying a visualization in a Web browser makes flexible options available. In addition to the Web Panels, visualizations can be displayed on nearly any device with a browser, including smartphones and tablets by using the WebVisu app.

When greater performance is required, devices are used as Visu Panels. In the process, all operating functions are evaluated within the device without a delay and can affect the visualization directly. Data to be displayed is read in via standardized bus systems (e.g., Modbus TCP).

Open-Source Software and Linux®

We unite what belongs together: High-performance WAGO Hardware and the future-proof Linux® Operating System. For complex tasks, you can choose between programming in IEC 61131 or directly under Linux®. WAGO's "Embedded Linux" Controllers impress with base images that are expandable via open-source packages. As a "Gold Member" of the Open Source Automation Development Lab (OSADL), WAGO supports both financing and further development of Linux® in the industrial sector. The controller firmware itself is available as a "Board Support Package" (BSP).

If you are interested, simply contact our AUTOMATION technical support.

Benefits:

- An aesthetic design meets high performance
- Scaled portfolio in design and functionality
- Easy to use – directly on the display
- Quick installation via unique mounting design
- IoT-ready

Operation and Monitoring Functional Variants

Web Panels

The operating and display devices in the "Web Panel" software configuration are provided with a Web browser for accessing and displaying controllers with integrated Web visualization via standard Web protocols. Depending on the type of execution, Web visualizations that are created with CODESYS V3 and/or with CODESYS V2 can be displayed. Web visualizations have the advantage of being displayed not only on special Visu Panels, but also on standard commercial mobile devices.

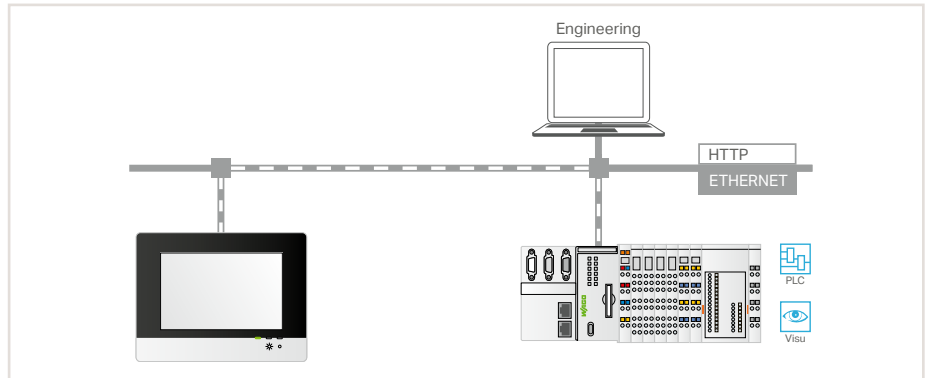

Visu Panels

Operating and display devices in the "Visu Panel" software configuration are suitable for displaying a visualization generated with CODESYS V3 and obtaining the data referenced in it from any field devices via TCP, e.g., from PFC200 Controllers. In contrast to Web Panels, the computing power required here is divided between two devices, so the computing necessary for displaying the visualization is basically performed by the Visu Panel, off-loading the controller. The Visu Panel can also provide a Web visualization via the integrated Webserver.

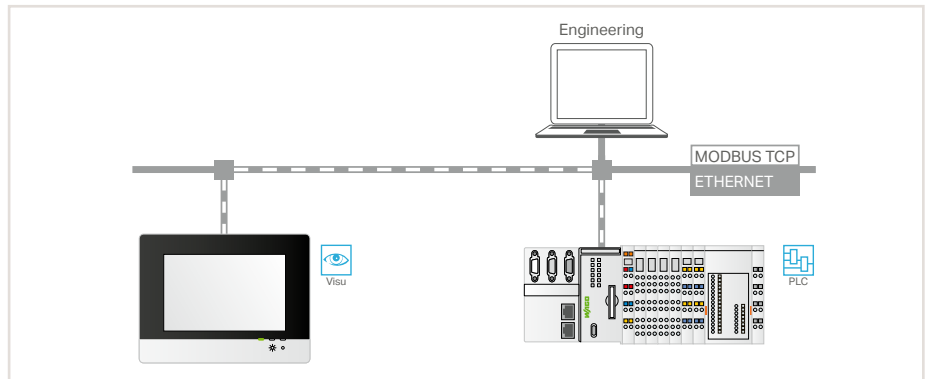

Control Panels

Operating and display devices in the "Control Panel" software configuration allow control and visualization to be performed simultaneously, providing a very compact automation solution.

WAGO's Control Panels handle all the usual tasks that would otherwise be performed by a separate controller, including establishing a connection to the cloud, for example.

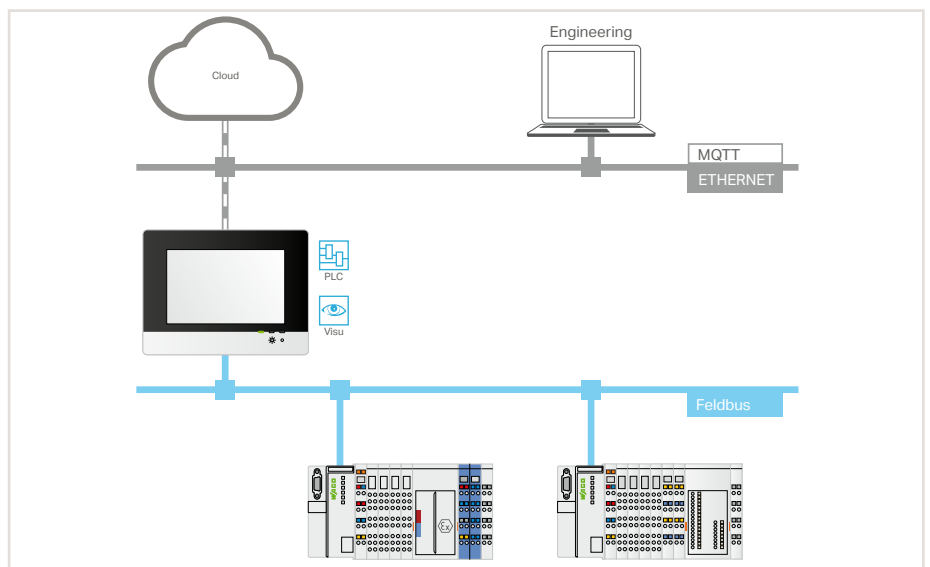

Operation and Monitoring Interfaces and Types

Touch Panels Standard Line

By default, WAGO's Touch Panels are equipped with resistive touchscreens. In addition, they have two capacitive buttons (A and B) for on-device brightness settings. A 3-color LED (D) indicates the device status. An integrated motion and brightness sensor (C) detects when a person is approaching and automatically turns off the screensaver. In addition, it can be used for automatic brightness change (day/night).

Available sizes:

- 10.9 cm (4.3")
- 14.5 cm (5.7")
- 18 cm (7.0")
- 25.7 cm (10.1")
- 39.6 cm (15.6")
- 54.7 cm (21.5")

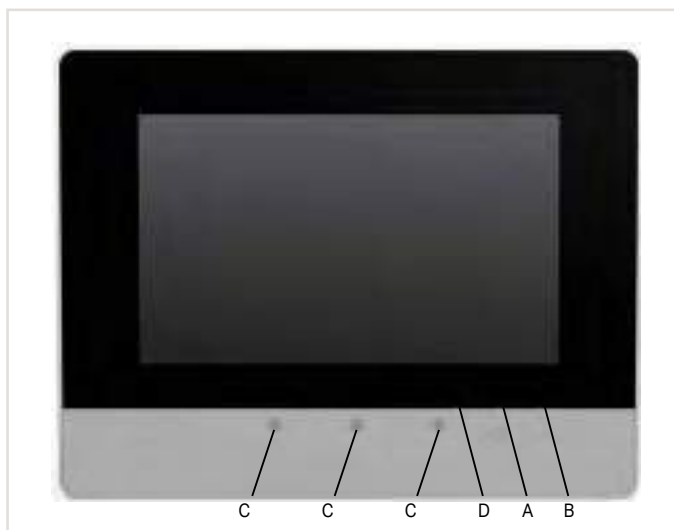

Touch Panels Advanced Line

In contrast to the standard version, these devices are equipped with a capacitive touchscreen and a glass surface. This allows gesture recognition, e.g., swiping for turning pages or enlarging. In addition, the glass front features greater mechanical and chemical resistance. Operation while wearing gloves is also possible.

Available sizes:

- 18 cm (7.0")
- 25.7 cm (10.1")
- 39.6 cm (15.6")
- 54.7 cm (21.5")

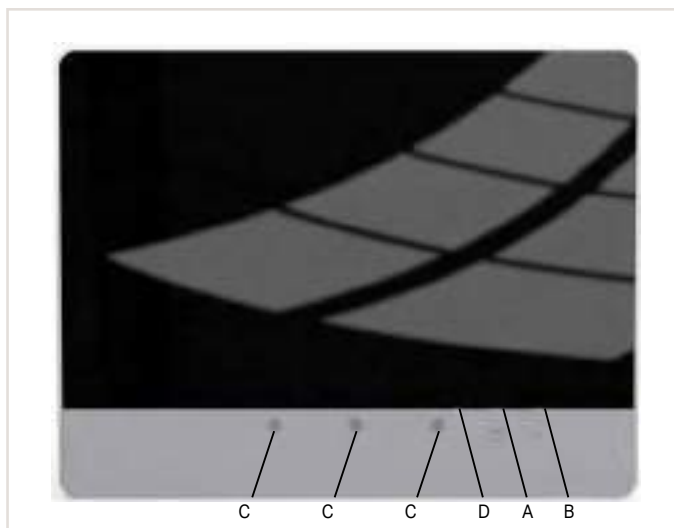

Touch Panels Marine Line

In this version, WAGO's Touch Panels are ideal for shipbuilding applications and have special marine approvals. The matte black surface prevents disturbing reflections.

Available sizes:

- 10.9 cm (4.3")
- 14.5 cm (5.7")
- 18 cm (7.0")
- 25.7 cm (10.1")



Operation and Monitoring Interfaces and Types

Hardware Configuration PIO1

Besides the power supply connection, devices with the PIO1 hardware configuration provide:

- 2 x ETHERNET port for connecting to field devices and the engineering tool
- 2 x USB port for optional connection of a USB stick, mouse or keyboard

Devices of this type are primarily used as Web Panels.

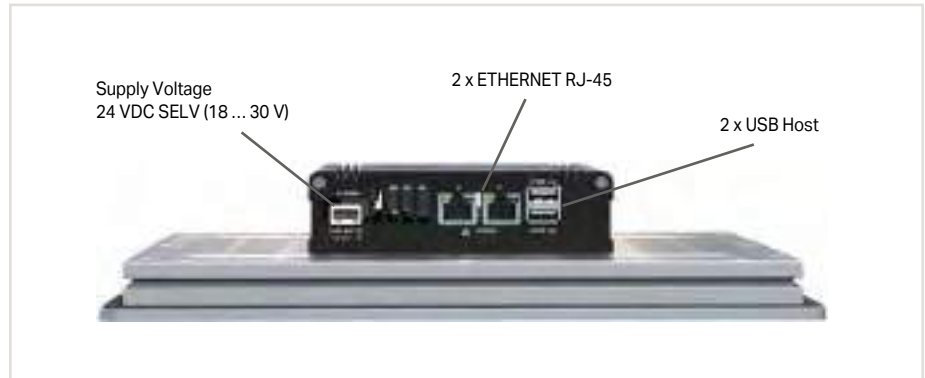

Hardware Configuration PIO2

The PIO2 hardware configuration contains the same connections as PIO1 hardware. In addition, the devices are equipped with an audio interface for connecting headphones or a loudspeaker. Devices of this type are primarily used as Visu Panels.

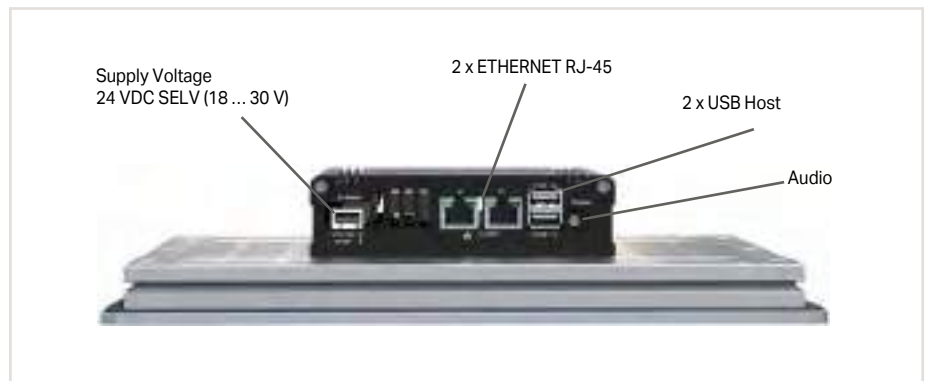

Hardware Configuration PIO3

Devices of this type are primarily used as Control Panels. Besides the interfaces of the PIO2 configuration, they also have the following interfaces:

- 1 x CAN for controlling field devices
- 1 x RS-232/485 interface for controlling field devices with a serial interface
- 4 x digital input/output for reading/triggering digital signals

In addition, this hardware configuration has a rapid, power-failure-proof storage component that can back up retain variables of the controller without additional UPS features.

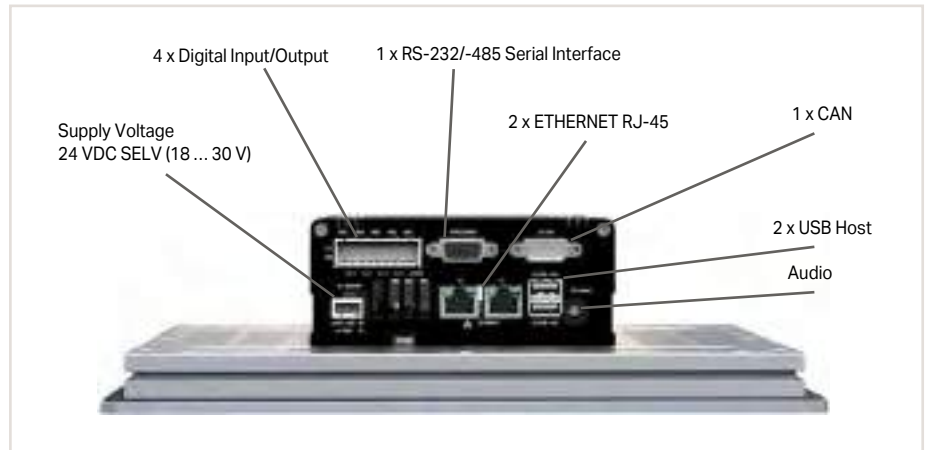

Common Control Elements

The following control elements are provided on the side of all devices:

- Run/Stop switch (only relevant for Control Panels)
- Service Switch
- 5 x LED for signaling:
 - General device states
 - Special states of the PLC runtime environment
 - States of the fieldbus connections
- 1 x microSD card for data exchange



Operation and Monitoring

Application and Installation Instructions



Two brightness adjustment keys are located directly on the front of the device, along with three diagnostics LEDs.

Mounting

WAGO's Touch Panel directly latches onto the control cabinet via mounting spring clips for quick and easy tool-free installation. IP65 levels of protection can be achieved for the front of the display via additional clamping screws. This design flexibility makes the display extremely versatile and suitable for a wide variety of applications.



The VESA mount (VESA 75 standard, 75 mm hole spacing) allows universal mounting accessories to be conveniently used outside of the control cabinet.

Operation and Monitoring

Item Number Key

Explanation of an item number key's components

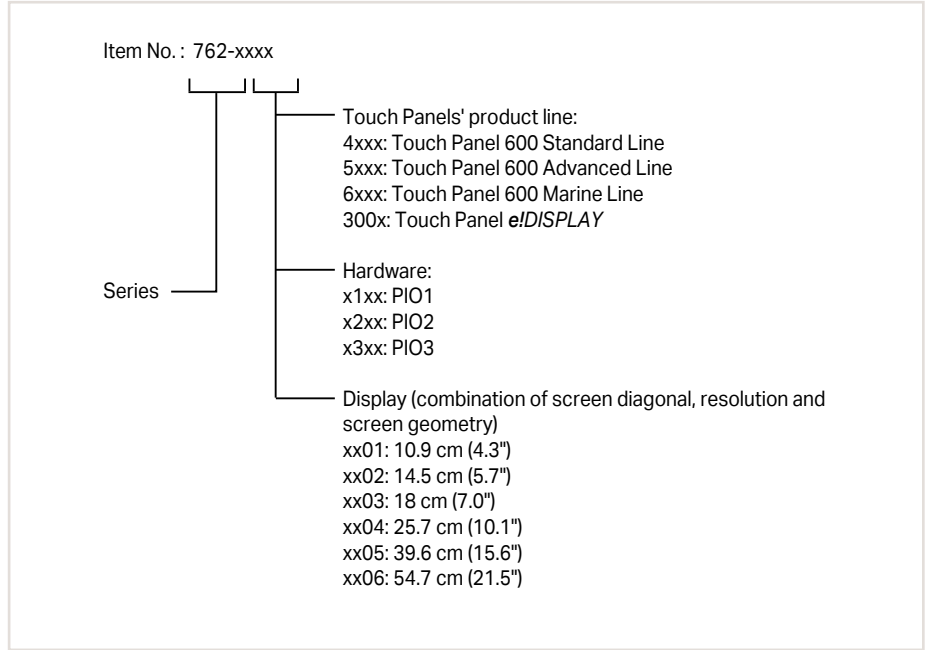

3

Standards and Rated Conditions

General Technical Data	
Operating system	Real-time Linux® (with RT-Preempt patch)
Controls	Resistive touch panel; 2 capacitive keys; proximity sensor
Supply voltage	24 VDC, SELV (-25 ... +30 %) with reverse voltage protection
Indicators	Diagnostic indication (LED)
Surrounding air temperature (operation)	-20 ... +55 °C
Surrounding air temperature (storage)	-20 ... +80 °C
Relative humidity	10 ... 90 %; non-condensing
Protection type	IP65 (front side); IP20 (rear side)

Approvals

For approvals overview (item comparison), see Section 14 (Technical Section) or visit www.wago.com.



Touch Panels ▶ Standard Line ▶ 10.9 cm (4.3 inches)



Version	Hardware configuration PIO3; Control Panel	Hardware configuration PIO2; Visu Panel	Hardware configuration PIO1; Web Panel
Item no.	762-4301/8000-002	762-4201/8000-001	762-4101
Order Text	TP600; 4.3; 480x272; PIO3; CP	TP600; 4.3; 480x272; PIO2; VP	TP600; 4.3; 480x272; PIO1; WP
Technical data			
Display	Resistive touchscreen		
Display diagonal	10.9 cm (4.3 inches)		
Contrast ratio	600:1		
Aspect	16:9		
Display colors	16 million colors		
Graphics resolution	(480 x 272) px		
Viewing angle (horizontal/vertical)	80° / 80°		
Brightness	500 cd/m ²		
Controls	Resistive touch panel; 2 capacitive keys; proximity sensor		
Communication	Web browser; Web browser (HTML5); Modbus TCP master/slave; Modbus (UDP); Modbus (RTU); ETHERNET; EtherNet/IP™ Adapter (slave); EtherNet/IP™ Scanner; CANopen; EtherCAT® Master; OPC UA Server/Client; OPC UA Pub/Sub (can be installed later); MQTT; RS-232 serial interface; RS-485 interface; BACnet/IP, requires an additional license ; Telecontrol protocols, requires an additional license ; MicroBrowser (Visualization of CODESYS V2.3), requires an additional license	EtherNet/IP™ adapter (slave), library for e!RUNTIME (prerequisite: e!RUNTIME PLC 600 license); Modbus TCP master/slave (prerequisite: e!RUNTIME PLC 600 license); EtherCAT master, requires an additional license (prerequisite: e!RUNTIME PLC 600 license); BACnet/IP, requires an additional license (prerequisite: e!RUNTIME PLC 600 license)	Web browser (HTML5)
ETHERNET protocols	DHCP; DNS; FTP; FTPS; HTTP; HTTPS; SSH		
Programming environment	CODESYS V3.5, from firmware release 24; e!COCKPIT (based on CODESYS V3), up to firmware release 22	e!COCKPIT (based on CODESYS V3)	-
Operating system	Real-time Linux (with RT-Preempt patch)		
Processor	ARM® Cortex® A9 Quadcore 1.0 GHz		
Main memory (RAM)/internal memory (flash)	2 GB / 4 GB		
Program memory/data memory/non-volatile memory (software)	32 MB / 128 MB / 128 KB	32 MB / 128 MB / -	-
Type of memory card	microSD (max. 2 GB); microSDHC (max. 32 GB)		
Interfaces (USB)	2 x USB host 2.0 (type A)		
Onboard I/Os	Audio; 4 x DIO, configurable	Audio	-
Dimensions W x H x D	(155 x 135 x 78) mm	(155 x 135 x 58) mm	
Panel cutout (W x H)	(140 x 120) mm		
Mounting type	Clamping elements (included) or VESA mount (4 x M4x8)		
Supply voltage	24 VSELV DC (18 ... 31.2 V); with reverse voltage protection		
Input current (typ.)	310 mA, without USB load; 575 mA, with USB load	290 mA, without USB load; 555 mA, with USB load	
Operating power	6.0 W, without USB load; 11.5 W, with USB load	5.8 W, without USB load; 11.3 W, with USB load	
Ambient temperature (operation)	-20 ... +55 °C (when mounted vertically; -20 ... +50 °C, other mounting positions)		
Approvals	CE; Marine; OrdLoc		
For data sheet and additional information, see:	wago.com/762-4301/8000-002	wago.com/762-4201/8000-001	wago.com/762-4101
Product Expansions	Item no.	Item no.	Item no.
Runtime; BACnet; 600; Single License; Online activation	2759-286/211-1000	-	-
Runtime; MicroBrowser; Single License; Online activation	2759-230/211-1000	2759-230/211-1000	2759-230/211-1000
Accessories	Item no.	Item no.	Item no.
Memory Card SD Micro; 2 GB	758-879/000-3102	758-879/000-3102	758-879/000-3102
Memory Card SD Micro; pSLC-NAND; 8 GB	758-879/000-3108	758-879/000-3108	758-879/000-3108

Touch Panels ▶ Standard Line ▶ 14.5 cm (5.7 inches)



Version	Hardware configuration PIO3; Control Panel	Hardware configuration PIO2; Visu Panel	Hardware configuration PIO1; Web Panel
Item no.	762-4302/8000-002	762-4202/8000-001	762-4102
Order Text	TP600; 5.7; 640x480; PIO3; CP	TP600; 5.7; 640x480; PIO2; VP	TP600; 5.7; 640x480; PIO1; WP
Technical data			
Display	Resistive touchscreen		
Display diagonal	14.5 cm (5.7 inches)		
Contrast ratio	300:1		
Aspect	4:3		
Display colors	262,000 colors		
Graphics resolution	(640 x 480) px		
Viewing angle (horizontal/vertical)	80° / 80°		
Brightness	630 cd/m ²		
Controls	Resistive touch panel; 2 capacitive keys; proximity sensor		
Communication	Web browser; Web browser (HTML5); Modbus TCP master/slave; Modbus (UDP); Modbus (RTU); ETHERNET; EtherNet/IP™ Adapter (slave); EtherNet/IP™ Scanner; CANopen; EtherCAT® Master; OPC UA Server/Client; OPC UA Pub/Sub (can be installed later); MQTT; RS-232 serial interface; RS-485 interface; BACnet/IP, requires an additional license ; Telecontrol protocols, requires an additional license ; MicroBrowser (Visualization of CODESYS V2.3), requires an additional license	EtherNet/IP™ adapter (slave), library for e!RUNTIME (prerequisite: e!RUNTIME PLC 600 license); Modbus TCP master/slave (prerequisite: e!RUNTIME PLC 600 license); EtherCAT master, requires an additional license (prerequisite: e!RUNTIME PLC 600 license); BACnet/IP, requires an additional license (prerequisite: e!RUNTIME PLC 600 license)	Web browser (HTML5)
ETHERNET protocols	DHCP; DNS; FTP; FTPS; HTTP; HTTPS; SSH		
Programming environment	CODESYS V3.5, from firmware release 24; e!COCKPIT (based on CODESYS V3), up to firmware release 22	e!COCKPIT (based on CODESYS V3)	-
Operating system	Real-time Linux (with RT-Preempt patch)		
Processor	ARM® Cortex® A9 Quadcore 1.0 GHz		
Main memory (RAM)/internal memory (flash)	2 GB / 4 GB		
Program memory/data memory/non-volatile memory (software)	32 MB / 128 MB / 128 KB	32 MB / 128 MB / -	-
Type of memory card	microSD (max. 2 GB); microSDHC (max. 32 GB)		
Interfaces (USB)	2 x USB host 2.0 (type A)		
Onboard I/Os	Audio; 4 x DIO, configurable	Audio	-
Dimensions W x H x D	(172 x 163 x 78) mm	(172 x 163 x 58) mm	
Panel cutout (W x H)	(157 x 148) mm		
Mounting type	Clamping elements (included) or VESA mount (4 x M4x8)		
Supply voltage	24 VSELV DC (18 ... 31.2 V); with reverse voltage protection		
Input current (typ.)	360 mA, without USB load; 640 mA, with USB load	340 mA, without USB load; 620 mA, with USB load	
Operating power	7.0 W, without USB load; 12.0 W, with USB load	6.8 W, without USB load; 11.8 W, with USB load	
Ambient temperature (operation)	-20 ... +55 °C (when mounted vertically; -20 ... +50 °C, other mounting positions)		
Approvals	CE, Marine, OrdLoc		
For data sheet and additional information, see:	wago.com/762-4302/8000-002	wago.com/762-4202/8000-001	wago.com/762-4102
Product Expansions	Item no.	Item no.	Item no.
Runtime; BACnet; 600; Single License; Online activation	2759-286/211-1000	-	-
Runtime; MicroBrowser; Single License; Online activation	2759-230/211-1000	2759-230/211-1000	2759-230/211-1000
Accessories	Item no.	Item no.	Item no.
Memory Card SD Micro; 2 GB	758-879/000-3102	758-879/000-3102	758-879/000-3102
Memory Card SD Micro; pSLC-NAND; 8 GB	758-879/000-3108	758-879/000-3108	758-879/000-3108

Touch Panels ▶ Standard Line ▶ 17.8 cm (7 inches)



Version	Hardware configuration PIO3; Control Panel	Hardware configuration PIO2; Visu Panel	Hardware configuration PIO1; Web Panel
Item no.	762-4303/8000-002	762-4203/8000-001	762-4103
Order Text	TP600; 7.0; 800x480; PIO3; CP	TP600; 7.0; 800x480; PIO2; VP	TP600; 7.0; 800x480; PIO1; WP
Technical data			
Display	Resistive touchscreen		
Display diagonal	17.8 cm (7 inches)		
Contrast ratio	800:1		
Aspect	16:9		
Display colors	16 million colors		
Graphics resolution	(800 x 480) px		
Viewing angle (horizontal/vertical)	89° / 89°		
Brightness	450 cd/m ²		
Controls	Resistive touch panel; 2 capacitive keys; proximity sensor		
Communication	Web browser; Web browser (HTML5); Modbus TCP master/slave; Modbus (UDP); Modbus (RTU); ETHERNET; EtherNet/IP™ Adapter (slave); EtherNet/IP™ Scanner; CANopen; EtherCAT® Master; OPC UA Server/Client; OPC UA Pub/Sub (can be installed later); MQTT; RS-232 serial interface; RS-485 interface; BACnet/IP, requires an additional license ; Telecontrol protocols, requires an additional license ; MicroBrowser (Visualization of CODESYS V2.3), requires an additional license	EtherNet/IP™ adapter (slave), library for e!RUNTIME (prerequisite: e!RUNTIME PLC 600 license); Modbus TCP master/slave (prerequisite: e!RUNTIME PLC 600 license); EtherCAT master, requires an additional license (prerequisite: e!RUNTIME PLC 600 license); BACnet/IP, requires an additional license (prerequisite: e!RUNTIME PLC 600 license)	Web browser (HTML5)
ETHERNET protocols	DHCP; DNS; FTP; FTPS; HTTP; HTTPS; SSH		
Programming environment	CODESYS V3.5, from firmware release 24; e!COCKPIT (based on CODESYS V3), up to firmware release 22	e!COCKPIT (based on CODESYS V3)	-
Operating system	Real-time Linux (with RT-Preempt patch)		
Processor	ARM® Cortex® A9 Quadcore 1.0 GHz		
Main memory (RAM)/internal memory (flash)	2 GB / 4 GB		
Program memory/data memory/non-volatile memory (software)	32 MB / 128 MB / 128 KB	32 MB / 128 MB / -	-
Type of memory card	microSD (max. 2 GB); microSDHC (max. 32 GB)		
Interfaces (USB)	2 x USB host 2.0 (type A)		
Onboard I/Os	Audio; 4 x DIO, configurable	Audio	-
Dimensions W x H x D	(213 x 167 x 78) mm		
Panel cutout (W x H)	(198 x 152) mm		
Mounting type	Clamping elements (included) or VESA mount (4 x M4x8)		
Supply voltage	24 VSELV DC (18 ... 31.2 V); with reverse voltage protection		
Input current (typ.)	460 mA, without USB load; 760 mA, with USB load	420 mA, without USB load; 720 mA, with USB load	
Operating power	8.8 W, without USB load; 13.9 W, with USB load	8.6 W, without USB load; 13.7 W, with USB load	
Ambient temperature (operation)	-20 ... +55 °C (when mounted vertically; -20 ... +50 °C, other mounting positions)		
Approvals	CE; Marine; OrdLoc		
For data sheet and additional information, see:	wago.com/762-4303/8000-002	wago.com/762-4203/8000-001	wago.com/762-4103
Product Expansions	Item no.	Item no.	Item no.
Runtime; BACnet; 600; Single License; Online activation	2759-286/211-1000	-	-
Runtime; MicroBrowser; Single License; Online activation	2759-230/211-1000	2759-230/211-1000	2759-230/211-1000
Accessories	Item no.	Item no.	Item no.
Memory Card SD Micro; 2 GB	758-879/000-3102	758-879/000-3102	758-879/000-3102
Memory Card SD Micro; pSLC-NAND; 8 GB	758-879/000-3108	758-879/000-3108	758-879/000-3108

Touch Panels ▶ Standard Line ▶ 25.7 cm (10.1 inches)



Version	Hardware configuration PIO3; Control Panel	Hardware configuration PIO2; Visu Panel	Hardware configuration PIO1; Web Panel
Item no.	762-4304/8000-002	762-4204/8000-001	762-4104
Order Text	TP600; 10.1; 1280x800; PIO3; CP	TP600; 10.1; 1280x800; PIO2; VP	TP600; 10.1; 1280x800; PIO1; WP
Technical data			
Display	Resistive touchscreen		
Display diagonal	25.7 cm (10.1 inches)		
Contrast ratio	800:1		
Aspect	16:9		
Display colors	16 million colors		
Graphics resolution	(1280 x 800) px		
Viewing angle (horizontal/vertical)	85° / 85°		
Brightness	800 cd/m ²		
Controls	Resistive touch panel; 2 capacitive keys; proximity sensor		
Communication	Web browser; Web browser (HTML5); Modbus TCP master/slave; Modbus (UDP); Modbus (RTU); ETHERNET; EtherNet/IP™ Adapter (slave); EtherNet/IP™ Scanner; CANopen; EtherCAT® Master; OPC UA Server/Client; OPC UA Pub/Sub (can be installed later); MQTT; RS-232 serial interface; RS-485 interface; BACnet/IP, requires an additional license ; Telecontrol protocols, requires an additional license ; MicroBrowser (Visualization of CODESYS V2.3), requires an additional license	EtherNet/IP™ adapter (slave), library for e!RUNTIME (prerequisite: e!RUNTIME PLC 600 license); Modbus TCP master/slave (prerequisite: e!RUNTIME PLC 600 license); EtherCAT master, requires an additional license (prerequisite: e!RUNTIME PLC 600 license); BACnet/IP, requires an additional license (prerequisite: e!RUNTIME PLC 600 license)	Web browser (HTML5)
ETHERNET protocols	DHCP; DNS; FTP; FTPS; HTTP; HTTPS; SSH		
Programming environment	CODESYS V3.5, from firmware release 24; e!COCKPIT (based on CODESYS V3), up to firmware release 22	e!COCKPIT (based on CODESYS V3)	-
Operating system	Real-time Linux (with RT-Preempt patch)		
Processor	ARM® Cortex® A9 Quadcore 1.0 GHz		
Main memory (RAM)/internal memory (flash)	2 GB / 4 GB		
Program memory/data memory/non-volatile memory (software)	32 MB / 128 MB / 128 KB	32 MB / 128 MB / -	-
Type of memory card	microSD (max. 2 GB); microSDHC (max. 32 GB)		
Interfaces (USB)	2 x USB host 2.0 (type A)		
Onboard I/Os	Audio; 4 x DIO, configurable	Audio	-
Dimensions W x H x D	(293 x 223 x 78) mm	(293 x 223 x 58) mm	
Panel cutout (W x H)	(278 x 208) mm		
Mounting type	Clamping elements (included) or VESA mount (4 x M4x8)		
Supply voltage	24 VSELV DC (18 ... 31.2 V); with reverse voltage protection		
Input current (typ.)	640 mA, without USB load; 940 mA, with USB load	620 mA, without USB load; 920 mA, with USB load	
Operating power	11.8 W, without USB load; 17.0 W, with USB load	11.6 W, without USB load; 16.8 W, with USB load	
Ambient temperature (operation)	-20 ... +55 °C (when mounted vertically; -20 ... +50 °C, other mounting positions)		
Approvals	CE, Marine, OrdLoc		
For data sheet and additional information, see:	wago.com/762-4304/8000-002	wago.com/762-4204/8000-001	wago.com/762-4104
Product Expansions	Item no.	Item no.	Item no.
Runtime; BACnet; 600; Single License; Online activation	2759-286/211-1000	-	-
Runtime; MicroBrowser; Single License; Online activation	2759-230/211-1000	2759-230/211-1000	2759-230/211-1000
Accessories	Item no.	Item no.	Item no.
Memory Card SD Micro; 2 GB	758-879/000-3102	758-879/000-3102	758-879/000-3102
Memory Card SD Micro; pSLC-NAND; 8 GB	758-879/000-3108	758-879/000-3108	758-879/000-3108

Touch Panels ▶ Standard Line ▶ 39.6 cm (15.6 inches)



Version	Hardware configuration PIO3; Control Panel	Hardware configuration PIO2; Visu Panel
Item no.	762-4305/8000-002	762-4205/8000-001
Order Text	TP600; 15.6; 1920x1080; PIO3; CP	TP600; 15.6; 1920x1080; PIO2; VP
Technical data		
Display	Resistive touchscreen	
Display diagonal	39.6 cm (15.6 inches)	
Contrast ratio	800:1	
Display colors	16.7 million colors	
Graphics resolution	(1920 x 1080) px	
Viewing angle (horizontal/vertical)	85° / 85°	
Brightness	500 cd/m ²	
Controls	Resistive touch panel; 2 capacitive keys; proximity sensor	
Communication	Web browser; Web browser (HTML5); Modbus TCP master/slave; Modbus (UDP); Modbus (RTU); ETHERNET; EtherNet/IP™ Adapter (slave); EtherNet/IP™ Scanner; CANopen; EtherCAT® Master; OPC UA Server/Client; OPC UA Pub/Sub (can be installed later); MQTT; RS-232 serial interface; RS-485 interface; BACnet/IP, requires an additional license ; Telecontrol protocols, requires an additional license ; MicroBrowser (Visualization of CODESYS V2.3), requires an additional license	EtherNet/IP™ adapter (slave), library for e!RUNTIME (prerequisite: e!RUNTIME PLC 600 license); Modbus TCP master/slave (prerequisite: e!RUNTIME PLC 600 license); EtherCAT master, requires an additional license (prerequisite: e!RUNTIME PLC 600 license); BACnet/IP, requires an additional license (prerequisite: e!RUNTIME PLC 600 license)
ETHERNET protocols	DHCP; DNS; FTP; FTPS; HTTP; HTTPS; SSH	
Programming environment	CODESYS V3.5, from firmware release 24; e!COCKPIT (based on CODESYS V3), up to firmware release 22	e!COCKPIT (based on CODESYS V3)
Operating system	Real-time Linux (with RT-Preempt patch)	
Processor	ARM® Cortex® A9 Quadcore 1.0 GHz	
Main memory (RAM)/internal memory (flash)	2 GB / 4 GB	
Program memory/data memory/non-volatile memory (software)	32 MB / 128 MB / 128 KB	32 MB / 128 MB / -
Type of memory card	microSD (max. 2 GB); microSDHC (max. 32 GB)	
Interfaces (USB)	2 x USB host 2.0 (type A)	
Onboard I/Os	Audio; 4 x DIO, configurable	Audio
Dimensions W x H x D	(420 x 283 x 78) mm	(420 x 283 x 58) mm
Panel cutout (W x H)	(406 x 268) mm	
Mounting type	Clamping elements (included)	
Supply voltage	24 VSELV DC (18 ... 31.2 V); with reverse voltage protection	
Input current (typ.)	450 mA; without USB load; 679 mA; with USB load	430 mA; without USB load; 658 mA; with USB load
Operating power	10.8 W, without USB load; 16.3 W, with USB load	10.3 W, without USB load; 15.8 W, with USB load
Ambient temperature (operation)	-20 ... +55 °C (when mounted vertically; -20 ... +50 °C, other mounting positions)	
Approvals	CE; OrdLoc	
For data sheet and additional information, see:	wago.com/762-4305/8000-002	wago.com/762-4205/8000-001
Product Expansions	Item no.	Item no.
Runtime; BACnet; 600; Single License; Online activation	2759-286/211-1000	-
Runtime; MicroBrowser; Single License; Online activation	2759-230/211-1000	2759-230/211-1000
Runtime; EtherCAT Master; 600; Single License; Online activation	-	2759-266/211-1000
Runtime; IEC 61131 runtime environment; 600; Single License; Online activation	-	2759-216/211-1000
Accessories	Item no.	Item no.
Memory Card SD Micro; 2 GB	758-879/000-3102	758-879/000-3102
Memory Card SD Micro; pSLC-NAND; 8 GB	758-879/000-3108	758-879/000-3108

Touch Panels ▶ Standard Line ▶ 54.7 cm (21.5 inches)



Version	Hardware configuration PIO3; Control Panel	Hardware configuration PIO2; Visu Panel
Item no.	762-4306/8000-002	762-4206/8000-001
Order Text	TP600; 21.5; 1920x1080; PIO3; CP	TP600; 21.5; 1920x1080; PIO2; VP
Technical data		
Display	Resistive touchscreen	
Display diagonal	54.7 cm (21.5 inches)	
Contrast ratio	1000:1	
Display colors	16.7 million colors	
Graphics resolution	(1920 x 1080) px	
Viewing angle (horizontal/vertical)	89° / 89°	
Brightness	350 cd/m ²	
Controls	Resistive touch panel; 2 capacitive keys; proximity sensor	
Communication	<p>Web browser; Web browser (HTML5); Modbus TCP master/slave; Modbus (UDP); Modbus (RTU); ETHERNET; EtherNet/IP™ Adapter (slave); EtherNet/IP™ Scanner; CANopen; EtherCAT® Master; OPC UA Server/Client; OPC UA Pub/Sub (can be installed later); MQTT; RS-232 serial interface; RS-485 interface; BACnet/IP, requires an additional license; Telecontrol protocols, requires an additional license; MicroBrowser (Visualization of CODESYS V2.3), requires an additional license</p> <p>EtherNet/IP™ adapter (slave), library for e!RUNTIME (prerequisite: e!RUNTIME PLC 600 license); Modbus TCP master/slave (prerequisite: e!RUNTIME PLC 600 license); EtherCAT master, requires an additional license (prerequisite: e!RUNTIME PLC 600 license); BACnet/IP, requires an additional license (prerequisite: e!RUNTIME PLC 600 license)</p>	
ETHERNET protocols	DHCP; DNS; FTP; FTPS; HTTP; HTTPS; SSH	
Programming environment	CODESYS V3.5, from firmware release 24; e!COCKPIT (based on CODESYS V3), up to firmware release 22	e!COCKPIT (based on CODESYS V3)
Operating system	Real-time Linux (with RT-Preempt patch)	
Processor	ARM® Cortex® A9 Quadcore 1.0 GHz	
Main memory (RAM)/internal memory (flash)	2 GB / 4 GB	
Program memory/data memory/non-volatile memory (software)	32 MB / 128 MB / 128 KB	32 MB / 128 MB / -
Type of memory card	microSD (max. 2 GB); microSDHC (max. 32 GB)	
Interfaces (USB)	2 x USB host 2.0 (type A)	
Onboard I/Os	Audio; 4 x DIO, configurable	Audio
Dimensions W x H x D	(554 x 358 x 78) mm	(554 x 358 x 58) mm
Panel cutout (W x H)	(540 x 344) mm	
Mounting type	Clamping elements (included)	
Supply voltage	24 VSELV DC (18 ... 31.2 V); with reverse voltage protection	
Input current (typ.)	350 mA; without USB load; 579 mA; with USB load	330 mA; without USB load; 558 mA; with USB load
Operating power	8.4 W, without USB load; 13.9 W, with USB load	7.9 W, without USB load; 13.4 W, with USB load
Ambient temperature (operation)	0 ... +45 °C (when mounted vertically; -0 ... +40 °C, other mounting positions)	
Approvals	CE; OrdLoc	
For data sheet and additional information, see:	wago.com/762-4306/8000-002	wago.com/762-4206/8000-001
Product Expansions	Item no.	Item no.
Runtime; BACnet; 600; Single License; Online activation	2759-286/211-1000	-
Runtime; MicroBrowser; Single License; Online activation	2759-230/211-1000	2759-230/211-1000
Accessories	Item no.	Item no.
Memory Card SD Micro; 2 GB	758-879/000-3102	758-879/000-3102
Memory Card SD Micro; pSLC-NAND; 8 GB	758-879/000-3108	758-879/000-3108

Touch Panels ▶ Advanced Line ▶ 17.8 cm (7 inches)

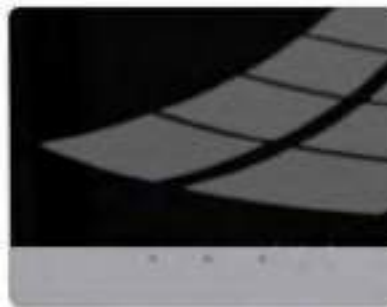

Version	Hardware configuration PIO3; Control Panel	Hardware configuration PIO2; Visu Panel
Item no.	762-5303/8000-002	762-5203/8000-001
Order Text	TP600; 7.0; 800x480; PIO3; CP	TP600; 7.0; 800x480; PIO2; VP
Technical data		
Display	Multitouch glass front; capacitive touchscreen with a glass surface	
Display diagonal	17.8 cm (7 inches)	
Contrast ratio	800:1	
Aspect	16:9	
Display colors	16 million colors	
Graphics resolution	(800 x 480) px	
Viewing angle (horizontal/vertical)	89° / 89°	
Brightness	450 cd/m ²	
Controls	capacitive (glass), 2 capacitive keys, proximity sensor	
Communication	Web browser; Web browser (HTML5); Modbus TCP master/slave; Modbus (UDP); Modbus (RTU); ETHERNET; EtherNet/IP™ Adapter (slave); EtherNet/IP™ Scanner; CANopen; EtherCAT® Master; OPC UA Server/Client; OPC UA Pub/Sub (can be installed later); MQTT; RS-232 serial interface; RS-485 interface; BACnet/IP, requires an additional license ; MicroBrowser (Visualization of CODESYS V2.3), requires an additional license	EtherNet/IP™ adapter (slave), library for e!RUNTIME (prerequisite: e!RUNTIME PLC 600 license); Modbus TCP master/slave (prerequisite: e!RUNTIME PLC 600 license); EtherCAT master, requires an additional license (prerequisite: e!RUNTIME PLC 600 license); BACnet/IP, requires an additional license (prerequisite: e!RUNTIME PLC 600 license)
ETHERNET protocols	DHCP; DNS; FTP; FTPS; HTTP; HTTPS; SSH	
Programming environment	CODESYS V3.5, from firmware release 24; e!COCKPIT (based on CODESYS V3), up to firmware release 22	e!COCKPIT (based on CODESYS V3)
Operating system	Real-time Linux (with RT-Preempt patch)	
Processor	ARM® Cortex® A9 Quadcore 1.0 GHz	
Main memory (RAM)/internal memory (flash)	2 GB / 4 GB	
Program memory/data memory/non-volatile memory (software)	32 MB / 128 MB / 128 KB	32 MB / 128 MB / -
Type of memory card	microSD (max. 2 GB); microSDHC (max. 32 GB)	
Interfaces (USB)	2 x USB host 2.0 (type A)	
Onboard I/Os	Audio; 4 x DIO, configurable	Audio
Dimensions W x H x D	(213 x 167 x 78) mm	(213 x 167 x 58) mm
Panel cutout (W x H)	(198 x 152) mm	
Mounting type	Clamping elements (included) or VESA mount (4 x M4x8)	
Supply voltage	24 VSELV DC (18 ... 31.2 V); with reverse voltage protection	
Input current (typ.)	460 mA, without USB load; 760 mA, with USB load	420 mA, without USB load; 720 mA, with USB load
Operating power	8.8 W, without USB load; 13.9 W, with USB load	8.6 W, without USB load; 13.7 W, with USB load
Ambient temperature (operation)	-20 ... +55 °C (when mounted vertically); -20 ... +50 °C, other mounting positions)	
Approvals	CE; Marine; OrdLoc	
For data sheet and additional information, see:	wago.com/762-5303/8000-002	wago.com/762-5203/8000-001
Product Expansions	Item no.	Item no.
Runtime; BACnet; 600; Single License; Online activation	2759-286/211-1000	-
Runtime; MicroBrowser; Single License; Online activation	2759-230/211-1000	2759-230/211-1000
Runtime; EtherCAT Master; 600; Single License; Online activation	-	2759-266/211-1000
Runtime; IEC 61131 runtime environment; 600; Single License; Online activation	-	2759-216/211-1000
Accessories	Item no.	Item no.
Memory Card SD Micro; 2 GB	758-879/000-3102	758-879/000-3102
Memory Card SD Micro; pSLC-NAND; 8 GB	758-879/000-3108	758-879/000-3108

3

Touch Panels ▶ Advanced Line ▶ 25.7 cm (10.1 inches)

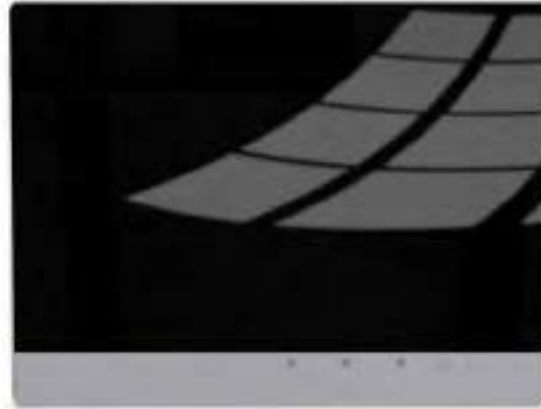

Version	Hardware configuration PIO3; Control Panel	Hardware configuration PIO2; Visu Panel
Item no.	762-5304/8000-002	762-5204/8000-001
Order Text	TP600; 10.1; 1280x800; PIO3; CP	TP600; 10.1; 1280x800; PIO2; VP
Technical data		
Display	Multitouch glass front; capacitive touchscreen with a glass surface	
Display diagonal	25.7 cm (10.1 inches)	
Contrast ratio	800:1	
Aspect	16:9	
Display colors	16 million colors	
Graphics resolution	(1280 x 800) px	
Viewing angle (horizontal/vertical)	85° / 85°	
Brightness	800 cd/m ²	
Controls	capacitive (glass), 2 capacitive keys, proximity sensor	
Communication	Web browser; Web browser (HTML5); Modbus TCP master/slave; Modbus (UDP); Modbus (RTU); ETHERNET; EtherNet/IP™ Adapter (slave); EtherNet/IP™ Scanner; CANopen; EtherCAT® Master; OPC UA Server/Client; OPC UA Pub/Sub (can be installed later); MQTT; RS-232 serial interface; RS-485 interface; BACnet/IP, requires an additional license ; Telecontrol protocols, requires an additional license ; MicroBrowser (Visualization of CODESYS V2.3), requires an additional license	EtherNet/IP™ adapter (slave), library for e!RUNTIME (prerequisite: e!RUNTIME PLC 600 license); Modbus TCP master/slave (prerequisite: e!RUNTIME PLC 600 license); EtherCAT master, requires an additional license (prerequisite: e!RUNTIME PLC 600 license); BACnet/IP, requires an additional license (prerequisite: e!RUNTIME PLC 600 license)
ETHERNET protocols	DHCP; DNS; FTP; FTPS; HTTP; HTTPS; SSH	
Programming environment	CODESYS V3.5, from firmware release 24; e!COCKPIT (based on CODESYS V3), up to firmware release 22	e!COCKPIT (based on CODESYS V3)
Operating system	Real-time Linux (with RT-Preempt patch)	
Processor	ARM® Cortex® A9 Quadcore 1.0 GHz	
Main memory (RAM)/internal memory (flash)	2 GB / 4 GB	
Program memory/data memory/non-volatile memory (software)	32 MB / 128 MB / 128 KB	32 MB / 128 MB / -
Type of memory card	microSD (max. 2 GB); microSDHC (max. 32 GB)	
Interfaces (USB)	2 x USB host 2.0 (type A)	
Onboard I/Os	Audio; 4 x DIO, configurable	Audio
Dimensions W x H x D	(293 x 223 x 78) mm	(293 x 223 x 58) mm
Panel cutout (W x H)	(278 x 208) mm	
Mounting type	Clamping elements (included) or VESA mount (4 x M4x8)	
Supply voltage	24 VSELV DC (18 ... 31.2 V); with reverse voltage protection	
Input current (typ.)	640 mA, without USB load; 940 mA, with USB load	620 mA, without USB load; 920 mA, with USB load
Operating power	11.8 W, without USB load; 17.0 W, with USB load	11.6 W, without USB load; 16.8 W, with USB load
Ambient temperature (operation)	-20 ... +55 °C (when mounted vertically; -20 ... +50 °C, other mounting positions)	
Approvals	CE, Marine, OrdLoc	
For data sheet and additional information, see:	wago.com/762-5304/8000-002	wago.com/762-5204/8000-001
Product Expansions	Item no.	Item no.
Runtime; BACnet; 600; Single License; Online activation	2759-286/211-1000	-
Runtime; MicroBrowser; Single License; Online activation	2759-230/211-1000	2759-230/211-1000
Runtime; EtherCAT Master; 600; Single License; Online activation	-	2759-266/211-1000
Runtime; IEC 61131 runtime environment; 600; Single License; Online activation	-	2759-216/211-1000
Accessories	Item no.	Item no.
Memory Card SD Micro; 2 GB	758-879/000-3102	758-879/000-3102
Memory Card SD Micro; pSLC-NAND; 8 GB	758-879/000-3108	758-879/000-3108

Touch Panels ▶ Advanced Line ▶ 39.6 cm (15.6 inches)



Version	Hardware configuration PIO3; Control Panel	Hardware configuration PIO2; Visu Panel
Item no.	762-5305/8000-002	762-5205/8000-001
Order Text	TP600; 15.6; 1920x1080; PIO3; CP	TP600; 15.6; 1920x1080; PIO2; VP
Technical data		
Display	Multitouch glass front; capacitive touchscreen with a glass surface	
Display diagonal	39.6 cm (15.6 inches)	
Contrast ratio	800:1	
Display colors	16.7 million colors	
Graphics resolution	(1920 x 1080) px	
Viewing angle (horizontal/vertical)	85° / 85°	
Brightness	500 cd/m ²	
Controls	capacitive (glass), 2 capacitive keys, proximity sensor	
Communication	Web browser; Web browser (HTML5); Modbus TCP master/slave; Modbus (UDP); Modbus (RTU); ETHERNET; EtherNet/IP™ Adapter (slave); EtherNet/IP™ Scanner; CANopen; EtherCAT® Master; OPC UA Server/Client; OPC UA Pub/Sub (can be installed later); MQTT; RS-232 serial interface; RS-485 interface; BACnet/IP, requires an additional license ; Telecontrol protocols, requires an additional license ; MicroBrowser (Visualization of CODESYS V2.3), requires an additional license	EtherNet/IP™ adapter (slave), library for e!RUNTIME (prerequisite: e!RUNTIME PLC 600 license); Modbus TCP master/slave (prerequisite: e!RUNTIME PLC 600 license); EtherCAT master, requires an additional license (prerequisite: e!RUNTIME PLC 600 license); BACnet/IP, requires an additional license (prerequisite: e!RUNTIME PLC 600 license)
ETHERNET protocols	DHCP; DNS; FTP; FTPS; HTTP; HTTPS; SSH	
Programming environment	CODESYS V3.5, from firmware release 24; e!COCKPIT (based on CODESYS V3), up to firmware release 22	e!COCKPIT (based on CODESYS V3)
Operating system	Real-time Linux (with RT-Preempt patch)	
Processor	ARM® Cortex® A9 Quadcore 1.0 GHz	
Main memory (RAM)/internal memory (flash)	2 GB / 4 GB	
Program memory/data memory/non-volatile memory (software)	32 MB / 128 MB / 128 KB	32 MB / 128 MB / -
Type of memory card	microSD (max. 2 GB); microSDHC (max. 32 GB)	
Interfaces (USB)	2 x USB host 2.0 (type A)	
Onboard I/Os	Audio; 4 x DIO, configurable	Audio
Dimensions W x H x D	(420 x 283 x 78) mm	(420 x 283 x 58) mm
Panel cutout (W x H)	(406 x 268) mm	
Mounting type	Clamping elements (included)	
Supply voltage	24 VSELV DC (18 ... 31.2 V); with reverse voltage protection	
Input current (typ.)	450 mA; without USB load; 679 mA; with USB load	430 mA; without USB load; 658 mA; with USB load
Operating power	10.8 W, without USB load; 16.3 W, with USB load	10.3 W, without USB load; 15.8 W, with USB load
Ambient temperature (operation)	-20 ... +55 °C (when mounted vertically; -20 ... +50 °C, other mounting positions)	
Approvals	CE; OrdLoc	
For data sheet and additional information, see:	wago.com/762-5305/8000-002	wago.com/762-5205/8000-001
Product Expansions	Item no.	Item no.
Runtime; BACnet; 600; Single License; Online activation	2759-286/211-1000	-
Runtime; MicroBrowser; Single License; Online activation	2759-230/211-1000	2759-230/211-1000
Runtime; EtherCAT Master; 600; Single License; Online activation	-	2759-266/211-1000
Runtime; IEC 61131 runtime environment; 600; Single License; Online activation	-	2759-216/211-1000
Accessories	Item no.	Item no.
Memory Card SD Micro; 2 GB	758-879/000-3102	758-879/000-3102
Memory Card SD Micro; pSLC-NAND; 8 GB	758-879/000-3108	758-879/000-3108

Touch Panels ▶ Advanced Line ▶ 54.7 cm (21.5 inches)



Version	Hardware configuration PIO3; Control Panel	Hardware configuration PIO2; Visu Panel
Item no.	762-5306/8000-002	762-5206/8000-001
Order Text	TP600; 21.5; 1920x1080; PIO3; CP	TP600; 21.5; 1920x1080; PIO2; VP
Technical data		
Display	Multitouch glass front; capacitive touchscreen with a glass surface	
Display diagonal	54.7 cm (21.5 inches)	
Contrast ratio	1000:1	
Display colors	16.7 million colors	
Graphics resolution	(1920 x 1080) px	
Viewing angle (horizontal/vertical)	89° / 89°	
Brightness	350 cd/m ²	
Controls	capacitive (glass), 2 capacitive keys, proximity sensor	
Communication	Web browser; Web browser (HTML5); Modbus TCP master/slave; Modbus (UDP); Modbus (RTU); ETHERNET; EtherNet/IP™ Adapter (slave); EtherNet/IP™ Scanner; CANopen; EtherCAT® Master; OPC UA Server/Client; OPC UA Pub/Sub (can be installed later); MQTT; RS-232 serial interface; RS-485 interface; BACnet/IP, requires an additional license ; Telecontrol protocols, requires an additional license ; MicroBrowser (Visualization of CODESYS V2.3), requires an additional license	EtherNet/IP™ adapter (slave), library for e!RUNTIME (prerequisite: e!RUNTIME PLC 600 license); Modbus TCP master/slave (prerequisite: e!RUNTIME PLC 600 license); EtherCAT master, requires an additional license (prerequisite: e!RUNTIME PLC 600 license); BACnet/IP, requires an additional license (prerequisite: e!RUNTIME PLC 600 license)
ETHERNET protocols	DHCP; DNS; FTP; FTPS; HTTP; HTTPS; SSH	
Programming environment	CODESYS V3.5, from firmware release 24; e!COCKPIT (based on CODESYS V3), up to firmware release 22	e!COCKPIT (based on CODESYS V3)
Operating system	Real-time Linux (with RT-Preempt patch)	
Processor	ARM® Cortex® A9 Quadcore 1.0 GHz	
Main memory (RAM)/internal memory (flash)	2 GB / 4 GB	
Program memory/data memory/non-volatile memory (software)	32 MB / 128 MB / 128 KB	32 MB / 128 MB / -
Type of memory card	microSD (max. 2 GB); microSDHC (max. 32 GB)	
Interfaces (USB)	2 x USB host 2.0 (type A)	
Onboard I/Os	Audio; 4 x DIO, configurable	Audio
Dimensions W x H x D	(554 x 358 x 78) mm	(554 x 358 x 58) mm
Panel cutout (W x H)	(540 x 344) mm	
Mounting type	Clamping elements (included)	
Supply voltage	24 VSELV DC (18 ... 31.2 V); with reverse voltage protection	
Input current (typ.)	350 mA; without USB load; 579 mA; with USB load	330 mA; without USB load; 558 mA; with USB load
Operating power	8.4 W, without USB load; 13.9 W, with USB load	7.9 W, without USB load; 13.4 W, with USB load
Ambient temperature (operation)	0 ... +45 °C (when mounted vertically; -0 ... +40 °C, other mounting positions)	
Approvals	CE; OrdLoc	
For data sheet and additional information, see:	wago.com/762-5306/8000-002	wago.com/762-5206/8000-001
Product Expansions	Item no.	Item no.
Runtime; BACnet; 600; Single License; Online activation	2759-286/211-1000	-
Runtime; MicroBrowser; Single License; Online activation	2759-230/211-1000	2759-230/211-1000
Runtime; EtherCAT Master; 600; Single License; Online activation	-	2759-266/211-1000
Runtime; IEC 61131 runtime environment; 600; Single License; Online activation	-	2759-216/211-1000
Accessories	Item no.	Item no.
Memory Card SD Micro; 2 GB	758-879/000-3102	758-879/000-3102
Memory Card SD Micro; pSLC-NAND; 8 GB	758-879/000-3108	758-879/000-3108

Touch Panels ▶ Marine Line ▶ 10.9 cm (4.3 inches)



Version	Hardware configuration PIO3; Control Panel	Hardware configuration PIO2; Visu Panel
Item no.	762-6301/8000-002	762-6201/8000-001
Order Text	TP600; 4.3; 480x272; PIO3; CP	TP600; 4.3; 480x272; PIO2; VP
Technical data		
Display	Resistive touchscreen (black front)	
Display diagonal	10.9 cm (4.3 inches)	
Contrast ratio	600:1	
Aspect	16:9	
Display colors	16 million colors	
Graphics resolution	(480 x 272) px	
Viewing angle (horizontal/vertical)	80° / 80°	
Brightness	500 cd/m ²	
Controls	Resistive touch panel; 2 capacitive keys; proximity sensor	
Communication	Web browser; Web browser (HTML5); Modbus TCP master/slave; Modbus (UDP); Modbus (RTU); ETHERNET; EtherNet/IP™ Adapter (slave); EtherNet/IP™ Scanner; CANopen; EtherCAT® Master; OPC UA Server/Client; OPC UA Pub/Sub (can be installed later); MQTT; RS-232 serial interface; RS-485 interface; BACnet/IP, requires an additional license ; Telecontrol protocols, requires an additional license ; MicroBrowser (Visualization of CODESYS V2.3), requires an additional license	EtherNet/IP™ adapter (slave), library for e!RUNTIME (prerequisite: e!RUNTIME PLC 600 license); Modbus TCP master/slave (prerequisite: e!RUNTIME PLC 600 license); EtherCAT master, requires an additional license (prerequisite: e!RUNTIME PLC 600 license); BACnet/IP, requires an additional license (prerequisite: e!RUNTIME PLC 600 license)
ETHERNET protocols	DHCP; DNS; FTP; FTPS; HTTP; HTTPS; SSH	
Programming environment	CODESYS V3.5, from firmware release 24; e!COCKPIT (based on CODESYS V3), up to firmware release 22	e!COCKPIT (based on CODESYS V3)
Operating system	Real-time Linux (with RT-Preempt patch)	
Processor	ARM® Cortex® A9 Quadcore 1.0 GHz	
Main memory (RAM)/internal memory (flash)	2 GB / 4 GB	
Program memory/data memory/non-volatile memory (software)	32 MB / 128 MB / 128 KB	32 MB / 128 MB / -
Type of memory card	microSD (max. 2 GB); microSDHC (max. 32 GB)	
Interfaces (USB)	2 x USB host 2.0 (type A)	
Onboard I/Os	Audio; 4 x DIO, configurable	Audio
Dimensions W x H x D	(155 x 135 x 78) mm	(155 x 135 x 58) mm
Panel cutout (W x H)	(140 x 120) mm	
Mounting type	Clamping elements (included) or VESA mount (4 x M4x8)	
Supply voltage	24 VSELV DC (18 ... 31.2 V); with reverse voltage protection	
Input current (typ.)	310 mA; without USB load; 575 mA; with USB load	290 mA, without USB load; 555 mA, with USB load
Operating power	6.0 W, without USB load; 11.5 W, with USB load	5.8 W, without USB load; 11.3 W, with USB load
Ambient temperature (operation)	-20 ... +55 °C (when mounted vertically; -20 ... +50 °C, other mounting positions)	
Approvals	CE; Marine; OrdLoc	
For data sheet and additional information, see:	wago.com/762-6301/8000-002	wago.com/762-6201/8000-001
Product Expansions	Item no.	Item no.
Runtime; BACnet; 600; Single License; Online activation	2759-286/211-1000	-
Runtime; MicroBrowser; Single License; Online activation	2759-230/211-1000	2759-230/211-1000
Runtime; EtherCAT Master; 600; Single License; Online activation	-	2759-266/211-1000
Runtime; IEC 61131 runtime environment; 600; Single License; Online activation	-	2759-216/211-1000
Accessories	Item no.	Item no.
Memory Card SD Micro; 2 GB	758-879/000-3102	758-879/000-3102
Memory Card SD Micro; pSLC-NAND; 8 GB	758-879/000-3108	758-879/000-3108

Touch Panels ► Marine Line ► 14.5 cm (5.7 inches)



Version	Hardware configuration PIO3; Control Panel	Hardware configuration PIO2; Visu Panel
Item no.	762-6302/8000-002	762-6202/8000-001
Order Text	TP600; 5.7; 640x480; PIO3; CP	TP600; 5.7; 640x480; PIO2; VP
Technical data		
Display	Resistive touchscreen (black front)	
Display diagonal	14.5 cm (5.7 inches)	
Contrast ratio	300:1	
Aspect	4:3	
Display colors	262,000 colors	
Graphics resolution	(640 x 480) px	
Viewing angle (horizontal/vertical)	80° / 80°	
Brightness	630 cd/m ²	
Controls	Resistive touch panel; 2 capacitive keys; proximity sensor	
Communication	Web browser; Web browser (HTML5); Modbus TCP master/slave; Modbus (UDP); Modbus (RTU); ETHERNET; EtherNet/IP™ Adapter (slave); EtherNet/IP™ Scanner; CANopen; EtherCAT® Master; OPC UA Server/Client; OPC UA Pub/Sub (can be installed later); MQTT; RS-232 serial interface; RS-485 interface; BACnet/IP, requires an additional license ; Telecontrol protocols, requires an additional license ; MicroBrowser (Visualization of CODESYS V2.3), requires an additional license	EtherNet/IP™ adapter (slave), library for e!RUNTIME (prerequisite: e!RUNTIME PLC 600 license); Modbus TCP master/slave (prerequisite: e!RUNTIME PLC 600 license); EtherCAT master, requires an additional license (prerequisite: e!RUNTIME PLC 600 license); BACnet/IP, requires an additional license (prerequisite: e!RUNTIME PLC 600 license)
ETHERNET protocols	DHCP; DNS; FTP; FTPS; HTTP; HTTPS; SSH	
Programming environment	CODESYS V3.5, from firmware release 24; e!COCKPIT (based on CODESYS V3), up to firmware release 22	e!COCKPIT (based on CODESYS V3)
Operating system	Real-time Linux (with RT-Preempt patch)	
Processor	ARM® Cortex® A9 Quadcore 1.0 GHz	
Main memory (RAM)/internal memory (flash)	2 GB / 4 GB	
Program memory/data memory/non-volatile memory (software)	32 MB / 128 MB / 128 KB	32 MB / 128 MB / -
Type of memory card	microSD (max. 2 GB); microSDHC (max. 32 GB)	
Interfaces (USB)	2 x USB host 2.0 (type A)	
Onboard I/Os	Audio; 4 x DIO, configurable	Audio
Dimensions W x H x D	(172 x 163 x 78) mm	(172 x 163 x 58) mm
Panel cutout (W x H)	(157 x 148) mm	
Mounting type	Clamping elements (included) or VESA mount (4 x M4x8)	
Supply voltage	24 VSELV DC (18 ... 31.2 V); with reverse voltage protection	
Input current (typ.)	360 mA; without USB load; 640 mA; with USB load	340 mA, without USB load; 620 mA, with USB load
Operating power	7.0 W, without USB load; 12.0 W, with USB load	6.8 W, without USB load; 11.8 W, with USB load
Ambient temperature (operation)	-20 ... +55 °C (when mounted vertically; -20 ... +50 °C, other mounting positions)	
Approvals	CE, Marine, OrdLoc	
For data sheet and additional information, see:	wago.com/762-6302/8000-002	wago.com/762-6202/8000-001
Product Expansions	Item no.	Item no.
Runtime; BACnet; 600; Single License; Online activation	2759-286/211-1000	-
Runtime; MicroBrowser; Single License; Online activation	2759-230/211-1000	2759-230/211-1000
Runtime; EtherCAT Master; 600; Single License; Online activation	-	2759-266/211-1000
Runtime; IEC 61131 runtime environment; 600; Single License; Online activation	-	2759-216/211-1000
Accessories	Item no.	Item no.
Memory Card SD Micro; 2 GB	758-879/000-3102	758-879/000-3102
Memory Card SD Micro; pSLC-NAND; 8 GB	758-879/000-3108	758-879/000-3108

Touch Panels ► Marine Line ► 17.8 cm (7 inches)



Version	Hardware configuration PIO3; Control Panel	Hardware configuration PIO2; Visu Panel
Item no.	762-6303/8000-002	762-6203/8000-001
Order Text	TP600; 7.0; 800x480; PIO3; CP	TP600; 7.0; 800x480; PIO2; VP
Technical data		
Display	Resistive touchscreen (black front)	
Display diagonal	17.8 cm (7 inches)	
Contrast ratio	800:1	
Aspect	16:9	
Display colors	16 million colors	
Graphics resolution	(800 x 480) px	
Viewing angle (horizontal/vertical)	89° / 89°	
Brightness	450 cd/m ²	
Controls	Resistive touch panel; 2 capacitive keys; proximity sensor	
Communication	Web browser; Web browser (HTML5); Modbus TCP master/slave; Modbus (UDP); Modbus (RTU); ETHERNET; EtherNet/IP™ Adapter (slave); EtherNet/IP™ Scanner; CANopen; EtherCAT® Master; OPC UA Server/Client; OPC UA Pub/Sub (can be installed later); MQTT; RS-232 serial interface; RS-485 interface; BACnet/IP, requires an additional license ; MicroBrowser (Visualization of CODESYS V2.3), requires an additional license	EtherNet/IP™ adapter (slave), library for e!RUNTIME (prerequisite: e!RUNTIME PLC 600 license); Modbus TCP master/slave (prerequisite: e!RUNTIME PLC 600 license); EtherCAT master, requires an additional license (prerequisite: e!RUNTIME PLC 600 license); BACnet/IP, requires an additional license (prerequisite: e!RUNTIME PLC 600 license)
ETHERNET protocols	DHCP; DNS; FTP; FTPS; HTTP; HTTPS; SSH	
Programming environment	CODESYS V3.5, from firmware release 24; e!COCKPIT (based on CODESYS V3), up to firmware release 22	e!COCKPIT (based on CODESYS V3)
Operating system	Real-time Linux (with RT-Preempt patch)	
Processor	ARM® Cortex® A9 Quadcore 1.0 GHz	
Main memory (RAM)/internal memory (flash)	2 GB / 4 GB	
Program memory/data memory/non-volatile memory (software)	32 MB / 128 MB / -	
Type of memory card	microSD (max. 2 GB); microSDHC (max. 32 GB)	
Interfaces (USB)	2 x USB host 2.0 (type A)	
Onboard I/Os	Audio; 4 x DIO, configurable	Audio
Dimensions W x H x D	(213 x 167 x 78) mm	(213 x 167 x 58) mm
Panel cutout (W x H)	(198 x 152) mm	
Mounting type	Clamping elements (included) or VESA mount (4 x M4x8)	
Supply voltage	24 VSELV DC (18 ... 31.2 V); with reverse voltage protection	
Input current (typ.)	460 mA; without USB load; 760 mA; with USB load	420 mA, without USB load; 720 mA, with USB load
Operating power	8.8 W, without USB load; 13.9 W, with USB load	8.6 W, without USB load; 13.7 W, with USB load
Ambient temperature (operation)	-20 ... +55 °C (when mounted vertically; -20 ... +50 °C, other mounting positions)	
Approvals	CE; Marine; OrdLoc	
For data sheet and additional information, see:	wago.com/762-6303/8000-002	wago.com/762-6203/8000-001
Product Expansions	Item no.	Item no.
Runtime; BACnet; 600; Single License; Online activation	2759-286/211-1000	-
Runtime; MicroBrowser; Single License; Online activation	2759-230/211-1000	2759-230/211-1000
Runtime; EtherCAT Master; 600; Single License; Online activation	-	2759-266/211-1000
Runtime; IEC 61131 runtime environment; 600; Single License; Online activation	-	2759-216/211-1000
Accessories	Item no.	Item no.
Memory Card SD Micro; 2 GB	758-879/000-3102	758-879/000-3102
Memory Card SD Micro; pSLC-NAND; 8 GB	758-879/000-3108	758-879/000-3108

Touch Panels ▶ Marine Line ▶ 25.7 cm (10.1 inches)



Version	Hardware configuration PIO3; Control Panel	Hardware configuration PIO2; Visu Panel
Item no.	762-6304/8000-002	762-6204/8000-001
Order Text	TP600; 10.1; 1280x800; PIO3; CP	TP600; 10.1; 1280x800; PIO2; VP
Technical data		
Display	Resistive touchscreen (black front)	
Display diagonal	25.7 cm (10.1 inches)	
Contrast ratio	800:1	
Aspect	16:9	
Display colors	16 million colors	
Graphics resolution	(1280 x 800) px	
Viewing angle (horizontal/vertical)	85° / 85°	
Brightness	800 cd/m ²	
Controls	Resistive touch panel; 2 capacitive keys; proximity sensor	
Communication	Web browser; Web browser (HTML5); Modbus TCP master/slave; Modbus (UDP); Modbus (RTU); ETHERNET; EtherNet/IP™ Adapter (slave); EtherNet/IP™ Scanner; CANopen; EtherCAT® Master; OPC UA Server/Client; OPC UA Pub/Sub (can be installed later); MQTT; RS-232 serial interface; RS-485 interface; BACnet/IP, requires an additional license ; Telecontrol protocols, requires an additional license ; MicroBrowser (Visualization of CODESYS V2.3), requires an additional license	EtherNet/IP™ adapter (slave), library for e!RUNTIME (prerequisite: e!RUNTIME PLC 600 license); Modbus TCP master/slave (prerequisite: e!RUNTIME PLC 600 license); EtherCAT master, requires an additional license (prerequisite: e!RUNTIME PLC 600 license); BACnet/IP, requires an additional license (prerequisite: e!RUNTIME PLC 600 license)
ETHERNET protocols	DHCP; DNS; FTP; FTPS; HTTP; HTTPS; SSH	
Programming environment	CODESYS V3.5, from firmware release 24; e!COCKPIT (based on CODESYS V3), up to firmware release 22	e!COCKPIT (based on CODESYS V3)
Operating system	Real-time Linux (with RT-Preempt patch)	
Processor	ARM® Cortex® A9 Quadcore 1.0 GHz	
Main memory (RAM)/internal memory (flash)	2 GB / 4 GB	
Program memory/data memory/non-volatile memory (software)	32 MB / 128 MB / -	
Type of memory card	microSD (max. 2 GB); microSDHC (max. 32 GB)	
Interfaces (USB)	2 x USB host 2.0 (type A)	
Onboard I/Os	Audio; 4 x DIO, configurable	Audio
Dimensions W x H x D	(293 x 223 x 78) mm	(293 x 223 x 58) mm
Panel cutout (W x H)	(278 x 208) mm	
Mounting type	Clamping elements (included) or VESA mount (4 x M4x8)	
Supply voltage	24 VSELV DC (18 ... 31.2 V); with reverse voltage protection	
Input current (typ.)	640 mA; without USB load; 940 mA; with USB load	620 mA, without USB load; 920 mA, with USB load
Operating power	11.8 W, without USB load; 17.0 W, with USB load	11.6 W, without USB load; 16.8 W, with USB load
Ambient temperature (operation)	-20 ... +55 °C (when mounted vertically; -20 ... +50 °C, other mounting positions)	
Approvals	CE, Marine, OrdLoc	
For data sheet and additional information, see:	wago.com/762-6304/8000-002	wago.com/762-6204/8000-001
Product Expansions	Item no.	Item no.
Runtime; BACnet; 600; Single License; Online activation	2759-286/211-1000	-
Runtime; MicroBrowser; Single License; Online activation	2759-230/211-1000	2759-230/211-1000
Runtime; EtherCAT Master; 600; Single License; Online activation	-	2759-266/211-1000
Runtime; IEC 61131 runtime environment; 600; Single License; Online activation	-	2759-216/211-1000
Accessories	Item no.	Item no.
Memory Card SD Micro; 2 GB	758-879/000-3102	758-879/000-3102
Memory Card SD Micro; pSLC-NAND; 8 GB	758-879/000-3108	758-879/000-3108

Accessories



Item Description	microSD Memory Card; Temperature range: -40 ... +90 °C	microSD Memory Card; Temperature range: -40 ... +90 °C
Version	SLC-NAND; 2 GB	pSLC-NAND; 8 GB
Item No.	758-879/000-3102	758-879/000-3108
Technical Data		
Memory	2 GB (SLC)	8 GB (pSLC)
Read/write cycles (max.)	20 MB/s / 17 MB/s	48 MB/s / 45 MB/s
MTBF	4,000,000 h	2,000,000 h
Service life	100,000 write cycles (per cell)	20,000 write cycles (per cell)
Data storage	10 years	10 years
Surrounding air temperature (operation)	-40 ... +90 °C	-40 ... +90 °C
Surrounding air temperature (storage)	-40 ... +90 °C	-40 ... +90 °C
Relative humidity	95 %, non-condensing	95 %, non-condensing
Dimensions W x H x D	15 x 11 x 1 mm	15 x 11 x 1 mm
Vibration resistance	15g	15g
Shock resistance	50g	50g



Connection Cable		
USB A-B	Item No.	PU
3 m	758-879/000-101	1

Clamping Element; for Touch Panels		
	Item No.	PU
4 pcs	762-9001	1

3

Flush-Mount Housing for Touch Panels 600



Item Description	WAGO Flush-Mount Housing for Touch Panels 600	
Version	25.7 cm (10.1") 80.0 mm	
Item No.	762-9324	
Technical Data		
Dimensions W x H x D (mm)	293 x 223 x 80	
Panel cutout W x H (mm)	281 x 211	
Weight	1330 g	
Surrounding air temperature (operation)	-20 ... +40 °C	



Item Description	WAGO Flush-Mount Housing for Touch Panels 600	
Version	39.6 cm (15.6") 80.0 mm	
Item No.	762-9325	
Technical Data		
Dimensions W x H x D (mm)	420 x 282 x 80	
Panel cutout W x H (mm)	409 x 271	
Weight	2120 g	
Surrounding air temperature (operation)	-20 ... +40 °C	

Surface-Mounted Housing for Touch Panel 600; Visu Panel

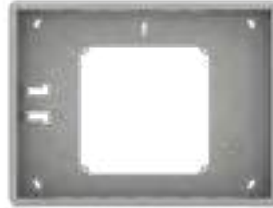

Item Description

Surface-Mounted Housing for Touch Panel 600; 25.7 cm (10.1"); 52.5 mm; Visu Panel

Item No.

762-9214

Technical Data

Dimensions W x H x D (mm)

292.8 x 222.6 x 52.5

Weight

1300 g

3



Item Description

Surface-Mounted Housing for Touch Panel 600; 39.6 cm (15.6"); 52.5 mm; Visu Panel

Item No.

762-9215

Technical Data

Dimensions W x H x D (mm)

420 x 282 x 52.5

Weight

2500 g

Surface-Mounted Housing for Touch Panel 600; Control Panel

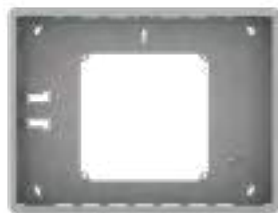

Item Description	Surface-Mounted Housing for Touch Panel 600; 25.7 cm (10.1"); 72.0 mm; Control Panel
Item No.	762-9314
Technical Data	
Dimensions W x H x D (mm)	292.8 x 222.6 x 72
Weight	1600 g

3



Item Description	Surface-Mounted Housing for Touch Panel 600; 39.6 cm (15.6"); 72.0 mm; Control Panel
Item No.	762-9315
Technical Data	
Dimensions W x H x D (mm)	420 x 282 x 72
Weight	3000 g



Edge Computing

Touch Panels 600; Control Panel Hardware Configuration

- Merging of control and visualization
- 10.9 ... 54.7 cm (4.3 ... 21.5")

◀ Section 3

Compact Controller 100

Maximum Performance in Minimum Space:

- Controller with a real-time Linux® operating system
- Compact controller with I/Os in a DIN-rail-mount enclosure
- Manufacturer-independent CODESYS V3 engineering environment

Section 5 ▶

Edge Computing



- Models include Edge Controllers or Edge Computers
- Perfect in-the-field data usage
- Easy cloud connection
- Equipped for high security

Controllers

- Scalable controller family with various interfaces
- Microcontrollers
- Readily combines with the modules of the WAGO I/O System 750

Section 6 ▶▶

Edge Computing Contents

									Page	
General Product Information									94	
Edge Devices, General Product Information									95	
CPU	Modbus (TCP, UDP)	EtherNet/IP	EtherCAT	CANopen	BACnet/IP	Telecontrol Protocols	IoT Protocols	Description	Item No.	
 ARM® Cortex A9; 1 GHz	M/S	M/S	x	x	x*	x*	x	Edge Controller; 2 x ETHERNET, 2 x USB, 1 x USB-C, HDMI, CAN, DI/DO, RS-232/485, Audio; Control	752-8303/8000-002	96
								Edge Computer; 2 x ETHERNET, 4 x USB, HDMI, DP; 4GB RAM; 64GB FLASH	752-9400	98
 Intel® Atom Quad Core E3845 1.91 GHz								Edge Computer; 2 x ETHERNET, 4 x USB, HDMI, DP; 8GB RAM; 64GB FLASH	752-9401	98
								Edge Computer; 4 x ETHERNET, 4 x USB, HDMI, DP; 16 GB RAM, 256 GB Flash	752-9800	99
 Intel® i7-7600U 2.8 GHz										

M: Master, S: Slave; *requires an additional license

Edge Computing

General Product Information

Edge Computing

In many cases, transferring data from machines and systems directly to a cloud solution is resource-intensive and infeasible due to the low latency required in industrial environments. Edge computing has established itself because it combines the advantages of decentralized cloud architectures with those of a local network architecture.

Perfectly Use Data in the Field

Intelligent processes are requiring more and more computing power, and this places corresponding demands on databases directly in the field. WAGO offers the right hardware for any edge application.

Where real-time data is involved, data processing is becoming increasingly important. More and more computing power is needed, and this places corresponding demands on databases, as well as analysis and optimization algorithms, directly in the field. WAGO offers solutions in the form of the Edge Controller and Edge Computer. These devices process applications right on the machine, offloading the controllers so they can focus on their actual control duties with low latency and a high level of determinism.

Easy Cloud Connection

Collected data can be evaluated directly, displayed graphically and made available to WAGO Cloud, for example. Transfer may be appropriate for especially critical data, for instance. Both of the devices have additional advantages when data needs to be buffered temporarily, for instance in mobile applications. They are based on cabinet-compatible hardware and can be powered with 24 V, making them a perfect fit for the automation environment.

Equipped for High Security

With a large share of open source software, the devices are well equipped for cybersecurity because the large open-source community continually reviews the source code and provides bug fixes. Besides the standard VPN applications, the devices are open for special security solutions such as Tosibox and Hooc. Thus, in addition to WAGO's own VPN solution, users can also access other remote maintenance solutions with a high degree of security, in line with the #openandeasy principle. The Edge Computer also offers a TPM 2.0 chip, which provides encryption generators as well as a safe haven for certificates and keys.



WAGO Edge Devices General Product Information



WAGO Edge Controller

The Edge Controller features an ARM Cortex-A9 quad-core processor and offers an extensive selection of interfaces, including two ETHERNET ports, one CANopen port and two USB ports. It also has a serial interface and four digital inputs/outputs for connecting local devices or sensors.

Your Benefits:

- Easy integration into existing systems
- Space-saving installation
- Can be configured in the familiar CODESYS environment

4



WAGO Edge Computer

Where demands on computing power and memory are high, WAGO offers the perfect solution with the Edge Computer. It features a 1.91 GHz quad-core Atom processor or Intel® i7-7600U with 2.8 GHz and is equipped with standard Debian Linux. Users can draw on abundant resources and model entire automation processes on them.

Your Benefits:

- Features high computing power and scalable storage
- Compact and low-maintenance
- Allows use of standard software

Edge Controller; 2 x ETHERNET, 2 x USB, 1 x USB-C, HDMI, CAN, DI/DO, RS-232/485, Audio; Control

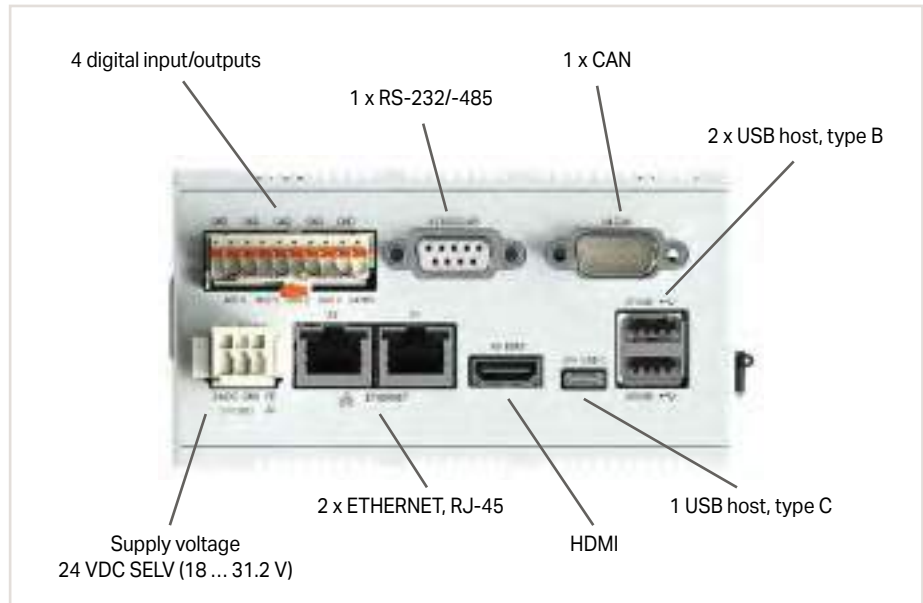

Item Description

Item No.

Order Text

Edge Controller; 2 x ETHERNET, 2 x USB, 1 x USB-C, HDMI, CAN, DI/DO, RS-232/485, Audio; Control

752-8303/8000-002

Edge Controller

Technical Data

Communication

Web browser; Web browser (HTML5); Modbus TCP master/slave; Modbus (UDP); Modbus (RTU); ETHERNET; EtherNet/IP™ Adapter (slave); EtherNet/IP™ Scanner; CANopen; EtherCAT® Master; OPC UA Server/Client; OPC UA Pub/Sub (can be installed later); MQTT; RS-232 serial interface; RS-485 interface; BACnet/IP, requires an additional license; Telecontrol protocols, requires an additional license

Visualization

ETHERNET protocols

Operating system

Processor

Main memory (RAM)

Internal memory (flash)

Non-volatile memory (hardware)

Memory expansion

RTC (Real-Time Clock)

Connection technology: communication/fieldbus

Baud rate

Interfaces

Onboard I/Os

Indicators

Supply voltage

Input current (24 V)

Operating power

Dimensions (W x H x D)

Weight

Housing material

Mounting type

Surrounding air temperature (operation)

Surrounding air temperature (storage)

Protection type

Relative humidity (without condensation)

Approvals

For data sheet and additional information, see:

Web Visu; Target Visu

DHCP, DNS, FTP, FTPS, HTTP, HTTPS, SSH

Real-time Linux (with RT-Preempt patch)

ARM®Cortex® A9

2 GB, DDR3 SDRAM

4 GB, eMMC

128 kB

microSD (max. 2 GB), microSDHC (max. 32 GB)

Maintenance-free, buffering: min. 6 weeks

ETHERNET: 2 x RJ-45 socket;

CAN: D-sub 9 plug;

RS-232/-485: D-sub 9 socket

ETHERNET: 10/100 Mbit/s;

CAN: 1 Mbaud

2 x USB 2.0 socket, type A;

1 x USB OTG socket, type C;

HDMI; Audio

4 x DIO, configurable

3-color LED – red, green, blue; 4 x red/green LED

SELV 24 VDC (–25 ... +30 %), LPS; with reverse voltage protection

120 mA; without USB load;

390 mA; with USB load

2.9 W; without USB load;

9.4 W; with USB load

65 × 123 × 115 mm

815 g

Aluminum, powder-coated

DIN-35-rail mount

–20 ... +60 °C

–20 ... +80 °C

IP20

90 %

CE

wago.com/752-8303/8000-002

Edge Computer; 2 x ETHERNET, 4 x USB, HDMI, DP; 4 or 8 GB RAM, 64 GB Flash

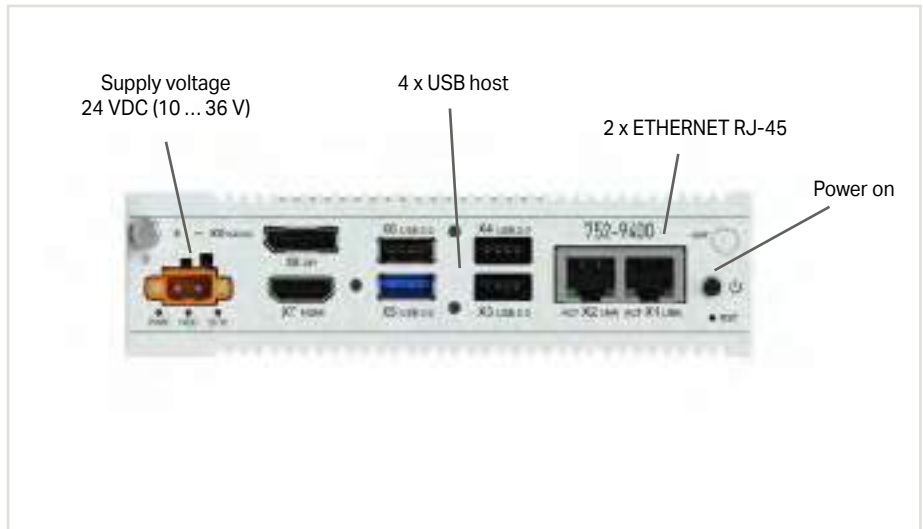

- 2 x ETHERNET interface for connecting to field devices and IT networks
- 4 x USB interface for optional connection of a USB stick, mouse or keyboard
- HDMI and display port interfaces for connecting a display

4

Item Description	Edge Computer; 2 x ETHERNET, 4 x USB, HDMI, DP	
Version	4 GB RAM, 64 GB Flash	8 GB RAM, 64 GB Flash
Item No.	752-9400	752-9401
Order Text	EC; 2ETH, 4USB, HDMI, DP; 4GB RAM, 64GB Flash	EC; 2ETH, 4USB, HDMI, DP; 8GB RAM, 64GB Flash

Technical Data		
Communication	Web browser	
Visualization	Web server	
ETHERNET protocols	DHCP; DNS; HTTP; HTTPS; SSH; SCP; SFTP	
Operating system	Debian Linux 10.9	
Processor	Intel® Atom Quadcore E3845 1.91 GHz	
Main memory (RAM)	4 GB; DDR3L 1333 MHz	8 GB; DDR3L 1333 MHz
Internal memory (flash)	64 GB; mSATA SSD	
Memory expansion	Full-size mPCIe slot; Drive mount for a 2.5" SSD HDD memory card (height: 9.5 mm)	
RTC (Real-Time Clock)	Battery type BR2032; 3 VDC	
Connection technology: communication/fieldbus	ETHERNET: 2 x RJ-45 socket	
Baud rate	ETHERNET: 10/100/1000 Mbit/s	
Interfaces	1 x USB 3.0 socket, Type A; 3 x USB 2.0 socket, Type A; 1 x HDMI v1.4, 1920 x 1080p @60Hz; 1 x DisplayPort 1.2, 2560 x 440p	
Indicators	3 x LED	
Supply voltage	24 VDC (10 ... 36 V)	
Input current (24 V)	1250 mA (typ.); 1750 mA (max.)	
Operating power	30 W (typ.); 42 W (max.)	
Dimensions (W x H x D)	40 x 150 x 105 mm	
Weight	809 g	
Housing material	Aluminum, powder-coated	
Mounting type	DIN-35-rail mount	
Surrounding air temperature (operation)	-20 ... +60 °C	
Surrounding air temperature (storage)	-40 ... +85 °C	
Protection type	IP40	
Relative humidity (without condensation)	95 %	
Approvals	E482462 Ordinary Locations, UL62368	
For data sheet and additional information, see:	wago.com/752-9400	wago.com/752-9401

Edge Computer; 4 x ETHERNET, 4 x USB, HDMI, DP; 16 GB RAM, 256 GB Flash

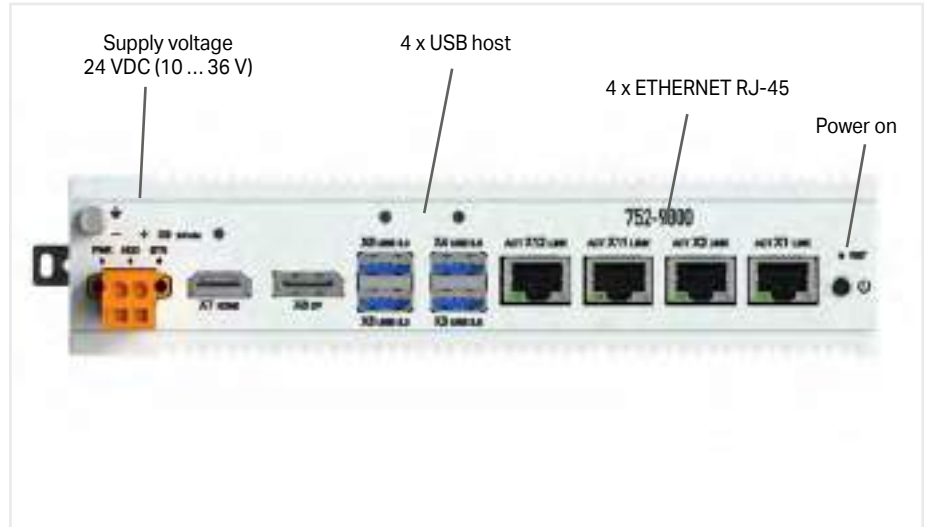

- 4 ETHERNET interfaces for connecting to field devices and IT network
- 4 USB ports for the optional connection of a USB stick, mouse or keyboard
- HDMI and display port interfaces for connecting a display

Item Description	Edge Computer; 4 x ETHERNET, 4 x USB, HDMI, DP; 16 GB RAM, 256 GB Flash
Item No.	752-9800
Order Text	EPC; 4ETH, 4USB, HDMI, DP; 16GB RAM, 256GB Flash
Technical Data	
Communication	Web browser
Visualization	Web server
ETHERNET protocols	DHCP; DNS; HTTP; HTTPS; SSH; SCP; SFTP
Operating system	Debian Linux 10.9
Processor	Intel® i7-7600U 2.8 GHz (max. 3.90 GHz)
Main memory (RAM)	16 GB; DDR4 2133 MHz
Internal memory (flash)	256 GB; SATA 2.5" SSD
Memory expansion	Full-size mPCIe slot; Drive slot for one 2.5" SSD HDD memory card (height 9.5 mm)
RTC (Real-Time Clock)	Battery type BR2032; 3 VDC
Connection technology: communication/fieldbus	ETHERNET: 4 x RJ-45 1000BASE-T
Baud rate	ETHERNET: 10/100/1000 Mbit/s
Interfaces	4 x USB 3.0 (Type A); 1 x HDMI v1.4, 1920 x 1080p @60Hz; 1 x DisplayPort 1.2, 2560 x 440p
Indicators	3 LEDs
Supply voltage	24 VDC (10 ... 36 V)
Input current (24 V)	2292 mA typ.; 3967 mA max.
Operating power	55 W typ.; 95.2 W max.
Dimensions (W x H x D)	45 x 200 x 140 mm
Weight	1810 g
Housing material	Aluminum, powder-coated
Mounting type	DIN-35-rail mount
Surrounding air temperature (operation)	-20 ... +60 °C
Surrounding air temperature (storage)	-40 ... +85 °C
Protection type	IP40
Relative humidity (without condensation)	95 %
Approvals	CE*, FCC*, UL*; *pending
For data sheet and additional information, see:	wago.com/752-9800



Compact Controller 100

Touch Panels 600; Control Panel Hardware Configuration

- Merging of control and visualization
- 10.9 ... 54.7 cm (4.3 ... 21.5")

◀ Section 3

Edge Computing

- Models include Edge Controllers or Edge Computers
- Perfect in-the-field data usage
- Easy cloud connection
- Equipped for high security

◀ Section 4

Compact Controller 100

Maximum Performance in Minimum Space:

- Controller with a real-time Linux® operating system
- Compact controller with I/Os in a DIN-rail-mount enclosure
- Manufacturer-independent CODESYS V3 engineering environment

Controllers

- Scalable controller family with various interfaces
- Microcontrollers
- Readily combines with the modules of the WAGO I/O System 750

Section 6 ▶

Compact Controller 100

Contents

	Page
General Product Information	102
Interfaces and Types	103
Installation Instructions	104
Standards and Rated Conditions	105
Approvals	105



CPU	Modbus (TCP, UDP)	EtherNet/IP™	EtherCAT	Modbus RTU	Telecontrol Protocols	IoT Protocols	Description	Item No.	
Cortex A7; 650 MHz	M/S	M/S	M	x	x*	x	Compact Controller 100; 2 x ETHERNET, RS-485; 8DI, 4DO, 2Ai, 2AO, 2NI1K/PT1K	751-9301	106

M: Master, S: Slave; *requires an additional license

Compact Controller 100

General Product Information

Compact Controller 100: Maximum Performance in Minimum Space

The new WAGO Compact Controller 100 with integrated I/Os offers maximum performance in minimum space.

WAGO's Compact Controller 100 (751-9301) is an attractive solution for various applications that can adapt rapidly to users' needs. The new controller also allows WAGO to solidify its automation portfolio downstream of the proven PFC200. Typical of the WAGO controller family, this Compact Controller runs a real-time Linux operating system and supports standard fieldbus protocols – a clear commitment to openness and interoperability.

Quick and Easy Implementation of IoT Applications

This compact device is freely programmable with CODESYS V3, but can also be used with IEC 61131-independent software, for example, Node-RED, Python or C++. Subsequent installation of Docker® as a virtualization environment is also straightforward. This addition makes the Compact Controller 100 a full-fledged IIoT device with gateway functionality. In this way, WAGO perfectly combines the requirements of two different domains into one device, bringing its expertise to bear where "automation meets IT."

Embedded Linux

Embedded Linux is available for users who prefer to use a lean, secure operating system directly. This real-time Linux® provides a wide range of advantages, including the flexibility of being able to adapt open-source code to your specific needs at any time. Furthermore, this robust operating system ensures a high level of stability and is subject to continuous optimization by the active open-source community. This keeps users both up to date and ready to adapt to what's next – especially when it comes to security.

Engineering with CODESYS V3

The future of automation lies in strong partnerships and co-creation of products and solutions. That's why WAGO offers the Compact Controller 100 with the manufacturer-independent CODESYS V3 automation software. It offers the functions and technologies used in modern automation today, has an active community that keeps it completely up to date and offers users many new options thanks to its manufacturer-independence and interoperability.

Compact Design

Thanks to its design as a DIN-rail built-in installation device (per DIN 43880), the new controller can also be mounted on small distribution boards. The I/O unit is housed in a compact enclosure along with the controller, so no additional space is required for extra control components. The removable wiring interface makes installation and device replacement easier.

Advantages:

- Compact controller with I/Os in a DIN-rail mountable device housing
- Controller with real-time Linux® operating system
- Manufacturer-independent CODESYS V3 engineering environment

Compact Controller 100

Interfaces and Types

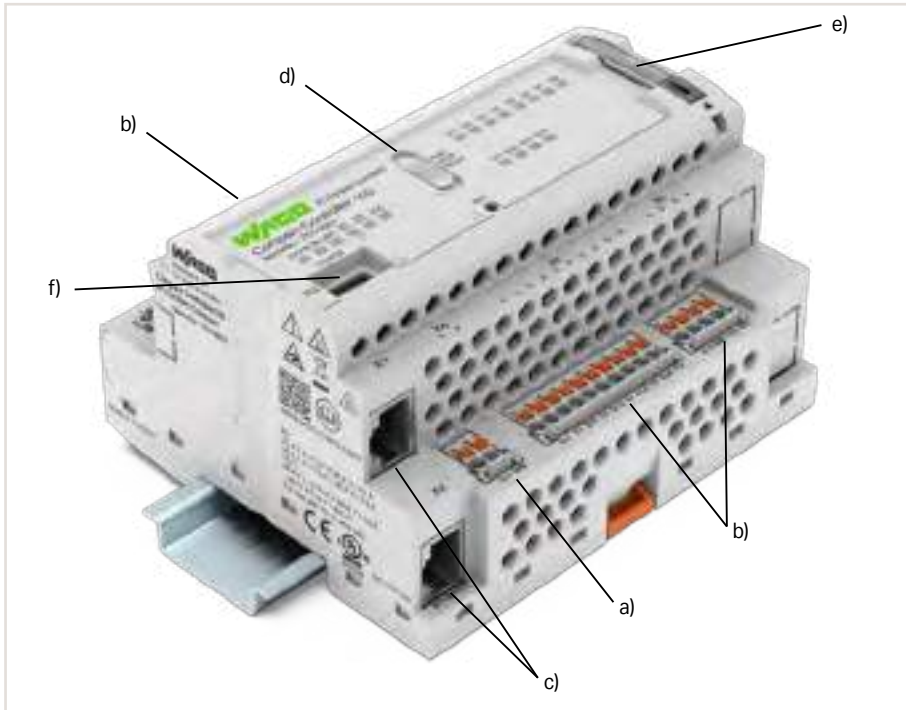

DIN-rail mountable device housing

- Supply voltage (system) (a), Inputs/Outputs and Serial interface (b); Connection technology: picoMAX® 3.5; Push-in CAGE CLAMP®; Conductor range: 0.2 ... 1.5 mm² / 24 ... 14 AWG
- ETHERNET 2 x RJ-45 (c)
- Operating mode switch (d)
- microSD card slot for external storage media (e)
- Service interface USB-C (f)

Compact Controller 100

General Product Information

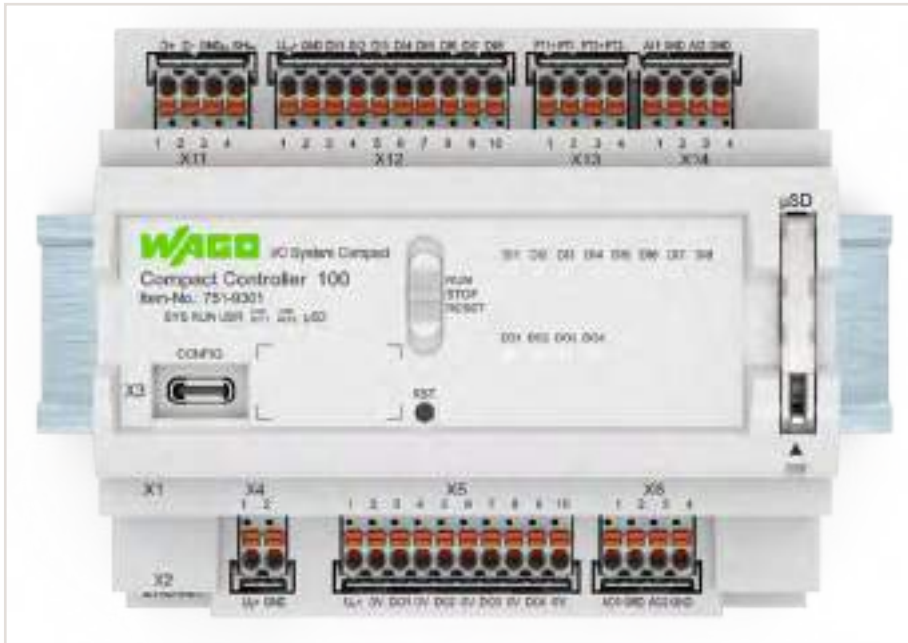

- Communication interface RS-485 – "X11"
- Supply voltage (field) U_{OUT} ; GND; Digital inputs DI1 ... DI8 – "X12"
- Analog temperature sensors PT1 ... PT2 – "X13"
- Analog inputs AI1 ... AI2 – "X14"

- Network connections ETHERNET – "X1", "X2"
- Service interface – "X3"
- Supply voltage system – "X4"
- Supply voltage (field) U_{IN} ; 0 V; Digital outputs DO1 ... DO4 – "X5"
- Analog outputs AO1 ... AO2 – "X6"

5

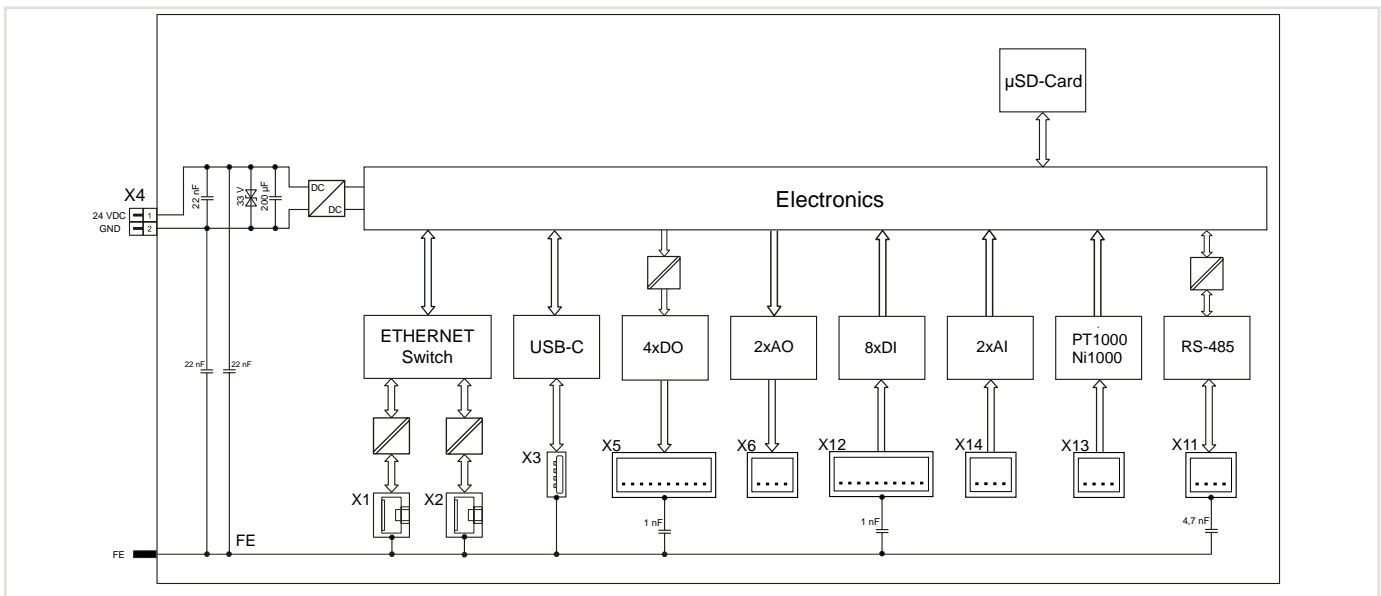

Compact Controller 100

Standards and Rated Conditions

General Specifications	
Programming languages per IEC 61131-3	Instruction List (IL); Ladder Diagram (LD); Function Block Diagram (FBD); Continuous Function Chart (CFC); Structured Text (ST); Sequential Function Chart (SFC)
Programming environment	CODESYS V3.5; Node RED
Configuration options	CODESYS V3.5; ETHERNET Settings; Web-Based Management; WAGO-Upload; WAGO Solution Builder
Baud rate	ETHERNET: 10/100 Mbit/s
Transmission medium (communication/fieldbus)	ETHERNET: Twisted pair S-UTP; 100 Ω; Cat. 5; 100 m maximum cable length
Type of memory card	microSD up to 32 GB (all guaranteed properties only valid with WAGO's memory card)
Memory card slot	Push-push mechanism
Indicators	LED (SYS, RUN), red/green: Status of system; LED (USR) red/green: User programmable status (can be used via CODESYS library); LED (SD) orange: Status of μSD; LED (LNK/ACT) green: Network connection via ports 1 ... 2; LED (DI1 ... 8) green: Status of inputs; LED (DO1 ... 4) green: Status of outputs
Controls	Operating mode switch (RUN, STOP, RESET); reset button
Isolation	1250 V (DC 1 min., between system and field level)
Physical Data	
Width	108 mm / 4.252 inch
Height	90 mm / 3.543 inch
Depth from upper-edge of DIN-rail	55 mm / 2.165 inch
Mechanical Data	
Weight	348 g
Housing material	Polycarbonate, polyamid
Environmental Requirements	
Ambient temperature (operation)	-25 ... +60 °C
Ambient temperature (storage)	-40 ... +85 °C
Protection type	IP20
Pollution degree	2 per IEC 61131-2
Operating altitude	0 ... 2000 m / 0 ... 6562 ft
Relative humidity (without condensation)	95 %
Mounting position	any
Mounting type	DIN-35 rail
Vibration resistance	1g per IEC 60068-2-6
Shock resistance	15g per IEC 60068-2-27
EMC immunity to interference	per EN 61000-6-2
EMC emission of interference	per EN 61000-6-3

Compact controller ▶ 2 x ETHERNET, RS-485; 8DI, 4DO, 2Ai, 2AO, 2NI1K/PT1K



751-9301

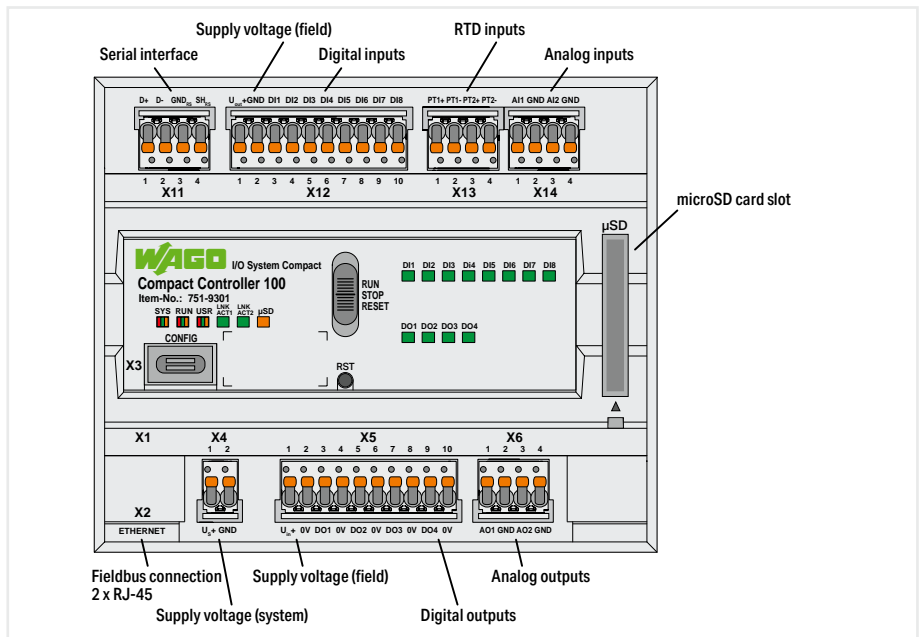

Version
Item no.
Order Text

Standard
751-9301
Compact Controller 100

Technical data
Communication

Modbus (TCP, UDP); EtherCAT® Master; EtherNet/IP™ Adapter (slave); EtherNet/IP™ Scanner; Modbus® RTU; RS-485 interface; MQTT; Telecontrol protocols, **requires an additional license**
 DHCP; DNS; NTP; FTP; FTPS; SNMP; HTTP; HTTPS; SSH

ETHERNET protocols
Visualization
Programming environment

Web-Visu
 CODESYS V3.5; Node RED

CPU
Operating system

Cortex A7; 650 MHz
 Real-time Linux (with RT-Preempt patch)

Main memory (RAM)
Internal memory (flash)
Non-volatile hardware memory
Data memory
Program memory
Non-volatile software memory

512 MB
 4096 MB
 128 KB
 128 MB
 32 MB
 128 KB

Supply voltage (system)
Supply voltage (field)
Current consumption (system) max.
Current consumption (field) max.

24 VDC (-15 ... +20 %); via pluggable connector (*picoMAX*® 3.5; Push-in CAGE CLAMP® connection)
 24 VDC (-15 ... +20 %); via pluggable connector (*picoMAX*® 3.5; Push-in CAGE CLAMP® connection)
 500 mA
 2000 mA

Signal type

Voltage; Resistance measurement

Number of digital inputs

8

Input characteristic

Type 3 (per EN 61131-2)

Number of digital outputs

4

Output current (per channel)

500 mA (DC)

Output current

short-circuit-protected

Signal type (voltage)

0 ... 10 VDC

Number of analog inputs

2

Resolution of analog inputs

16 bits

Number of analog outputs

2

Resolution of analog outputs

12 bits

Load impedance (voltage output)

≥ 5 kΩ

Number of measurement inputs

2

Temperature range

-60 °C ... 350 °C, PT1000, Ni1000

Ambient temperature (operation)

-25 ... +60 °C

Approvals

C E; UKCA; OrdLoc

For data sheet and additional information, see:

wago.com/751-9301

Accessories
Memory Card SD Micro; 2 GB
Memory Card SD Micro; pSLC-NAND; 8 GB

Item no.
758-879/000-3102
758-879/000-3108

5



Controllers

Touch Panels 600; Control Panel Hardware Configuration

- Merging of control and visualization
- 10.9 ... 54.7 cm (4.3 ... 21.5")

◀◀◀ Section 3

Edge Computing

- Models include Edge Controllers or Edge Computers
- Perfect in-the-field data usage
- Easy cloud connection
- Equipped for high security

◀◀ Section 4

Compact Controller 100

Maximum Performance in Minimum Space:

- Controller with a real-time Linux® operating system
- Compact controller with I/Os in a DIN-rail-mount enclosure
- Manufacturer-independent CODESYS V3 engineering environment

◀ Section 5

Controllers PFC100/PFC200

- Maximum performance in a minimum space
- Also programmable in high-level languages based on Linux®
- Security packages with SSH and SSL/TLS
- Runtime system for CODESYS V3

Section 6.1 ▶

Controllers PFC200 XTR

- The advantages of WAGO's PFC Controllers combined with the capabilities for extreme environments:
- High processing speed
- Multiple interfaces
- eXTRemely robust and maintenance-free

Section 6.2 ▶▶

Basic Controllers 100

- Freely programmable per IEC 61131-3 with CODESYS V3
- HTML-5-based Web visualization
- Syslog in compliance with RFC 5424 and role-based user management (RBAC)
- Large amount of memory for projects and data

Section 6.3 ▶▶▶

Controllers 750

- Controllers for all common fieldbus systems
- Programmable per IEC 61131-3
- Readily combines with the modules of the WAGO I/O System 750

Section 6.4 ▶▶▶▶

Controllers 750 XTR

- For demanding applications in which the following are critical:
- Extreme temperature resistance
- Immunity to electromagnetic interference and impulse voltages
- Vibration and shock resistance

Section 6.5 ▶▶▶▶▶

Starter Kits

For the entry into the most diverse application possibilities

IoT Boxes

Integrating machines and plants into the Internet of Things

Section 6.6 ▶▶▶▶▶▶

Controllers Overview

	Section	Page
	Touch Panels 600; Control Panel Hardware Configuration Combining controller and visualization into one device	3 67
	Edge Computing Edge Controller	4 93
	Compact Controller 100 Compact controller with I/Os in a DIN-rail-mount enclosure	5 101
	Controllers PFC100 and PFC200 Scalable IP20 controller family with various interfaces	6.1 111
	Controllers PFC200 XTR Scalable IP20 controllers with various interfaces for eXTReme environmental conditions	6.2 131
	Basic Controllers 100 IP20 microcontrollers; programmable with CODESYS V3	6.3 143
	Controllers 750 IP20 microcontrollers	6.4 151
	Controllers 750 XTR IP20 microcontrollers for eXTReme environments	6.5 173
	Starter Kits For the entry into the most diverse application possibilities	6.6 181
	IoT Boxes Integrating machines and plants into the Internet of Things	

Benefits:

- Fieldbus-independent – compatible with all prominent fieldbus protocols and ETH-ERNET standards
- Scalable performance – Controllers, Control Panels, PFC100 and PFC200
- Programming per IEC 61131-3
- Flexible platform adapts to diverse applications and environments
- Combinable with the WAGO I/O System 750 – modular, compact, versatile



Controllers PFC100/PFC200

Controllers PFC100/PFC200

- Maximum performance in a minimum space
- Also programmable in high-level languages based on Linux®
- Security packages with SSH and SSL/TLS
- Runtime system for CODESYS V3

Controllers PFC200 XTR

- The advantages of WAGO's PFC Controllers combined with the capabilities for extreme environments:
- High processing speed
- Multiple interfaces
- eXTRemely robust and maintenance-free

Basic Controllers 100

- Freely programmable per IEC 61131-3 with CODESYS V3
- HTML-5-based Web visualization
- Syslog in compliance with RFC 5424 and role-based user management (RBAC)
- Large amount of memory for projects and data

Section 6.2 ►

Section 6.3 ►►

Controllers 750

- Controllers for all common fieldbus systems
- Programmable per IEC 61131-3
- Readily combines with the modules of the WAGO I/O System 750

Controllers 750 XTR

- For demanding applications in which the following are critical:
- Extreme temperature resistance
- Immunity to electromagnetic interference and impulse voltages
- Vibration and shock resistance

Starter Kits

For the entry into the most diverse application possibilities

IoT Boxes

Integrating machines and plants into the Internet of Things

Section 6.4 ►►►











Section 6.5 ►►►►

Section 6.6 ►►►►►

Controllers PFC100/PFC200

Contents

General Product Information	Page	112
Variants		113
Interfaces and Types		113
Installation Instructions		114
Item Number Key		114
Standards and Rated Conditions		115
Approvals		115

CPU	Modbus (TCP, UDP)	EtherNet/IP™	EtherCAT	PROFINET	PROFIBUS	CANopen	BACnet/IP	OPC UA	Modbus RTU	Telecontrol Protocols	IoT Protocols	Description	Item No.		
													Standard	Extended Temperature	
 Cortex A8; 600 MHz	M/S	S									x	Controller PFC100; 2 x ETHERNET; Eco	750-8100		116
 Cortex A8; 600 MHz	M/S	S									x	Controller PFC100; 2 x ETHERNET	750-8101	750-8101/025-000	117
	M/S	S							x		x	Controller PFC100; 2 x ETHERNET, RS-232/-485	750-8102	750-8102/025-000	118
 Cortex A8; 1 GHz	M/S	M/S	M				x*	x	x	x*	x	Controller PFC200; 2nd Generation; 4 x ETHERNET	750-8210	750-8210/025-000	119
 Cortex A8; 1 GHz	M/S	M/S	M				x*	x	x	x*	x	Controller PFC200; 2nd Generation; 2 x ETHERNET, 2 x SFP-Ports	750-8211		120
 Cortex A8; 1 GHz	M/S	M/S	M				x*	x	x	x*	x	Controller PFC200; 2nd Generation; 2 x ETHERNET, RS-232/-485	750-8212	750-8212/025-000	121
	M/S	M/S	M				x*	x	x	x	x	Telecontrol Technology		750-8212/025-001 750-8212/025-002	121
	M/S	M/S	M				x	x	x	x*	x	BACnet/IP	750-8212/000-100		122
 Cortex A8; 1 GHz	M/S	M/S	M		M/S		x*	x		x*	x	Controller PFC200; 2nd Generation; 2 x ETHERNET, CAN, CANopen	750-8213		123
 Cortex A8; 1 GHz	M/S	M/S	M		M/S			x	x	x*	x	Controller PFC200; 2nd Generation; 2 x ETHERNET, RS-232/-485, CAN, CANopen	750-8214		124
 Cortex A8; 1 GHz	M/S	M/S	M	S	M/S			x		x*	x	Controller PFC200; 2nd Generation; 4 x ETHERNET, CAN, CANopen, USB	750-8215		125
 Cortex A8; 1 GHz	M/S	M/S	M	S	M/S		x*	x	x	x*	x	Controller PFC200; 2nd Generation; 2 x ETHERNET, RS-232/-485, CAN, CANopen, PROFIBUS Slave	750-8216	750-8216/025-000	126
	M/S	M/S	M	S	M/S		x*	x	x	x	x	Telecontrol Technology		750-8216/025-001	126
 Cortex A8; 1 GHz	M/S	S	M*				x*		x	x*	x	Controller PFC200; 2nd Generation; 2 x ETHERNET, RS-232/-485, Mobile Radio Module 4G	750-8217	750-8217/025-000	127
												Global Variant	750-8217/600-000	750-8217/625-000	128
 Cortex A8; 600 MHz	M/S	S		M					x		x	Controller PFC200; 2 x ETHERNET, RS-232/-485, CAN, CANopen, PROFIBUS Master	750-8208	750-8208/025-000	129
	M/S	S		M					x	x	x	Telecontrol Technology		750-8208/025-001	129

M: Master, S: Slave; *requires an additional license

Controllers PFC100/PFC200

General Product Information

PFC100/PFC200:

Maximum Performance in a Minimum Space

As a member of the WAGO control family, the PFC100/PFC200 Controllers with CODESYS V3 excel with high processing speed and multiple interfaces for parallel communication. All variants feature at least two ETHERNET ports and – depending on the model – additional interfaces. The CANopen, PROFIBUS DP, Modbus TCP/UPD/RTU, PROFINET, EtherNet/IP and EtherCAT protocols provide a flexible connection to fieldbus systems and external input/output devices. These fieldbus systems can be easily configured directly in the development environment.

The ETHERNET interfaces with an integrated switch also support all major IT protocols. In addition to multiple interfaces, the PFC100/PFC200 Controllers offer ample memory for your applications provided by the internal flash memory and an integrated interface for memory cards.

Industry 4.0 / IoT

Recording, digitizing and linking data profitably – these are the core ideas of Industry 4.0. Using a dedicated library, WAGO's PFC100/PFC200 Controllers become IoT controllers that send data from the field level to the cloud. Once in the cloud, data can be aggregated and used for analysis. This capability creates tremendous added value for your company – whether it's increasing the efficiency of in-house production, implementing energy management in buildings or developing additional end-customer services. Existing systems also become IoT-ready, making them future-proof. The WAGO PFC family of controllers thus forms the basis for a sustainable corporate world.

Telecontrol Technology

Standardized telecontrol protocols according to IEC 60870-5, IEC 61850, IEC 61400-25 or DNP3 ensure use of the PFC Controllers in telecontrol technology.

Starter Kits

For a quick start, WAGO offers every customer the unique opportunity to purchase a starter kit that already contains all the components needed to begin programming and getting to know the controllers. For starter kits, see Section 6.6.

Link between Process Data and IT Application

The PFC100/PFC200 Controllers ideally combine real-time requirements with IT functionality. They support both Modbus/TCP and EtherNet/IP for use in industrial environments. HTTP, SNMP, FTP, BootP, DHCP, DNS, Telnet, SSH and other protocols simplify integration into IT environments. Integrated Web pages and Web-based visualization provide IT applications with real-time process data. Furthermore, the controllers incorporate library functions for email, SOAP, ASP, IP configuration, ETHERNET sockets and file system.

Security on Board

The topics of ETHERNET communication and security are closely linked. To provide PFC Controller users with a high level of security, mechanisms for secure connections such as VPN, integrated firewall, HTTPS, FTPS, SSH and SSL/TLS are standard.

Demand-Oriented Extensibility

Some controllers offer the option of activating functions that go beyond the standard via runtime licenses, making it possible to price as needed. This also offers the advantage that with the same exact controller, different functions can be realized and also combined, which otherwise would only be replicated via additional variants. The licenses are simply loaded into the controller together with the project. The additional licenses available for each controller are specified by the controller and described in detail in the "Software" section.

Worldwide Approvals

International approvals for building and industrial automation, as well as the process and marine industries, guarantee worldwide use – even under harsh operating conditions. These recognitions include: ATEX, BR-Ex, IECEx, UL508, UL ANSI/ISA, AEx and numerous marine certifications.

Modular and Expandable

With the WAGO I/O System 750, the PFC100/PFC200 Controllers can be expanded to almost any input/output interface. A modular, DIN-rail-mount design permits easy installation, expansion and modification of the I/O node without tools. The straightforward design prevents installation errors. Additionally, proven CAGE CLAMP® technology ensures that all connections made in the field are quick, vibration-proof and maintenance-free. Depending on the I/O modules' granularity, the field level can be directly wired using 1-, 2-, 3- or 4-conductor technology.

Maximum Reliability and Ruggedness

The PFC100/PFC200 Controllers are engineered and tested for use in the most demanding environments (e.g., temperature cycling, shock/vibration loading and ESD) according to the highest standards. Spring pressure connection technology guarantees continuous operation. Integrated QA measures in the production process and 100% function testing ensure consistent quality.

Open-Source Software and Linux®

We unite what belongs together: High-performance WAGO Hardware and future-ready Linux® Operating System. For complex tasks, you can choose between programming in IEC 61131 or directly under Linux®. WAGO's "Embedded Linux" Controllers impress with base images that are expandable via open-source packages. As a "Gold Member" of the Open Source Automation Development Lab (OSADL), WAGO supports both financing and further development of Linux® in the industrial sector. The controller firmware itself is available as a "Board Support Package" (BSP). If you are interested, simply contact our AUTOMATION technical support.



Benefits:

- Programming per IEC 61131-3
- Applications with higher-level languages
- Linux® real-time operating system
- Rugged and maintenance-free
- Integrated cybersecurity packages
- IoT ready

Controllers PFC100/PFC200 Variants

Extended Temperature Range

Industrial automation technology is typically operated in temperatures ranging from 0°C to 55°C. However, there are applications like telecontrol technology that require an extended temperature range. Select controllers are available in an extended temperature range of -20°C to +60°C.



Eco

The Eco version of the PFC200 limits the number of I/O modules to four.

Telecontrol Technology

The PFC200 models for telecontrol technology integrate the following standardized telecontrol protocols:

- IEC 60870-5
- IEC 61850
- IEC 61400-25
- DNP3

Interfaces and Types

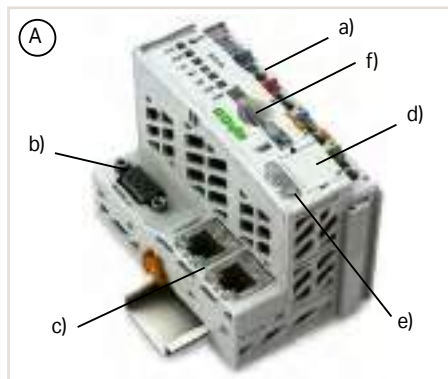

- Includes a supply module (a) to power downstream I/O modules; Connection technology (system/field supply): CAGE CLAMP®; Conductor range: 0.08 ... 2.5 mm²/28 ... 14 AWG
- Technical differences on the connection level (b)
- ETHERNET 2 x RJ-45 (c)
- Service interface (d)
- Start/stop switch (e)

Housing Design PFC100 (A, B)

- microSD card slot for external storage media (f)

Housing Design PFC200 (C, D, E, F, G, H)

- SD card slot for external storage media (g)

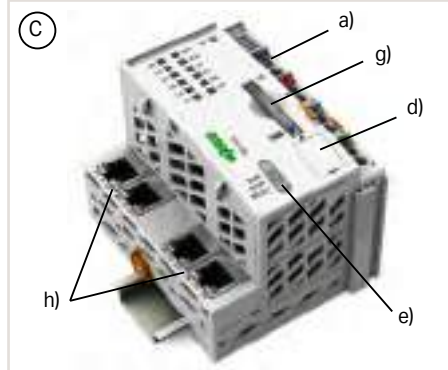
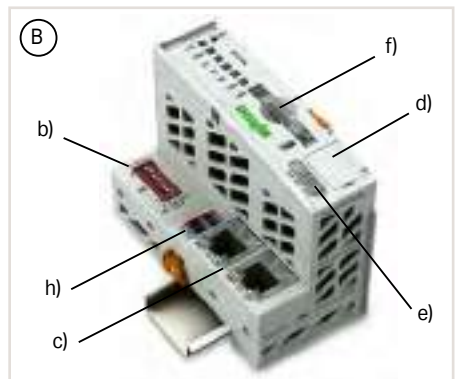

Housing Design (A)

- W x H x D (mm): 61.5 x 100 x 71.9

Housing Design (B)

- W x H x D (mm): 49.5 x 96.8 x 71.9
- Supply system connection technology (h): CAGE CLAMP®; Conductor range: 0.08 ... 1.5 mm²/28 ... 16 AWG

Housing Design (C)

- ETHERNET 4 x RJ-45 (h)
- W x H x D (mm): 78.6 x 100 x 71.9

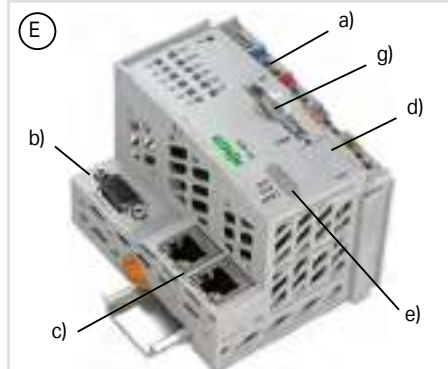
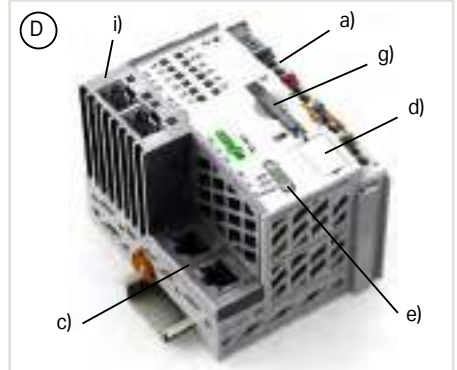

Housing Design (D)

- 2 x SFP port; 100BASE-FX, LC, fiber optic (SFP type) (i)
- W x H x D (mm): 78.6 x 100 x 71.9

Housing Design (E)

- W x H x D (mm): 78.6 x 100 x 71.9

Housing Design (F)

- ETHERNET 4 x RJ-45 (j)
- USB interface (k)
- W x H x D (mm): 112 x 100 x 71.9

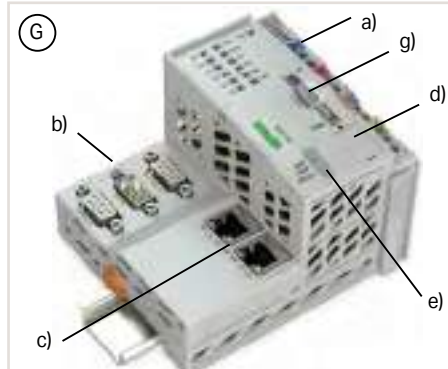
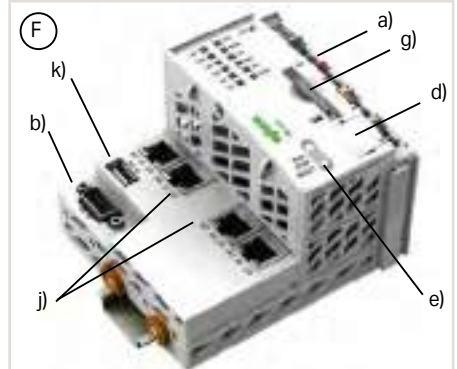

Housing Design (G)

- W x H x D (mm): 112 x 100 x 71.9

Housing Design (H)

- GSM antenna connection (m)
- SIM card slot (n)
- W x H x D (mm): 102.5 x 100 x 71.9

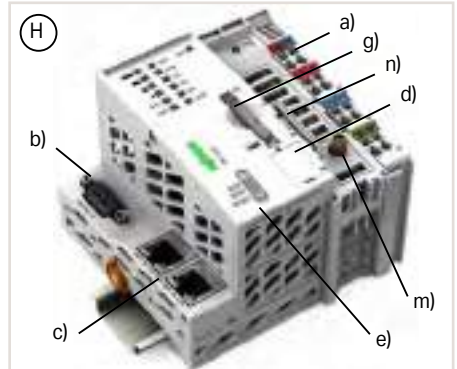

Controllers PFC100/PFC200 Installation Instructions

Power Supply

The internal electronics are powered by the controller. The power supply to the field-side supply is electrically isolated. This division enables a separate supply for sensors and actuators. Snapping the I/O modules together automatically routes the supply voltages. Supply modules with diagnostics also enable power supply monitoring. This ensures a flexible and customized supply configuration for a fieldbus node. Power supply to the electronics is limited by a maximum value. If the sum of the internal current demand of all the I/O modules should exceed this value, an additional system supply module is necessary. Furthermore, the current consumed for field-side supply must not exceed 10 A. A variety of power supply modules allows re-feeding, creating potential groups and implementing emergency stops.

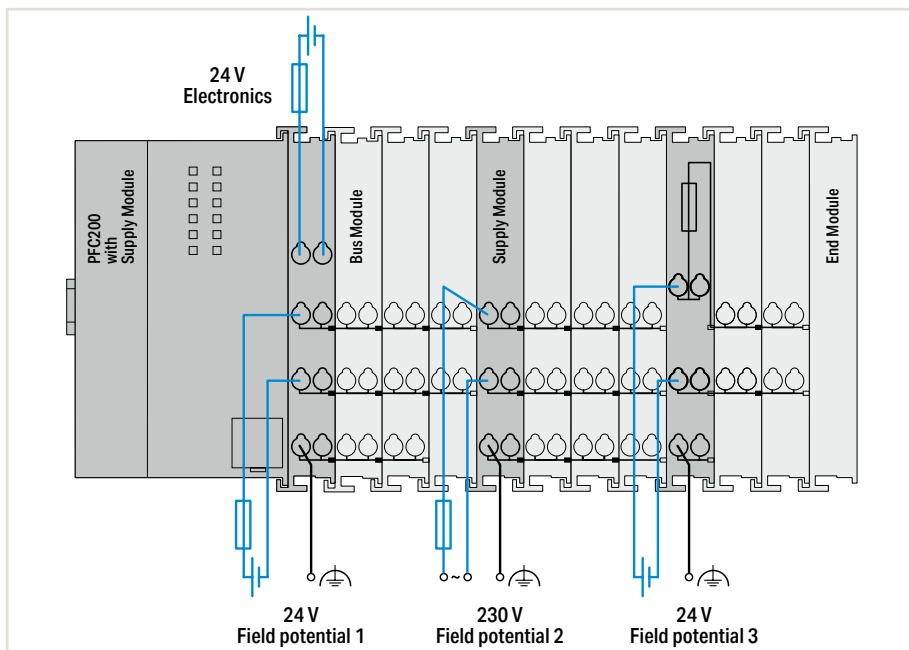

Notes

Additional steps must be implemented based on where the I/O system is installed:

Specific power and field-side power supply filters (750-624 or 750-626) are required for marine and onshore/offshore applications.

A specific supply module (750-606) is required to operate intrinsically safe Ex i modules.

Additionally, both a supply module and a field-side power supply filter are recommended when operating intrinsically safe Ex i modules for marine and onshore/offshore applications.

When operating safety-related I/O modules, PELV/SELV power supply units must be used for 24 VDC supply of electronics and field. Furthermore, specific power and field-side power supply filters (750-626) must be provided.

Please refer to the manual for details about the power supply's design.

Item Number Key

Explanation of an item number key's components

6.1

Item No. : 750-81xx = PFC100

- 00: 2 x ETHERNET, Eco
- 01: 2 x ETHERNET
- 02: 2 x ETHERNET, RS-232/-485

Item No. : 750-82xy = PFC200

- 0y: Generation 1
- 1y: Generation 2
- x0: 4 x ETHERNET
- x1: 2 x ETHERNET, 2 x SFP Port
- x2: 2 x ETHERNET, RS-232/-485
- x3: 2 x ETHERNET, CAN
- x4: 2 x ETHERNET, RS-232/-485, CAN
- x5: 4 x ETHERNET, CAN, CANopen, USB
- x6: 2 x ETHERNET, RS-232/-485, CAN, PROFIBUS DP Slave
- x7: 2 x ETHERNET, RS-232/-485, Mobile Radio Module
- x8: 2 x ETHERNET, RS-232/-485, CAN, CANopen, PROFIBUS Master

.../025-yyy: Extended Temperature Range (-20 ... +60 °C)

- 000: Standard
- 001: Telecontrol Technology
- 002: Telecontrol Eco

Standards and Rated Conditions

General technical data	
Isolation	500 V system/field
Relative humidity (without condensation)	95 %
Operating altitude	without temperature derating: 0 ... 2000 m; with temperature derating: 2000 ... 5000 m (0.5 K/100 m); 5000 m (max.)
Pollution degree	2 per IEC 61131-2
Shock resistance	15g per IEC 60068-2-27
EMC immunity to interference	per EN 61000-6-2, marine applications
Protection type	IP20
Mounting position	any
Mounting type	DIN-35 rail
Housing material	Polycarbonate; polyamide 6.6
Exposure to pollutants	per IEC 60068-2-42 and IEC 60068-2-43
Permissible SO ₂ contaminant concentration at a relative humidity 75 %	25 ppm
Permissible H ₂ S contaminant concentration at a relative humidity 75 %	10 ppm
Connection technology: system supply	2 x CAGE CLAMP®

Approvals

For approvals overview (item comparison), see Section 14 (Technical Section) or visit www.wago.com.



Antenna	Page 630
Cables and connectors	Page 680
Communication	Page 678
DIN-rail	Page 716
Marking	Page 714
Shield termination	Page 708
Software	Page 51
System enclosure	Page 693

Controller PFC100 ▶ 2 x ETHERNET; ECO



750-8100

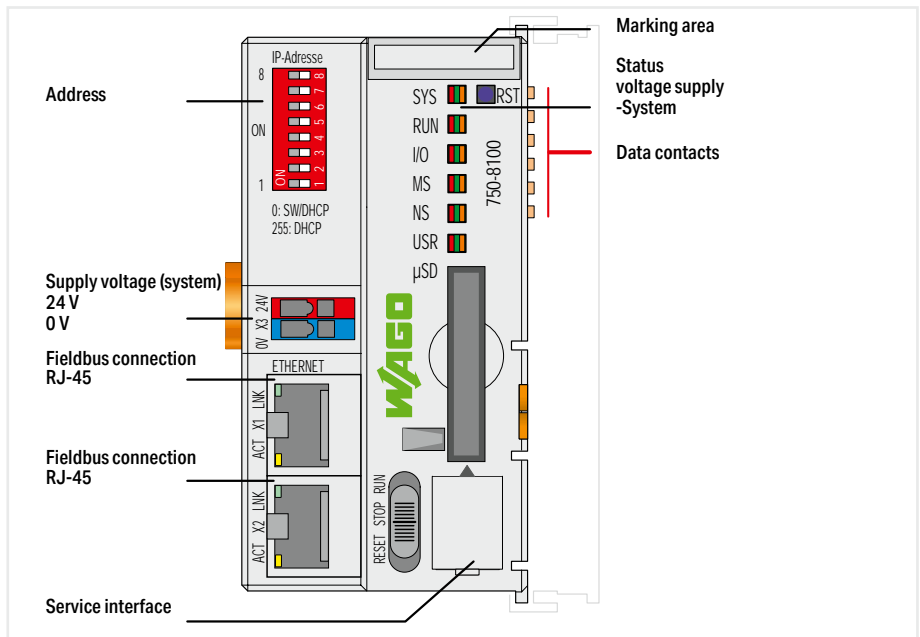

Version	Standard
Item no.	750-8100
Order Text	PFC100; 2ETH; ECO

Technical data	
Communication	Modbus (TCP, UDP); ETHERNET; EtherNet/IP™ Adapter (slave), library for <i>e!RUNTIME</i> ; MQTT
ETHERNET protocols	DHCP; DNS; NTP; FTP; FTPS; SNMP; HTTP; HTTPS; SSH
Visualization	Web-Visu
Programming environment	<i>e!COCKPIT</i> (based on CODESYS V3)
CPU	Cortex A8; 600 MHz
Operating system	Real-time Linux 3.18 (with RT-Preempt patch)
Main memory (RAM)/internal memory (flash)/non-volatile memory (hardware)	256 MB / 256 MB / 64 KB
Program memory/data memory/non-volatile memory (software)	10 MB / 10 MB / 64 KB (Program and data memory (dynamically distributed))
Number of modules per node (max.)	250
Input and output process image (internal) max.	1000 words/1000 words
Input and output process image (Modbus®) max.	CODESYS V3: 32000 words/32000 words
Supply voltage (system)	24 VDC (-25 ... +30 %); via pluggable connector
Input current (typ.) at nominal load (24 V)	300 mA
Total current (system supply)	700 mA
Ambient temperature (operation)	0 ... +55 °C
Dimensions W x H x D	(49.5 x 96.8 x 71.9) mm
Approvals	CE; Marine; OrdLoc/HazLoc; ATEX/IECEX
For data sheet and additional information, see:	wago.com/750-8100

Accessories	Item no.
Memory Card SD Micro; 2 GByte	758-879/000-3102
Memory Card SD Micro; pSLC-NAND; 8 GB; Temperature range: -40 to 90°C	758-879/000-3108

6.1

Controller PFC100 ▶ 2 x ETHERNET



750-8101

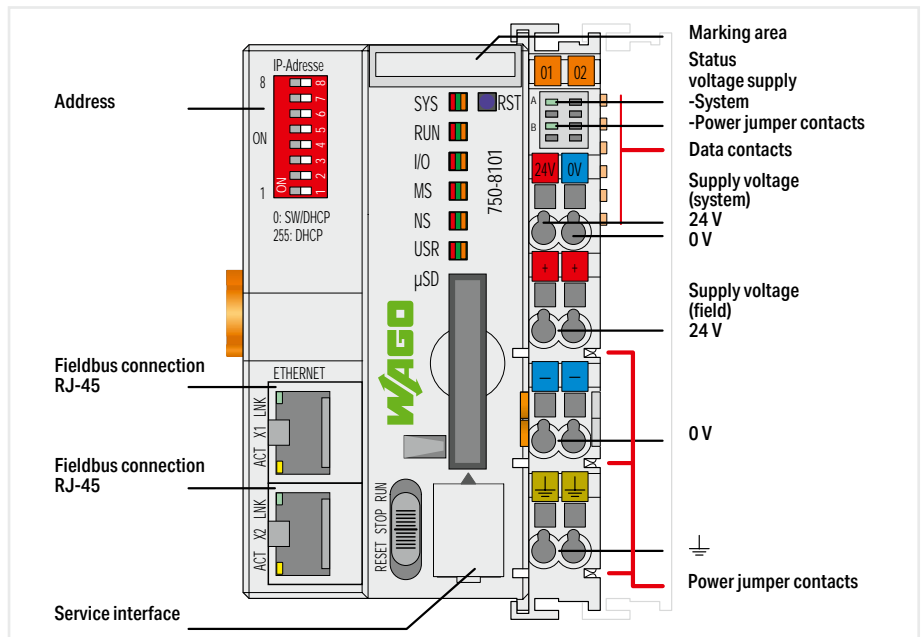

Version	
Item no.	750-8101
Order Text	PFC100; 2ETH

Standard	ext. temperature
750-8101	750-8101/025-000
PFC100; 2ETH	PFC100; 2ETH; T

Technical data	
Communication	Modbus (TCP, UDP); ETHERNET; EtherNet/IP™ Adapter (slave), library for e!RUNTIME, MQTT
ETHERNET protocols	DHCP; DNS; NTP; FTP; FTPS; SNMP; HTTP; HTTPS; SSH
Visualization	Web-Visu
Programming environment	e!COCKPIT (based on CODESYS V3)
CPU	Cortex A8; 600 MHz
Operating system	Real-time Linux 3.18 (with RT-Preempt patch)
Main memory (RAM)/internal memory (flash)/non-volatile memory (hardware)	256 MB / 256 MB / 64 KB
Program memory/data memory/non-volatile memory (software)	12 MB / 12 MB / 64 KB (Program and data memory (dynamically distributed))
Number of modules per node (max.)	250
Input and output process image (internal) max.	1000 words/1000 words
Input and output process image (Modbus®) max.	CODESYS V3: 32000 words/32000 words
Supply voltage (system)	24 VDC (-25 ... +30 %); via pluggable connector (CAGE CLAMP® connection)
Supply voltage (field)	24 VDC (-25 ... +30 %); via power jumper contacts
Input current (typ.) at nominal load (24 V)	550 mA
Total current (system supply)	1700 mA
Ambient temperature (operation)	0 ... +55 °C -20 ... +60 °C
Dimensions W x H x D	(61.5 x 100 x 71.9) mm
Approvals	CE; Marine; OrdLoc/HazLoc; ATEX/IECEX
For data sheet and additional information, see:	

Standard		ext. temperature	
750-8101		750-8101/025-000	
PFC100; 2ETH		PFC100; 2ETH; T	
Technical data			
Communication		Modbus (TCP, UDP); ETHERNET; EtherNet/IP™ Adapter (slave), library for e!RUNTIME, MQTT	
ETHERNET protocols		DHCP; DNS; NTP; FTP; FTPS; SNMP; HTTP; HTTPS; SSH	
Visualization		Web-Visu	
Programming environment		e!COCKPIT (based on CODESYS V3)	
CPU		Cortex A8; 600 MHz	
Operating system		Real-time Linux 3.18 (with RT-Preempt patch)	
Main memory (RAM)/internal memory (flash)/non-volatile memory (hardware)		256 MB / 256 MB / 64 KB	
Program memory/data memory/non-volatile memory (software)		12 MB / 12 MB / 64 KB (Program and data memory (dynamically distributed))	
Number of modules per node (max.)		250	
Input and output process image (internal) max.		1000 words/1000 words	
Input and output process image (Modbus®) max.		CODESYS V3: 32000 words/32000 words	
Supply voltage (system)		24 VDC (-25 ... +30 %); via pluggable connector (CAGE CLAMP® connection)	
Supply voltage (field)		24 VDC (-25 ... +30 %); via power jumper contacts	
Input current (typ.) at nominal load (24 V)		550 mA	
Total current (system supply)		1700 mA	
Ambient temperature (operation)		0 ... +55 °C -20 ... +60 °C	
Dimensions W x H x D		(61.5 x 100 x 71.9) mm	
Approvals		CE; Marine; OrdLoc/HazLoc; ATEX/IECEX	
For data sheet and additional information, see:			

Accessories	
Memory Card SD Micro; 2 GByte	
Memory Card SD Micro; pSLC-NAND; 8 GB; Temperature range: -40 to 90°C	

Item no.	758-879/000-3102	Item no.	758-879/000-3102
	758-879/000-3108		758-879/000-3108

Controller PFC100 ▶ 2 x ETHERNET, RS-232/-485



750-8102

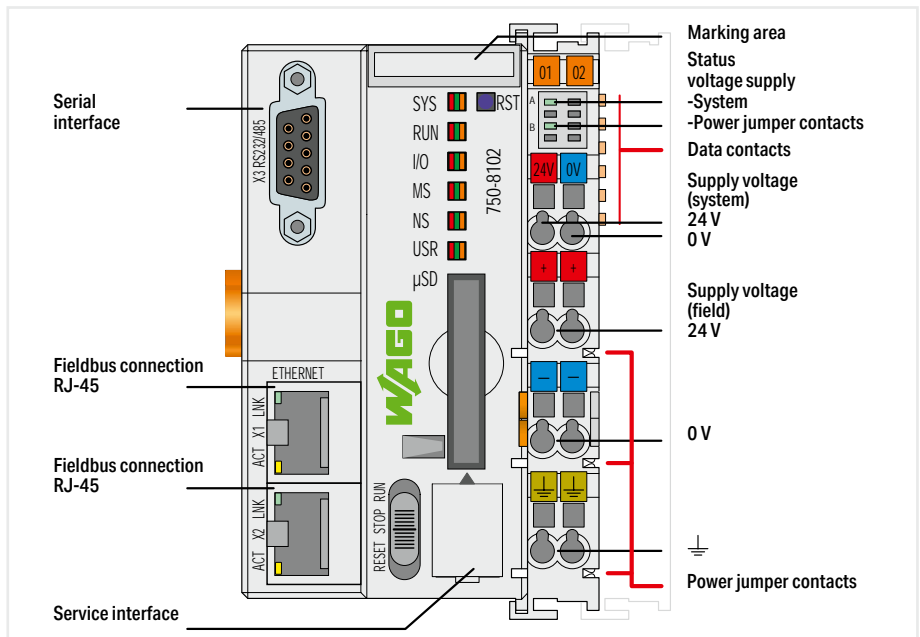

Version	Standard	ext. temperature
Item no.	750-8102	750-8102/025-000
Order Text	PFC100; 2ETH RS	PFC100; 2ETH RS; T

Technical data		
Communication	Modbus (TCP, UDP); ETHERNET; EtherNet/IP™ Adapter (slave), library for e!RUNTIME; Modbus® RTU; RS-232 serial interface; RS-485 interface; MQTT	
ETHERNET protocols	DHCP; DNS; NTP; FTP; FTPS; SNMP; HTTP; HTTPS; SSH	
Visualization	Web-Visu	
Programming environment	e!COCKPIT (based on CODESYS V3)	
CPU	Cortex A8; 600 MHz	
Operating system	Real-time Linux 3.18 (with RT-Preempt patch)	
Main memory (RAM)/internal memory (flash)/non-volatile memory (hardware)	256 MB / 256 MB / 128 KB	
Program memory/data memory/non-volatile memory (software)	12 MB / 12 MB / 128 KB (Program and data memory (dynamically distributed))	
Number of modules per node (max.)	250	
Input and output process image (internal) max.	1000 words/1000 words	
Input and output process image (Modbus®) max.	CODESYS V3: 32000 words/32000 words	
Supply voltage (system)	24 VDC (-25 ... +30 %); via pluggable connector (CAGE CLAMP® connection)	
Supply voltage (field)	24 VDC (-25 ... +30 %); via power jumper contacts	
Input current (typ.) at nominal load (24 V)	550 mA	
Total current (system supply)	1700 mA	
Ambient temperature (operation)	0 ... +55 °C	-20 ... +60 °C
Dimensions W x H x D	(61.5 x 100 x 71.9) mm	
Approvals	CE; Marine; OrdLoc/HazLoc; ATEX/IECEx	
For data sheet and additional information, see:	wago.com/750-8102	

6.1

Accessories	Item no.	Item no.
Memory Card SD Micro; 2 GByte	758-879/000-3102	758-879/000-3102
Memory Card SD Micro; pSLC-NAND; 8 GB; Temperature range: -40 to 90°C	758-879/000-3108	758-879/000-3108

Controller PFC200 ▶ 4 x ETHERNET



750-8210

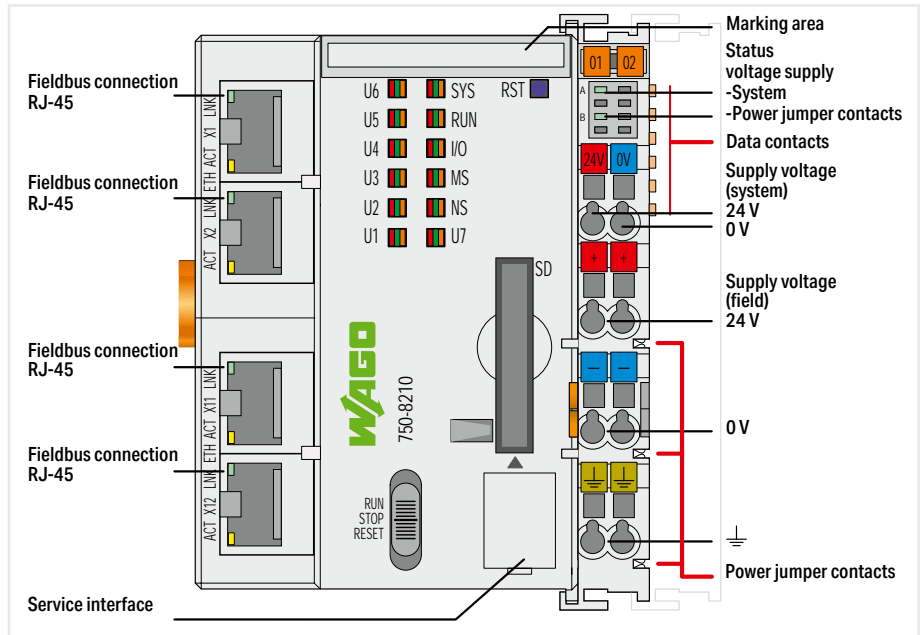

Version	
Item no.	750-8210
Order Text	PFC200; G2; 4ETH

Standard	ext. temperature
750-8210	750-8210/025-000
PFC200; G2; 4ETH	PFC200; G2; 4ETH; T

Technical data
Communication

Modbus TCP master/slave; Modbus (UDP); Modbus (RTU); ETHERNET; EtherNet/IP™ Adapter (slave); EtherNet/IP™ Scanner; EtherCAT® Master; OPC UA Server/Client; OPC UA Pub/Sub (can be installed later); MQTT; BACnet/IP, **requires an additional license**; Telecontrol protocols, **requires an additional license**

ETHERNET protocols
Telecontrol protocols

DHCP; DNS; NTP; FTP; FTPS; SNMP; HTTP; HTTPS; SSH
IEC 60870 (additional license as slave or master); IEC 61850 (additional license as Client or Server); DNP3 (additional license as Slave or Master)

Visualization
Programming environment

Web-Visu
CODESYS V3.5, from firmware release 23; **e!**COCKPIT (based on CODESYS V3), up to firmware release 22; WAGO-I/O-PRO V2.3 (based on CODESYS V2.3), up to firmware release 22

CPU
Operating system

Cortex A8; 1 GHz
Real-time Linux (with RT-Preempt patch)

Main memory (RAM)/internal memory (flash)/non-volatile memory (hardware)

512 MB / 4 GB / 128 KB

Program memory/data memory/non-volatile memory (software)

CODESYS V2: 16 MB / 64 MB / 128 KB; CODESYS V3: 32 MB / 128 MB / 128 KB

Number of modules per node (max.)

250

Input and output process image (internal) max.

1000 words/1000 words

Input and output process image (Modbus®) max.

CODESYS V2: 1000 words/1000 words; CODESYS V3: 32000 words/32000 words

Supply voltage (system)

24 VDC (-25 ... +30 %); via pluggable connector (CAGE CLAMP® connection)

Supply voltage (field)

24 VDC (-25 ... +30 %); via power jumper contacts

Input current (typ.) at nominal load (24 V)

550 mA

Total current (system supply)

1700 mA

Ambient temperature (operation)

0 ... +55 °C | -20 ... +60 °C

Dimensions W x H x D

(78.6 x 100 x 71.9) mm

Approvals

CE; Marine; OrdLoc

For data sheet and additional information, see:

wago.com/750-8210

Product Expansions

Item no.	Item no.
Runtime; BACnet; 300; Single License; Online activation	2759-283/211-1000
Runtime; DNP3 Master; M; Single License; Online activation	2759-2293/211-1000
Runtime; IEC60870 Slave; Single License; Online activation	2759-290/211-1000
Runtime; DNP3 Slave; Single License; Online activation	2759-2290/211-1000
Runtime; IEC60870 Master; M; Single License; Online activation	2759-293/211-1000
Runtime; IEC61850 Client; M; Single License; Online activation	2759-2243/211-1000
Runtime; IEC61850 Server; Single License; Online activation	2759-2240/211-1000

Accessories

Item no.	Item no.
Memory Card SD; SLC-NAND; 2 GByte; Temperature from -40 to 90 °C	758-879/000-001
Memory Card SD; pSLC-NAND; 8 GB; Temperature range: -40 to 90 °C	758-879/000-2108

Controller PFC200 ▶ 2 x ETHERNET, 2 x SFP port



750-8211

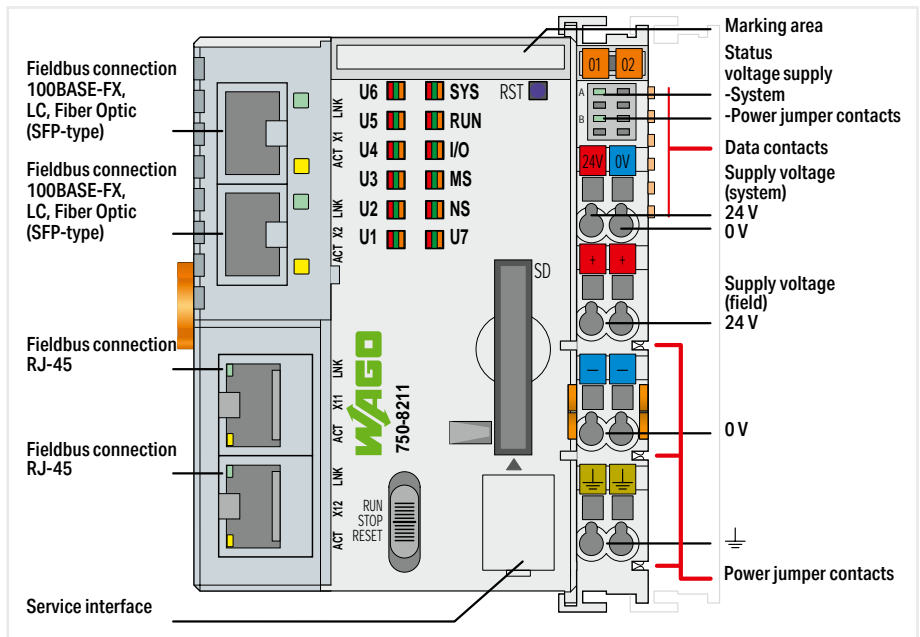

Version
Item no.
Order Text

Standard
750-8211
PFC200; G2; 2ETH 2SFP

Technical data
Communication

Modbus TCP master/slave; Modbus (UDP); Modbus (RTU); ETHERNET; EtherNet/IP™ Adapter (slave); EtherNet/IP™ Scanner; EtherCAT® Master; OPC UA Server/Client; OPC UA Pub/Sub (can be installed later); MQTT; BACnet/IP, **requires an additional license**; Telecontrol protocols, **requires an additional license**

DHCP; DNS; NTP; FTP; FTPS; SNMP; HTTP; HTTPS; SSH

ETHERNET protocols
Telecontrol protocols

IEC 60870 (additional license as slave or master); IEC 61850 (additional license as Client or Server); DNP3 (additional license as Slave or Master)

Visualization
Programming environment

Web-Visu
 CODESYS V3.5, from firmware release 23; **e!COCKPIT** (based on CODESYS V3), up to firmware release 22; WAGO-I/O-PRO V2.3 (based on CODESYS V2.3), up to firmware release 22

CPU
Operating system

Cortex A8; 1 GHz
 Real-time Linux (with RT-Preempt patch)

Main memory (RAM)/internal memory (flash)/non-volatile memory (hardware)
--

512 MB / 4 GB / 128 KB

Program memory/data memory/non-volatile memory (software)

CODESYS V2: 16 MB / 64 MB / 128 KB; CODESYS V3: 32 MB / 128 MB / 128 KB

Number of modules per node (max.)
Input and output process image (internal) max.

250
 1000 words/1000 words

Input and output process image (Modbus®) max.
Supply voltage (system)

CODESYS V2: 1000 words/1000 words; CODESYS V3: 32000 words/32000 words
 24 VDC (-25 ... +30 %); via pluggable connector (CAGE CLAMP® connection)

Supply voltage (field)
Input current (typ.) at nominal load (24 V)

24 VDC (-25 ... +30 %); via power jumper contacts
 550 mA

Total current (system supply)
Ambient temperature (operation)

1700 mA
 0 ... +55 °C

Dimensions W x H x D
Approvals

(78.6 x 100 x 71.9) mm
 CE; Marine; OrdLoc

For data sheet and additional information, see:
Product Expansions

Item no.

Runtime; BACnet; 300; Single License
Runtime; DNP3 Master; M; Single License
Runtime; IEC60870 Slave; Single License
Runtime; DNP3 Slave; Single License
Runtime; IEC60870 Master; M; Single License
Runtime; IEC61850 Client; M; Single License
Runtime; IEC61850 Server; Single License

2759-283/211-1000
2759-2293/211-1000
2759-290/211-1000
2759-2290/211-1000
2759-293/211-1000
2759-2243/211-1000
2759-2240/211-1000

Accessories
Memory Card SD; SLC-NAND; 2 GByte; Temperature from -40 to 90 °C

Item no.
758-879/000-001

SFP Module 100BASE; FX Multi-Mode 1310 nm LC; 2 km; DDM; Extreme; silver-colored
--

852-202

Memory Card SD; pSLC-NAND; 8 GB; Temperature range: -40 to 90°C

758-879/000-2108

6.1

Controller PFC200 ▶ 2 x ETHERNET, RS-232/-485



750-8212

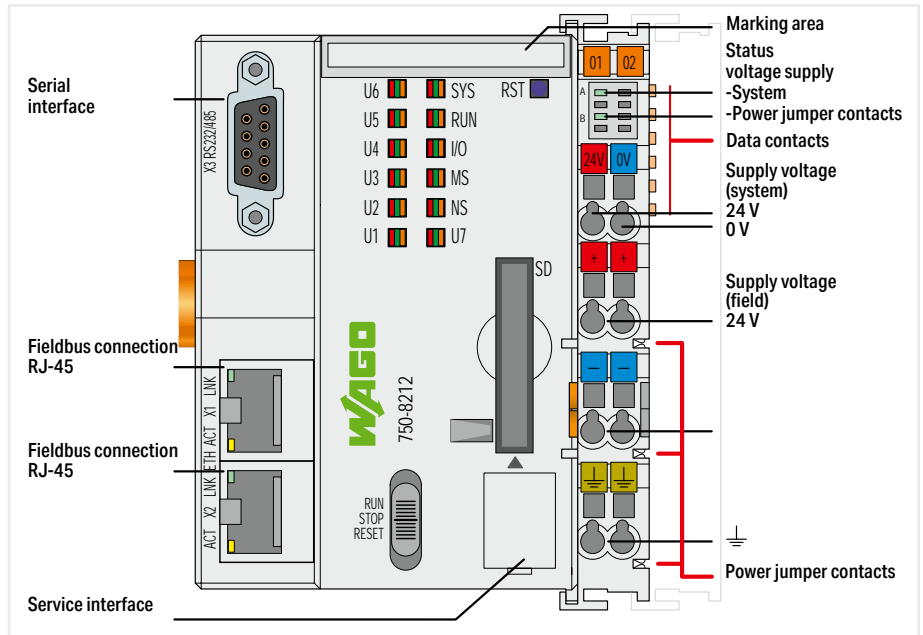

Version	Standard	ext. temperature	Telecontrol technology; ext. temperature	Telecontrol technology; ext. temperature; ECO
Item no.	750-8212	750-8212/025-000	750-8212/025-001	750-8212/025-002
Order Text	PFC200; G2; 2ETH RS	PFC200; G2; 2ETH RS; T	PFC200; G2; 2ETH RS; Tele; T	PFC200; G2; 2ETH RS; Tele; T; ECO

Technical data				
Communication	Modbus TCP master/slave; Modbus (UDP); Modbus (RTU); ETHERNET; EtherNet/IP™ Adapter (slave); EtherNet/IP™ Scanner; EtherCAT® Master; OPC UA Server/Client; OPC UA Pub/Sub (can be installed later); MQTT; RS-232 serial interface; RS-485 interface; BACnet/IP, requires an additional license ; Telecontrol protocols, requires an additional license		Modbus TCP master/slave; Modbus (UDP); Modbus (RTU); ETHERNET; EtherNet/IP™ Adapter (slave); EtherNet/IP™ Scanner; EtherCAT® Master; OPC UA Server/Client; OPC UA Pub/Sub (can be installed later); MQTT; Telecontrol protocols; RS-232 serial interface; RS-485 interface; BACnet/IP, requires an additional license	
ETHERNET protocols	DHCP; DNS; NTP; FTP; FTPS; SNMP; HTTP; HTTPS; SSH			
Telecontrol protocols	IEC 60870 (additional license as slave or master); IEC 61850 (additional license as Client or Server); DNP3 (additional license as Slave or Master)		IEC 60870; IEC 61850; DNP3	
Visualization	Web-Visu			
Programming environment	CODESYS V3.5, from firmware release 23; e!COCKPIT (based on CODESYS V3), up to firmware release 22; WAGO-I/O-PRO V2.3 (based on CODESYS V2.3), up to firmware release 22			
CPU	Cortex A8; 1 GHz			
Operating system	Real-time Linux (with RT-Preempt patch)			
Main memory (RAM)/internal memory (flash)/non-volatile memory (hardware)	512 MB / 4 GB / 128 KB			
Program memory/data memory/non-volatile memory (software)	CODESYS V2: 16 MB / 64 MB / 128 KB; CODESYS V3: 32 MB / 128 MB / 128 KB			
Number of modules per node (max.)	250		6	
Input and output process image (internal) max.	1000 words/1000 words			
Input and output process image (Modbus®) max.	CODESYS V2: 1000 words/1000 words; CODESYS V3: 32000 words/32000 words			
Supply voltage (system)	24 VDC (-25 ... +30 %); via pluggable connector (CAGE CLAMP® connection)			
Supply voltage (field)	24 VDC (-25 ... +30 %); via power jumper contacts			
Input current (typ.) at nominal load (24 V)	550 mA			
Total current (system supply)	1700 mA			
Ambient temperature (operation)	0 ... +55 °C		-20 ... +60 °C	
Dimensions W x H x D	(78.6 x 100 x 71.9) mm			
Approvals	CE; Marine; OrdLoc/HazLoc; ATEX/IECEx			
For data sheet and additional information, see:	wago.com/750-8212			

Product Expansions	Item no.	Item no.	Item no.	Item no.
Runtime; BACnet; 300; Single License	2759-283/211-1000	2759-283/211-1000	2759-283/211-1000	2759-283/211-1000
Runtime; DNP3 Master; M; Single License	2759-2293/211-1000	2759-2293/211-1000	-	-
Runtime; IEC60870 Slave; Single License	2759-290/211-1000	2759-290/211-1000	-	-
Runtime; DNP3 Slave; Single License	2759-2290/211-1000	2759-2290/211-1000	-	-
Runtime; IEC60870 Master; M; Single License	2759-293/211-1000	2759-293/211-1000	-	-
Runtime; IEC61850 Client; M; Single License	2759-2243/211-1000	2759-2243/211-1000	-	-
Runtime; IEC61850 Server; Single License	2759-2240/211-1000	2759-2240/211-1000	-	-
Accessories	Item no.	Item no.	Item no.	Item no.
Memory Card SD; SLC-NAND; 2 GByte; Temperature from -40 to 90 °C	758-879/000-001	758-879/000-001	758-879/000-001	758-879/000-001
Memory Card SD; pSLC-NAND; 8 GB; Temperature range: -40 to 90°C	758-879/000-2108	758-879/000-2108	758-879/000-2108	758-879/000-2108

Controller PFC200 ▶ 2 x ETHERNET, RS-232/-485, BACnet/IP



750-8212/000-100

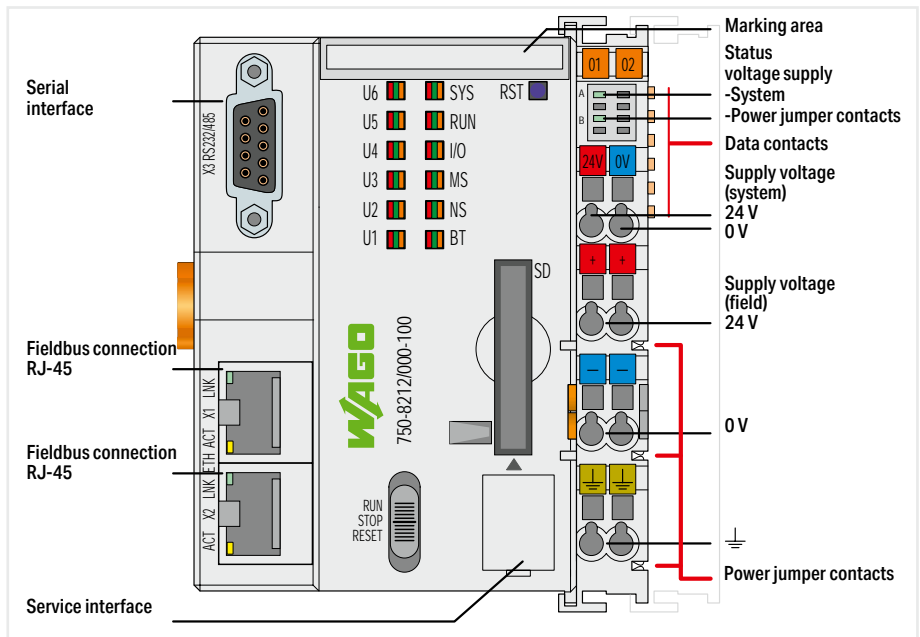

Version	BACnet/IP
Item no.	750-8212/000-100
Order Text	PFC200; G2; 2ETH RS; BACnet/IP

Technical data	
Communication	BACnet/IP; Modbus TCP master/slave; Modbus (UDP); Modbus (RTU); ETHERNET; EtherNet/IP™ Adapter (slave); EtherNet/IP™ Scanner; EtherCAT® Master; OPC UA Server/Client; OPC UA Pub/Sub (can be installed later); MQTT; RS-232 serial interface; RS-485 interface; Telecontrol protocols, requires an additional license
ETHERNET protocols	DHCP; DNS; NTP; FTP; FTPS; SNMP; HTTP; HTTPS; SSH
Telecontrol protocols	IEC 60870 (additional license as slave or master); IEC 61850 (additional license as Client or Server); DNP3 (additional license as Slave or Master)
Device-specific	BACnet/IP protocol: ISO 16484-5; BACnet device profiles: B-B-C (BACnet Building Controller); BACnet revision: 14
Visualization	Web-Visu
Programming environment	CODESYS V3.5, from firmware release 23; e!COCKPIT (based on CODESYS V3), up to firmware release 22
CPU	Cortex A8; 1 GHz
Operating system	Real-time Linux (with RT-Preempt patch)
Main memory (RAM)/internal memory (flash)/non-volatile memory (hardware)	512 MB / 4 GB / 128 KB
Program memory/data memory/non-volatile memory (software)	CODESYS V3: 32 MB / 128 MB / 128 KB
Number of modules per node (max.)	250
Input and output process image (internal) max.	1000 words/1000 words
Input and output process image (Modbus®) max.	CODESYS V3: 32000 words/32000 words
Supply voltage (system)	24 VDC (-25 ... +30 %); via pluggable connector (CAGE CLAMP® connection)
Supply voltage (field)	24 VDC (-25 ... +30 %); via power jumper contacts
Input current (typ.) at nominal load (24 V)	550 mA
Total current (system supply)	1700 mA
Ambient temperature (operation)	0 ... +55 °C
Dimensions W x H x D	(78.6 x 100 x 71.9) mm
Approvals	CE; Marine; OrdLoc/HazLoc; ATEX/IECEx
Approvals (pending)	BACnet approvals: WSPCert certification; BTL listing
For data sheet and additional information, see:	wago.com/750-8212/000-100

Product Expansions	Item no.
Runtime; DNP3 Master; M; Single License; Online activation	2759-2293/211-1000
Runtime; IEC60870 Slave; Single License; Online activation	2759-290/211-1000
Runtime; DNP3 Slave; Single License; Online activation	2759-2290/211-1000
Runtime; IEC60870 Master; M; Single License; Online activation	2759-293/211-1000
Runtime; IEC61850 Client; M; Single License; Online activation	2759-2243/211-1000
Runtime; IEC61850 Server; Single License; Online activation	2759-2240/211-1000
Accessories	Item no.
Memory Card SD; SLC-NAND; 2 GByte; Temperature from -40 to 90 °C	758-879/000-001
Memory Card SD; pSLC-NAND; 8 GB; Temperature range: -40 to 90°C	758-879/000-2108

6.1

Controller PFC200 ▶ 2 x ETHERNET, CAN, CANopen



750-8213

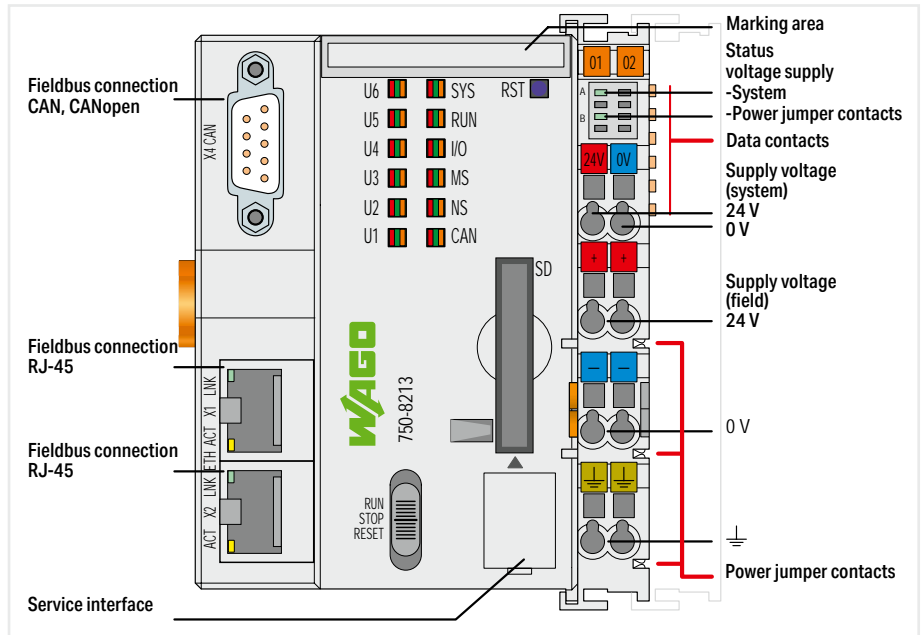

Version	
Item no.	
Order Text	

Standard	
750-8213	
PFC200; G2; 2ETH CAN	

Technical data	
Communication	

CANopen; Modbus TCP master/slave; Modbus (UDP); ETHERNET; EtherNet/IP™ Adapter (slave); EtherNet/IP™ Scanner; EtherCAT® Master; OPC UA Server/Client; OPC UA Pub/Sub (can be installed later); MQTT; BACnet/IP, **requires an additional license**; Telecontrol protocols, **requires an additional license**

ETHERNET protocols	
Telecontrol protocols	

DHCP; DNS; NTP; FTP; FTPS; SNMP; HTTP; HTTPS; SSH
IEC 60870 (additional license as slave or master); IEC 61850 (additional license as Client or Server); DNP3 (additional license as Slave or Master)

Visualization	
Programming environment	

Web-Visu
CODESYS V3.5, from firmware release 23; **e!COCKPIT** (based on CODESYS V3), up to firmware release 22; WAGO-I/O-PRO V2.3 (based on CODESYS V2.3), up to firmware release 22

CPU	
Operating system	

Cortex A8; 1 GHz
Real-time Linux (with RT-Preempt patch)

Main memory (RAM)/internal memory (flash)/non-volatile memory (hardware)	
--	--

512 MB / 4 GB / 128 KB

Program memory/data memory/non-volatile memory (software)	
---	--

CODESYS V2: 16 MB / 64 MB / 128 KB; CODESYS V3: 32 MB / 128 MB / 128 KB

Number of modules per node (max.)	
-----------------------------------	--

250

Input and output process image (internal) max.	
--	--

1000 words/1000 words

Input and output process image (Modbus®) max.	
---	--

CODESYS V2: 1000 words/1000 words; CODESYS V3: 32000 words/32000 words

Input and output process image (CAN) max.	
---	--

2000 words/2000 words

Supply voltage (system)	
-------------------------	--

24 VDC (-25 ... +30 %); via pluggable connector (CAGE CLAMP® connection)

Supply voltage (field)	
------------------------	--

24 VDC (-25 ... +30 %); via power jumper contacts

Input current (typ.) at nominal load (24 V)	
---	--

550 mA

Total current (system supply)	
-------------------------------	--

1700 mA

Ambient temperature (operation)	
---------------------------------	--

0 ... +55 °C

Dimensions W x H x D	
----------------------	--

(78.6 x 100 x 71.9) mm

Approvals	
-----------	--

CE; Marine; OrdLoc/HazLoc; ATEX/IECEx

For data sheet and additional information, see:

wago.com/750-8213

Product Expansions	
--------------------	--

Item no.	
----------	--

Runtime; BACnet; 300; Single License; Online activation

2759-283/211-1000

Runtime; DNP3 Master; M; Single License; Online activation

2759-2293/211-1000

Runtime; IEC60870 Slave; Single License; Online activation

2759-290/211-1000

Runtime; DNP3 Slave; Single License; Online activation

2759-2290/211-1000

Runtime; IEC60870 Master; M; Single License; Online activation

2759-293/211-1000

Runtime; IEC61850 Client; M; Single License; Online activation

2759-2243/211-1000

Runtime; IEC61850 Server; Single License; Online activation

2759-2240/211-1000

Accessories	
-------------	--

Item no.	
----------	--

Memory Card SD; SLC-NAND; 2 GByte; Temperature from -40 to 90 °C

758-879/000-001

Memory Card SD; pSLC-NAND; 8 GB; Temperature range: -40 to 90°C

758-879/000-2108

Controller PFC200 ▶ 2 x ETHERNET, RS-232/-485, CAN, CANopen



750-8214

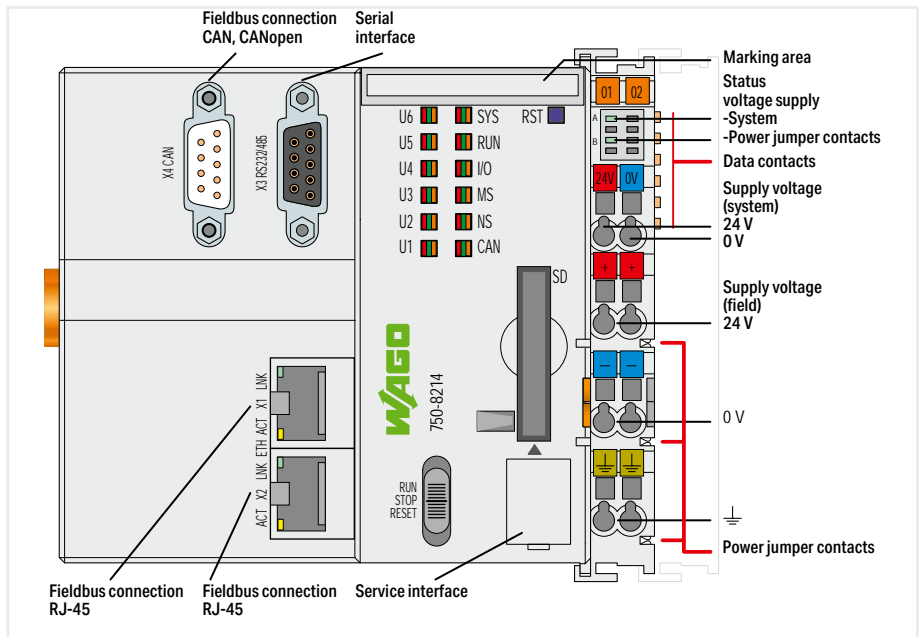

Version
Item no.
Order Text

Standard
750-8214
PFC200; G2; 2ETH RS CAN

Technical data
Communication

CANopen; Modbus TCP master/slave; Modbus (UDP); Modbus (RTU); ETHERNET; EtherNet/IP™ Adapter (slave); EtherNet/IP™ Scanner; EtherCAT® Master; OPC UA Server/Client; OPC UA Pub/Sub (can be installed later); MQTT; RS-232 serial interface; RS-485 interface; Telecontrol protocols, **requires an additional license**

ETHERNET protocols
Telecontrol protocols

DHCP; DNS; NTP; FTP; FTPS; SNMP; HTTP; HTTPS; SSH

Visualization
Programming environment

IEC 60870 (additional license as slave or master); IEC 61850 (additional license as Client or Server); DNP3 (additional license as Slave or Master)

Web-Visu
CODESYS V3.5, from firmware release 23; **e!COCKPIT** (based on CODESYS V3), up to firmware release 22; WAGO-I/O-PRO V2.3 (based on CODESYS V2.3), up to firmware release 22

CPU
Operating system

Cortex A8; 1 GHz
Real-time Linux (with RT-Preempt patch)

Main memory (RAM)/internal memory (flash)/non-volatile memory (hardware)
--

512 MB / 4 GB / 128 KB

Program memory/data memory/non-volatile memory (software)

CODESYS V2: 16 MB / 64 MB / 128 KB; CODESYS V3: 32 MB / 128 MB / 128 KB

Number of modules per node (max.)

250

Input and output process image (internal) max.
--

1000 words/1000 words

Input and output process image (Modbus®) max.

CODESYS V2: 1000 words/1000 words; CODESYS V3: 32000 words/32000 words

Input and output process image (CAN) max.

2000 words/2000 words

Supply voltage (system)

24 VDC (-25 ... +30 %); via pluggable connector (CAGE CLAMP® connection)

Supply voltage (field)

24 VDC (-25 ... +30 %); via power jumper contacts

Input current (typ.) at nominal load (24 V)

550 mA

Total current (system supply)

1700 mA

Ambient temperature (operation)

0 ... +55 °C

Dimensions W x H x D

(112 x 100 x 71.9) mm

Approvals

CE; Marine; OrdLoc/HazLoc; ATEX/IECEX

For data sheet and additional information, see:

wago.com/750-8214

Product Expansions
Runtime; DNP3 Master; M; Single License; Online activation

Item no.
2759-2293/211-1000

Runtime; IEC60870 Slave; Single License; Online activation
--

2759-290/211-1000

Runtime; DNP3 Slave; Single License; Online activation
--

2759-2290/211-1000

Runtime; IEC60870 Master; M; Single License; Online activation
--

2759-293/211-1000

Runtime; IEC61850 Client; M; Single License; Online activation
--

2759-2243/211-1000

Runtime; IEC61850 Server; Single License; Online activation

2759-2240/211-1000

Accessories
Memory Card SD; SLC-NAND; 2 GByte; Temperature from -40 to 90 °C

Item no.
758-879/000-001

Memory Card SD; pSLC-NAND; 8 GB; Temperature range: -40 to 90°C

758-879/000-2108

6.1

Controller PFC200 ▶ 4 x ETHERNET, CAN, CANopen, USB



750-8215

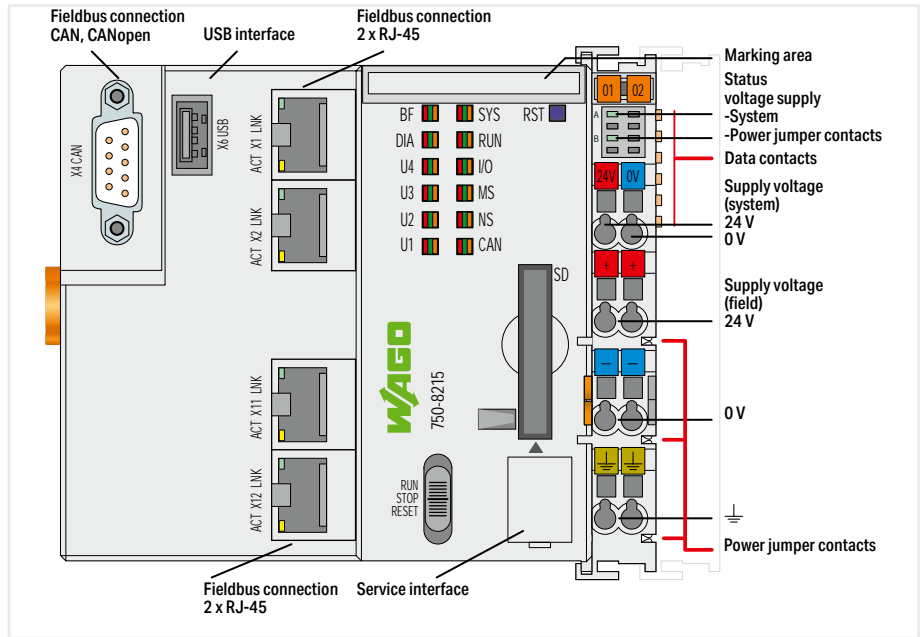

Version	Standard
Item no.	750-8215
Order Text	PFC200; G2; 4ETH CAN USB
Technical data	
Communication	PROFINET RT; CANopen; Modbus TCP master/slave; Modbus (UDP); ETHERNET; EtherNet/IP™ Adapter (slave); EtherNet/IP™ Scanner; EtherCAT® Master; OPC UA Server/Client; OPC UA Pub/Sub (can be installed later); MQTT; Telecontrol protocols, requires an additional license
ETHERNET protocols	DHCP; DNS; NTP; FTP; FTPS; SNMP; HTTP; HTTPS; SSH
Telecontrol protocols	IEC 60870 (additional license as slave or master); IEC 61850 (additional license as Client or Server); DNP3 (additional license as Slave or Master)
Device-specific	PROFINET IO features: PROFINET IO V2.3; Media redundancy (MRP); Shared device
Visualization	Web-Visu
Programming environment	CODESYS V3.5, from firmware release 23; e!COCKPIT (based on CODESYS V3), up to firmware release 22
CPU	Cortex A8; 1 GHz
Operating system	Real-time Linux (with RT-Preempt patch)
Main memory (RAM)/internal memory (flash)/non-volatile memory (hardware)	512 MB / 4 GB / 128 KB
Program memory/data memory/non-volatile memory (software)	CODESYS V3: 32 MB / 128 MB / 128 KB
Number of modules per node (max.)	250
Input and output process image (internal) max.	1000 words/1000 words
Input and output process image (Modbus®) max.	CODESYS V3: 32000 words/32000 words
Input and output process image (CAN) max.	2000 words/2000 words
Input and output process image (PROFINET) max.	1024 bytes/1024 bytes
Supply voltage (system)	24 VDC (-25 ... +30 %); via pluggable connector (CAGE CLAMP® connection)
Supply voltage (field)	24 VDC (-25 ... +30 %); via power jumper contacts
Input current (typ.) at nominal load (24 V)	550 mA
Total current (system supply)	1700 mA
Ambient temperature (operation)	0 ... +55 °C
Dimensions W x H x D	(112 x 100 x 71.9) mm
Approvals	CE; Marine; OrdLoc/HazLoc; ATEX/IECEx
For data sheet and additional information, see:	wago.com/750-8215
Product Expansions	Item no.
Runtime; DNP3 Master; M; Single License; Online activation	2759-2293/211-1000
Runtime; IEC60870 Slave; Single License; Online activation	2759-290/211-1000
Runtime; DNP3 Slave; Single License; Online activation	2759-2290/211-1000
Runtime; IEC60870 Master; M; Single License; Online activation	2759-293/211-1000
Runtime; IEC61850 Client; M; Single License; Online activation	2759-2243/211-1000
Runtime; IEC61850 Server; Single License; Online activation	2759-2240/211-1000
Accessories	Item no.
Memory Card SD; SLC-NAND; 2 GByte; Temperature from -40 to 90 °C	758-879/000-001
Memory Card SD; pSLC-NAND; 8 GB; Temperature range: -40 to 90°C	758-879/000-2108

Controller PFC200 ▶ 2 x ETHERNET, RS-232/-485, CAN, CANopen, PROFIBUS slave



750-8216

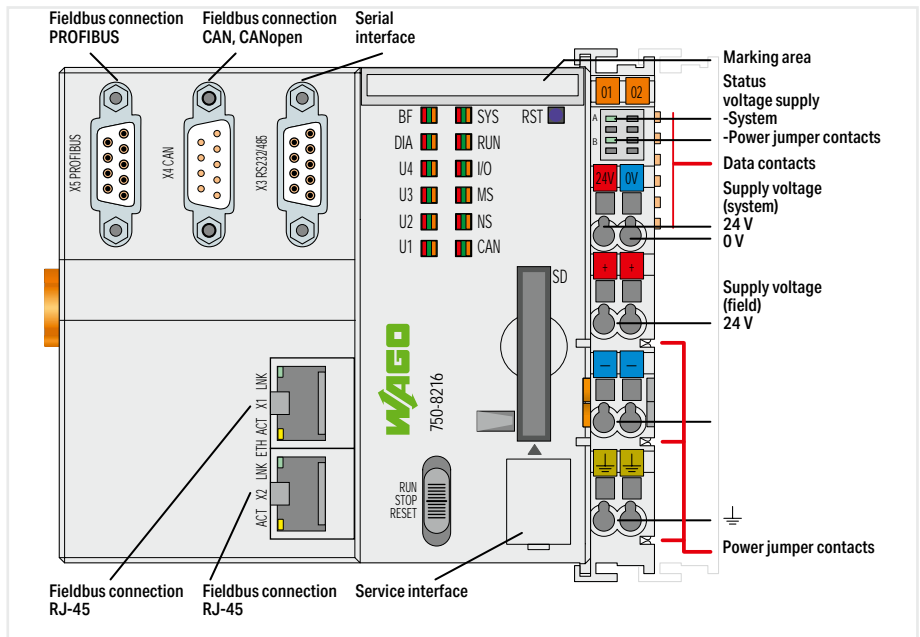

Version	Standard	ext. temperature	Telecontrol technology; ext. temperature
Item no.	750-8216	750-8216/025-000	750-8216/025-001
Order Text	PFC200; G2; 2ETH RS CAN DPS	PFC200; G2; 2ETH RS CAN DPS; T	PFC200; G2; 2ETH RS CAN DPS; Tele; T

Technical data			
Communication	PROFIBUS; CANopen; Modbus TCP master/slave; Modbus (UDP); Modbus (RTU); ETHERNET; EtherNet/IP™ Adapter (slave); EtherNet/IP™ Scanner; EtherCAT® Master; OPC UA Server/Client; OPC UA Pub/Sub (can be installed later); MQTT; RS-232 serial interface; RS-485 interface; BACnet/IP, requires an additional license ; Telecontrol protocols, requires an additional license		PROFIBUS; CANopen; Modbus TCP master/slave; Modbus (UDP); Modbus (RTU); ETHERNET; EtherNet/IP™ Adapter (slave); EtherNet/IP™ Scanner; EtherCAT® Master; OPC UA Server/Client; OPC UA Pub/Sub (can be installed later); MQTT; Telecontrol protocols; RS-232 serial interface; RS-485 interface; BACnet/IP, requires an additional license

ETHERNET protocols	DHCP; DNS; NTP; FTP; FTPS; SNMP; HTTP; HTTPS; SSH	
Telecontrol protocols	IEC 60870 (additional license as slave or master); IEC 61850 (additional license as Client or Server); DNP3 (additional license as Slave or Master)	IEC 60870; IEC 61850; DNP3
Visualization	Web-Visu	
Programming environment	CODESYS V3.5, from firmware release 23; e!COCKPIT (based on CODESYS V3), up to firmware release 22; WAGO-I/O-PRO V2.3 (based on CODESYS V2.3), up to firmware release 22	

CPU	Cortex A8; 1 GHz	
Operating system	Real-time Linux (with RT-Preempt patch)	
Main memory (RAM)/internal memory (flash)/non-volatile memory (hardware)	512 MB / 4 GB / 128 KB	
Program memory/data memory/non-volatile memory (software)	CODESYS V2: 16 MB / 64 MB / 128 KB; CODESYS V3: 32 MB / 128 MB / 128 KB	
Number of modules per node (max.)	250	
Input and output process image (internal) max.	1000 words/1000 words	
Input and output process image (Modbus®) max.	CODESYS V2: 1000 words/1000 words; CODESYS V3: 32000 words/32000 words	
Input and output process image (PROFIBUS) max.	244 bytes/244 bytes	
Input and output process image (CAN) max.	2000 words/2000 words	
Supply voltage (system)	24 VDC (-25 ... +30 %); via pluggable connector (CAGE CLAMP® connection)	
Supply voltage (field)	24 VDC (-25 ... +30 %); via power jumper contacts	
Input current (typ.) at nominal load (24 V)	550 mA	
Total current (system supply)	1700 mA	
Ambient temperature (operation)	0 ... +55 °C	-20 ... +60 °C
Dimensions W x H x D	(112 x 100 x 71.9) mm	

Approvals: CE, Marine, OrdLoc/HazLoc, ATEX/IECEx
wago.com/750-8216

For data sheet and additional information, see:			
Product Expansions	Item no.	Item no.	Item no.
Runtime; BACnet; 300; Single License	2759-283/211-1000	2759-283/211-1000	2759-283/211-1000
Runtime; DNP3 Master; M; Single License	2759-2293/211-1000	2759-2293/211-1000	-
Runtime; IEC60870 Slave; Single License	2759-290/211-1000	2759-290/211-1000	-
Runtime; DNP3 Slave; Single License	2759-2290/211-1000	2759-2290/211-1000	-
Runtime; IEC60870 Master; M; Single License	2759-293/211-1000	2759-293/211-1000	-
Runtime; IEC61850 Client; M; Single License	2759-2243/211-1000	2759-2243/211-1000	-
Runtime; IEC61850 Server; Single License	2759-2240/211-1000	2759-2240/211-1000	-
Accessories	Item no.	Item no.	Item no.
Memory Card SD; SLC-NAND; 2 GB	758-879/000-001	758-879/000-001	758-879/000-001
Memory Card SD; pSLC-NAND; 8 GB	758-879/000-2108	758-879/000-2108	758-879/000-2108

6.1

Controller PFC200 ▶ 2 x ETHERNET, RS-232/-485, mobile radio module 4G



750-8217

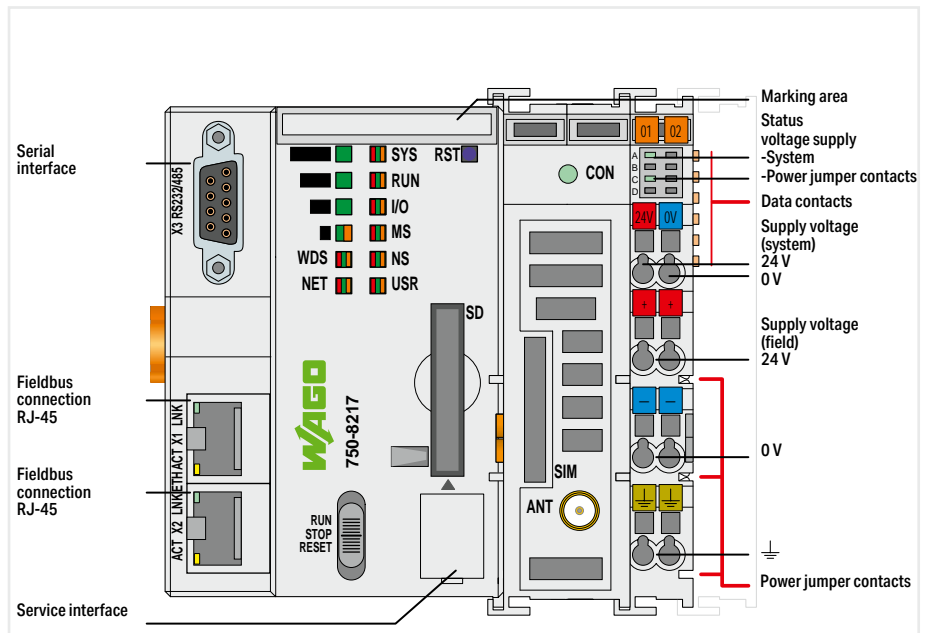

Version	Standard	ext. temperature
Item no.	750-8217	750-8217/025-000
Order Text	PFC200; 2ETH RS 4G; EU	PFC200; 2ETH RS 4G; EU; T

Technical data		
Communication	Modbus (TCP, UDP); ETHERNET; EtherNet/IP™ Adapter (slave), library for <i>e!RUNTIME</i> ; Modbus® RTU; RS-232 serial interface; RS-485 interface; MQTT; BACnet/IP, requires an additional license ; EtherCAT® master (requires an additional license); Telecontrol protocols, requires an additional license	
ETHERNET protocols	DHCP; DNS; NTP; FTP; FTPS; SNMP; HTTP; HTTPS; SSH	
Telecontrol protocols	IEC 60870 (additional license as slave or master); IEC 61850 (additional license as Client or Server); DNP3 (additional license as Slave or Master)	
Radio technology	GSM/UMTS/LTE	
Frequency band	GSM dual band (B3; B8); E-UTRA bands (B1; B3; B5; B7; B8; B20; B38; B40; B41)	
Services	SMS (bidirectional); GPRS connection to Internet	
Security encryption	OpenVPN, IPsec, firewall	
Visualization	Web-Visu	
Programming environment	<i>e!COCKPIT</i> (based on CODESYS V3)	
CPU	Cortex A8; 1 GHz	
Operating system	Real-time Linux (with RT-Preempt patch)	
Main memory (RAM)/internal memory (flash)/non-volatile memory (hardware)	512 MB / 4 GB / 128 KB	
Program memory/data memory/non-volatile memory (software)	32 MB / 128 MB / 128 KB	
Number of modules per node (max.)	250	
Input and output process image (internal) max.	1000 words/1000 words	
Input and output process image (Modbus®) max.	CODESYS V3: 32000 words/32000 words	
Supply voltage (system)	24 VDC (-25 ... +30 %); via pluggable connector (CAGE CLAMP® connection)	
Supply voltage (field)	24 VDC (-25 ... +30 %); via power jumper contacts	
Input current (typ.) at nominal load (24 V)	550 mA	
Total current (system supply)	700 mA	
Ambient temperature (operation)	0 ... +55 °C	-20 ... +60 °C
Dimensions W x H x D	(102.5 x 100 x 71.9) mm	
Approvals	CE; Marine	
For data sheet and additional information, see:	wago.com/750-8217	

Product Expansions	Item no.	Item no.
Runtime; BACnet; 300; Single License	2759-283/211-1000	2759-283/211-1000
Runtime; DNP3 Master; M; Single License	2759-2293/211-1000	2759-2293/211-1000
Runtime; IEC60870 Slave; Single License	2759-290/211-1000	2759-290/211-1000
Runtime; DNP3 Slave; Single License	2759-2290/211-1000	2759-2290/211-1000
Runtime; IEC60870 Master; M; Single License	2759-293/211-1000	2759-293/211-1000
Runtime; IEC61850 Client; M; Single License	2759-2243/211-1000	2759-2243/211-1000
Runtime; IEC61850 Server; Single License	2759-2240/211-1000	2759-2240/211-1000
Accessories	Item no.	Item no.
Memory Card SD; SLC-NAND; 2 GByte; Temperature from -40 to 90 °C	758-879/000-001	758-879/000-001
Memory Card SD; pSLC-NAND; 8 GB; Temperature range: -40 to 90 °C	758-879/000-2108	758-879/000-2108
Magnetic foot antenna; with 2.5m cable and SMA plug; GSM/ UMTS/ LTE/ Bluetooth®/ WLAN; 698-960, 1710-6000 MHz	758-975	758-975

Controller PFC200 ▶ 2 x ETHERNET, RS-232/-485, mobile radio module 4G; global variant



750-8217

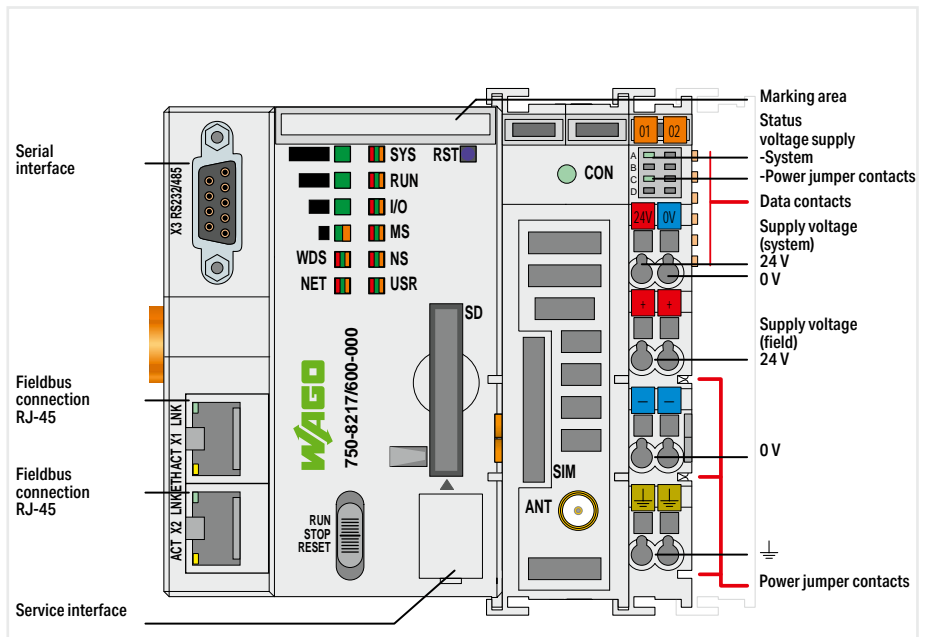

Version	Standard	ext. temperature
Item no.	750-8217/600-000	750-8217/625-000
Order Text	PFC200; 2ETH RS 4G; Global	PFC200; 2ETH RS 4G; Global; T

Technical data		
Communication	Modbus (TCP, UDP); ETHERNET; EtherNet/IP™ Adapter (slave), library for <i>e!RUNTIME</i> ; Modbus® RTU; RS-232 serial interface; RS-485 interface; MQTT; BACnet/IP, requires an additional license ; EtherCAT® master (requires an additional license); Telecontrol protocols, requires an additional license	
ETHERNET protocols	DHCP; DNS; NTP; FTP; FTPS; SNMP; HTTP; HTTPS; SSH	
Telecontrol protocols	IEC 60870 (additional license as slave or master); IEC 61850 (additional license as Client or Server); DNP3 (additional license as Slave or Master)	
Radio technology	GSM/Edge/UMTS/HSPA+; LTE	
Frequency band	GSM: B2/B3/B5/B8; WCDMA: B1/B2/B4/B5/B6/B8/B19; LTE-FDD: B1/B2/B3/B4/B5/B7/B8/B12/B13/B18/ B19/B20/B25/ B26/B28; LTE-TDD: B38/B39/B40/B41	
Services	GPRS connection to Internet	
Security encryption	OpenVPN, IPsec, firewall	
Visualization	Web-Visu	
Programming environment	e!COCKPIT (based on CODESYS V3)	
CPU	Cortex A8; 1 GHz	
Operating system	Real-time Linux (with RT-Preempt patch)	
Main memory (RAM)/internal memory (flash)/non-volatile memory (hardware)	512 MB / 4 GB / 128 KB	
Program memory/data memory/non-volatile memory (software)	32 MB / 128 MB / 128 KB	
Number of modules per node (max.)	250	
Input and output process image (internal) max.	1000 words/1000 words	
Input and output process image (Modbus®) max.	CODESYS V3: 32000 words/32000 words	
Supply voltage (system)	24 VSELV/PELV DC (-25 ... +30 %); via pluggable connector (CAGE CLAMP® connection)	
Supply voltage (field)	24 VSELV/PELV DC (-25 ... +30 %); via power jumper contacts	
Input current (typ.) at nominal load (24 V)	550 mA	
Total current (system supply)	700 mA	
Ambient temperature (operation)	0 ... +55 °C	-20 ... +60 °C
Dimensions W x H x D	(102.5 x 100 x 71.9) mm	
Approvals	CE; Marine; OrdLoc	
For data sheet and additional information, see:	wago.com/750-8217/600-000	

Product Expansions	Item no.	Item no.
Runtime; BACnet; 300; Single License	2759-283/211-1000	2759-283/211-1000
Runtime; DNP3 Master; M; Single License	2759-2293/211-1000	2759-2293/211-1000
Runtime; IEC60870 Slave; Single License	2759-290/211-1000	2759-290/211-1000
Runtime; DNP3 Slave; Single License	2759-2290/211-1000	2759-2290/211-1000
Runtime; IEC60870 Master; M; Single License	2759-293/211-1000	2759-293/211-1000
Runtime; IEC61850 Client; M; Single License	2759-2243/211-1000	2759-2243/211-1000
Runtime; IEC61850 Server; Single License	2759-2240/211-1000	2759-2240/211-1000
Accessories	Item no.	Item no.
Memory Card SD; SLC-NAND; 2 GByte; Temperature from -40 to 90 °C	758-879/000-001	758-879/000-001
Memory Card SD; pSLC-NAND; 8 GB; Temperature range: -40 to 90°C	758-879/000-2108	758-879/000-2108
Magnetic foot antenna; with 2.5m cable and SMA plug; GSM/ UMTS/ LTE/ Bluetooth®/ WLAN; 698-960, 1710-6000 MHz	758-975	758-975

6.1

Controller PFC200 ▶ 2 x ETHERNET, RS-232/-485, CAN, CANopen, PROFIBUS master

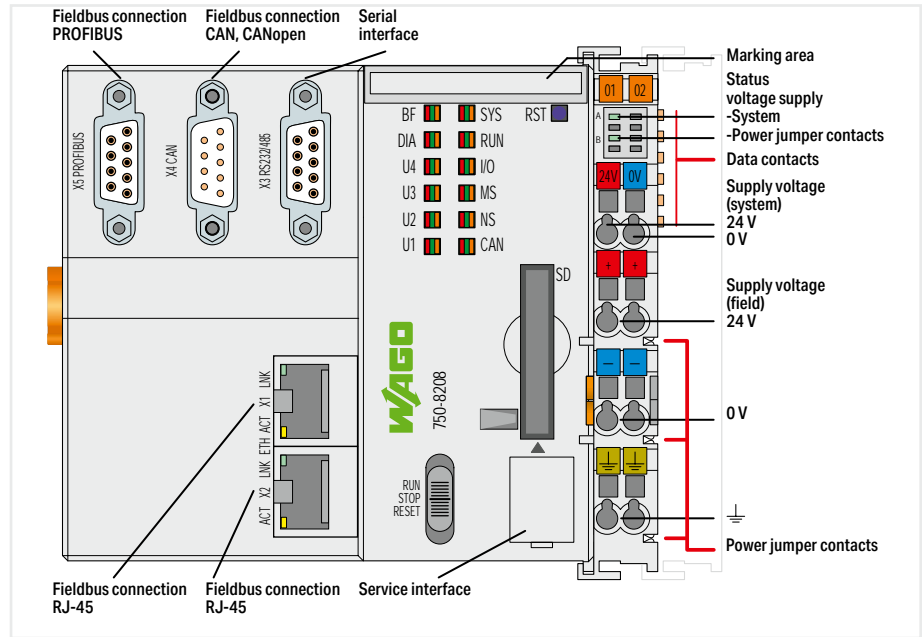

750-8208

Version	Standard	ext. temperature	Telecontrol technology; ext. temperature
Item no.	750-8208	750-8208/025-000	750-8208/025-001
Order Text	PFC200; 2ETH RS CAN DPM	PFC200; 2ETH RS CAN DPM; T	PFC200; 2ETH RS CAN DPM; Tele; T

Technical data			
Communication	PROFIBUS DP master; CANopen; Modbus (TCP, UDP); ETHERNET; Modbus® RTU; RS-232 serial interface; RS-485 interface; MQTT		PROFIBUS DP master; CANopen; Modbus (TCP, UDP); ETHERNET; Modbus® RTU; RS-232 serial interface; RS-485 interface; MQTT; Telecontrol protocols
ETHERNET protocols	DHCP; DNS; NTP; FTP; FTPS; SNMP; HTTP; HTTPS; SSH		
Telecontrol protocols	-		IEC 60870-5-101/-103/-104; IEC 61400-25; IEC 61850-7; DNP3

Visualization	Web-Visu		
Programming environment	WAGO-I/O-PRO V2.3 (based on CODESYS V2.3)		
CPU	Cortex A8; 600 MHz		
Operating system	Real-time Linux (with RT-Preempt patch)		
Main memory (RAM)/internal memory (flash)/non-volatile memory (hardware)	256 MB / 256 MB / 128 KB		
Program memory/data memory/non-volatile memory (software)	CODESYS V2: 16 MB / 64 MB / 128 KB		
Number of modules per node (max.)	250		
Input and output process image (internal) max.	1000 words/1000 words		
Input and output process image (Modbus®) max.	CODESYS V2: 1000 words/1000 words		
Input and output process image (PROFIBUS) max.	5000 bytes/5000 bytes		
Input and output process image (CAN) max.	2000 words/2000 words		
Supply voltage (system)	24 VDC (-25 ... +30 %); via pluggable connector (CAGE CLAMP® connection)		
Supply voltage (field)	24 VDC (-25 ... +30 %); via power jumper contacts		
Input current (typ.) at nominal load (24 V)	670 mA		
Total current (system supply)	1700 mA		
Ambient temperature (operation)	0 ... +55 °C	-20 ... +60 °C	
Dimensions W x H x D	(112 x 100 x 71.9) mm		
Approvals	CE; Marine; OrdLoc/HazLoc; ATEX/IECEx		
For data sheet and additional information, see:	wago.com/750-8208		

Accessories	Item no.	Item no.	Item no.
Memory Card SD; SLC-NAND; 2 GByte; Temperature from -40 to 90 °C	758-879/000-001	758-879/000-001	758-879/000-001
Memory Card SD; pSLC-NAND; 8 GB; Temperature range: -40 to 90 °C	758-879/000-2108	758-879/000-2108	758-879/000-2108



Controllers PFC200 XTR

Controllers PFC100/PFC200

- Maximum performance in a minimum space
- Also programmable in high-level languages based on Linux®
- Security packages with SSH and SSL/TLS
- Runtime system for CODESYS V3

◀ Section 6.1

Controllers PFC200 XTR

- The advantages of WAGO's PFC Controllers combined with the capabilities for extreme environments:
- High processing speed
- Multiple interfaces
- eXTRemely robust and maintenance-free

Section 6.5 ▶▶▶

Basic Controllers 100

- Freely programmable per IEC 61131-3 with CODESYS V3
- HTML-5-based Web visualization
- Syslog in compliance with RFC 5424 and role-based user management (RBAC)
- Large amount of memory for projects and data

Section 6.3 ▶

Controllers 750

- Controllers for all common fieldbus systems
- Programmable per IEC 61131-3
- Readily combines with the modules of the WAGO I/O System 750

Section 6.4 ▶▶

Controllers 750 XTR

- For demanding applications in which the following are critical:
- Extreme temperature resistance
- Immunity to electromagnetic interference and impulse voltages
- Vibration and shock resistance

Starter Kits

For the entry into the most diverse application possibilities

IoT Boxes







Integrating machines and plants into the Internet of Things

Section 6.6 ▶▶▶▶

Controllers PFC200 XTR

Contents

	Page
General Product Information	132
Variants	133
Interfaces and Types	133
Item Number Key	133
Installation Instructions	134
Standards and Rated Conditions for Railway Applications (EN 50155)	134
Standards and Rated Conditions	135
Approvals	135

CPU	Modbus (TCP, UDP)	EtherNet/IP™	EtherCAT	PROFIBUS	CANopen	BACnet/IP	OPC UA	Modbus RTU	Telecontrol Protocols	IoT Protocols	Description	Item No.	
	M/S	M/S	M			x*	x	x	x*	x			
 Cortex A8; 1 GHz	M/S	M/S	M			x*	x	x	x*	x	Controller PFC200; 2nd Generation; 4 x ETHERNET; Extreme	750-8210/040-000	136
 Cortex A8; 1 GHz	M/S	M/S	M			x*	x	x	x*	x	Controller PFC200; 2nd Generation; 2 x ETHERNET, 2 x 100Base-FX; Extreme	750-8211/040-000	137
 Cortex A8; 1 GHz	M/S	M/S	M			x*	x	x	x*	x	Controller PFC200; 2nd Generation; 2 x ETHERNET, RS-232/-485; Extreme	750-8212/040-000	138
	M/S	M/S	M			x*	x	x	x	x	Controller PFC200; 2nd Generation; 2 x ETHERNET, RS-232/-485; Telecontrol Technology; Extreme	750-8212/040-001	138
 Cortex A8; 1 GHz	M/S	M/S	M			x*	x	x	x*	x	Controller PFC200; 2nd Generation; 2 x ETHERNET M12, RS-232/-485; Extreme	750-8212/040-010	139
 Cortex A8; 1 GHz	M/S	M/S	M		M/S	x*	x		x*	x	Controller PFC200; 2nd Generation; 2 x ETHERNET M12, CAN, CANopen; Extreme	750-8213/040-010	140
 Cortex A8; 1 GHz	M/S	M/S	M	S	M/S	x*	x	x	x*	x	Controller PFC200; 2nd Generation; 2 x ETHERNET, RS-232/-485, CAN, CANopen, PROFIBUS Slave; Extreme	750-8216/040-000	141

M: Master, S: Slave; *requires an additional license

Controller PFC200 XTR

General Product Information

PFC200 XTR:

Taking It to the eXTReme – the Standard for 750 XTR

With the dark gray XTR version of the PFC200 Controller, you will benefit from the unique added value of this fast and highly communicative multi-talented controller for applications that are subjected to extreme environments.

The PFC200 XTR Controller excels with high processing speed and multiple interfaces for parallel communication. All variants of this controller feature two ETHERNET ports and – depending on the model – additional interfaces. The CANopen, PROFIBUS DP and Modbus TCP/UDP/RTU protocols allow flexible connection to fieldbus systems and external input/output devices. These fieldbus systems can be easily configured directly in the development environment. The ETHERNET interfaces with an integrated switch also support all major IT protocols. In addition to multiple interfaces, the PFC200 XTR offers ample memory for your applications provided by the internal flash memory and an integrated interface for SD/SDHC cards.

Extremely temperature-resistant, immune to interference, as well as unfazed by vibrations and impulse voltages – the WAGO I/O System 750 XTR is the first choice for demanding applications including:

- Marine systems and onshore/offshore installations
- Renewable energy systems (wind turbines, solar systems and biogas plants)
- Transformer stations and power distribution systems
- Petrochemical processing
- Water and wastewater treatment systems
- Custom machines
- Railway systems

Industry 4.0 / IoT

Recording, digitizing and linking data profitably – these are the core ideas of Industry 4.0. Using a dedicated library, WAGO's PFC100/ PFC200 Controllers become IoT controllers that send data from the field level to the cloud. Once in the cloud, data can be aggregated and used for analysis. This capability creates tremendous added value for your company – whether it's increasing the efficiency of in-house production, implementing energy management in buildings or developing additional end-customer services. Existing systems also become IoT-ready, making them future-proof. The WAGO PFC family of controllers thus forms the basis for a sustainable corporate world.

Link between Process Data and IT Application – Even under eXTReme Conditions

The PFC200 XTR ideally combines real-time requirements with IT functionality. It supports both Modbus/TCP and EtherNet/IP for use in industrial environments. HTTP, SNMP, FTP, BootP, DHCP, DNS and other protocols simplify integration into IT environments. Integrated Web pages and Web-based visualization provide IT applications with real-time process data. Furthermore, the controller incorporates library functions for email, SOAP, ASP, IP configuration, ETHERNET sockets and file system.

Security on Board

The topics of ETHERNET communication and security are closely linked. To provide PFC Controller users with a high level of security, mechanisms for secure connections such as HTTPS, FTPS, SSH and SSL/TLS are standard.

Worldwide Approvals

International approvals for industrial automation, building technology, shipbuilding and onshore/offshore applications guarantee worldwide use – even under harsh operating conditions, e.g., Germanischer Lloyd, Det Norske Veritas, American Bureau of Shipping, Korean Register of Shipping, Nippon Kaiji Kyokai, Registro Italiano Navale and Polski Rejestr Stratkow.

Superior Reliability in Extreme Climates

Engineered for freezing cold, extreme heat and high humidity, the WAGO I/O System 750 XTR provides absolute dependability in virtually any weather. The XTR version of the PFC200 is unfazed by both freezing cold down to -40°C and scorching heat up to +70°C. And this applies equally for both start-up and ongoing operation. The maximum approved operating altitude of 5,000 m is another highlight. Even in the thin air of a mountain-top station, the system impressively demonstrates its high performance and availability.

Additional Protection against Interference Pulses

The WAGO I/O System 750 XTR provides greater isolation up to 5 kV of impulse voltage, lower EMC emission of interference and higher insensitivity to EMC interference. These strengths ensure trouble-free operation.

High Mechanical Performance

Automation systems must be incredibly vibration-resistant, especially when installed close to vibration-prone and shock-generating system components. Powerful motors and power circuit breakers are just two examples of the many applications that can stress automation systems. The WAGO I/O System 750 XTR continues to set new standards here. Count on long-lasting, trouble-free operation and industry-topping levels of safety – even in the most severe applications, such as tunnel boring machines.

Modular and Expandable

With the WAGO I/O System 750 XTR, the PFC200 Controllers can be expanded to almost any input/output interface. Using an industry-leading platform, the 750 XTR boasts the same proven benefits.

Open-Source Software and Linux®

We unite what belongs together: High-performance WAGO Hardware and future-ready Linux® Operating System. For complex tasks, you can choose between programming in IEC 61131 or directly under Linux®. WAGO's "Embedded Linux" Controllers impress with base images that are expandable via open-source packages. As a "Gold Member" of the Open Source Automation Development Lab (OSADL), WAGO supports both financing and further development of Linux® in the industrial sector. The controller firmware itself is available as a "Board Support Package" (BSP). If you are interested, simply contact our AUTOMATION technical support.



Benefits:

- Controllers for eXTReme environmental conditions
 - No air conditioning required
 - Can be used in unshielded areas
 - Install close to vibrating and shock-generating system components
- Programming per IEC 61131-3
- Can be combined with high-level languages
- Linux® real-time operating system
- Rugged and maintenance-free
- Integrated IT security standards
- IoT ready

Controller PFC200 XTR Variants

Telecontrol Technology

The PFC200 models for telecontrol technology integrate the following standardized telecontrol protocols:

- IEC 60870-5
- IEC 61850
- IEC 61400-25
- DNP3

These controllers also meet stricter requirements for immunity to impulse voltages and electromagnetic interference according to EN 60870-2-1.



Interfaces and Types

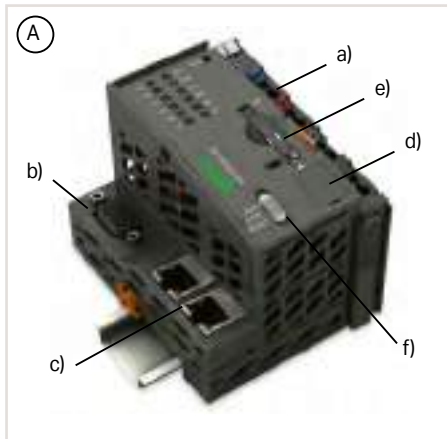

- Includes a supply module (a) to power downstream I/O modules
- Technical differences on the connection level (b)
- ETHERNET 2 x RJ-45 (c)
- Service interface (d)
- SD card slot for external storage media (e)
- Start/stop switch (f)

Housing Design (A)

- W x H x D (mm): 78.6 x 100 x 71.9

Housing Design (B)

- W x H x D (mm): 112 x 100 x 71.9

Housing Design (C)

- ETHERNET 2 x M12 connector (g)
- W x H x D (mm): 112 x 100 x 71.9

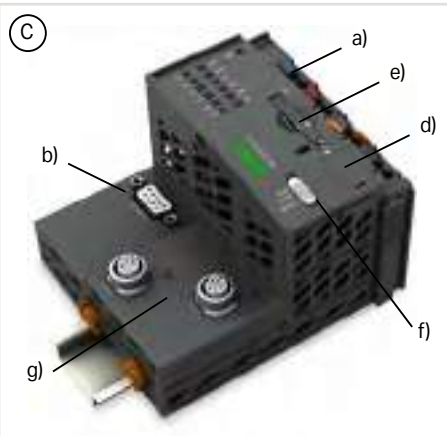
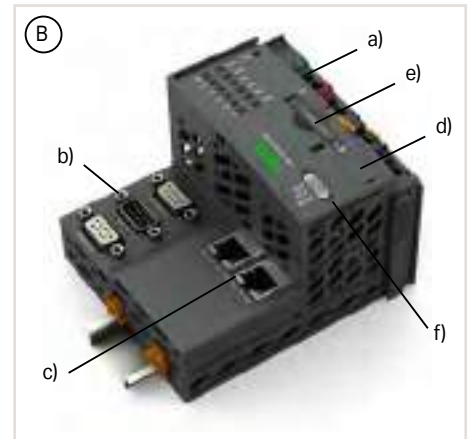

Item Number Key

Explanation of an item number key's components

Item No. : 750-82xy/040-000	
0y:	Generation 1
1y:	Generation 2
x0:	4 x ETHERNET
x1:	2 x ETHERNET, 2 x SFP port
x2:	2 x ETHERNET, RS-232/-485
x3:	2 x ETHERNET, CAN
x6:	2 x ETHERNET, RS-232/-485, CAN, CANopen
.../040-000: Standard	
.../040-001: Telecontrol technology	
.../040-010: M12 connector	

Controller PFC200 XTR Installation Instructions

Power Supply

The internal electronics are powered by the controller. The power supply to the field-side supply is electrically isolated. This division enables a separate supply for sensors and actuators. Snapping the I/O modules together automatically routes the supply voltages. Supply modules with diagnostics also enable power supply monitoring. This ensures a flexible and customized supply configuration for a fieldbus node. Power supply to the electronics is limited by a maximum value. If the sum of the internal current demand of all the I/O modules should exceed this value, an additional system supply module is necessary. Furthermore, the current consumed for field-side supply must not exceed 10 A. A variety of power supply modules allows re-feeding, creating potential groups and implementing emergency stops.

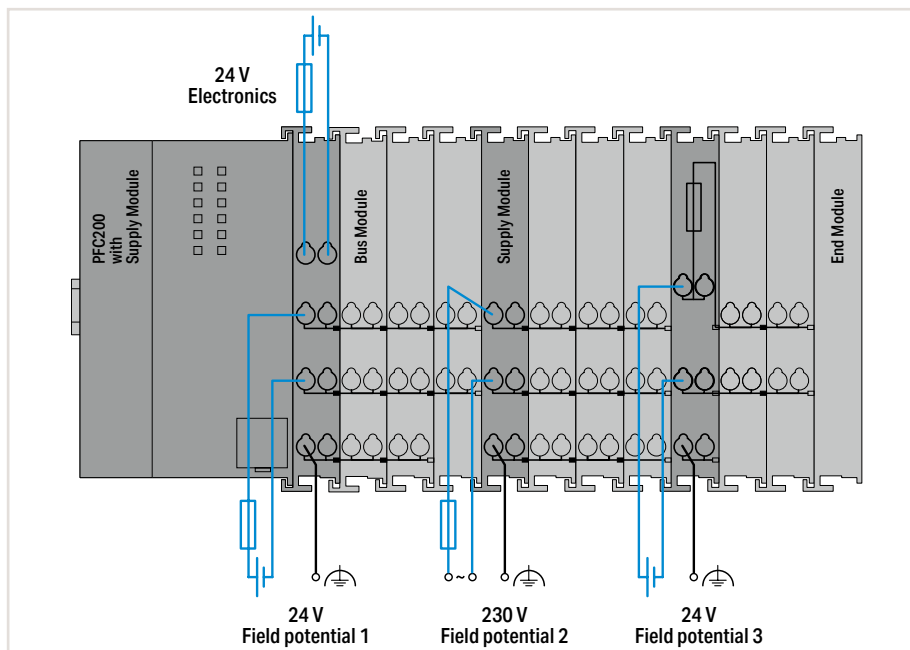

Notes

Additional steps must be implemented based on where the I/O system is installed:

Specific power and field-side power supply filters (750-624/040-001 or 750-626/040-000) are ready for marine and onshore/offshore applications, as well as in telecontrol and rail technology.

Please refer to the manual for details about the power supply's design.

Mixed Operation

Mixed operation (standard/XTR modules) within a node is possible when groups of modules are electrically isolated on the field side (i.e., electrically isolated power supply). This combination may be useful, for example, when there are only increased requirements for immunity to impulse voltages and interference, but the surrounding air temperature is not critical.

Standards and Rated Conditions for Rail Applications (EN 50155)

Railway Applications (EN 50155)	Class/Standard Compliance
4.1 Rated operating conditions	
4.1.1 Altitude above sea level	AX (EN 50125-1)
4.1.2 Surrounding air temperature	TX
4.1.3 Shock and vibration	1A and 1B (EN 61373)
4.1.4 Relative humidity	95 % (coated PCBs)
5.1 Power supply	
5.1.1.1 Voltage fluctuations	
Minimum voltage	0.725 x Un
Maximum voltage	1.3 x Un
5.1.1.2 Power interruptions	S1
5.4 Surge, ESD, burst tests	EN 50121-3-2
5.5 EMC (emission of interference, immunity to interference)	EN 50121-3-2, EN 50121-4, -5
Fire behavior: per EN 45545-2 hazard level HL3	

WAGO is certified in accordance with the IRIS quality standard.

Controller PFC200 XTR

Standards and Rated Conditions

General technical data	
Supply voltage (system)	24 VDC; via pluggable connector (CAGE CLAMP® connection); Derating must be observed!
Ambient temperature (operation)	-40 ... +70 °C
Surrounding air temperature (storage)	-40 ... +85 °C
Relative humidity (without condensation)	95 %
Relative humidity (with condensation)	Short-term condensation per Class 3K7/IEC EN 60721-3-3 and E-DIN 40046-721-3 (except for wind-driven precipitation, water and ice formation)
Operating altitude	without temperature derating: 0 ... 2000 m; with temperature derating: 2000 ... 5000 m (0.5 K/100 m); 5000 m (max.)
Pollution degree	2 per IEC 61131-2
Vibration resistance	per IEC 60068-2-6 (acceleration: 5g), EN 60870-2-2, IEC 60721-3-1, -3, EN 50155; EN 61373
Shock resistance	per IEC 60068-2-27 (15g/11 ms/half-sine/1,000 shocks; 25g/6 ms/1,000 shocks), EN 50155, EN 61373
EMC immunity to interference	per EN 61000-6-1, -2; EN 61131-2; marine applications; EN 50121-3-2; EN 50121-4, -5; EN 60255-26; EN 60870-2-1; EN 61850-3; IEC 61000-6-5; IEEE 1613; VDEW: 1994
EMC emission of interference	per EN 61000-6-3, -4, EN 61131-2, EN 60255-26, marine applications, EN 60870-2-1, EN 61850-3, EN 50121-3-2, EN 50121-4, -5
Protection type	IP20
Mounting position	horizontal (standing/lying); vertical
Mounting type	DIN-35 rail
Housing material	Polycarbonate; polyamide 6.6
Exposure to pollutants	per IEC 60068-2-42 and IEC 60068-2-43
Connection technology: system supply	2 x CAGE CLAMP®
Connection technology: field supply	4 x CAGE CLAMP®
Solid conductor	0.25 ... 2.5 mm ² / 24 ... 14 AWG
Fine-stranded conductor	0.25 ... 2.5 mm ² / 24 ... 14 AWG
Strip length	8 ... 9 mm / 0.31 ... 0.35 inches
Current carrying capacity (power jumper contacts)	10 A

Approvals

For approvals overview (item comparison), see Section 14 (Technical Section) or visit www.wago.com.



Cables and connectors	Page 680
Communication	Page 678
DIN-rail	Page 716
Marking	Page 714
Shield termination	Page 708
Software	Page 12
System enclosure	Page 693

Controller PFC200 XTR ▶ 4 x ETHERNET



750-8210/040-000

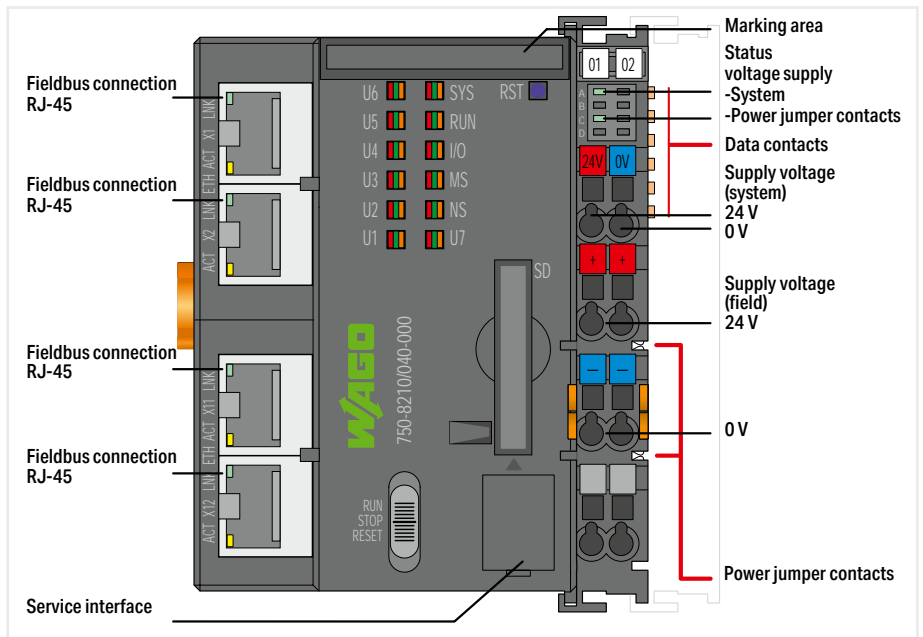

Version
Item no.
Order Text

extreme
750-8210/040-000
PFC200; G2; 4ETH; XTR

Technical data
Communication

Modbus TCP master/slave; Modbus (UDP); Modbus (RTU); ETHERNET; EtherNet/IP™ Adapter (slave); EtherNet/IP™ Scanner; EtherCAT® Master; OPC UA Server/Client; OPC UA Pub/Sub (can be installed later); MQTT; BACnet/IP, **requires an additional license**; Telecontrol protocols, **requires an additional license**

ETHERNET protocols
Telecontrol protocols

DHCP; DNS; NTP; FTP; FTPS; SNMP; HTTP; HTTPS; SSH
IEC 60870 (additional license as slave or master); IEC 61850 (additional license as Client or Server); DNP3 (additional license as Slave or Master)

Visualization
Programming environment

Web-Visu
CODESYS V3.5, from firmware release 23; **e!COCKPIT** (based on CODESYS V3), up to firmware release 22; WAGO-I/O-PRO V2.3 (based on CODESYS V2.3), up to firmware release 22

CPU
Operating system

Cortex A8; 1 GHz
Real-time Linux (with RT-Preempt patch)

Main memory (RAM)/internal memory (flash)/non-volatile memory (hardware)
--

512 MB / 4 GB / 128 KB

Program memory/data memory/non-volatile memory (software)

CODESYS V2: 16 MB / 64 MB / 128 KB; CODESYS V3: 32 MB / 128 MB / 128 KB

Number of modules per node (max.)
Input and output process image (internal) max.

64
1000 words/1000 words

Input and output process image (Modbus®) max.

CODESYS V2: 1000 words/1000 words; CODESYS V3: 32000 words/32000 words

Supply voltage (system)
Supply voltage (field)

24 VDC; via pluggable connector (CAGE CLAMP® connection); Derating must be observed!
24 VDC; Power supply via pluggable connector (CAGE CLAMP® connection); Transmission via power jumper contacts; Derating must be observed!

Derating

Derating (supply voltage): Surrounding air temperatures under laboratory conditions: (-25 ... +30 %); for -40 ... +55 °C: 24 V (-25 ... +20 %); for +55 ... +70 °C: 24 V (-25 ... +10 %); Lower limit in all temperature ranges: -27.5 % (including 15 % residual ripple)

Input current (typ.) at nominal load (24 V)
Total current (system supply)

500 mA
1700 mA

Ambient temperature (operation)
Dimensions W x H x D

-40 ... +70 °C
(78.6 x 100 x 71.9) mm

Approvals
For data sheet and additional information, see:

CE, OrdLoc
wago.com/750-8210/040-000

Product Expansions
Runtime; BACnet; 300; Single License
Runtime; DNP3 Master; M; Single License
Runtime; IEC60870 Slave; Single License
Runtime; DNP3 Slave; Single License
Runtime; IEC60870 Master; M; Single License
Runtime; IEC61850 Client; M; Single License
Runtime; IEC61850 Server; Single License

Item no.
2759-283/211-1000
2759-2293/211-1000
2759-290/211-1000
2759-2290/211-1000
2759-293/211-1000
2759-2243/211-1000
2759-2240/211-1000

Accessories
Memory Card SD; SLC-NAND; 2 GByte; Temperature from -40 to 90 °C
Memory Card SD; pSLC-NAND; 8 GB; Temperature range: -40 to 90 °C

Item no.
758-879/000-001
758-879/000-2108

6.2

Controller PFC200 XTR ▶ 2 x ETHERNET, 2 x SFP port



750-8211/040-000

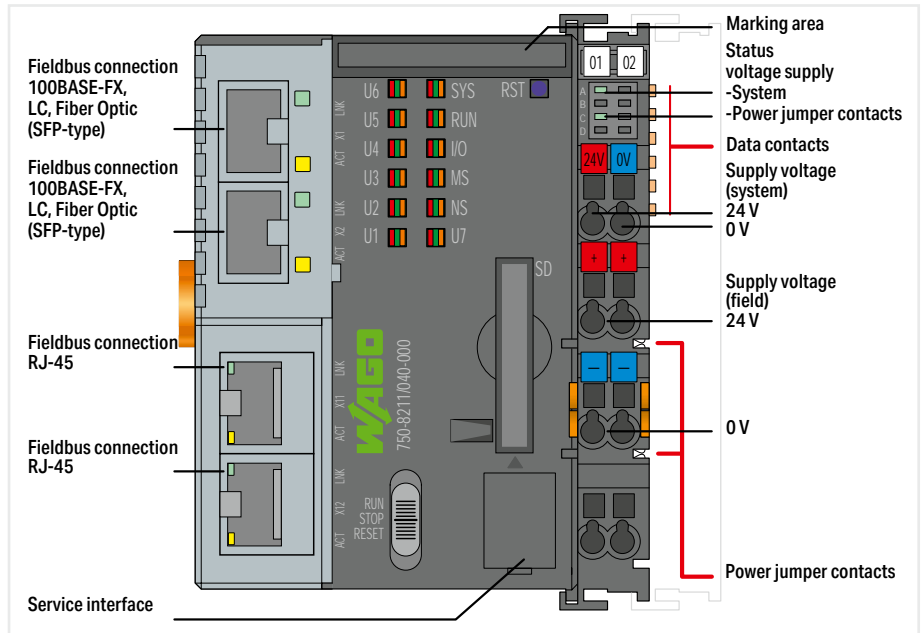

Version	extreme
Item no.	750-8211/040-000
Order Text	PFC200; G2; 2ETH, 2SFP; XTR

Version	extreme
Item no.	750-8211/040-000
Order Text	PFC200; G2; 2ETH, 2SFP; XTR

Technical data	
Communication	

Communication	Modbus TCP master/slave; Modbus (UDP); Modbus (RTU); ETHERNET; EtherNet/IP™ Adapter (slave); EtherNet/IP™ Scanner; EtherCAT® Master; OPC UA Server/Client; OPC UA Pub/Sub (can be installed later); MQTT; BACnet/IP, requires an additional license ; Telecontrol protocols, requires an additional license
ETHERNET protocols	DHCP; DNS; NTP; FTP; FTPS; SNMP; HTTP; HTTPS; SSH
Telecontrol protocols	IEC 60870 (additional license as slave or master); IEC 61850 (additional license as Client or Server); DNP3 (additional license as Slave or Master)

ETHERNET protocols	
Telecontrol protocols	

Visualization	Web-Visu
Programming environment	CODESYS V3.5, from firmware release 23; e!COCKPIT (based on CODESYS V3), up to firmware release 22; WAGO-I/O-PRO V2.3 (based on CODESYS V2.3), up to firmware release 22

Visualization	
Programming environment	

CPU	Cortex A8; 1 GHz
Operating system	Real-time Linux (with RT-Preempt patch)

CPU	
Operating system	

Main memory (RAM)/internal memory (flash)/non-volatile memory (hardware)	512 MB / 4 GB / 128 KB
--	------------------------

Main memory (RAM)/internal memory (flash)/non-volatile memory (hardware)	
--	--

Program memory/data memory/non-volatile memory (software)	CODESYS V2: 16 MB / 64 MB / 128 KB; CODESYS V3: 32 MB / 128 MB / 128 KB
---	---

Program memory/data memory/non-volatile memory (software)	
---	--

Number of modules per node (max.)	64
-----------------------------------	----

Number of modules per node (max.)	
-----------------------------------	--

Input and output process image (internal) max.	1000 words/1000 words
--	-----------------------

Input and output process image (internal) max.	
--	--

Input and output process image (Modbus®) max.	CODESYS V2: 1000 words/1000 words; CODESYS V3: 32000 words/32000 words
---	--

Input and output process image (Modbus®) max.	
---	--

Supply voltage (system)	24 VDC; via pluggable connector (CAGE CLAMP® connection); Derating must be observed!
-------------------------	--

Supply voltage (system)	
-------------------------	--

Supply voltage (field)	24 VDC; Power supply via pluggable connector (CAGE CLAMP® connection); Transmission via power jumper contacts; Derating must be observed!
------------------------	---

Supply voltage (field)	
------------------------	--

Derating	Derating (supply voltage): Ambient temperatures under laboratory conditions: (-25 ... +30 %); for -40 ... +55 °C: 24 V (-25 ... +20 %); for +55 ... +70 °C: 24 V (-25 ... +10 %); Lower limit in all temperature ranges: -27.5 % (including 15 % residual ripple)
----------	---

Derating	
----------	--

Input current (typ.) at nominal load (24 V)	550 mA
---	--------

Input current (typ.) at nominal load (24 V)	
---	--

Total current (system supply)	1700 mA
-------------------------------	---------

Total current (system supply)	
-------------------------------	--

Ambient temperature (operation)	-40 ... +70 °C
---------------------------------	----------------

Ambient temperature (operation)	
---------------------------------	--

Dimensions W x H x D	(78.6 x 100 x 71.9) mm
----------------------	------------------------

Dimensions W x H x D	
----------------------	--

Approvals	CE; Marine; OrdLoc
-----------	--------------------

Approvals	
-----------	--

For data sheet and additional information, see:	wago.com/750-8211/040-000
---	---------------------------

For data sheet and additional information, see:	
---	--

Product Expansions

Runtime; BACnet; 300; Single License	
Runtime; DNP3 Master; M; Single License	
Runtime; IEC60870 Slave; Single License	
Runtime; DNP3 Slave; Single License	
Runtime; IEC60870 Master; M; Single License	
Runtime; IEC61850 Client; M; Single License	
Runtime; IEC61850 Server; Single License	

Item no.	750-8211/040-000
	2759-283/211-1000
	2759-2293/211-1000
	2759-290/211-1000
	2759-2290/211-1000
	2759-293/211-1000
	2759-2243/211-1000
	2759-2240/211-1000

Accessories

Memory Card SD; SLC-NAND; 2 GByte; Temperature from -40 to 90 °C	
SFP Module 100BASE; FX Multi-Mode 1310 nm LC; 2 km; DDM; Extreme; silver-colored	
Memory Card SD; pSLC-NAND; 8 GB; Temperature range: -40 to 90°C	

Item no.	758-879/000-001
	852-202
	758-879/000-2108

Controller PFC200 XTR ▶ 2 x ETHERNET, RS-232/-485



750-8212/040-000

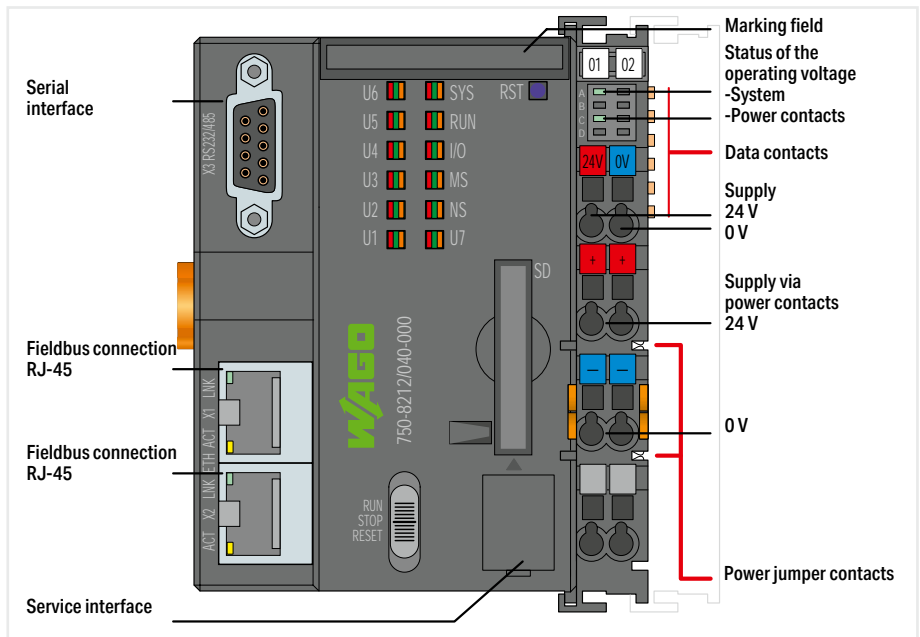

Version	extreme	Telecontrol technology; extreme
Item no.	750-8212/040-000	750-8212/040-001
Order Text	PFC200; G2; 2ETH RS; XTR	PFC200; G2; 2ETH RS; Tele; XTR

Technical data		
Communication	Modbus TCP master/slave; Modbus (UDP); Modbus (RTU); ETHERNET; EtherNet/IP™ Adapter (slave); EtherNet/IP™ Scanner; EtherCAT® Master; OPC UA Server/Client; OPC UA Pub/Sub (can be installed later); MQTT; RS-232 serial interface; RS-485 interface; BACnet/IP, requires an additional license ; Telecontrol protocols, requires an additional license	Modbus TCP master/slave; Modbus (UDP); Modbus (RTU); ETHERNET; EtherNet/IP™ Adapter (slave); EtherNet/IP™ Scanner; EtherCAT® Master; OPC UA Server/Client; OPC UA Pub/Sub (can be installed later); MQTT; Telecontrol protocols; RS-232 serial interface; RS-485 interface; BACnet/IP, requires an additional license
ETHERNET protocols	DHCP; DNS; NTP; FTP; FTPS; SNMP; HTTP; HTTPS; SSH	
Telecontrol protocols	IEC 60870 (additional license as slave or master); IEC 61850 (additional license as Client or Server); DNP3 (additional license as Slave or Master)	IEC 60870; IEC 61850; DNP3
Visualization	Web-Visu	
Programming environment	CODESYS V3.5, from firmware release 23; e!COCKPIT (based on CODESYS V3), up to firmware release 22; WAGO-I/O-PRO V2.3 (based on CODESYS V2.3), up to firmware release 22	
CPU	Cortex A8; 1 GHz	
Operating system	Real-time Linux (with RT-Preempt patch)	
Main memory (RAM)/internal memory (flash)/non-volatile memory (hardware)	512 MB / 4 GB / 128 KB	
Program memory/data memory/non-volatile memory (software)	CODESYS V2: 16 MB / 64 MB / 128 KB; CODESYS V3: 32 MB / 128 MB / 128 KB	
Number of modules per node (max.)	64	
Input and output process image (internal) max.	1000 words/1000 words	
Input and output process image (Modbus®) max.	CODESYS V2: 1000 words/1000 words; CODESYS V3: 32000 words/32000 words	
Supply voltage (system)	24 VDC; via pluggable connector (CAGE CLAMP® connection); Derating must be observed!	
Supply voltage (field)	24 VDC; Power supply via pluggable connector (CAGE CLAMP® connection); Transmission via power jumper contacts; Derating must be observed!	
Derating	Derating (supply voltage): Ambient temperatures under laboratory conditions: (-25 ... +30 %); for -40 ... +55 °C: 24 V (-25 ... +20 %); for +55 ... +70 °C: 24 V (-25 ... +10 %); Lower limit in all temperature ranges: -27.5 % (including 15 % residual ripple)	
Input current (typ.) at nominal load (24 V)	550 mA	
Total current (system supply)	1700 mA	
Ambient temperature (operation)	-40 ... +70 °C	
Dimensions W x H x D	(78.6 x 100 x 71.9) mm	
Approvals	CE; Marine; OrdLoc/HazLoc	
For data sheet and additional information, see:	wago.com/750-8212/040-000	

Product Expansions	Item no.	Item no.
Runtime; BACnet; 300; Single License	2759-283/211-1000	2759-283/211-1000
Runtime; DNP3 Master; M; Single License	2759-2293/211-1000	-
Runtime; IEC60870 Slave; Single License	2759-290/211-1000	-
Runtime; DNP3 Slave; Single License	2759-2290/211-1000	-
Runtime; IEC60870 Master; M; Single License	2759-293/211-1000	-
Runtime; IEC61850 Client; M; Single License	2759-2243/211-1000	-
Runtime; IEC61850 Server; Single License	2759-2240/211-1000	-
Accessories	Item no.	Item no.
Memory Card SD; SLC-NAND; 2 GB	758-879/000-001	758-879/000-001
Memory Card SD; pSLC-NAND; 8 GB	758-879/000-2108	758-879/000-2108

6.2

Controller PFC200 XTR ▶ 2 x ETHERNET M12, RS-232/-485



750-8212/040-010

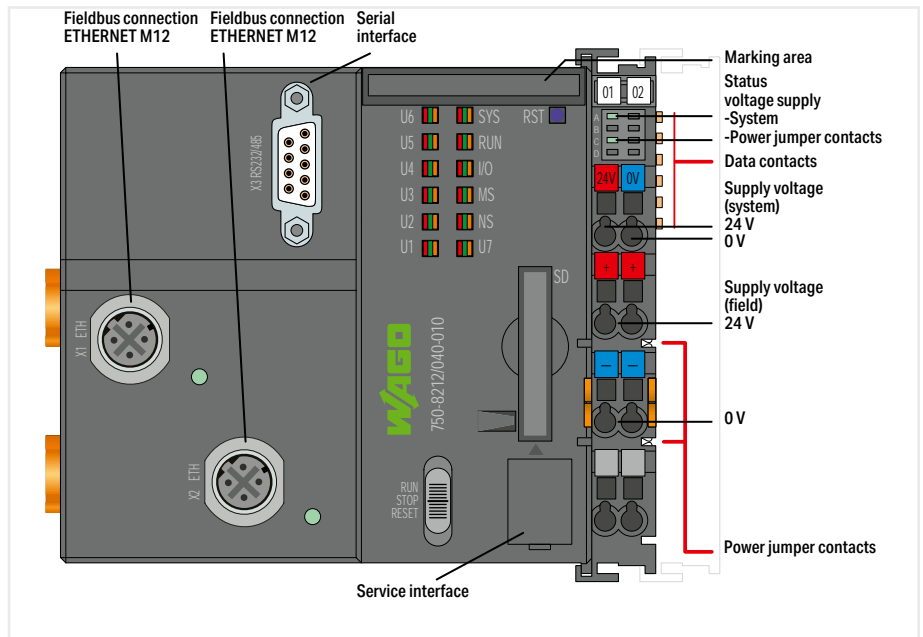

Version	M12; extreme
Item no.	750-8212/040-010
Order Text	PFC200 G2 2ETH M12 RS; XTR

Version	M12; extreme
Item no.	750-8212/040-010
Order Text	PFC200 G2 2ETH M12 RS; XTR

Technical data	
Communication	

Modbus TCP master/slave; Modbus (UDP); Modbus (RTU); ETHERNET; EtherNet/IP™ Adapter (slave); EtherNet/IP™ Scanner; EtherCAT® Master; OPC UA Server/Client; OPC UA Pub/Sub (can be installed later); MQTT; RS-232 serial interface; RS-485 interface; BACnet/IP; **requires an additional license**; Telecontrol protocols, **requires an additional license**

ETHERNET protocols	DHCP; DNS; NTP; FTP; FTPS; SNMP; HTTP; HTTPS; SSH
Telecontrol protocols	IEC 60870 (additional license as slave or master); IEC 61850 (additional license as Client or Server); DNP3 (additional license as Slave or Master)

Web-Visu
CODESYS V3.5, from firmware release 23; **e!COCKPIT** (based on CODESYS V3), up to firmware release 22; WAGO-I/O-PRO V2.3 (based on CODESYS V2.3), up to firmware release 22

Visualization	
Programming environment	

Cortex A8; 1 GHz
Real-time Linux (with RT-Preempt patch)
512 MB / 4 GB / 128 KB

CPU	
Operating system	
Main memory (RAM)/internal memory (flash)/non-volatile memory (hardware)	
Program memory/data memory/non-volatile memory (software)	

CODESYS V2: 16 MB / 64 MB / 128 KB; CODESYS V3: 32 MB / 128 MB / 128 KB

Number of modules per node (max.)	64
Input and output process image (internal) max.	1000 words/1000 words

CODESYS V2: 1000 words/1000 words; CODESYS V3: 32000 words/32000 words

Input and output process image (Modbus®) max.	
Supply voltage (system)	24 VDC; via pluggable connector (CAGE CLAMP® connection); Derating must be observed!
Supply voltage (field)	24 VDC; Power supply via pluggable connector (CAGE CLAMP® connection); Transmission via power jumper contacts; Derating must be observed!

Derating (supply voltage): Ambient temperatures under laboratory conditions: (-25 ... +30 %); for -40 ... +55 °C: 24 V (-25 ... +20 %); for +55 ... +70 °C: 24 V (-25 ... +10 %); Lower limit in all temperature ranges: -27.5 % (including 15 % residual ripple)

Derating	
Input current (typ.) at nominal load (24 V)	550 mA
Total current (system supply)	1700 mA
Ambient temperature (operation)	-40 ... +70 °C
Dimensions W x H x D	(112 x 100 x 71.9) mm

CE; Marine; OrdLoc/HazLoc; ATEX/IECEx
wago.com/750-8212/040-010

Approvals	
For data sheet and additional information, see:	

Product Expansions	
Runtime; BACnet; 300; Single License	
Runtime; DNP3 Master; M; Single License	
Runtime; IEC60870 Slave; Single License	
Runtime; DNP3 Slave; Single License	
Runtime; IEC60870 Master; M; Single License	
Runtime; IEC61850 Client; M; Single License	
Runtime; IEC61850 Server; Single License	

Item no.	
	2759-283/211-1000
	2759-2293/211-1000
	2759-290/211-1000
	2759-2290/211-1000
	2759-293/211-1000
	2759-2243/211-1000
	2759-2240/211-1000

Accessories	
Memory Card SD; SLC-NAND; 2 GByte; Temperature from -40 to 90 °C	
Memory Card SD; pSLC-NAND; 8 GB; Temperature range: -40 to 90 °C	

Item no.	
	758-879/000-001
	758-879/000-2108

Controller PFC200 XTR ▶ 2 x ETHERNET M12, CAN, CANOpen



750-8213/040-010

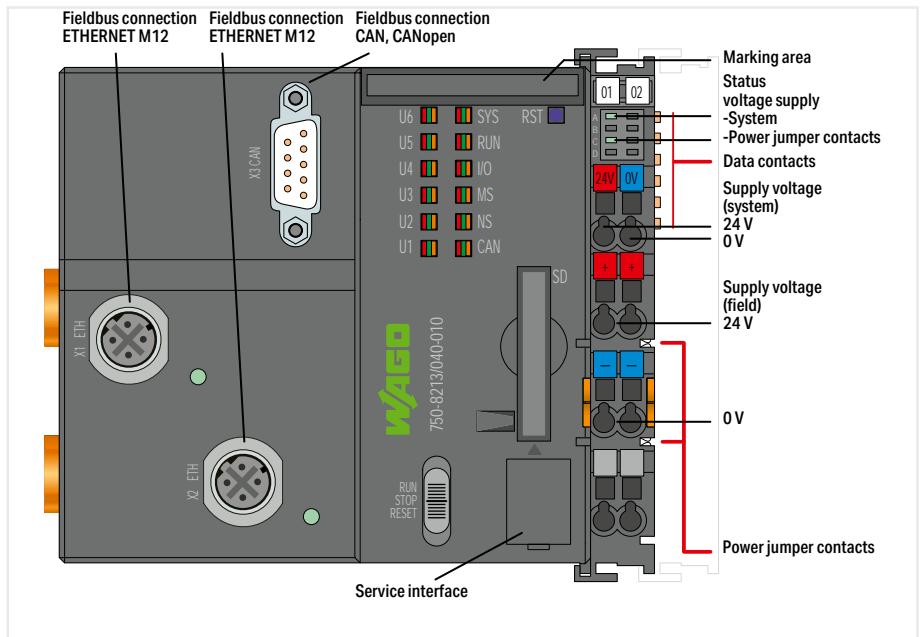

Version	M12; extreme
Item no.	750-8213/040-010
Order Text	PFC200 G2 2ETH M12 CAN; XTR

Technical data

Communication	CANopen; Modbus TCP master/slave; Modbus (UDP); ETHERNET; EtherNet/IP™ Adapter (slave); EtherNet/IP™ Scanner; EtherCAT® Master; OPC UA Server/Client; OPC UA Pub/Sub (can be installed later); MQTT; BACnet/IP, requires an additional license ; Telecontrol protocols, requires an additional license
---------------	--

ETHERNET protocols	DHCP; DNS; NTP; FTP; FTPS; SNMP; HTTP; HTTPS; SSH
--------------------	---

Telecontrol protocols	IEC 60870 (additional license as slave or master); IEC 61850 (additional license as Client or Server); DNP3 (additional license as Slave or Master)
-----------------------	---

Visualization

Programming environment	Web-Visu CODESYS V3.5, from firmware release 23; e!COCKPIT (based on CODESYS V3), up to firmware release 22; WAGO-I/O-PRO V2.3 (based on CODESYS V2.3), up to firmware release 22
-------------------------	---

CPU	Cortex A8; 1 GHz
-----	------------------

Operating system	Real-time Linux (with RT-Preempt patch)
------------------	---

Main memory (RAM)/internal memory (flash)/non-volatile memory (hardware)	512 MB / 4 GB / 128 KB
--	------------------------

Program memory/data memory/non-volatile memory (software)	CODESYS V2: 16 MB / 64 MB / 128 KB; CODESYS V3: 32 MB / 128 MB / 128 KB
---	---

Number of modules per node (max.)	64
-----------------------------------	----

Input and output process image (internal) max.	1000 words/1000 words
--	-----------------------

Input and output process image (Modbus®) max.	CODESYS V2: 1000 words/1000 words; CODESYS V3: 32000 words/32000 words
---	--

Input and output process image (CAN) max.	2000 words/2000 words
---	-----------------------

Supply voltage (system)	24 VDC; via pluggable connector (CAGE CLAMP® connection); Derating must be observed!
-------------------------	--

Supply voltage (field)	24 VDC; Power supply via pluggable connector (CAGE CLAMP® connection); Transmission via power jumper contacts; Derating must be observed!
------------------------	---

Derating

Derating (supply voltage): Ambient temperatures under laboratory conditions: (-25 ... +30 %); for -40 ... +55 °C: 24 V (-25 ... +20 %); for +55 ... +70 °C: 24 V (-25 ... +10 %); Lower limit in all temperature ranges: -27.5 % (including 15 % residual ripple)	
---	--

Input current (typ.) at nominal load (24 V)	550 mA
---	--------

Total current (system supply)	1700 mA
-------------------------------	---------

Ambient temperature (operation)	-40 ... +70 °C
---------------------------------	----------------

Dimensions W x H x D	(112 x 100 x 71.9) mm
----------------------	-----------------------

Approvals	CE; Marine; OrdLoc/HazLoc; ATEX/IECEX
-----------	---------------------------------------

For data sheet and additional information, see:	wago.com/750-8213/040-010
---	---------------------------

Product Expansions

Runtime; BACnet; 300; Single License	2759-283/211-1000
--------------------------------------	-------------------

Runtime; DNP3 Master; M; Single License	2759-2293/211-1000
---	--------------------

Runtime; IEC60870 Slave; Single License	2759-290/211-1000
---	-------------------

Runtime; DNP3 Slave; Single License	2759-2290/211-1000
-------------------------------------	--------------------

Runtime; IEC60870 Master; M; Single License	2759-293/211-1000
---	-------------------

Runtime; IEC61850 Client; M; Single License	2759-2243/211-1000
---	--------------------

Runtime; IEC61850 Server; Single License	2759-2240/211-1000
--	--------------------

Accessories

Memory Card SD; SLC-NAND; 2 GByte; Temperature from -40 to 90 °C	758-879/000-001
--	-----------------

Memory Card SD; pSLC-NAND; 8 GB; Temperature range: -40 to 90 °C	758-879/000-2108
--	------------------

6.2

Controller PFC200 XTR ▶ 2 x ETHERNET, RS-232/-485, CAN, CANopen, PROFIBUS slave



750-8216/040-000

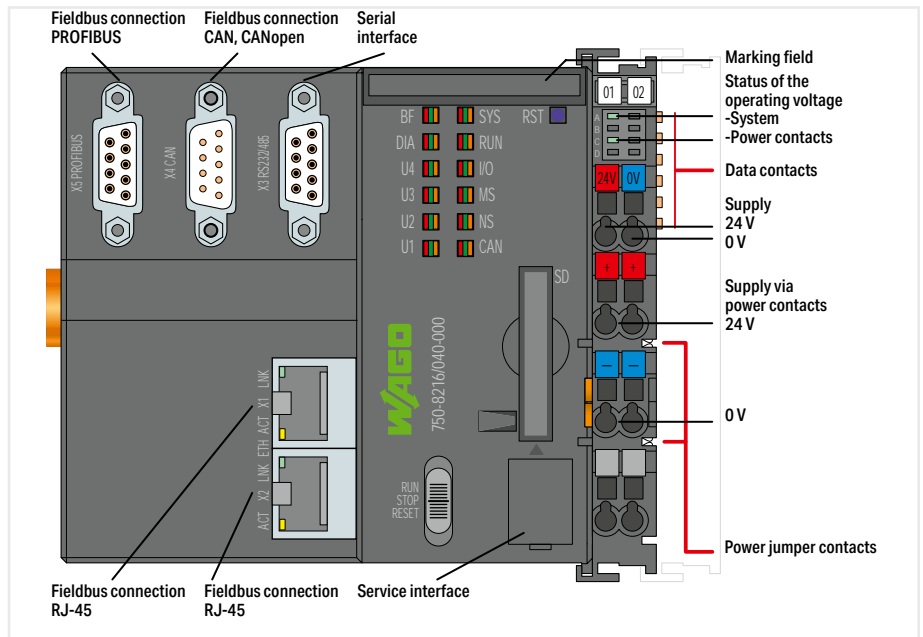

Version	extreme
Item no.	750-8216/040-000
Order Text	PFC200; G2; 2ETH RS CAN DPS; XTR

Technical data	
Communication	PROFIBUS; CANopen; Modbus TCP master/slave; Modbus (UDP); Modbus (RTU); ETHERNET; EtherNet/IP™ Adapter (slave); EtherNet/IP™ Scanner; EtherCAT® Master; OPC UA Server/Client; OPC UA Pub/Sub (can be installed later); MQTT; RS-232 serial interface; RS-485 interface; BACnet/IP, requires an additional license ; Telecontrol protocols, requires an additional license
ETHERNET protocols	DHCP; DNS; NTP; FTP; FTPS; SNMP; HTTP; HTTPS; SSH
Telecontrol protocols	IEC 60870 (additional license as slave or master); IEC 61850 (additional license as Client or Server); DNP3 (additional license as Slave or Master)
Visualization	Web-Visu
Programming environment	CODESYS V3.5, from firmware release 23; e!COCKPIT (based on CODESYS V3), up to firmware release 22; WAGO-I/O-PRO V2.3 (based on CODESYS V2.3), up to firmware release 22
CPU	Cortex A8; 1 GHz
Operating system	Real-time Linux (with RT-Preempt patch)
Main memory (RAM)/internal memory (flash)/non-volatile memory (hardware)	512 MB / 4 GB / 128 KB
Program memory/data memory/non-volatile memory (software)	CODESYS V2: 16 MB / 64 MB / 128 KB; CODESYS V3: 32 MB / 128 MB / 128 KB
Number of modules per node (max.)	64
Input and output process image (internal) max.	1000 words/1000 words
Input and output process image (Modbus®) max.	CODESYS V2: 1000 words/1000 words; CODESYS V3: 32000 words/32000 words
Input and output process image (PROFIBUS) max.	244 bytes/244 bytes
Input and output process image (CAN) max.	2000 words/2000 words
Supply voltage (system)	24 VDC; via pluggable connector (CAGE CLAMP® connection); Derating must be observed!
Supply voltage (field)	24 VDC; Power supply via pluggable connector (CAGE CLAMP® connection); Transmission via power jumper contacts; Derating must be observed!
Derating	Derating (supply voltage): Ambient temperatures under laboratory conditions: (-25 ... +30 %); for -40 ... +55 °C: 24 V (-25 ... +20 %); for +55 ... +70 °C: 24 V (-25 ... +10 %); Lower limit in all temperature ranges: -27.5 % (including 15 % residual ripple)
Input current (typ.) at nominal load (24 V)	550 mA
Total current (system supply)	1700 mA
Ambient temperature (operation)	-40 ... +70 °C
Dimensions W x H x D	(112 x 100 x 71.9) mm
Approvals	CE; Marine; OrdLoc/HazLoc
For data sheet and additional information, see:	wago.com/750-8216/040-000

Product Expansions	Item no.
Runtime; BACnet; 300; Single License	2759-283/211-1000
Runtime; DNP3 Master; M; Single License	2759-2293/211-1000
Runtime; IEC60870 Slave; Single License	2759-290/211-1000
Runtime; DNP3 Slave; Single License	2759-2290/211-1000
Runtime; IEC60870 Master; M; Single License	2759-293/211-1000
Runtime; IEC61850 Client; M; Single License	2759-2243/211-1000
Runtime; IEC61850 Server; Single License	2759-2240/211-1000
Accessories	Item no.
Memory Card SD; SLC-NAND; 2 GByte; Temperature from -40 to 90 °C	758-879/000-001
Memory Card SD; pSLC-NAND; 8 GB; Temperature range: -40 to 90 °C	758-879/000-2108



Basic Controllers 100

Controllers PFC100/PFC200

- Maximum performance in a minimum space
- Also programmable in high-level languages based on Linux®
- Security packages with SSH and SSL/TLS
- Runtime system for CODESYS V3

◀◀ Section 6.1

Controllers PFC200 XTR

- The advantages of WAGO's PFC Controllers combined with the capabilities for extreme environments:
- High processing speed
- Multiple interfaces
- eXTRemely robust and maintenance-free

◀ Section 6.2

Basic Controllers 100

- Freely programmable per IEC 61131-3 with CODESYS V3
- HTML-5-based Web visualization
- Syslog in compliance with RFC 5424 and role-based user management (RBAC)
- Large amount of memory for projects and data

Controllers 750

- Controllers for all common fieldbus systems
- Programmable per IEC 61131-3
- Readily combines with the modules of the WAGO I/O System 750

Section 6.4 ▶

Controllers 750 XTR

- For demanding applications in which the following are critical:
- Extreme temperature resistance
- Immunity to electromagnetic interference and impulse voltages
- Vibration and shock resistance

Section 6.5 ▶▶

Starter Kits

For the entry into the most diverse application possibilities

IoT Boxes

Integrating machines and plants into the Internet of Things

Section 6.6 ▶▶▶

Basic Controllers 100

Contents

	Page
General Product Information	144
Interfaces and Types	145
Item Number Key	145
Installation Instructions	146
Standards and Rated Conditions	147
Approvals	147



CPU	Modbus (TCP, UDP)	Description	Item No.	
32 bits	M/S	Basic Controller 100; 2 x ETHERNET	750-8001	148
	M/S	Basic Controller 100; 2 x ETHERNET; ECO	750-8000	149

M: Master, S: Slave

Basic Controllers 100

General Product Information

Basic Controllers 100:

The Basic Controllers 100 primarily use the manufacturer-independent IEC 61131-3 engineering system CODESYS V3. Integrated standard editors (FBD, LD, ST, AS) make it easy to create extensive applications. All the advantages of object-oriented programming can be used to their full extent.

Seamlessly integrated communication protocols (OPC UA Client/Server/PubSub, Modbus TCP Master/Slave, EtherNet/IP™ Scanner/Adapter and MQTT) are supported, along with advanced HTML5-based web visualization.

The Basic Controllers 100 feature a new role-based user management and support the TLS1.3 encryption protocol. Both RFC 5424-compliant syslog and the SFTP encrypted transfer protocol – along with https – are standard features.

Link between Process Data and IT Application

WAGO's controllers ideally combine real-time requirements with IT functionality. They support Modbus/TCP and EtherNet/IP™ for use in industrial environments. HTTP; HTTPS, SNMP, FTP, BootP, DHCP, DNS and other protocols simplify integration into IT environments. Integrated Web pages and Web-based visualization provide IT applications with real-time process data.

Furthermore, the controllers incorporate library functions for email, SOAP, ASP, IP configuration, ETHERNET sockets and file system.

Worldwide Approvals

International approvals for building and industrial automation, as well as the process and marine industries, guarantee worldwide use. These approvals even include the harsh operating conditions that ATEX, BR-Ex, IECEx, UL508, UL ANSI/ISA, AEx and numerous other marine certifications cover.

Modular and Expandable

With the WAGO I/O System 750, the Basic Controllers can expand to almost any input/output interface. A modular, DIN-rail-mount design permits easy installation, expansion and modification of the I/O node without tools.

The straightforward design prevents installation errors. Additionally, proven CAGE CLAMP® technology ensures that all connections made in the field are quick, vibration-proof and maintenance-free. Depending on the I/O modules' granularity, the field level can be directly wired using 1-, 2-, 3- or 4-conductor technology.

Maximum Reliability and Ruggedness

The WAGO I/O System is engineered and tested for use in the most demanding environments (e.g., temperature cycling, shock/vibration loading and ESD) according to the highest standards. Spring pressure connection technology guarantees continuous operation. Integrated QA measures in the production process and 100% function testing ensure consistent quality.



Advantages:

- Freely programmable per IEC 61131-3 with CODESYS V3
- HTML5-based Web visualization
- Syslog in compliance with RFC 5424 and role-based user management (RBAC)
- Large amount of memory for projects and data

Basic Controllers 100 Interfaces and Types

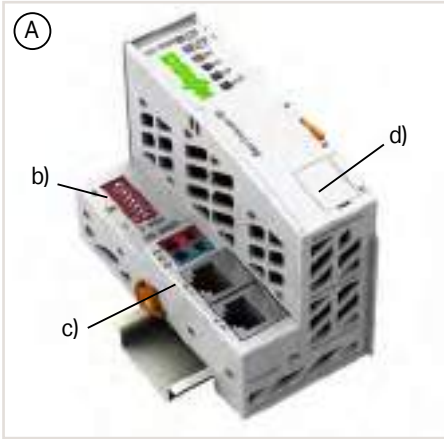

- Technical differences on the connection level; optional addressing switch (b) and fieldbus interface (c)
- Service interface (d)

Housing Design Eco (A)

- W x H x D (mm): 49.5 x 96.8 x 71.9

Housing Design (B)

- Includes a supply module (a) to power downstream I/O modules
- SD card slot for external storage media (e)
- W x H x D (mm): 61.5 x 100 x 71.9

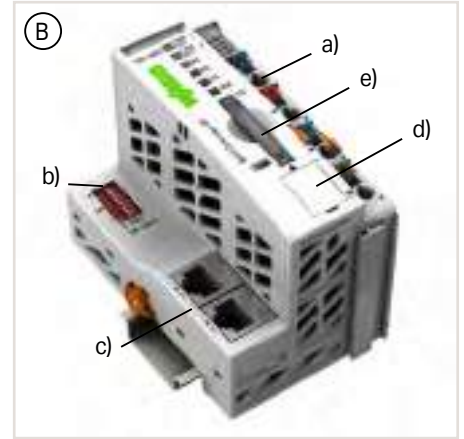

Item Number Key

Explanation of an item number key's components:

Item No. : 750-800x		
0:	32 bits	ETHERNET; Modbus TCP; Eco
1:	32 bits	ETHERNET; Modbus TCP; SD card slot

Basic Controllers 100 Installation Instructions

Power Supply

The internal electronics are powered by the controller. The field-side power supply is electrically isolated via the supply module on the controller or a separate power supply module. This division enables a separate supply for sensors and actuators. Snapping the I/O modules together automatically routes the supply voltages (system power supply 5 VDC via the data contacts and field supply via the optional power jumper contacts). Supply modules with diagnostics also enable power supply monitoring. This ensures a flexible and customized supply configuration for a fieldbus node. Power supply to the electronics is limited by a maximum value. This value is dependent on the controller used. If the sum of the internal current demand of all the I/O modules should exceed this value, an additional system supply module is necessary. Furthermore, the current consumed for field-side supply must not exceed 10 A. A variety of power supply modules allows re-feeding, creating potential groups and implementing emergency stops.

Interference-Free in Safety-Related Applications

To easily and safely perform a cost-effective and centralized deactivation of complete actuator groups, the actuator's power supply can be switched off using a safety switching device. This can either be performed for each individual actuator or by turning off the power supply to a group of control outputs. In the event of failure, ensure that no interference from other current or power circuits occurs – even when the control voltage is switched off – so the defined safety function properties (logic and time response) remain unchanged.

Some modules are designed to provide interference-free safety functionality. These modules comply with safety requirements up to Category 4 of DIN EN ISO 13849-1:2007. Safety category and performance level depend solely on the safety components and their wiring.

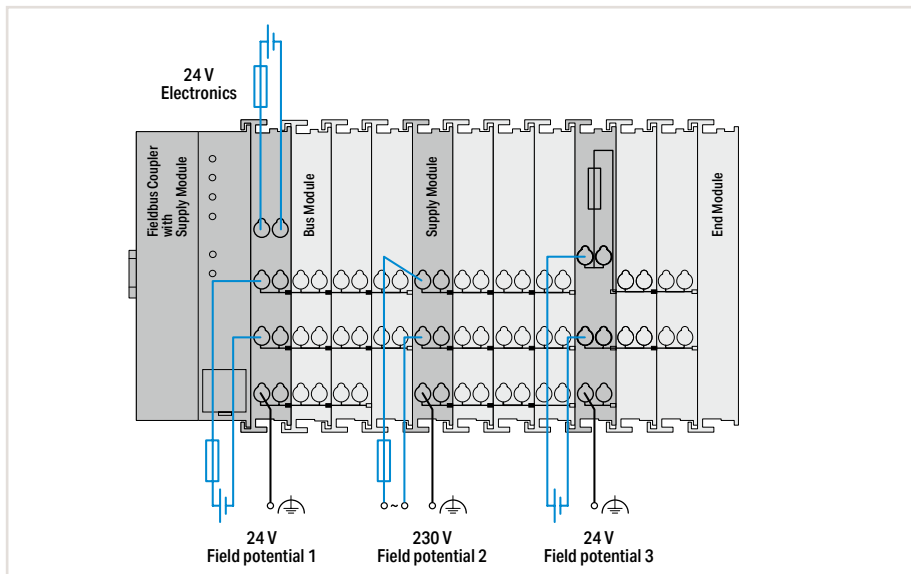

Notice:

WAGO's interference-free I/O modules are not a component of the safety function and do not replace the safety switching device! When using the components in safety functions, the corresponding notes must be observed in the relevant manual.

Notes:

Additional steps must be implemented based on where the I/O system is installed:

Specific power and field-side power supply filters (750-624 or 750-626) are required for marine and onshore/offshore applications.

Additionally, both a supply module and a field-side power supply filter are recommended when operating intrinsically safe Ex i modules for marine and onshore/offshore applications.

When operating safety-related I/O modules, PELV/SELV power supply units must be used for 24 VDC supply of electronics and field. Furthermore, specific power and field-side power supply filters (750-626) must be provided.

Please refer to the manual for details about the power supply's design.

A specific supply module (750-606) is required to operate intrinsically safe Ex i modules.

6.3

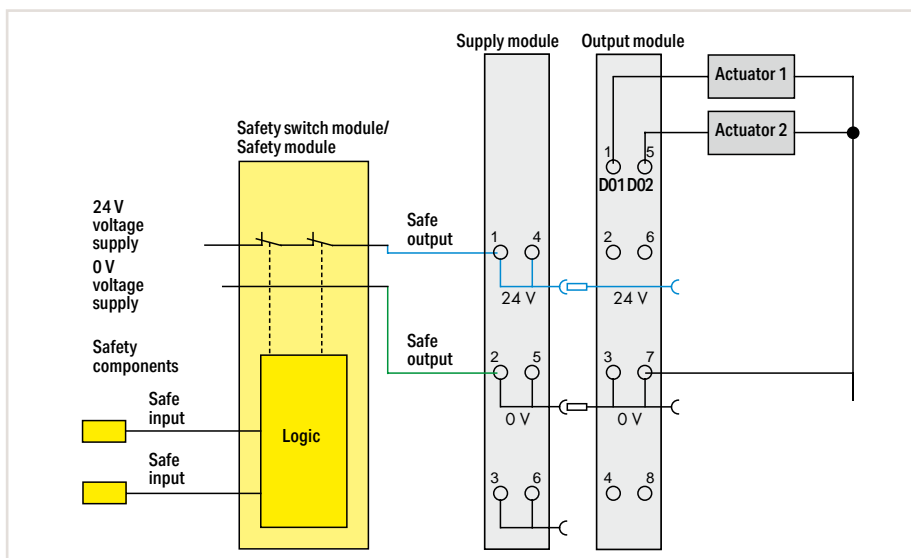

Example: 2-channel, double-pole power supply disconnection

Basic Controllers 100

Standards and Rated Conditions

General Technical Data	
System supply voltage	24 VDC (-25 % ... +30 %); via pluggable connector (CAGE CLAMP® connection)
Isolation	500 V (system/supply)
Surrounding air temperature (operation)	0 ... +55 °C
Surrounding air temperature (storage)	-25 ... +85 °C
Relative humidity	95 % (non-condensing)
Operating altitude	without temperature derating: 0 ... 2000 m; with temperature derating: 2000 ... 5000 m (0.5 K/100 m); 5000 m (max.)
Pollution degree	2 per IEC 61131-2
Vibration resistance	04g per IEC 60068-2-6
Shock resistance	15g per IEC 60068-2-27
EMC immunity to interference	Per EN 61000-6-2; marine applications
EMC emission of interference	Per EN 61000-6-3; marine applications
Protection class	IP20
Mounting position	any
Mounting type	DIN-35 rail mounting
Housing material	Polycarbonate; polyamide 6.6
Exposure to pollutants	Per IEC 60068-2-42 and IEC 60068-2-43
Permissible SO ₂ contaminant concentration at a relative humidity < 75 %	25 ppm
Permissible H ₂ S contaminant concentration at a relative humidity < 75 %	10 ppm
Connection technology: system supply	2 x CAGE CLAMP®
Solid conductor	0.08 ... 2.5 mm ² / 28 ... 14 AWG
Fine-stranded conductor	0.08 ... 2.5 mm ² / 28 ... 14 AWG
Strip length	8 ... 9 mm / 0.31 ... 0.35 inches
Current carrying capacity (power jumper contacts)	10 A

Approvals

For approvals overview (item comparison), see Section 14 (Technical Section) or visit www.wago.com.



Cables and connectors	Page 680
Communication	Page 678
DIN-rail	Page 716
Marking	Page 714
Shield termination	Page 708
Software	Page 36
System enclosure	Page 693

Basic Controller 100 ▶ Modbus TCP; SD card slot



750-8001

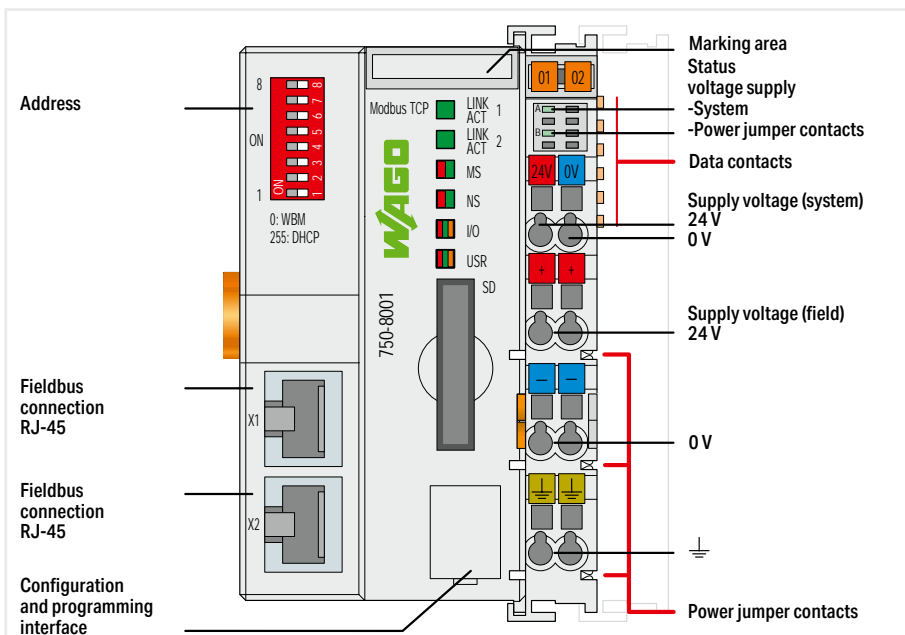

Version	Standard
Item no.	750-8001
Order Text	Basic Controller 100; 2ETH
Technical data	
Communication	Modbus (TCP, UDP)
ETHERNET protocols	HTTP(S); BootP; DHCP; DNS; SNTP; SFTP; SNMP (V2 & V3); TLS1.3 Syslog
Connection technology: communication/fieldbus	Modbus (TCP, UDP); 2 x RJ-45
Baud rate	10/100 Mbit/s
Visualization	Webserver mit integrierten RBAC (Role Based Access Control)
Programming environment	CODESYS V3.5
Type of memory card	SD and SDHC up to 32 GB (all guaranteed properties only valid with WAGO Memory Card)
Program memory/data memory/non-volatile memory (software)	16 MB / 32 MB / 128 KB
Number of modules per node (max.)	250
Input and output process image (fieldbus) max.	1020 words/1020 words
Supply voltage (system)	24 VDC (-25 ... +30 %); via pluggable connector (CAGE CLAMP® connection)
Supply voltage (field)	24 VDC (-25 ... +30 %); via power jumper contacts
Input current (typ.) at nominal load (24 V)	500 mA
Current consumption (5 V system supply)	440 mA
Total current (system supply)	1700 mA
Ambient temperature (operation)	0 ... +55 °C
Dimensions W x H x D	(61.5 x 100 x 71.9) mm
Approvals	CE
For data sheet and additional information, see:	wago.com/750-8001

Basic Controller 100 ▶ Modbus TCP; ECO



750-8000

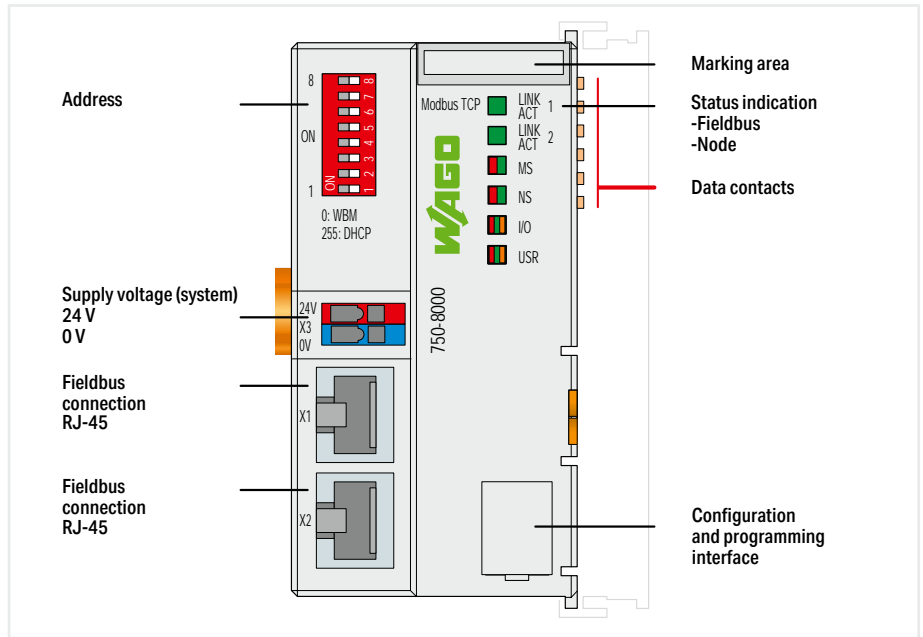

Version	Standard
Item no.	750-8000
Order Text	Basic Controller 100; 2ETH; ECO

Technical data	
Communication	Modbus (TCP, UDP)
ETHERNET protocols	HTTP(S); BootP; DHCP; DNS; SNTP; SFTP; SNMP (V2 & V3); TLS1.3 Syslog
Connection technology: communication/fieldbus	Modbus (TCP, UDP); 2 x RJ-45
Baud rate	10/100 Mbit/s
Visualization	Webserver mit integrierten RBAC (Role Based Access Control)
Programming environment	CODESYS V3.5
Program memory/data memory/non-volatile memory (software)	16 MB / 16 MB / 64 KB
Number of modules per node (max.)	250
Input and output process image (fieldbus) max.	1020 words/1020 words
Supply voltage (system)	24 VDC (-25 ... +30 %); via pluggable connector
Input current (typ.) at nominal load (24 V)	300 mA
Current consumption (5 V system supply)	390 mA
Total current (system supply)	700 mA
Ambient temperature (operation)	0 ... +55 °C
Dimensions W x H x D	(49.5 x 96.8 x 71.9) mm
Approvals	CE
For data sheet and additional information, see:	wago.com/750-8000



Controllers 750

Controllers PFC100/PFC200

- Maximum performance in a minimum space
- Also programmable in high-level languages based on Linux®
- Security packages with SSH and SSL/TLS
- Runtime system for CODESYS V3

◀◀ Section 6.1

Controllers PFC200 XTR

- The advantages of WAGO's PFC Controllers combined with the capabilities for extreme environments:
- High processing speed
- Multiple interfaces
- eXTRemely robust and maintenance-free

◀◀ Section 6.2

Basic Controllers 100

- Freely programmable per IEC 61131-3 with CODESYS V3
- HTML-5-based Web visualization
- Syslog in compliance with RFC 5424 and role-based user management (RBAC)
- Large amount of memory for projects and data

◀ Section 6.3

Controllers 750

- Controllers for all common fieldbus systems
- Programmable per IEC 61131-3
- Readily combines with the modules of the WAGO I/O System 750

Controllers 750 XTR

- For demanding applications in which the following are critical:
- Extreme temperature resistance
- Immunity to electromagnetic interference and impulse voltages
- Vibration and shock resistance

Section 6.5 ▶

Starter Kits

For the entry into the most diverse application possibilities













IoT Boxes

Integrating machines and plants into the Internet of Things

Section 6.6 ▶▶

Controllers 750 Contents

	Page
General Product Information	152
Variants	153
Interfaces and Types	153
Item Number Key	153
Installation Instructions	154
Standards and Rated Conditions	155
Approvals	155

	CPU	ETHERNET									Description	Item No.				
		Modbus (TCP, UDP)	EtherNet/IP™	BACnet/IP	KNX IP	Modbus RTU	Telecontrol Protocols	BACnet MS/TP	DeviceNet	PROFIBUS		CANopen	Standard		Extended Temperature	
	32 bits	M/S											Controller Modbus TCP; 4th Generation; 2 x ETHERNET, SD Card Slot	750-890	750-890/025-000	156
	32 bits	M/S					x						Controller Modbus TCP; 4th Generation; 2 x ETHERNET, SD Card Slot; Telecontrol Technology; Ext. Temperature		750-890/025-001 750-890/025-002	156
	32 bits	M/S											Controller Modbus TCP; 4th Generation; 2 x ETHERNET	750-891		157
	32 bits	M/S											Controller Modbus TCP; 4th Generation; ECO	750-862		158
	32 bits	M/S	S										Controller EtherNet/IP™; 4th Generation; 2 x ETHERNET, SD Card Slot	750-893		159
	32 bits	M/S	S										Controller EtherNet/IP™; 4th Generation; 2 x ETHERNET; ECO	750-823		160
	16 bits	M/S											Controller ETHERNET; 1 st Generation	750-842		161
	16 bits	M/S											Controller ETHERNET; 1 st Generation; ECO	750-843		162
	32 bits	M/S		x									Controller BACnet/IP	750-832		163
	32 bits	M/S		x									Controller BACnet/IP; ECO	750-832/000-002		163
	32 bits	M/S							x				Controller BACnet MS/TP	750-829		164
	32 bits	M/S			x								Controller KNX/IP	750-889		165
	16 bits					x							Controller MODBUS; RS-485; 115.2 kBd	750-815/300-000	750-815/325-000	166
	16 bits					x							Controller MODBUS; RS-232; 115.2 kBd	750-816/300-000		167
	16 bits										S		Controller PROFIBUS Slave	750-833	750-833/025-000	168
	16 bits											x	Controller DeviceNet	750-806		169
	16 bits											M/S	Controller CANopen; 128/64 KB Program/ RAM; MCS	750-837		170
	16 bits											M/S	Controller CANopen; 640/832 KB Program/ RAM; MCS	750-837/021-000		170
	16 bits											M/S	Controller CANopen; 128/64 KB Program/ RAM; D-Sub	750-838		171
	16 bits											M/S	Controller CANopen; 640/832 KB Program/ RAM; D-Sub	750-838/021-000		171

M: Master, S: Slave

Controllers 750

General Product Information

Controllers 750: Open – Flexible – Compact

WAGO's controllers are ideal for a wide variety of applications ranging from industrial, process and building automation to measurement and data collection. Based on the fieldbus couplers for all standard fieldbus systems, they are programmable to IEC 61131-3. Direct connection to a wide range of I/O modules from the WAGO I/O System 750 provides perfect adaptation to any application.

Building Automation

Dedicated controllers for the BACnet/IP and KNX IP bus systems are ideal for building automation applications. The wide range of I/O modules allows integration of external systems such as lighting control (DALI), sun protection (SMI), wireless switches (EnOcean) and much more.

Marine and Onshore/Offshore Industries

International approvals coupled with industry-specific features permit use in marine applications and other harsh sectors. Addressing requirements inherent in specific industries and operating environments has enabled use on marine diesels and in the EMC-sensitive area of a vessel's bridge. Because the requirements are significantly greater for both interference immunity and emission, along with superior mechanical performance in these sensitive areas, the WAGO I/O System will readily meet the needs of other industries.

Telecontrol Technology

Standardized IEC 60870-5, IEC 61850, IEC 61400-25 and DNP3 Telecontrol Protocols allow the Controllers 750 to be used in telecontrol applications.

Starter Kits

For a quick start, WAGO offers every customer the unique opportunity to purchase a starter kit that already contains all the components needed to begin programming and getting to know the controllers. For starter kits, see Section 6.6.

Link between Process Data and IT Application

WAGO's controllers ideally combine real-time requirements with IT functionality. They support Modbus/TCP and EtherNet/IP for use in industrial environments. HTTP; HTTPS, SNMP, FTP, BootP, DHCP, DNS and other protocols simplify integration into IT environments. Integrated Web pages and Web-based visualization provide IT applications with real-time process data. Furthermore, the controllers incorporate library functions for email, SOAP, ASP, IP configuration, ETHERNET sockets and file system.

Worldwide Approvals

International approvals for building and industrial automation, as well as the process and marine industries, guarantee worldwide use – even under harsh operating conditions. These recognitions include: ATEX, BR-Ex, IECEx, UL508, UL ANSI/ISA, AEx and numerous marine certifications.

Modular and Expandable

With the WAGO I/O System 750, the Controllers 750 can be expanded to almost any input/output interface. A modular, DIN-rail-mount design permits easy installation, expansion and modification of the I/O node without tools.

The straightforward design prevents installation errors. Additionally, proven CAGE CLAMP® technology ensures that all connections made in the field are quick, vibration-proof and maintenance-free. Depending on the I/O modules' granularity, the field level can be directly wired using 1-, 2-, 3- or 4-conductor technology.

Maximum Reliability and Ruggedness

The WAGO I/O System is engineered and tested for use in the most demanding environments (e.g., temperature cycling, shock/vibration loading and ESD) according to the highest standards. Spring pressure connection technology guarantees continuous operation. Integrated QA measures in the production process and 100% function testing ensure consistent quality.



Benefits:

- Controllers for all prominent fieldbus systems
- Industry-specific features
- Programmable via CODESYS 3 (IEC 61131-3)
- Expandable with the WAGO I/O System 750's comprehensive product range
- Extensive IT integration possibilities
- Tested and approved worldwide
- Maintenance-free

Controllers 750 Variants

Extended Temperature Range

Industrial automation technology is typically operated in temperatures ranging from 0°C to 55°C. However, there are applications that require an extended temperature range. Select controllers are available in an extended temperature range of -20°C to +60°C.



For extreme applications, where even this extended temperature range is not sufficient, the WAGO I/O System 750 XTR is available.

Interfaces and Types

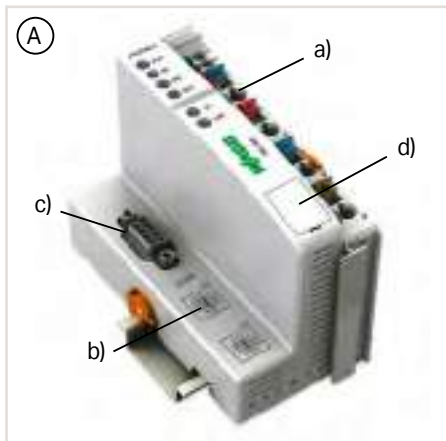

- Technical differences on the connection level; optional addressing switch (b) and fieldbus interface (c)
- Service interface (d)

Housing Design (A)

- Includes a supply module (a) to power downstream I/O modules
- W x H x D (mm): 50.5 x 100 x 71.1

Housing Design Eco (B)

- W x H x D (mm): 49.5 x 96.8 x 71.9

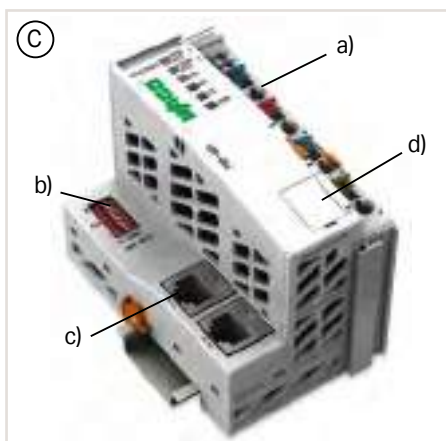
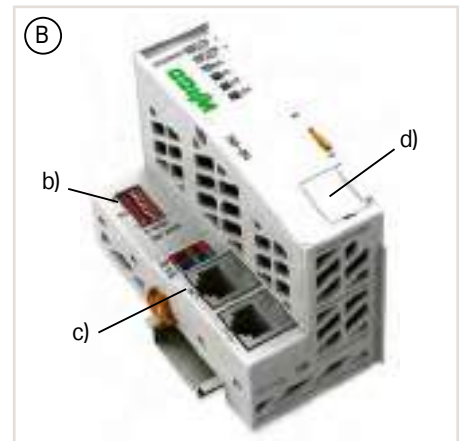

Housing Design (C)

- Includes a supply module (a) to power downstream I/O modules
- W x H x D (mm): 61.5 x 100 x 71.9

Housing Design (D)

- Includes a supply module (a) to power downstream I/O modules
- SD card slot for external storage media (e)
- W x H x D (mm): 61.5 x 100 x 71.9

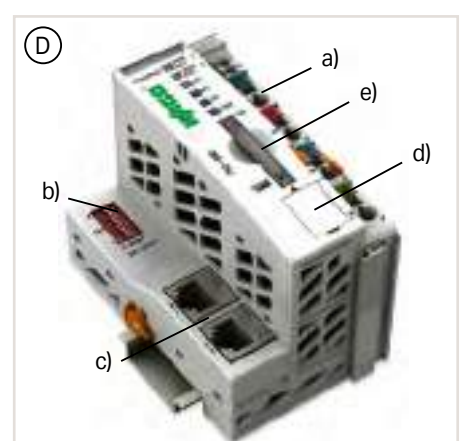

Item Number Key

Explanation of an item number key's components

Item No. : 750-8xx

0x, 1x: 16-bit CPU

3x, 4x: 16-bit CPU

6x: 32 bits

2x, 7x, 8x: 32-bit multitasking

INTERBUS, DeviceNet, Modbus

BACnet, PROFIBUS, CANopen, ETHERNET

ETHERNET Eco

ETHERNET, telecontrol technology, media redundancy,

BACnet, KNX IP

.../025-yyy: Extended temperature range (-20 ... +60 °C)

000: Standard, 001: Telecontrol technology, 002: Telecontrol technology Eco

Controllers 750 Installation Instructions

Power Supply

The internal electronics are powered by the controller. The field-side power supply is electrically isolated via the supply module on the controller or a separate power supply module. This division enables a separate supply for sensors and actuators. Snapping the I/O modules together automatically routes the supply voltages (system power supply 5 VDC via the data contacts and field supply via the optional power jumper contacts). Supply modules with diagnostics also enable power supply monitoring. This ensures a flexible and customized supply configuration for a fieldbus node. Power supply to the electronics is limited by a maximum value. This value is dependent on the controller used. If the sum of the internal current demand of all the I/O modules should exceed this value, an additional system supply module is necessary. Furthermore, the current consumed for field-side supply must not exceed 10 A. A variety of power supply modules allows re-feeding, creating potential groups and implementing emergency stops.

Interference-Free in Safety-Related Applications

To easily and safely perform a cost-effective and centralized deactivation of complete actuator groups, the actuator's power supply can be switched off using a safety switching device. This can either be performed for each individual actuator or by turning off the power supply to a group of control outputs. In the event of failure, ensure that no interference from other current or power circuits occurs – even when the control voltage is switched off – so the defined safety function properties (logic and time response) remain unchanged.

Some modules are designed to provide interference-free safety functionality. These modules comply with safety requirements up to Category 4 of DIN EN ISO 13849-1:2007. Safety category and performance level depend solely on the safety components and their wiring.

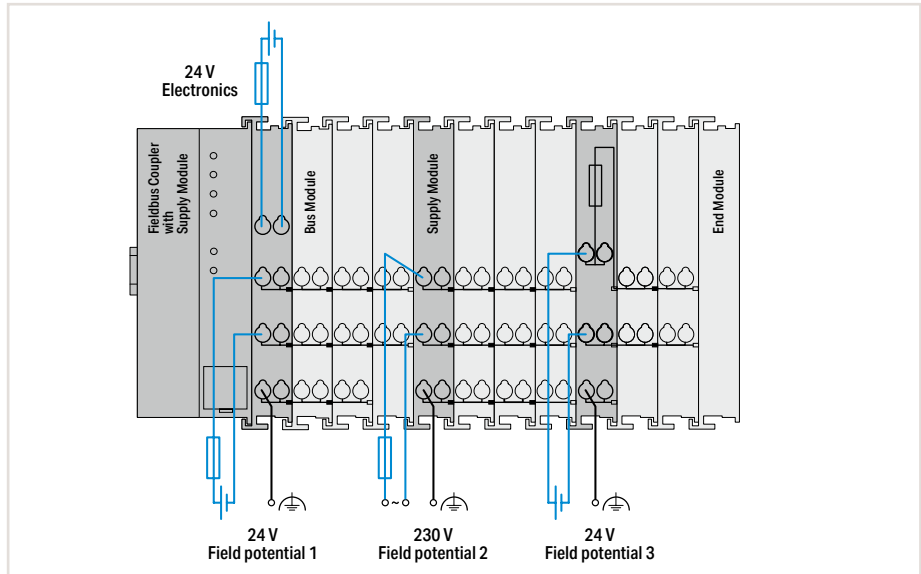

Notice:

WAGO's interference-free I/O modules are not a component of the safety function and do not replace the safety switching device! When using the components in safety functions, the corresponding notes must be observed in the relevant manual.

Notes:

Additional steps must be implemented based on where the I/O system is installed:

Specific power and field-side power supply filters (750-624 or 750-626) are required for marine and onshore/offshore applications.

A specific supply module (750-606) is required to operate intrinsically safe Ex i modules.

Additionally, both a supply module and a field-side power supply filter are recommended when operating intrinsically safe Ex i modules for marine and onshore/offshore applications.

When operating safety-related I/O modules, PELV/SELV power supply units must be used for 24 VDC supply of electronics and field. Furthermore, specific power and field-side power supply filters (750-626) must be provided.

Please refer to the manual for details about the power supply's design.

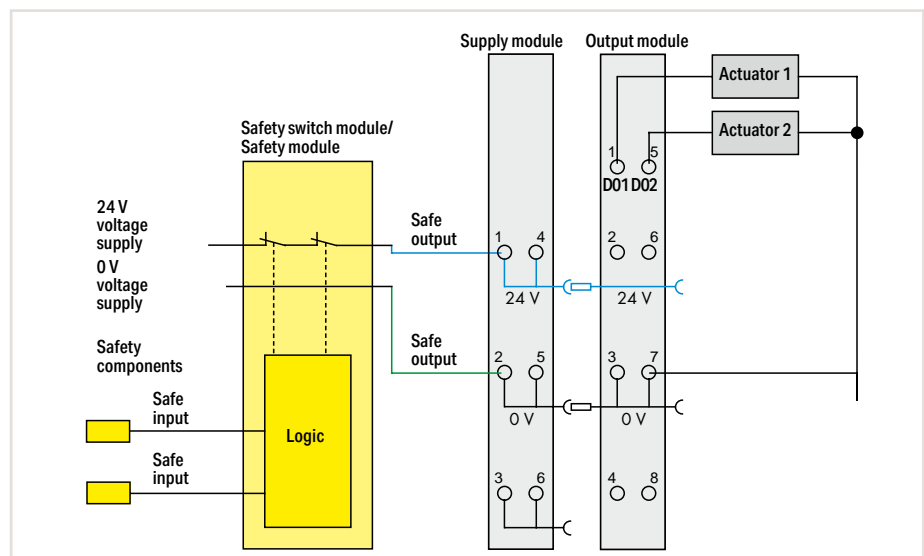

Example: 2-channel, double-pole power supply disconnection

Controller 750

Standards and Rated Conditions

General technical data	
Relative humidity (without condensation)	95 %
Operating altitude	without temperature derating: 0 ... 2000 m; with temperature derating: 2000 ... 5000 m (0.5 K/100 m); 5000 m (max.)
Pollution degree	2 per IEC 61131-2
Shock resistance	15g per IEC 60068-2-27
Protection type	IP20
Mounting position	any
Mounting type	DIN-35 rail
Housing material	Polycarbonate; polyamide 6.6
Exposure to pollutants	per IEC 60068-2-42 and IEC 60068-2-43
Permissible SO ₂ contaminant concentration at a relative humidity 75 %	25 ppm
Permissible H ₂ S contaminant concentration at a relative humidity 75 %	10 ppm
Connection technology: system supply	2 x CAGE CLAMP®
Solid conductor	0.08 ... 2.5 mm ² / 28 ... 14 AWG
Fine-stranded conductor	0.08 ... 2.5 mm ² / 28 ... 14 AWG
Strip length	8 ... 9 mm / 0.31 ... 0.35 inches

Approvals

For approvals overview (item comparison), see Section 14 (Technical Section) or visit www.wago.com.



Cables and connectors	Page 680
Communication	Page 678
DIN-rail	Page 716
Marking	Page 714
Shield termination	Page 708
Software	Page 36
System enclosure	Page 693

Controller 750 ▶ Modbus TCP; SD card slot



750-890

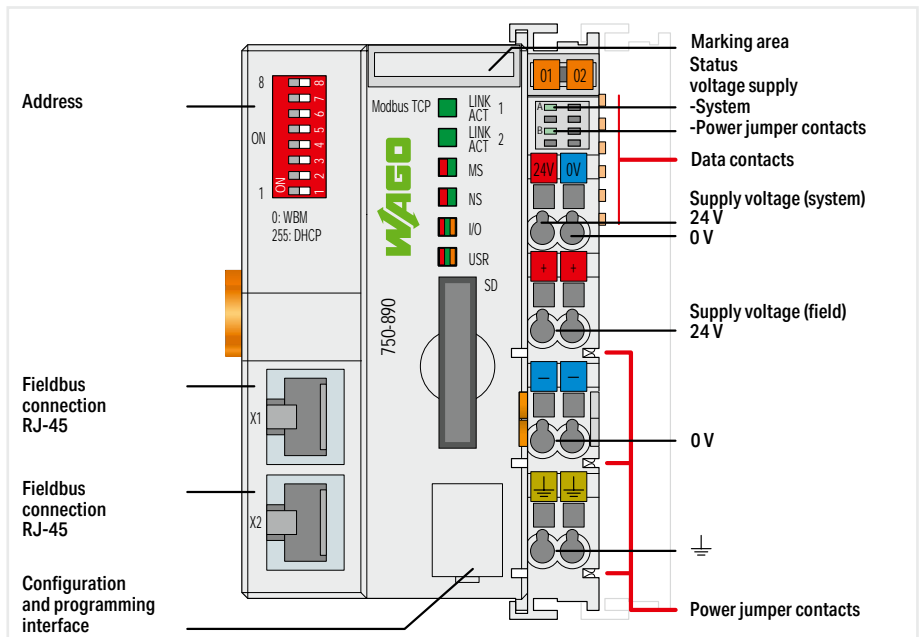

Version	Standard	ext. temperature	Telecontrol technology; ext. temperature	Telecontrol technology; ext. temperature; ECO
Item no.	750-890	750-890/025-000	750-890/025-001	750-890/025-002
Order Text	Controller Modbus TCP; G4; 2ETH SD	Controller Modbus TCP; G4; 2ETH SD; T	Controller Modbus TCP; G4; 2ETH SD; Tele; T	Controller Modbus TCP; G4; 2ETH SD; Tele; T; ECO

Technical data				
Communication	Modbus (TCP, UDP)		Modbus (TCP, UDP); Telecontrol protocols	
ETHERNET protocols	HTTP(S); BootP; DHCP; DNS; SNTP; FTP(S); SNMP			
Telecontrol protocols	-			
Telecontrol protocols	IEC 60870-5-101/-103/-104; IEC 61400-25; IEC 61850-7; DNP3			
Connection technology: communication/fieldbus	Modbus (TCP, UDP): 2 x RJ-45		Modbus (TCP, UDP): 2 x RJ-45; Telecontrol protocol IEC 60870-5-101/-103: 1 x Serial interface via I/O module; Telecontrol protocol IEC 60870-5-104: 1 x RJ-45; Telecontrol protocol IEC 61850: 1 x RJ-45; Telecontrol protocol DNP3: 1 x RJ-45	
Baud rate	10/100 Mbit/s			
Visualization	Web-Visu			
Programming environment	WAGO-I/O-PRO V2.3 (based on CODESYS V2.3)			
Type of memory card	SD and SDHC up to 32 GB (all guaranteed properties only valid with WAGO Memory Card)			
Program memory/data memory/non-volatile memory (software)	CODESYS V2: 8 MB / 8 MB / 32 KB			
Number of modules per node (max.)	250		4	
Input and output process image (fieldbus) max.	1020 words/1020 words			
Supply voltage (system)	24 VDC (-25 ... +30 %); via pluggable connector (CAGE CLAMP® connection)			
Supply voltage (field)	24 VDC (-25 ... +30 %); via power jumper contacts			
Input current (typ.) at nominal load (24 V)	500 mA			
Current consumption (5 V system supply)	440 mA			
Total current (system supply)	1700 mA			
Ambient temperature (operation)	0 ... +55 °C		-20 ... +60 °C	
Dimensions W x H x D	(61.5 x 100 x 71.9) mm			
Approvals	CE; Marine; OrdLoc/HazLoc; ATEX/IECEX			
For data sheet and additional information, see:	wago.com/750-890			

Accessories	Item no.	Item no.	Item no.	Item no.
Memory Card SD; SLC-NAND; 2 GByte; Temperature from -40 to 90 °C	758-879/000-001	758-879/000-001	758-879/000-001	758-879/000-001
Memory Card SD; pSLC-NAND; 8 GB; Temperature range: -40 to 90 °C	758-879/000-2108	758-879/000-2108	758-879/000-2108	758-879/000-2108

Controller 750 ▶ Modbus TCP



750-891

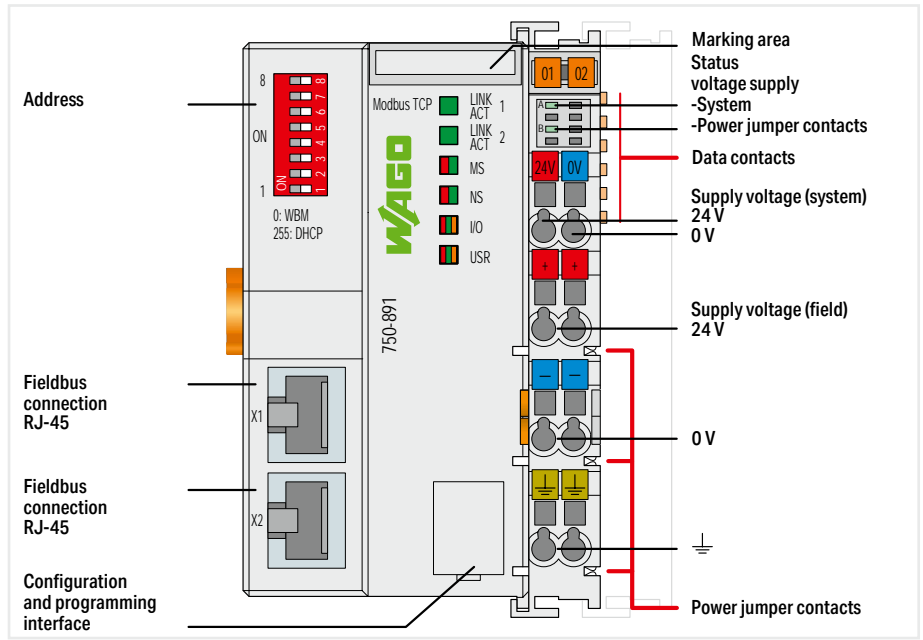

Version
Item no.
Order Text

Standard
750-891
Controller Modbus TCP; G4; 2ETH

Technical data
Communication
ETHERNET protocols
Connection technology: communication/fieldbus
Baud rate
Visualization
Programming environment
Program memory/data memory/non-volatile memory (software)
Number of modules per node (max.)
Input and output process image (fieldbus) max.
Supply voltage (system)
Supply voltage (field)
Input current (typ.) at nominal load (24 V)
Current consumption (5 V system supply)
Total current (system supply)
Ambient temperature (operation)
Dimensions W x H x D
Approvals
For data sheet and additional information, see:

Modbus (TCP, UDP)
HTTP(S); BootP; DHCP; DNS; SNTP; FTP(S); SNMP
Modbus (TCP, UDP); 2 x RJ-45
10/100 Mbit/s
Web-Visu
WAGO-I/O-PRO V2.3 (based on CODESYS V2.3)
CODESYS V2: 4 MB / 4 MB / 32 KB
250
1020 words/1020 words
24 VDC (-25 ... +30 %); via pluggable connector (CAGE CLAMP® connection)
24 VDC (-25 ... +30 %); via power jumper contacts
500 mA
390 mA
1700 mA
0 ... +55 °C
(61.5 x 100 x 71.9) mm
CE; Marine; OrdLoc/HazLoc; ATEX/IECEX
wago.com/750-891

Controller 750 ▶ Modbus TCP; ECO



750-862

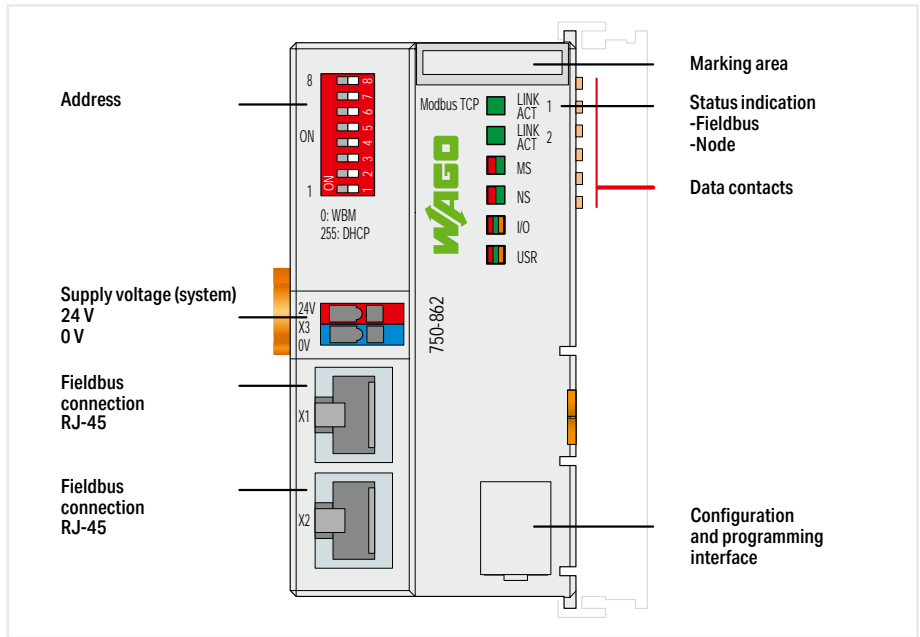

Version	Standard
Item no.	750-862
Order Text	Controller Modbus TCP; G4; 2ETH; ECO

Technical data	
Communication	Modbus (TCP, UDP)
ETHERNET protocols	HTTP(S); BootP; DHCP; DNS; SNTP; FTP(S); SNMP
Connection technology: communication/fieldbus	Modbus (TCP, UDP); 2 x RJ-45
Baud rate	10/100 Mbit/s
Visualization	Web server
Programming environment	WAGO-I/O-PRO V2.3 (based on CODESYS V2.3)
Program memory/data memory/non-volatile memory (software)	CODESYS V2: 2 MB / 2 MB / 16 KB
Number of modules per node (max.)	250
Input and output process image (fieldbus) max.	1020 words/1020 words
Supply voltage (system)	24 VDC (-25 ... +30 %); via pluggable connector
Input current (typ.) at nominal load (24 V)	300 mA
Current consumption (5 V system supply)	390 mA
Total current (system supply)	700 mA
Ambient temperature (operation)	0 ... +55 °C
Dimensions W x H x D	(49.5 x 96.8 x 71.9) mm
Approvals	CE; Marine; OrdLoc/HazLoc; ATEX/IECEX
For data sheet and additional information, see:	wago.com/750-862

Controller 750 ▶ EtherNet/IP™; SD card slot



750-893

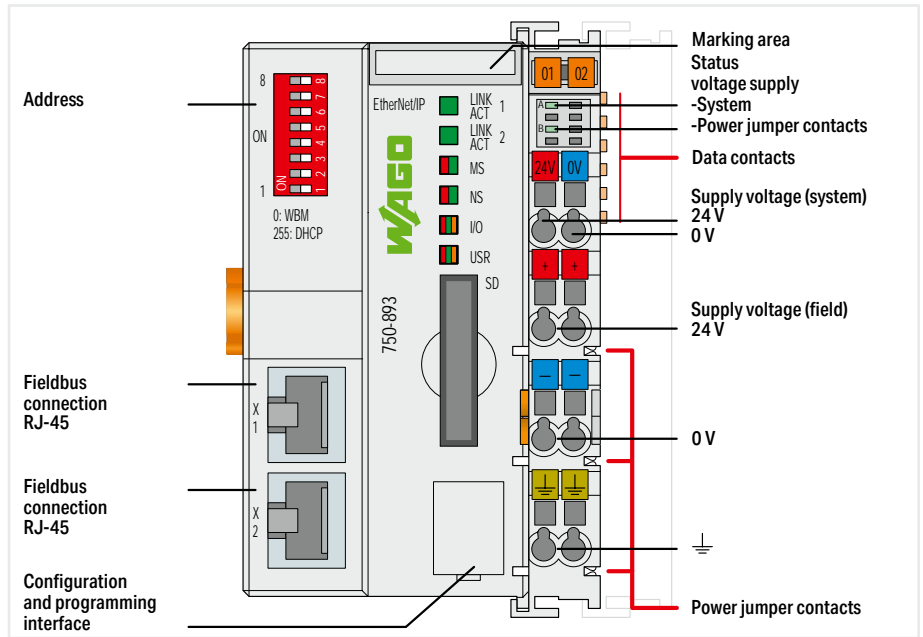

Version	Standard
Item no.	750-893
Order Text	Controller EtherNet/IP; SD
Technical data	
Communication	EtherNet/IP™
ETHERNET protocols	HTTP(S); BootP; DHCP; DNS; SNMP; FTP(S); SNMP
Connection technology: communication/fieldbus	EtherNet/IP™: 2 x RJ-45
Baud rate	10/100 Mbit/s
Visualization	Web-Visu
Programming environment	WAGO-I/O-PRO V2.3 (based on CODESYS V2.3)
Type of memory card	SD and SDHC up to 32 GB (all guaranteed properties only valid with WAGO Memory Card)
Program memory/data memory/non-volatile memory (software)	CODESYS V2: 8 MB / 8 MB / 32 KB
Number of modules per node (max.)	250
Input and output process image (fieldbus) max.	1020 words/1020 words
Supply voltage (system)	24 VDC (-25 ... +30 %); via pluggable connector (CAGE CLAMP® connection)
Supply voltage (field)	24 VDC (-25 ... +30 %); via power jumper contacts
Input current (typ.) at nominal load (24 V)	500 mA
Current consumption (5 V system supply)	440 mA
Total current (system supply)	1700 mA
Ambient temperature (operation)	0 ... +55 °C
Dimensions W x H x D	(61.5 x 100 x 71.9) mm
Approvals	CE; Marine; OrdLoc/HazLoc; ATEX/IECEx
For data sheet and additional information, see:	wago.com/750-893
Accessories	Item no.
Memory Card SD; SLC-NAND; 2 GByte; Temperature from -40 to 90 °C	758-879/000-001
Memory Card SD; pSLC-NAND; 8 GB; Temperature range: -40 to 90°C	758-879/000-2108

Controller 750 ▶ EtherNet/IP™; ECO



750-823

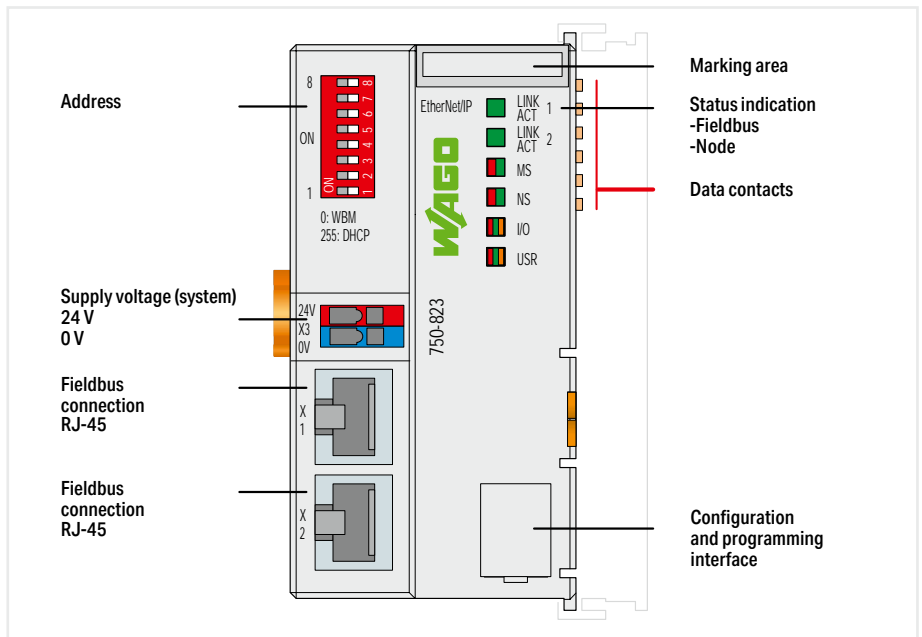

Version	Standard
Item no.	750-823
Order Text	Controller EtherNet/IP; ECO

Technical data	
Communication	EtherNet/IP™
ETHERNET protocols	HTTP(S); BootP; DHCP; DNS; SNMP; FTP(S); SNMP
Connection technology: communication/fieldbus	EtherNet/IP™: 2 x RJ-45
Baud rate	10/100 Mbit/s
Visualization	Web-Visu
Programming environment	WAGO-I/O-PRO V2.3 (based on CODESYS V2.3)
Program memory/data memory/non-volatile memory (software)	CODESYS V2: 2 MB / 2 MB / 32 KB
Number of modules per node (max.)	250
Input and output process image (fieldbus) max.	1020 words/1020 words
Supply voltage (system)	24 VDC (-25 ... +30 %); via pluggable connector
Input current (typ.) at nominal load (24 V)	300 mA
Current consumption (5 V system supply)	390 mA
Total current (system supply)	700 mA
Ambient temperature (operation)	0 ... +55 °C
Dimensions W x H x D	(49.5 x 96.8 x 71.9) mm
Approvals	CE; Marine; OrdLoc/HazLoc; ATEX/IECEX
For data sheet and additional information, see:	wago.com/750-823

Controller 750 ▶ ETHERNET



750-842

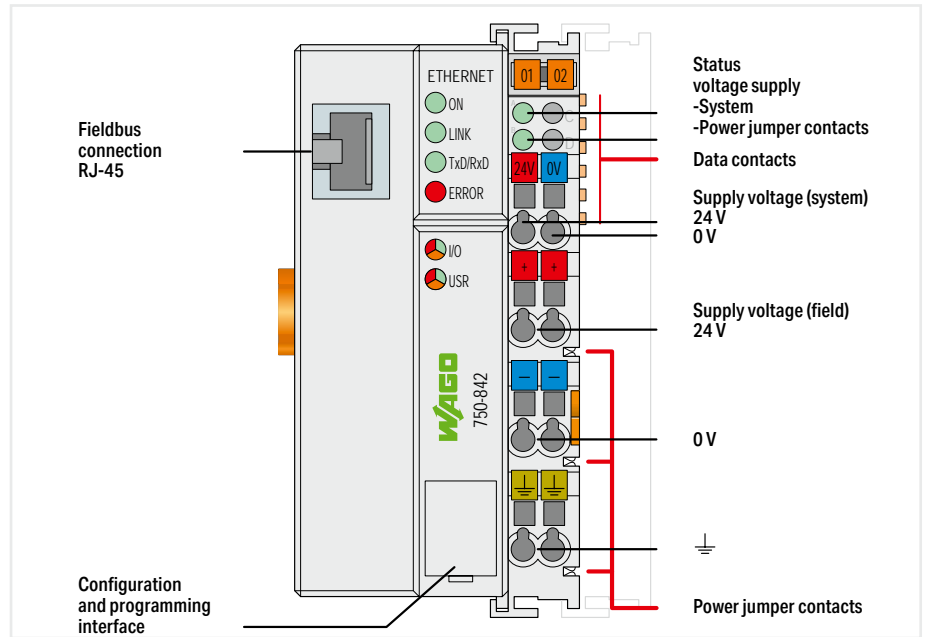

Version	Standard
Item no.	750-842
Order Text	Controller ETHERNET; G1
Technical data	
Communication	Modbus (TCP, UDP); ETHERNET
ETHERNET protocols	HTTP; BootP
Connection technology: communication/fieldbus	Modbus (TCP, UDP); 1 x RJ-45
Bus segment length (max.)	100 m
Baud rate	10 Mbit/s
Visualization	none
Programming environment	WAGO-I/O-PRO V2.3 (based on CODESYS V2.3)
Program memory/data memory/non-volatile memory (software)	CODESYS V2: 128 KB / 64 KB / 8 KB
Number of modules per node (max.)	64
Input and output process image (fieldbus) max.	512 bytes/512 bytes
Memory for fieldbus input variables (max.)	512 bytes
Memory for fieldbus output variables (max.)	512 bytes
Supply voltage (system)	24 VDC (-25 ... +30 %); via pluggable connector (CAGE CLAMP® connection)
Supply voltage (field)	24 VDC (-25 ... +30 %); via power jumper contacts
Input current (typ.) at nominal load (24 V)	500 mA
Current consumption (5 V system supply)	200 mA
Total current (system supply)	1800 mA
Ambient temperature (operation)	0 ... +55 °C
Dimensions W x H x D	(50.5 x 100 x 71.1) mm
Approvals	CE; Marine; OrdLoc/HazLoc; ATEX/IECEX
For data sheet and additional information, see:	wago.com/750-842

Controller 750 ► ETHERNET ECO



750-843

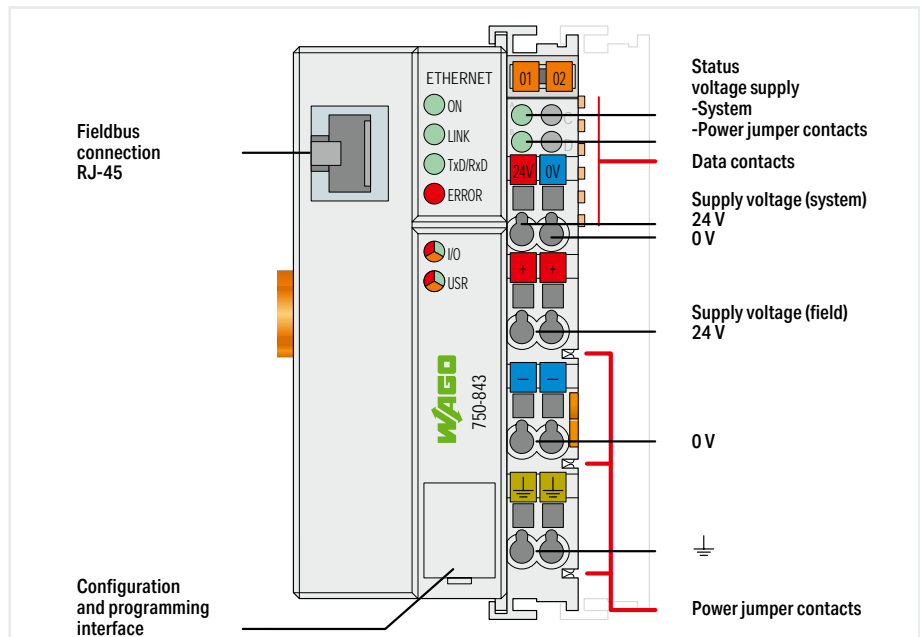

Version	Standard
Item no.	750-843
Order Text	Controller ETHERNET; G1; ECO
Technical data	
Communication	Modbus (TCP, UDP); ETHERNET
ETHERNET protocols	HTTP; BootP
Connection technology: communication/fieldbus	Modbus (TCP, UDP): 1 x RJ-45
Bus segment length (max.)	100 m
Baud rate	10 Mbit/s
Visualization	none
Programming environment	WAGO-I/O-PRO V2.3 (based on CODESYS V2.3)
Program memory/data memory/non-volatile memory (software)	CODESYS V2: 64 KB / 64 KB / 8 KB
Number of modules per node (max.)	64
Input and output process image (fieldbus) max.	512 bytes/512 bytes
Memory for fieldbus input variables (max.)	512 bytes
Memory for fieldbus output variables (max.)	512 bytes
Supply voltage (system)	24 VDC (-25 ... +30 %); via pluggable connector (CAGE CLAMP® connection)
Supply voltage (field)	24 VDC (-25 ... +30 %); via power jumper contacts
Input current (typ.) at nominal load (24 V)	500 mA
Current consumption (5 V system supply)	200 mA
Total current (system supply)	1800 mA
Ambient temperature (operation)	0 ... +55 °C
Dimensions W x H x D	(50.5 x 100 x 71.1) mm
Approvals	CE; Marine; OrdLoc/HazLoc; ATEX/IECEX

For data sheet and additional information, see: wago.com/750-843

Controller 750 ▶ BACnet/IP; SD card slot



750-832

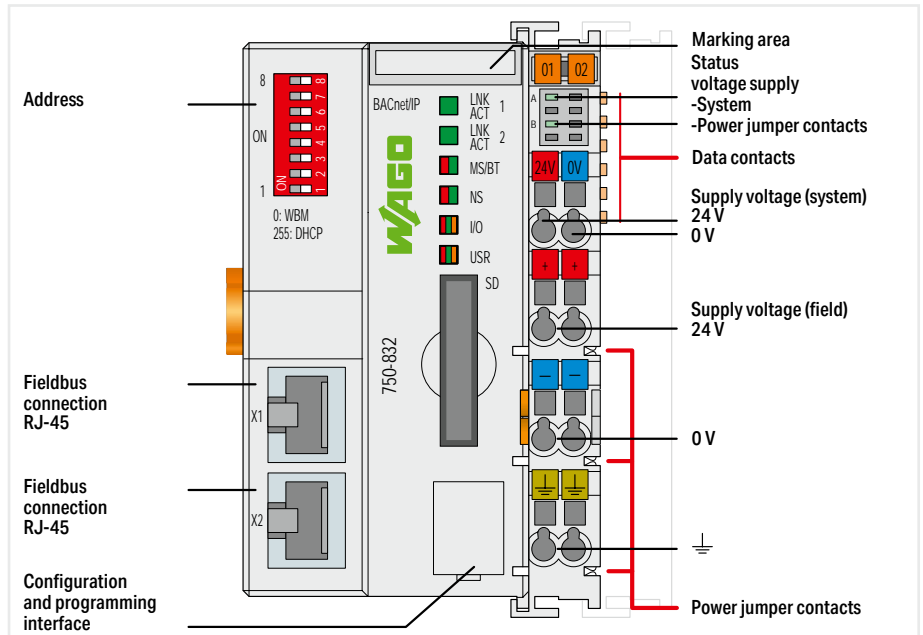

Version
Item no.
Order Text

Standard	ECO
750-832	750-832/000-002
Controller BACnet/IP; G4; 2xETH; SD	Controller BACnet/IP; G4; 2xETH; SD; ECO

Technical data
Communication
ETHERNET protocols
Connection technology: communication/fieldbus
Baud rate
Visualization
Programming environment
Type of memory card
Device-specific
Program memory/data memory/non-volatile memory (software)
Number of modules per node (max.)
Input and output process image (fieldbus) max.
Supply voltage (system)
Supply voltage (field)
Input current (typ.) at nominal load (24 V)
Current consumption (5 V system supply)
Total current (system supply)
Ambient temperature (operation)
Dimensions W x H x D
Approvals
For data sheet and additional information, see:

BACnet/IP; Modbus (TCP, UDP)
HTTP(S); BootP; DHCP; DNS; SNTP; FTP(S); SNMP
BACnet/IP: 2 x RJ-45; Modbus (TCP, UDP): 2 x RJ-45
10/100 Mbit/s
Web-Visu
WAGO-I/O-PRO V2.3 (based on CODESYS V2.3)
SD and SDHC up to 32 GB (all guaranteed properties only valid with WAGO Memory Card)
BACnet device profile: B-BC (BACnet building controller); BACnet revision: 12
CODESYS V2: 8 MB / 8 MB / 32 KB
250
1020 words/1020 words
24 VDC (-25 ... +30 %); via pluggable connector (CAGE CLAMP® connection)
24 VDC (-25 ... +30 %); via power jumper contacts
500 mA
440 mA
1700 mA
0 ... +55 °C
(61.5 x 100 x 71.9) mm
CE; Marine; OrdLoc/HazLoc; ATEX/IECEX; BACnet approvals: WSPCert certification; BTL listing
wago.com/750-832

Accessories
Memory Card SD; pSLC-NAND; 8 GB; Temperature range: -40 to 90°C

Item no.	Item no.
758-879/000-2108	758-879/000-2108
	750-832/000-002 Controllers support a maximum of 256 BACnet objects.

Controller 750 ► BACnet MS/TP



750-829

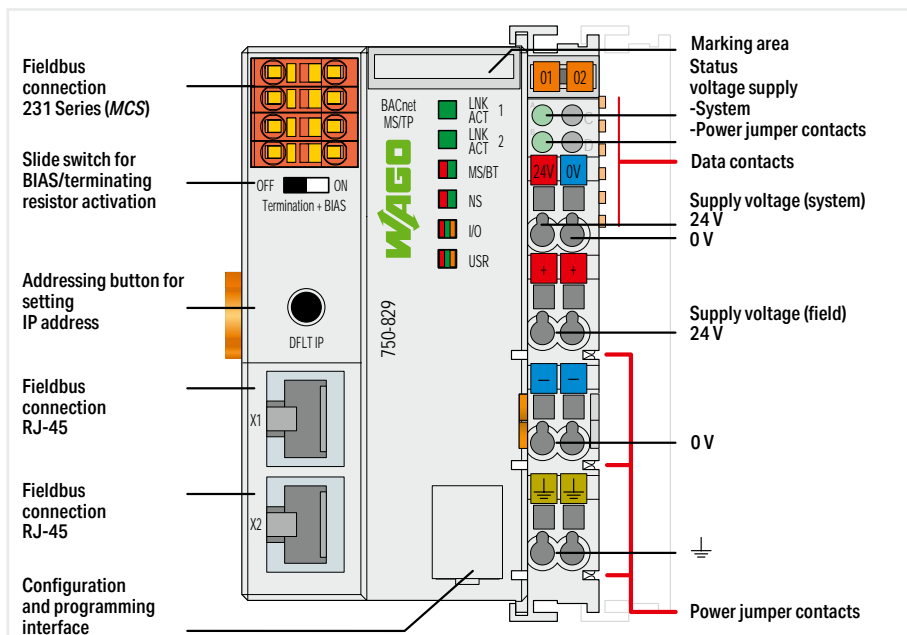

Version	Standard
Item no.	750-829
Order Text	Controller BACnet MS/TP
Technical data	
Communication	BACnet MS/TP; Modbus (TCP, UDP); ETHERNET
ETHERNET protocols	HTTP; BootP; DHCP; DNS; SNTP; FTP; SNMP; SMTP
Connection technology: communication/fieldbus	BACnet MS/TP: 1 x Male connector; 4-pole; Modbus (TCP, UDP): 2 x RJ-45
Bus segment length (max.)	BACnet MS/TP: 1200 m; Depends on baud rate/cable (per BACnet standard) 1200 m at ≤ 76800 baud; 1000 m at > 76800 baud; ETHERNET: 100 m
Baud rate	BACnet MS/TP: 38.4 kBd (9600, 19200, 38400*, 57600, 76800, 115200 Bd (per BACnet standard); * Factory setting)
Visualization	Web-Visu
Programming environment	WAGO-I/O-PRO V2.3 (based on CODESYS V2.3)
Device-specific	BACnet device profile: B-BC (BACnet building controller); BACnet revision: 1.7
Program memory/data memory/non-volatile memory (software)	CODESYS V2: 1024 KB / 1024 KB / 32 KB
Number of modules per node (max.)	99
Input and output process image (fieldbus) max.	1020 words/1020 words
Memory for fieldbus input variables (max.)	512 bytes
Memory for fieldbus output variables (max.)	512 bytes
Supply voltage (system)	24 VDC (-25 ... +30 %); via pluggable connector (CAGE CLAMP® connection)
Supply voltage (field)	24 VDC (-25 ... +30 %); via power jumper contacts
Input current (typ.) at nominal load (24 V)	500 mA
Current consumption (5 V system supply)	450 mA
Total current (system supply)	1700 mA
Ambient temperature (operation)	0 ... +55 °C
Dimensions W x H x D	(61.5 x 100 x 71.9) mm
Approvals	CE; OrdLoc/HazLoc
For data sheet and additional information, see:	wago.com/750-829

Controller 750 ▶ KNX/IP



750-889

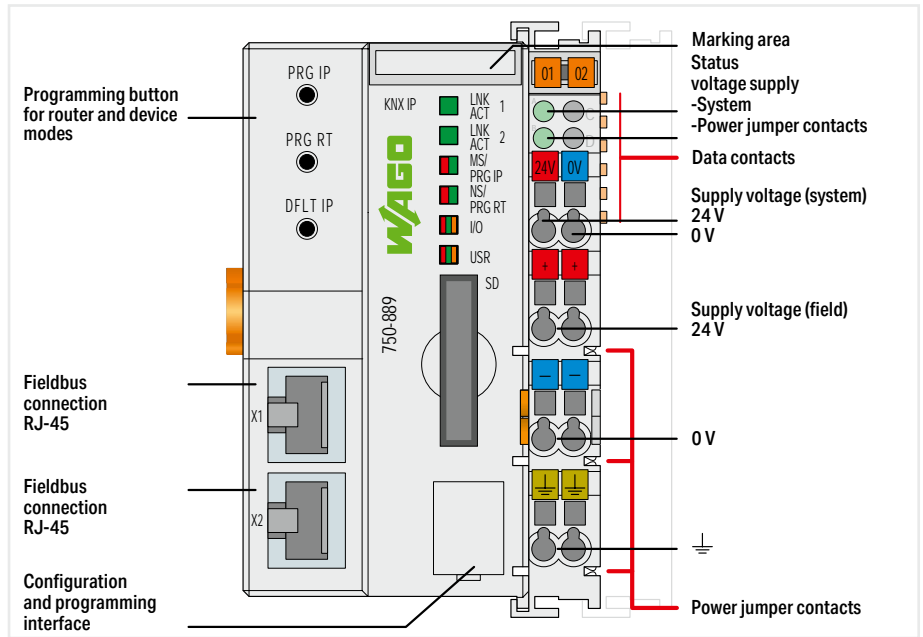

Version	Standard
Item no.	750-889
Order Text	Controller KNX/IP
Technical data	
Communication	KNX IP; Modbus (TCP, UDP); ETHERNET
ETHERNET protocols	HTTP; BootP; DHCP; DNS; AutoIP; SNMP; FTP; SNMP V3; SMTP
Connection technology: communication/fieldbus	KNX IP: 2 x RJ-45; Modbus (TCP, UDP): 2 x RJ-45
Bus segment length (max.)	100 m
Baud rate	10/100 Mbit/s
Visualization	Web-Visu
Programming environment	WAGO-I/O-PRO V2.3 (based on CODESYS V2.3)
Type of memory card	SD and SDHC up to 32 GB (all guaranteed properties only valid with WAGO Memory Card)
Device specification	KNX/TP1 Bus Specification: 1.0
Device-specific	Number of group addresses: 254; Number of communication objects: 253
Program memory/data memory/non-volatile memory (software)	CODESYS V2: 1024 KB / 1024 KB / 32 KB
Number of modules per node (max.)	250
Input and output process image (fieldbus) max.	1020 words/1020 words
Memory for fieldbus input variables (max.)	512 bytes
Memory for fieldbus output variables (max.)	512 bytes
Supply voltage (system)	24 VDC (-25 ... +30 %); via pluggable connector (CAGE CLAMP® connection)
Supply voltage (field)	24 VDC (-25 ... +30 %); via power jumper contacts
Input current (typ.) at nominal load (24 V)	500 mA
Current consumption (5 V system supply)	450 mA
Total current (system supply)	1700 mA
Ambient temperature (operation)	0 ... +55 °C
Dimensions W x H x D	(61.5 x 100 x 71.9) mm
KNX certified	IP Controller: 61/8316/08; IP Router: 61/8317/08
Approvals	CE, Marine, OrdLoc/HazLoc
For data sheet and additional information, see:	wago.com/750-889
Accessories	
Memory Card SD; SLC-NAND; 2 GByte; Temperature from -40 to 90 °C	758-879/000-001
Memory Card SD; pSLC-NAND; 8 GB; Temperature range: -40 to 90°C	758-879/000-2108

This controller can accommodate two KNX logic devices at the same time: programmable controller or KNX router in conjunction with KNX/EIB/TP1 module. Commissioning (KNX-side): via ETS plug-in, 2 programming buttons

Controller 750 ► MODBUS; RS-485; 115.2 kBd



750-815/300-000

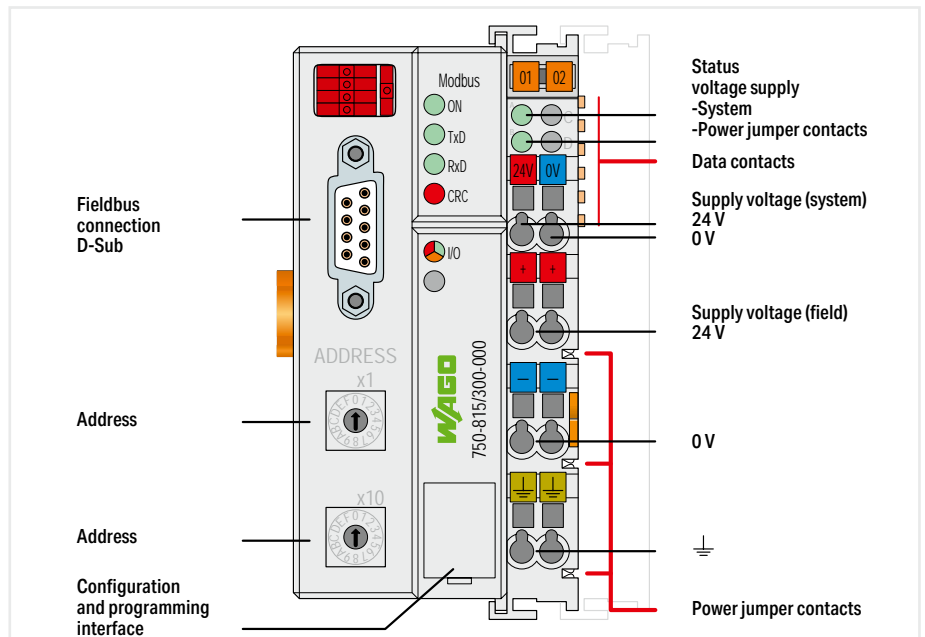

Version	Standard	ext. temperature
Item no.	750-815/300-000	750-815/325-000
Order Text	Controller MODBUS; RS485; 115.2kBd	Controller MODBUS; RS485; 115.2kBd; T

Technical data		
Communication	Modbus® RTU	
Connection technology: communication/fieldbus	Modbus® RTU: 1 x D-sub 9 socket	
Bus segment length (max.)	1200 m	
Baud rate	150 Bd ... 115.2 kBd	
Number of fieldbus nodes on master (max.)	247	
Visualization	none	
Programming environment	WAGO-I/O-PRO V2.3 (based on CODESYS V2.3)	
Program memory/data memory/non-volatile memory (software)	CODESYS V2: 32 KB / 32 KB / 8 KB	
Number of modules per node (max.)	64	
Input and output process image (fieldbus) max.	1024 bytes/1024 bytes	
Memory for fieldbus input variables (max.)	512 bytes	
Memory for fieldbus output variables (max.)	512 bytes	
Supply voltage (system)	24 VDC (-25 ... +30 %); via pluggable connector (CAGE CLAMP® connection)	
Supply voltage (field)	24 VDC (-25 ... +30 %); via power jumper contacts	
Input current (typ.) at nominal load (24 V)	500 mA	
Current consumption (5 V system supply)	350 mA	
Total current (system supply)	1650 mA	
Ambient temperature (operation)	0 ... +55 °C	-20 ... +60 °C
Dimensions W x H x D	(50.5 x 100 x 71.1) mm	
Approvals	CE; Marine; OrdLoc/HazLoc; ATEX/IECEX	
For data sheet and additional information, see:	wago.com/750-815/300-000	

Controller 750 ► MODBUS; RS-232; 115.2 kBd



750-816/300-000

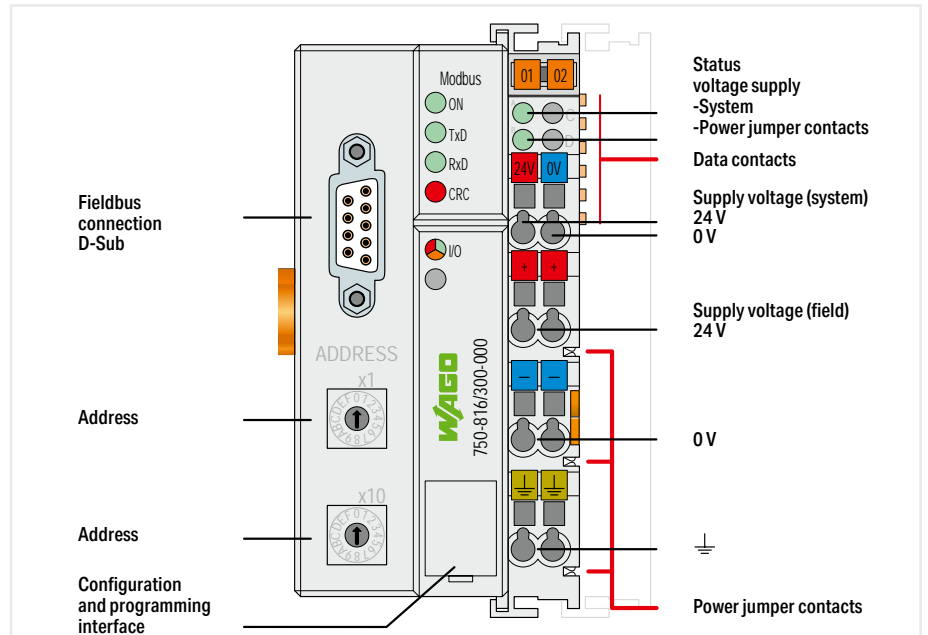

Version	Standard
Item no.	750-816/300-000
Order Text	Controller MODBUS; RS232; 115.2kBd
Technical data	
Communication	Modbus® RTU
Connection technology: communication/fieldbus	Modbus® RTU: 1 x D-sub 9 socket
Bus segment length (max.)	1200 m
Baud rate	150 Bd ... 115.2 kBd
Number of fieldbus nodes on master (max.)	247
Visualization	none
Programming environment	WAGO-I/O-PRO V2.3 (based on CODESYS V2.3)
Program memory/data memory/non-volatile memory (software)	CODESYS V2: 32 KB / 32 KB / 8 KB
Number of modules per node (max.)	64
Input and output process image (fieldbus) max.	1024 bytes/1024 bytes
Memory for fieldbus input variables (max.)	512 bytes
Memory for fieldbus output variables (max.)	512 bytes
Supply voltage (system)	24 VDC (-25 ... +30 %); via pluggable connector (CAGE CLAMP® connection)
Supply voltage (field)	24 VDC (-25 ... +30 %); via power jumper contacts
Input current (typ.) at nominal load (24 V)	500 mA
Current consumption (5 V system supply)	350 mA
Total current (system supply)	1650 mA
Ambient temperature (operation)	0 ... +55 °C
Dimensions W x H x D	(50.5 x 100 x 71.1) mm
Approvals	CE, Marine, OrdLoc/HazLoc, ATEX/IECEx
For data sheet and additional information, see:	wago.com/750-816/300-000

Controller 750 ▶ PROFIBUS slave



750-833

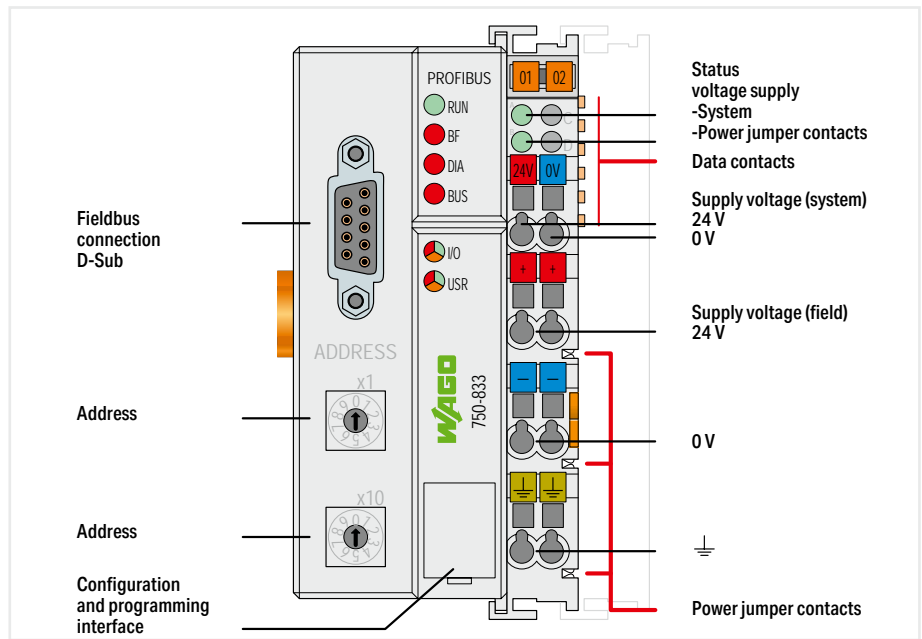

Version	Standard	ext. temperature
Item no.	750-833	750-833/025-000
Order Text	Controller PROFIBUS Slave	Controller PROFIBUS Slave; T

Technical data	PROFIBUS	
Communication	PROFIBUS: 1 x D-sub 9 socket	
Connection technology: communication/fieldbus	1200 m	
Bus segment length (max.)	9.6 kBd ... 12 MBd	
Baud rate	96	
Number of fieldbus nodes on master (max.)	none	
Visualization	WAGO-I/O-PRO V2.3 (based on CODESYS V2.3)	
Programming environment	CODESYS V2: 128 KB / 64 KB / 8 KB	
Program memory/data memory/non-volatile memory (software)	63	
Number of modules per node (max.)	244 bytes/244 bytes	
Input and output process image (fieldbus) max.	244 bytes	
Memory for fieldbus input variables (max.)	244 bytes	
Memory for fieldbus output variables (max.)	24 VDC (-25 ... +30 %); via pluggable connector (CAGE CLAMP® connection)	
Supply voltage (system)	24 VDC (-25 ... +30 %); via power jumper contacts	
Supply voltage (field)	500 mA	
Input current (typ.) at nominal load (24 V)	200 mA	
Current consumption (5 V system supply)	1800 mA	
Total current (system supply)	0 ... +55 °C	
Ambient temperature (operation)	-20 ... +60 °C	
Dimensions W x H x D	(50.5 x 100 x 71.1) mm	
Approvals	CE; Marine; OrdLoc/HazLoc; ATEX/IECEX	

For data sheet and additional information, see:

wago.com/750-833

Controller 750 ▶ DeviceNet



750-806

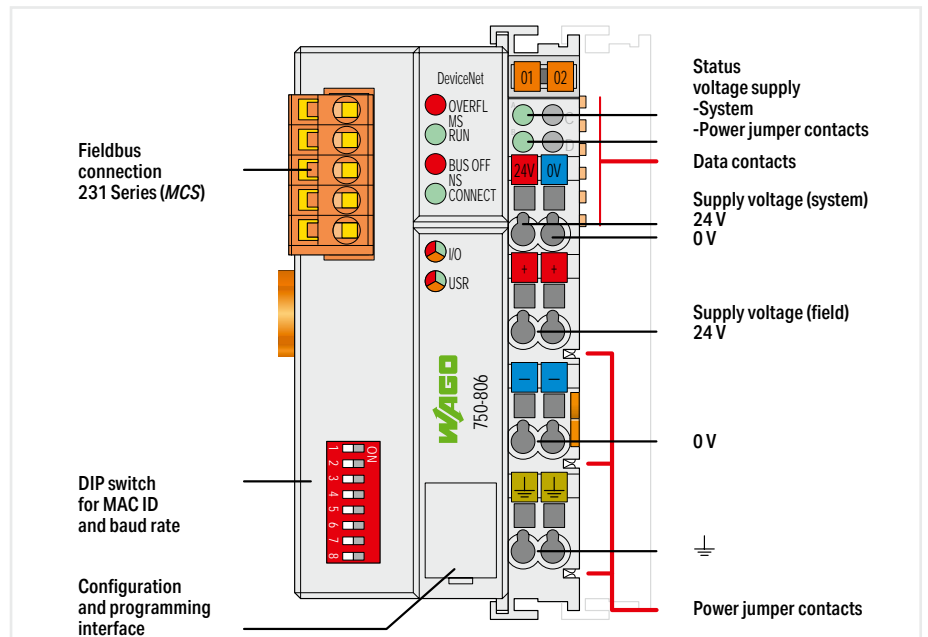

Version	Standard
Item no.	750-806
Order Text	Controller DeviceNet
Technical data	
Communication	DeviceNet
Connection technology: communication/fieldbus	DeviceNet: 1 x Male connector; 5-pole
Bus segment length (max.)	500 m
Baud rate	500 kBd (125 kBd, 250 kBd, 500 kBd)
Number of fieldbus nodes on master (max.)	64
Visualization	none
Programming environment	WAGO-I/O-PRO V2.3 (based on CODESYS V2.3)
Program memory/data memory/non-volatile memory (software)	CODESYS V2: 128 KB / 64 KB / 8 KB
Number of modules per node (max.)	64
Input and output process image (fieldbus) max.	1024 bytes/1024 bytes
Memory for fieldbus input variables (max.)	512 bytes
Memory for fieldbus output variables (max.)	512 bytes
Supply voltage (system)	24 VDC (-25 ... +30 %); via pluggable connector (CAGE CLAMP® connection)
Supply voltage (field)	24 VDC (-25 ... +30 %); via power jumper contacts
Input current (typ.) at nominal load (24 V)	500 mA
Current consumption (5 V system supply)	350 mA
Input current via DeviceNet interface at 11 V	120 mA
Total current (system supply)	1650 mA
Ambient temperature (operation)	0 ... +55 °C
Dimensions W x H x D	(50.5 x 100 x 71.1) mm
Approvals	CE; Marine; OrdLoc/HazLoc; ATEX/IECEx
For data sheet and additional information, see:	wago.com/750-806

Controller 750 ► CANopen; MCS



750-837

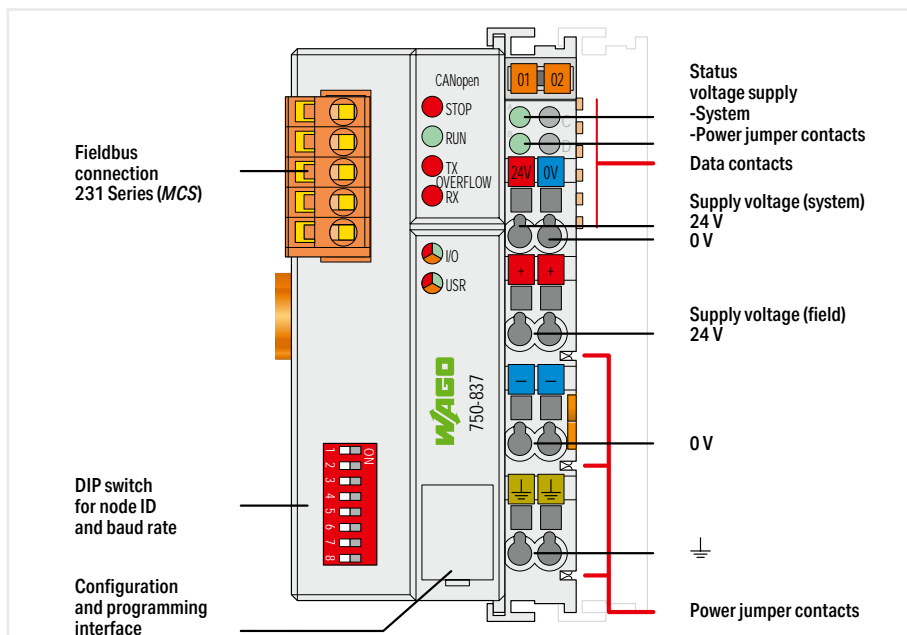

Version	Standard	640/832 KB program/RAM
Item no.	750-837	750-837/021-000
Order Text	Controller CANopen; M1; MCS	Controller CANopen; M3; MCS

Technical data		
Communication	CANopen	
Connection technology: communication/fieldbus	CANopen: 1 x Male connector; 5-pole	
Bus segment length (max.)	1000 m	
Baud rate	10 kBd ... 1 MBd	
Number of fieldbus nodes on master (max.)	110	
Visualization	none	
Programming environment	WAGO-I/O-PRO V2.3 (based on CODESYS V2.3)	
Program memory/data memory/non-volatile memory (software)	CODESYS V2: 128 KB / 64 KB / 8 KB	CODESYS V2: 640 KB / 832 KB / 8 KB
Number of modules per node (max.)	64	
Input and output process image (fieldbus) max.	512 bytes/512 bytes	
Memory for fieldbus input variables (max.)	512 bytes	
Memory for fieldbus output variables (max.)	512 bytes	
Communication profile	DS-301 V4.01	
Device profile	DS-401 V2.0; Limit value monitoring; Edge-triggered PDOs; Configurable response in the event of an error; DSP 405; NMT master can be programmed using function blocks	
Number of PDOs	32 Tx / 32 Rx	
Number of SDOs	2 SDO servers / 16 SDO clients	
Supply voltage (system)	24 VDC (-25 ... +30 %); via pluggable connector (CAGE CLAMP® connection)	
Supply voltage (field)	24 VDC (-25 ... +30 %); via power jumper contacts	
Input current (typ.) at nominal load (24 V)	500 mA	
Current consumption (5 V system supply)	350 mA	
Total current (system supply)	1650 mA	
Ambient temperature (operation)	0 ... +55 °C	
Dimensions W x H x D	(50.5 x 100 x 71.1) mm	
Approvals	CE; Marine; OrdLoc/HazLoc; ATEX/IECEX	
For data sheet and additional information, see:	wago.com/750-837	

Controller 750 ▶ CANopen; D-Sub

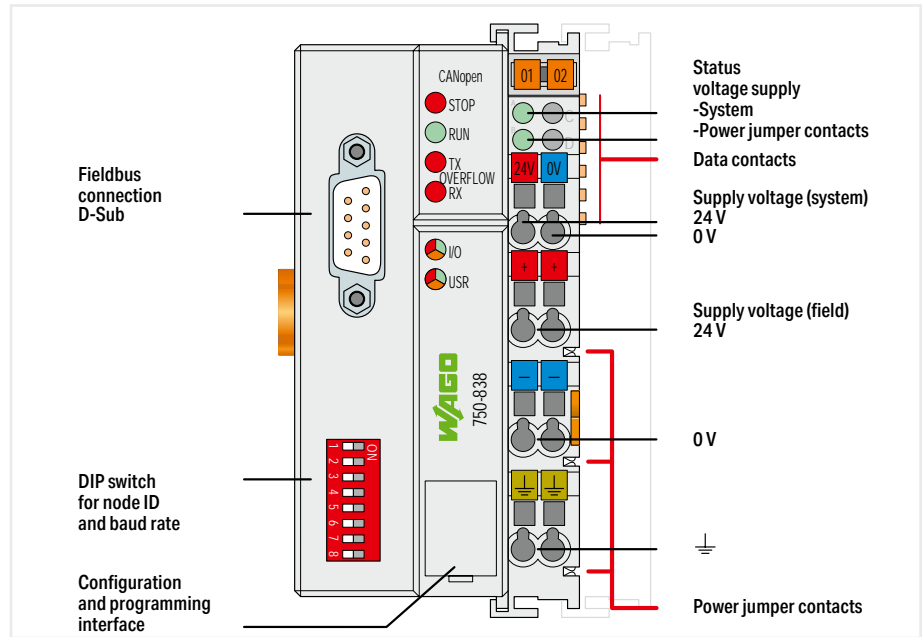

750-838

Version	Standard	640/832 KB program/RAM
Item no.	750-838	750-838/021-000
Order Text	Controller CANopen; M1; DSub	Controller CANopen; M3; DSub

Technical data		
Communication	CANopen	
Connection technology: communication/fieldbus	CANopen: 1 x D-sub 9 plug	
Bus segment length (max.)	1000 m	
Baud rate	10 kBd ... 1 MBd	
Number of fieldbus nodes on master (max.)	110	
Visualization	none	
Programming environment	WAGO-I/O-PRO V2.3 (based on CODESYS V2.3)	
Program memory/data memory/non-volatile memory (software)	CODESYS V2: 128 KB / 64 KB / 8 KB	CODESYS V2: 640 KB / 832 KB / 8 KB
Number of modules per node (max.)	64	
Input and output process image (fieldbus) max.	512 bytes/512 bytes	
Memory for fieldbus input variables (max.)	512 bytes	
Memory for fieldbus output variables (max.)	512 bytes	
Communication profile	DS-301 V4.01	
Device profile	DS-401 V2.0; Limit value monitoring; Edge-triggered PDOs; Configurable response in the event of an error; DSP 405; NMT master can be programmed using function blocks	
Number of PDOs	32 Tx / 32 Rx	
Number of SDOs	2 SDO servers / 16 SDO clients	
Supply voltage (system)	24 VDC (-25 ... +30 %); via pluggable connector (CAGE CLAMP® connection)	
Supply voltage (field)	24 VDC (-25 ... +30 %); via power jumper contacts	
Input current (typ.) at nominal load (24 V)	500 mA	
Current consumption (5 V system supply)	350 mA	
Total current (system supply)	1650 mA	
Ambient temperature (operation)	0 ... +55 °C	
Dimensions W x H x D	(50.5 x 100 x 71.1) mm	
Approvals		
For data sheet and additional information, see:	wago.com/750-838	



Controllers 750 XTR

Controllers PFC100/PFC200

- Maximum performance in a minimum space
- Also programmable in high-level languages based on Linux®
- Security packages with SSH and SSL/TLS
- Runtime system for CODESYS V3

◀◀◀ Section 6.1

Controllers PFC200 XTR

- The advantages of WAGO's PFC Controllers combined with the capabilities for extreme environments:
- High processing speed
- Multiple interfaces
- eXTRemely robust and maintenance-free

◀◀◀ Section 6.2

Basic Controllers 100

- Freely programmable per IEC 61131-3 with CODESYS V3
- HTML-5-based Web visualization
- Syslog in compliance with RFC 5424 and role-based user management (RBAC)
- Large amount of memory for projects and data

◀◀ Section 6.3

Controllers 750

- Controllers for all common fieldbus systems
- Programmable per IEC 61131-3
- Readily combines with the modules of the WAGO I/O System 750

◀ Section 6.4

Controllers 750 XTR

- For demanding applications in which the following are critical:
- Extreme temperature resistance
- Immunity to electromagnetic interference and impulse voltages
- Vibration and shock resistance

Starter Kits

For the entry into the most diverse application possibilities

IoT Boxes

Integrating machines and plants into the Internet of Things

Section 6.6 ▶

Controllers 750 XTR

Contents

	Page
General Product Information	174
Interfaces and Types	175
Item Number Key	175
Standards and Rated Conditions for Railway Applications (EN 50155)	175
Installation Instructions	176
Standards and Rated Conditions	177
Approvals	177



CPU	ETHERNET		Description	Item No.	
	Modbus (TCP, UDP)	CANopen			
32 bits	M/S		Controller Modbus TCP; 4th Generation; 2 x ETHERNET, SD Card Slot; Extreme	750-890/040-000	178
32 bits		M/S	Controller CANopen; 640/832 KB Program/RAM; D-Sub; Extreme	750-838/040-000	179

M: Master, S: Slave

Controllers 750 XTR

General Product Information

6.5

Controllers 750 XTR: Taking It to the eXTReme – The Standard for 750 XTR

With the dark gray XTR version of the Controllers 750, you will benefit from the unique added value of this system for applications that are subjected to extreme environments.

Extremely temperature-resistant, immune to interference, as well as unfazed by vibrations and impulse voltages – the WAGO I/O System 750 XTR is the first choice for demanding applications including:

- Marine systems and onshore/offshore installations
- Renewable energy systems (wind turbines, solar systems and biogas plants)
- Transformer stations and power distribution systems
- Petrochemical processing
- Water and wastewater treatment systems
- Custom machines
- Railway systems

Marine and Onshore/Offshore Industries

International approvals coupled with industry-specific features permit use in marine applications and other harsh sectors. Addressing requirements inherent in specific industries and operating environments has enabled use on marine diesels and in the EMC-sensitive area of a vessel's bridge. Because the requirements are significantly greater for both interference immunity and emission, along with superior mechanical performance in these sensitive areas, the WAGO I/O System will readily meet the needs of other industries.

Telecontrol Technology

Standardized IEC 60870-5, IEC 61850, IEC 61400-25 and DNP3 Telecontrol Protocols allow the Controllers 750 XTR to be used in telecontrol applications. These controllers also meet stricter requirements for immunity to impulse voltages according to EN 60870-2-1.

The result is a tailor-made solution for demanding telecontrol applications that readily meets all requirements.

Link between Process Data and IT Application – Even under eXTReme Conditions

WAGO's controllers ideally combine real-time requirements with IT functionality. They support Modbus/TCP and EtherNet/IP for use in industrial environments. HTTP, SNMP, FTP, BootP, DHCP, DNS and other protocols simplify integration into IT environments. Integrated Web pages and Web-based visualization provide IT applications with real-time process data. Furthermore, the controllers incorporate library functions for email, SOAP, ASP, IP configuration, ETHERNET sockets and file system.

Modular and Expandable

With the WAGO I/O System 750 XTR, the Controllers 750 XTR can be expanded to almost any input/output interface. Using an industry-leading platform, the 750 XTR boasts the same proven benefits.

Worldwide Approvals

International approvals for industrial automation, building technology, shipbuilding and onshore/offshore applications guarantee worldwide use – even under harsh operating conditions, e.g., Germanischer Lloyd, Det Norske Veritas, American Bureau of Shipping, Korean Register of Shipping, Nippon Kaiji Kyokai, Registro Italiano Navale and Polski Rejestr Stratkow.

Superior Reliability in Extreme Climates

Engineered for freezing cold, extreme heat and high humidity, the WAGO I/O System 750 XTR provides absolute dependability in virtually any weather. The XTR version of the Controllers 750 is unfazed by both freezing cold down to -40°C and scorching heat up to +70°C. And this applies equally for both start-up and ongoing operation. The maximum approved operating altitude of 5,000 m is another highlight. Even in the thin air of a mountain-top station, the system impressively demonstrates its high performance and availability.

Additional Protection against Interference Pulses

The WAGO I/O System 750 XTR provides greater immunity to impulse voltages up to 5 kV, lower EMC emission of interference and higher insensitivity to EMC interference. These strengths ensure trouble-free operation.

High Mechanical Performance

Automation systems must be incredibly vibration-resistant, especially when installed close to vibration-prone and shock-generating system components. Powerful motors and power circuit breakers are just two examples of the many applications that can stress automation systems. The WAGO I/O System 750 XTR continues to set new standards here. Count on long-lasting, trouble-free operation and industry-topping levels of safety – even in the most severe applications, such as tunnel boring machines.



Benefits:

- Controllers for eXTReme environmental conditions
 - No air conditioning required
 - Can be used in unshielded areas
 - Install close to vibrating and shock-generating system components
- Extensive IT integration possibilities
- Expandable with the WAGO I/O System 750 XTR's comprehensive product range
- Maintenance-free
- Vibration-proof, fast and maintenance-free CAGE CLAMP® spring connections

Controllers 750 XTR Interfaces and Types

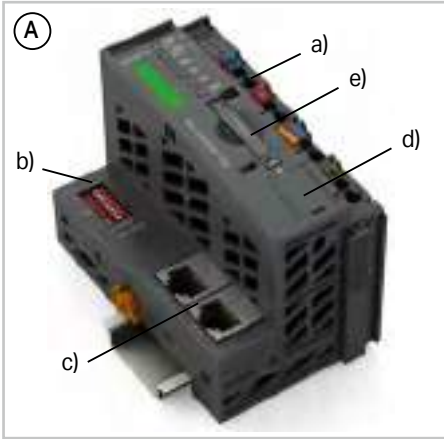

- Includes a supply module (a) to power downstream I/O modules
- Technical differences on the connection level; addressing switch (b) and fieldbus interface (c)
- Service interface (d)

Housing Design (A)

- SD card slot for external storage media (e)
- W x H x D (mm): 61.5 x 100 x 71.9

Housing Design (B)

- W x H x D (mm): 50.5 x 100 x 71.1

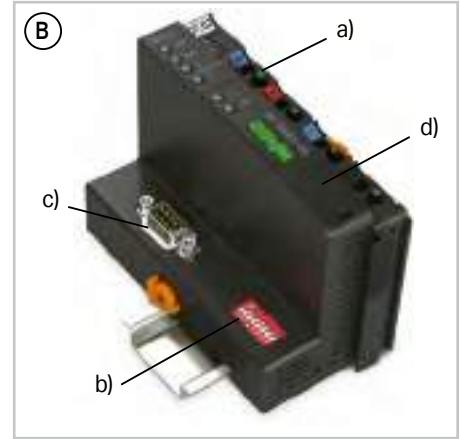

Item Number Key

Explanation of an item number key's components

Item No. : 750-8xx/040-00y	
3x: 16 bits	CANopen
8x, 9x: 32-bit multitasking 001:	ETHERNET Telecontrol Technology

Standards and Rated Conditions for Rail Applications (EN 50155)

Railway Applications (EN 50155)	Class/Standard Compliance
4.1 Rated operating conditions	
4.1.1 Altitude above sea level	AX (EN 50125-1)
4.1.2 Surrounding air temperature	TX
4.1.3 Shock and vibration	1A and 1B (EN 61373)
4.1.4 Relative humidity	95 % (coated PCBs)
5.1 Power supply	
5.1.1.1 Voltage fluctuations	
Minimum voltage	0.725 x Un
Maximum voltage	1.3 x Un
5.1.1.2 Power interruptions	S1
5.4 Surge, ESD, burst tests	EN 50121-3-2
5.5 EMC (emission of interference, immunity to interference)	EN 50121-3-2, EN 50121-4, -5
Fire behavior: per EN 45545-2 hazard level HL3	

WAGO is certified in accordance with the IRIS quality standard.

Controllers 750 XTR Installation Instructions

Power Supply

6.5

The internal electronics are powered by the controller. The power supply to the field-side supply is electrically isolated. This division enables a separate supply for sensors and actuators. Snapping the I/O modules together automatically routes the supply voltages. Supply modules with diagnostics also enable power supply monitoring. This ensures a flexible and customized supply configuration for a fieldbus node.

Power supply to the electronics is limited by a maximum value. This value is dependent on the controller used. If the sum of the internal current demand of all the I/O modules should exceed this value, an additional system supply module is necessary. Furthermore, the current consumed for field-side supply must not exceed 10 A. A variety of power supply modules allows re-feeding, creating potential groups and implementing emergency stops.

Interference-Free in Safety-Related Applications

To easily and safely perform a cost-effective and centralized deactivation of complete actuator groups, the actuator's power supply can be switched off using a safety switching device. This can either be performed for each individual actuator or by turning off the power supply to a group of control outputs.

In the event of failure, ensure that no interference from other current or power circuits occurs – even when the control voltage is switched off – so the defined safety function properties (logic and time response) remain unchanged.

All 750 XTR Series Digital Output Modules are designed to provide interference-free safety functionality. The modules can be used in safety applications up to category 4 per DIN EN ISO 13849-1:2007. Safety category and performance level depend solely on the safety components and their wiring.

Notice:

WAGO's interference-free I/O modules have no active influence on the safety function, they are not an active part of the safety application and are not a substitute for the safety switching device! When using the components in safety functions, the corresponding notes must be observed in the relevant manual.

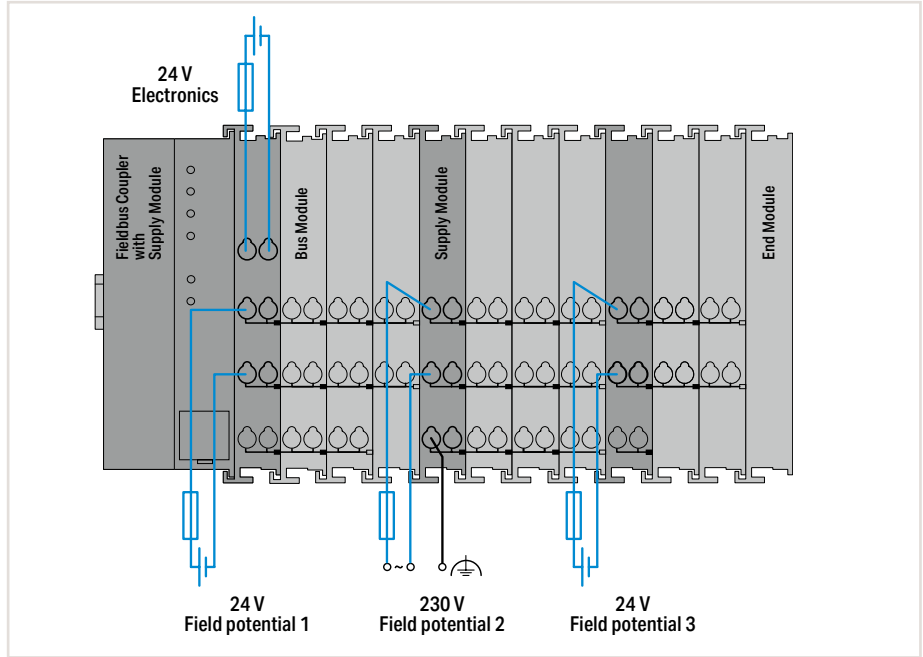

Notes:

Additional steps must be implemented based on where the I/O system is installed:

Specific power and field-side power supply filters (750-624/040-001 or 750-626/040-000) are required for marine and onshore/offshore applications, as well as in telecontrol and rail technology.

Please refer to the manual for details about the power supply's design.

Mixed Operation

Mixed operation (standard/XTR modules) within a node is possible when groups of modules are electrically isolated on the field side (i.e., electrically isolated power supply). This combination may be useful, for example, when there are only increased requirements for immunity to impulse voltages and interference, but the surrounding air temperature is not critical.

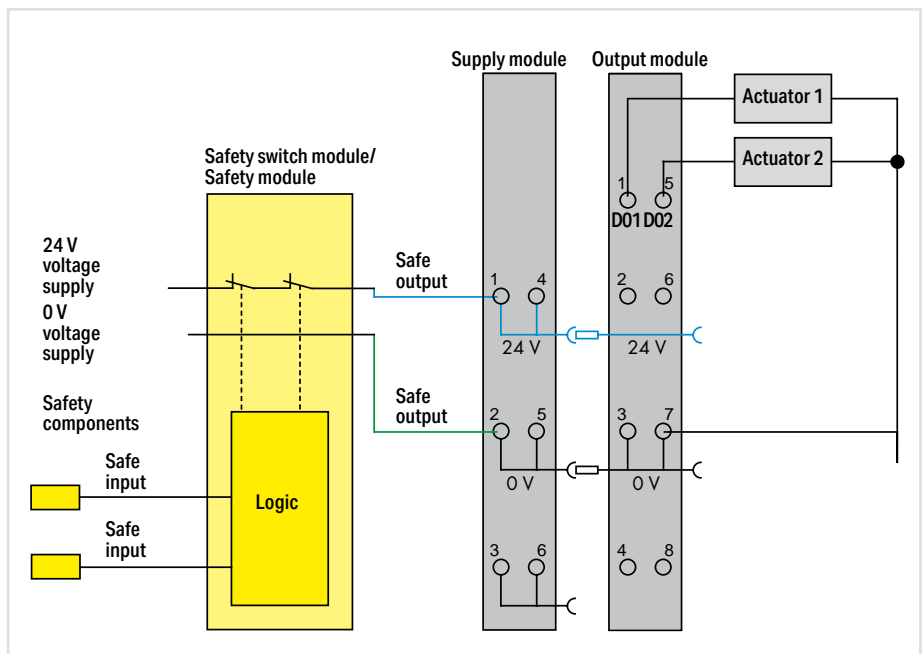

Controller 750 XTR

Standards and Rated Conditions

General technical data	
Supply voltage (system)	24 VDC; via pluggable connector (CAGE CLAMP® connection); Derating must be observed!
Ambient temperature (operation)	-40 ... +70 °C
Surrounding air temperature (storage)	-40 ... +85 °C
Relative humidity (without condensation)	95 %
Relative humidity (with condensation)	Short-term condensation per Class 3K7/IEC EN 60721-3-3 and E-DIN 40046-721-3 (except for wind-driven precipitation, water and ice formation)
Operating altitude	without temperature derating: 0 ... 2000 m; with temperature derating: 2000 ... 5000 m (0.5 K/100 m); 5000 m (max.)
Pollution degree	2 per IEC 61131-2
Vibration resistance	per IEC 60068-2-6 (acceleration: 5g), EN 60870-2-2, IEC 60721-3-1, -3, EN 50155; EN 61373
Shock resistance	per IEC 60068-2-27 (15g/11 ms/half-sine/1,000 shocks; 25g/6 ms/1,000 shocks), EN 50155, EN 61373
EMC emission of interference	per EN 61000-6-3, -4, EN 61131-2, EN 60255-26, marine applications, EN 60870-2-1, EN 61850-3, EN 50121-3-2, EN 50121-4, -5
Protection type	IP20
Mounting position	horizontal (standing/lying); vertical
Mounting type	DIN-35 rail
Housing material	Polycarbonate; polyamide 6.6
Exposure to pollutants	per IEC 60068-2-42 and IEC 60068-2-43
Permissible SO ₂ contaminant concentration at a relative humidity 75 %	25 ppm
Permissible H ₂ S contaminant concentration at a relative humidity 75 %	10 ppm
Connection technology: system supply	2 x CAGE CLAMP®
Connection technology: field supply	4 x CAGE CLAMP®
Solid conductor	0.25 ... 2.5 mm ² / 24 ... 14 AWG
Fine-stranded conductor	0.25 ... 2.5 mm ² / 24 ... 14 AWG
Strip length	8 ... 9 mm / 0.31 ... 0.35 inches
Current carrying capacity (power jumper contacts)	10 A

Approvals

For approvals overview (item comparison), see Section 14 (Technical Section) or visit www.wago.com.



Cables and connectors	Page 680
Communication	Page 678
DIN-rail	Page 716
Marking	Page 714
Shield termination	Page 708
Software	Page 36
System enclosure	Page 693

Controller 750 XTR ▶ Modbus TCP; SD card slot

6.5



750-890/040-000

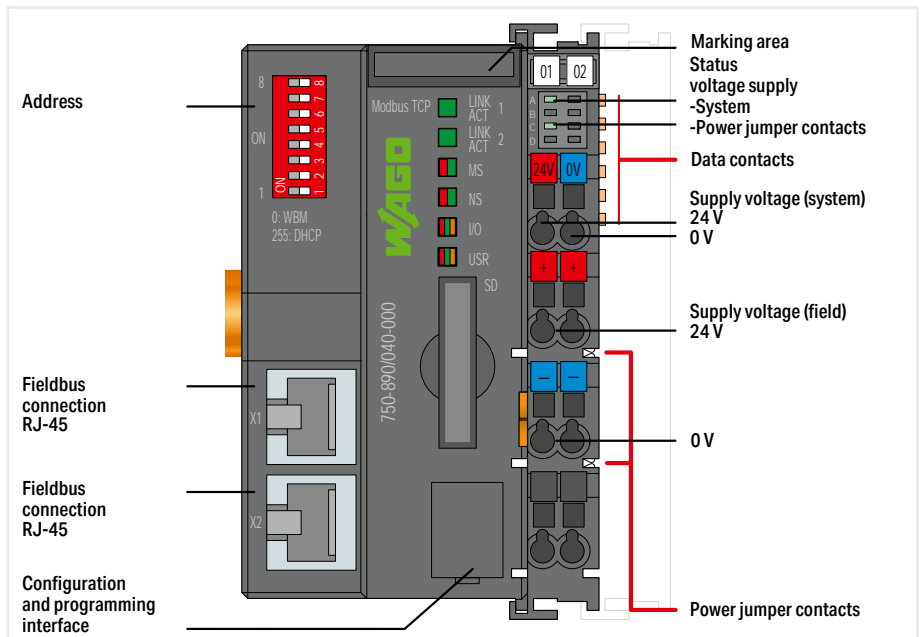

Version	extreme
Item no.	750-890/040-000
Order Text	Controller Modbus TCP; G4; SD; XTR

Technical data	
Communication	Modbus (TCP, UDP)
ETHERNET protocols	HTTP(S); BootP; DHCP; DNS; SNMP; FTP(S); SNMP
Connection technology: communication/fieldbus	Modbus (TCP, UDP); 2 x RJ-45
Baud rate	10/100 Mbit/s
Visualization	Web-Visu
Programming environment	WAGO-I/O-PRO V2.3 (based on CODESYS V2.3)
Type of memory card	SD and SDHC up to 32 GB (all guaranteed properties only valid with WAGO Memory Card)
Program memory/data memory/non-volatile memory (software)	CODESYS V2: 8 MB / 8 MB / 32 KB
Number of modules per node (max.)	64
Input and output process image (fieldbus) max.	1020 words/1020 words
Supply voltage (system)	24 VDC; via pluggable connector (CAGE CLAMP® connection); Derating must be observed!
Supply voltage (field)	24 VDC; Power supply via pluggable connector (CAGE CLAMP® connection); Transmission via power jumper contacts; Derating must be observed!
Derating	Derating (supply voltage): Ambient temperatures under laboratory conditions: (-25 ... +30 %); for -40 ... +55 °C: 24 V (-25 ... +20 %); for +55 ... +70 °C: 24 V (-25 ... +10 %); Lower limit in all temperature ranges: -27.5 % (including 15 % residual ripple)
Input current (typ.) at nominal load (24 V)	500 mA
Current consumption (5 V system supply)	440 mA
Total current (system supply)	1700 mA
Ambient temperature (operation)	-40 ... +70 °C
Dimensions W x H x D	(61.5 x 100 x 71.9) mm
Approvals	CE; Marine; OrdLoc/HazLoc; ATEX/IECEx
For data sheet and additional information, see:	wago.com/750-890/040-000
Accessories	
Memory Card SD; SLC-NAND; 2 GByte; Temperature from -40 to 90 °C	758-879/000-001
Memory Card SD; pSLC-NAND; 8 GB; Temperature range: -40 to 90 °C	758-879/000-2108

Version	extreme
Item no.	750-890/040-000
Order Text	Controller Modbus TCP; G4; SD; XTR
Technical data	
Communication	Modbus (TCP, UDP)
ETHERNET protocols	HTTP(S); BootP; DHCP; DNS; SNMP; FTP(S); SNMP
Connection technology: communication/fieldbus	Modbus (TCP, UDP); 2 x RJ-45
Baud rate	10/100 Mbit/s
Visualization	Web-Visu
Programming environment	WAGO-I/O-PRO V2.3 (based on CODESYS V2.3)
Type of memory card	SD and SDHC up to 32 GB (all guaranteed properties only valid with WAGO Memory Card)
Program memory/data memory/non-volatile memory (software)	CODESYS V2: 8 MB / 8 MB / 32 KB
Number of modules per node (max.)	64
Input and output process image (fieldbus) max.	1020 words/1020 words
Supply voltage (system)	24 VDC; via pluggable connector (CAGE CLAMP® connection); Derating must be observed!
Supply voltage (field)	24 VDC; Power supply via pluggable connector (CAGE CLAMP® connection); Transmission via power jumper contacts; Derating must be observed!
Derating	Derating (supply voltage): Ambient temperatures under laboratory conditions: (-25 ... +30 %); for -40 ... +55 °C: 24 V (-25 ... +20 %); for +55 ... +70 °C: 24 V (-25 ... +10 %); Lower limit in all temperature ranges: -27.5 % (including 15 % residual ripple)
Input current (typ.) at nominal load (24 V)	500 mA
Current consumption (5 V system supply)	440 mA
Total current (system supply)	1700 mA
Ambient temperature (operation)	-40 ... +70 °C
Dimensions W x H x D	(61.5 x 100 x 71.9) mm
Approvals	CE; Marine; OrdLoc/HazLoc; ATEX/IECEx
For data sheet and additional information, see:	wago.com/750-890/040-000
Accessories	
Memory Card SD; SLC-NAND; 2 GByte; Temperature from -40 to 90 °C	758-879/000-001
Memory Card SD; pSLC-NAND; 8 GB; Temperature range: -40 to 90 °C	758-879/000-2108

Controller 750 XTR ▶ CANopen; D-Sub



750-838/040-000

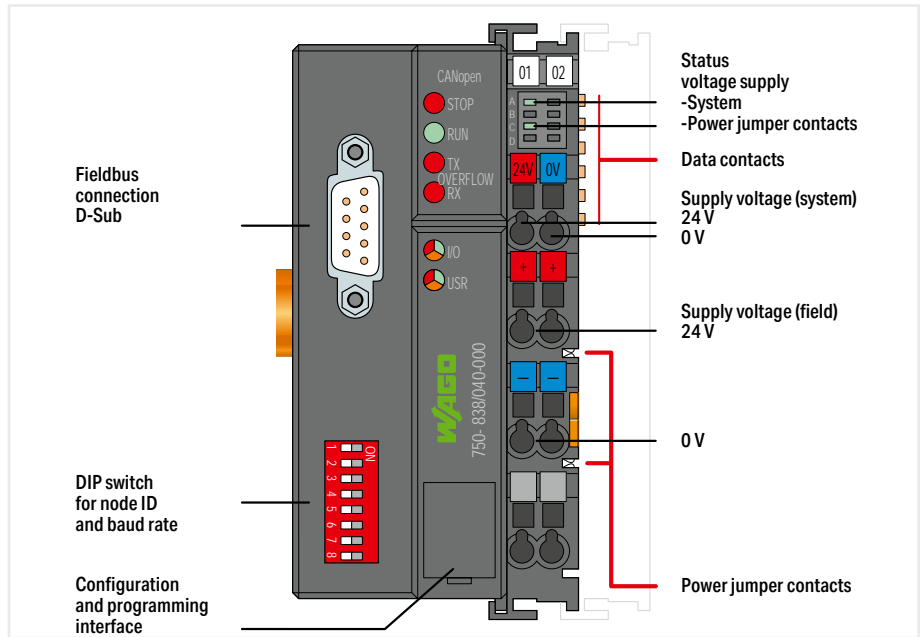

Version	extreme
Item no.	750-838/040-000
Order Text	Controller CANopen; M3; DSub; XTR
Technical data	
Communication	CANopen
Connection technology: communication/fieldbus	CANopen: 1 x D-sub 9 plug
Bus segment length (max.)	1000 m
Baud rate	10 kBd ... 1 Mbd
Number of fieldbus nodes on master (max.)	110
Visualization	none
Programming environment	WAGO-I/O-PRO V2.3 (based on CODESYS V2.3)
Program memory/data memory/non-volatile memory (software)	CODESYS V2: 640 KB / 832 KB / 8 KB
Number of modules per node (max.)	64
Input and output process image (fieldbus) max.	512 bytes/512 bytes
Memory for fieldbus input variables (max.)	512 bytes
Memory for fieldbus output variables (max.)	512 bytes
Communication profile	DS-301 V4.01
Device profile	DS-401 V2.0; Limit value monitoring; Edge-triggered PDOs; Configurable response in the event of an error; DSP 405; NMT master can be programmed using function blocks
Number of PDOs	32 Tx / 32 Rx
Number of SDOs	2 SDO servers / 16 SDO clients
Supply voltage (system)	24 VDC; via pluggable connector (CAGE CLAMP® connection); Derating must be observed!
Supply voltage (field)	24 VDC; Power supply via pluggable connector (CAGE CLAMP® connection); Transmission via power jumper contacts; Derating must be observed!
Derating	Total current for system supply: 1650 mA (ambient (operating) temperature < 60 °C; 1250 mA (ambient (operating) temperature: 60 ... 70 °C); Derating (supply voltage): Ambient temperatures under laboratory conditions: (-25 ... +30 %); for -40 ... +55 °C: 24 V (-25 ... +20 %); for +55 ... +70 °C: 24 V (-25 ... +10 %); Lower limit in all temperature ranges: -27.5 % (including 15 % residual ripple)
Input current (typ.) at nominal load (24 V)	500 mA
Current consumption (5 V system supply)	350 mA
Total current (system supply)	1650 mA
Ambient temperature (operation)	-40 ... +70 °C
Dimensions W x H x D	(50.5 x 100 x 71.1) mm
Approvals	CE; Marine; OrdLoc/HazLoc; ATEX/IECEX
For data sheet and additional information, see:	wago.com/750-838/040-000



Starter Kits and IoT Boxes

Controllers PFC100/PFC200

- Maximum performance in a minimum space
- Also programmable in high-level languages based on Linux®
- Security packages with SSH and SSL/TLS
- Runtime system for CODESYS V3

◀◀◀◀ Section 6.1

Controllers PFC200 XTR

- The advantages of WAGO's PFC Controllers combined with the capabilities for extreme environments:
- High processing speed
- Multiple interfaces
- eXTRemely robust and maintenance-free

◀◀◀◀ Section 6.2

Basic Controllers 100

- Freely programmable per IEC 61131-3 with CODESYS V3
- HTML-5-based Web visualization
- Syslog in compliance with RFC 5424 and role-based user management (RBAC)
- Large amount of memory for projects and data

◀◀◀ Section 6.3

Controllers 750

- Controllers for all common fieldbus systems
- Programmable per IEC 61131-3
- Readily combines with the modules of the WAGO I/O System 750

◀◀ Section 6.4

Controllers 750 XTR

- For demanding applications in which the following are critical:
- Extreme temperature resistance
- Immunity to electromagnetic interference and impulse voltages
- Vibration and shock resistance

◀ Section 6.5

Starter Kits

For the entry into the most diverse application possibilities

IoT Boxes

Integrating machines and plants into the Internet of Things

WAGO Starter Kits and IoT Boxes Contents

Page



Modbus (TCP, UDP)	EtherNet/IP™	EtherCAT	KNX IP	CANopen	Modbus RTU	IoT Protocols	Description	Item No.	
M/S	S					x	Starter Kit; e!COCKPIT with Controller PFC100; 2 x ETHERNET; Eco	8003-099/750-8100	182
M/S	M/S	M			x	x	Starter Kit; Linux® with Controller PFC200; 2nd Generation; 2 x ETHERNET, RS-232/-485	8003-099/750-8212	183
M/S	M/S	M		M/S	x	x	Starter Kit; Touch Panel 600, Advanced Line, Control Panel	8003-099/762-5303	184
M/S			x				Starter Kit; KNX IP with Controller KNX IP	8003-001/K999-9999/000-901	185
M/S	M/S	M			x	x	WAGO IoT-Box; Energy Data with Controller PFC200 (750-8212)	2854-099/000-001	186
M/S	M/S	M			x	x	WAGO IoT-Box; MES with Controller PFC200 (750-8212)	2854-099/000-002	187
M/S	S	M*			x	x	WAGO IoT-Box; Energy Data 4G with Controller PFC200 (750-8217)	2854-099/000-003	188
M/S	S	M*			x	x	WAGO IoT-Box; MES 4G with Controller PFC200 (750-8217)	2854-099/000-004	189

M: Master, S: Slave; *requires an additional license

6.6
Starter Kits
and IoT Boxes

Starter Kit; e!COCKPIT with Controller PFC100; 2 x ETHERNET; Eco

6.6

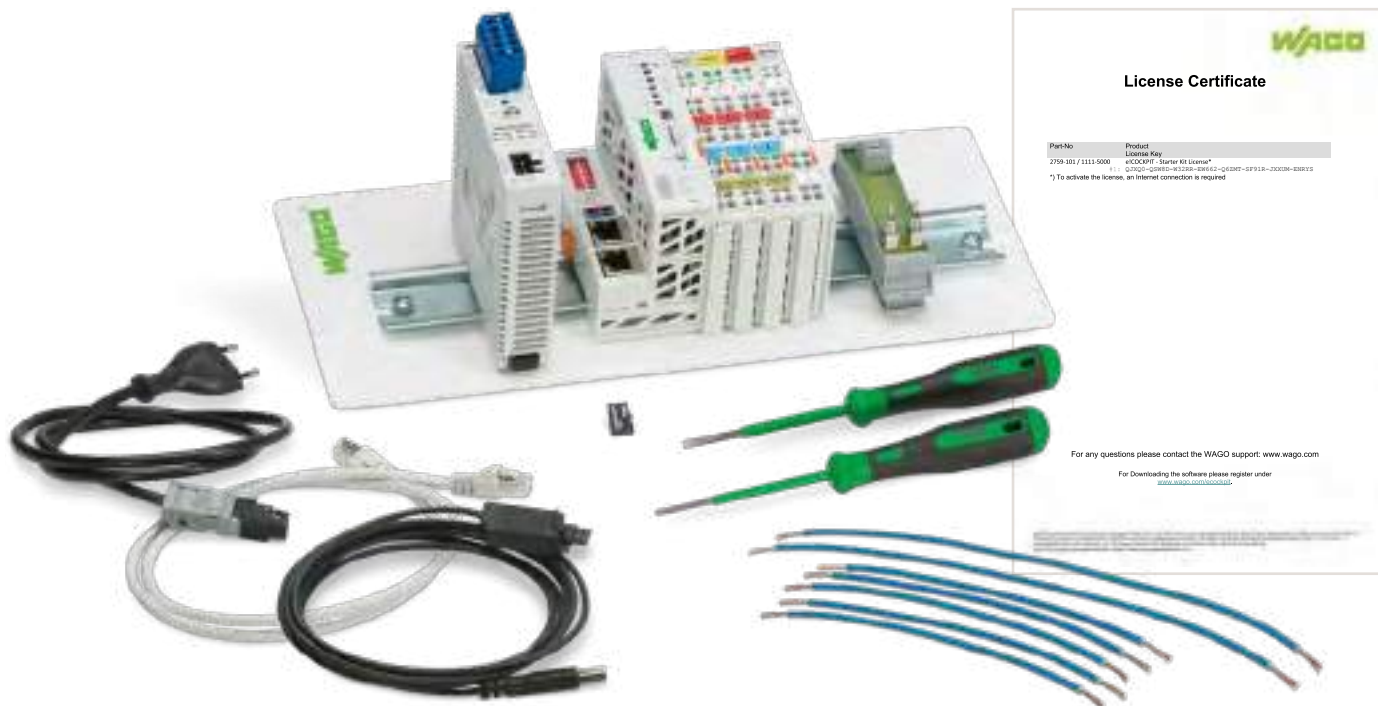

The PFC100 Controller can be seamlessly integrated into WAGO's e!COCKPIT Engineering Software, which can be used for hardware configuration, programming, simulation and visualization of complex control tasks.

Tightly integrated automation software and controller hardware provide the ideal platform for advanced and intuitive CODESYS V3-based engineering.

Item Description	Item No.
Starter Kit; e!COCKPIT	8003-099/750-8100
The WAGO Starter Kit e!COCKPIT includes:	
Controller PFC100; 2 x ETHERNET; Eco	750-8100
Supply Module; 24 VDC	750-602
2-Channel Digital Input; 24 VDC; 3 ms	750-400
2-Channel Digital Output; 24 VDC; 0.5 A	750-501
End Module	750-600
Power Supply Classic; 24 VDC output voltage; 1 A	787-1602
Switching Module; 2-way DI simulator	288-863
Development Environment e!COCKPIT; Licence for 1 PC	2759-0101/1111-5000
USB Communication Cable; 2.5 m	750-923
Memory Card microSD; 2 GB	758-879/000-3102
Operating Tool; Type 1; (3.5 x 0.5) mm blade	210-720
Operating Tool; Type 1; (2.5 x 0.4) mm blade	210-719
Patch Cable; 1.0 m	

Starter Kit; Linux® with Controller PFC200; 2nd Generation; 2 x ETHERNET, RS-232/-485



With the PFC200 Controller as its central component, the Linux® Starter Kit provides an entry to the world of open programming. In addition to its scalability through the open-source community, the primary advantage of having a controller with an open-source operating system is that it is continually developed and maintained.

Besides the PFC200, other components of the starter kit include input and output modules, a power supply, a switching module and the accessories needed to start programming immediately with Linux®.

Additional information on Linux® is available at:
wago.com/linux

Item Description	Item No.
Starter Kit; Linux®	8003-099/750-8212

The WAGO Starter Kit Linux® includes:

Controller PFC200; 2nd Generation; 2 x ETHERNET, RS-232/-485	750-8212
2-Channel Digital Input; 24 VDC; 3 ms	750-400
2-Channel Digital Output; 24 VDC; 0.5 A	750-501
End Module	750-600
Power Supply Classic; 24 VDC output voltage; 1 A	787-1602
Switching Module; 2-way DI simulator	288-863
Operating Tool; Type 1; (3.5 x 0.5) mm blade	210-720
Operating Tool; Type 1; (2.5 x 0.4) mm blade	210-719
Patch Cable; 1.0 m	

Starter Kit; Touch Panel 600, Advanced Line, Control Panel

6.6



The WAGO Starter Kit Touch Panel 600 contains an Advanced Control Panel 17.8 cm (7.0") with a full single-user license of the *e!COCKPIT* Engineering Software (based on CODESYS V3). Required accessories for power supply, assembly and installation of the panel are included for easy commissioning.

Demo applications, which illustrate the extensive possibilities of visualization, web connectivity and programming with *e!COCKPIT*, can be started directly from the SD card.

Additionally, a Docker® application demonstrates another option for creating applications under Linux® via open-source software.

After a successful start, both the open operating system and the full version of the engineering software are available for the free creation of applications. WAGO's Touch Panel has 2 x LAN, 1 x RS, 1 x CAN, DI/O interfaces and supports communication protocols such as Modbus/UDP/TCP/RTU, CANopen, CAN2.0, OPC UA, MQTT.

Additional protocols, such as BACnet/IP or EtherCAT® (Master), can be licensed optionally.

Item Description	Item No.
Starter Kit; Touch Panel 600, Advanced Line, Control Panel	8003-099/762-5303

The WAGO Starter Kit Touch Panel 600 includes:

Touch Panel 600; 17.8 cm (7.0"); 800 x 480 pixels; 2 x ETHERNET, 2 x USB, CAN, DI/DO, RS-232/485, Audio; Control Panel	762-5303/8000-002
Power Supply Classic; 24 VDC output voltage; 1 A	787-1602
Development Environment <i>e!COCKPIT</i> ; Licence for 1 PC	2759-0101/1111-5000
Memory Card microSD; pSLC-NAND; 8 GB	758-879/000-3108
Operating Tool; Type 1; (2.5 x 0.4) mm blade	210-719
Allen Wrench	
Cable; black/red; 2 x 0.5; 0.3 m	
Power Cable; 230 V	
Aluminum Feet; with groove	
Product Display; with cutout for 7" Touch Panel	
Mounting Accessories (Locking Clips, Mounting Brackets, M4x8 Screws)	
Patch Cable F/UTP; 1.0 m	

Starter Kit; KNX IP with Controller KNX IP



The WAGO Starter Kit KNX IP is available for those new to KNX IP. This starter kit is particularly well-suited to users seeking to:

- Expand existing KNX/EIB networks via the KNX/EIB/TP1 Interface to include the functionality of the modular WAGO I/O System and program applications themselves (IEC 61131-3)
- Have remote access to their KNX/EIB/TP1 network via the router
- Exploit the advantages of an ETHERNET network with KNX/EIB projects via the IP controller

Item Description	Item No.
Starter Kit; KNX IP	8003-001/K999-9999/000-901

The WAGO Starter Kit KNX IP includes:

Controller KNX IP	750-889
4-Channel Digital Input; 24 VDC; 3 ms	750-402
4-Channel Digital Output; 24 VDC; 0.5 A	750-504
End Module	750-600
KNX/EIB/TP1 Interface	753-646
Switched-Mode Power Supply; 24 VDC output voltage; 1.3 A	787-602
Development Environment, incl. USB Communication Cable; WAGO-I/O-PRO; USB Kit	759-333/000-923
Patch Cable; Cross-Over	

WAGO IoT Box; Energy Data with Controller PFC200 (750-8212)

6.6



Integrating machines and systems into the "Internet of Things" is incredibly quick and easy with the WAGO IoT Box Energy Data. This IoT Box features power and energy measurement functionality and is ready for immediate use. It also offers all the functions required for digitalization, from signal acquisition to cloud connectivity.

The IoT Box was designed as a plug-and-play device – no hardware engineering is needed. Collected data is transferred to the desired IoT application with just a few parameter settings.

The hardware includes a controller with its own communication interface, I/O modules with analog and digital inputs/outputs, a 3-phase power measurement module and a 24 V power supply unit.

Depending on the application, additional I/O modules can be added later to adapt the system to specific requirements.

Item Description	Item No.
IoT Box; Energy Data	2854-099/000-001
This IoT Box includes:	
Controller PFC200; 2nd generation; 2 x ETHERNET, RS-232/-485	750-8212
Switched-Mode Power Supply; Classic; 1-phase; Output voltage: 24 VDC; Output current: 2 A; NEC Class 2; DC OK signal	787-1606
8-Channel Digital Input; 24 VDC; 3 ms; 2-wire connection	750-1415
8-Channel Digital Output; 24 VDC; 0.5 A; 2-wire connection	750-1515
8-Channel Analog Input; Resistance measurement; Adjustable	750-451
4-Channel Analog Input; Voltage/current; Differential input; 16 bits; Diagnostics	750-471
3-Phase Power Measurement; 690 VAC 1 A	750-495
Rogowski Coil; Primary rated current: 4000 A; Output signal: 22.5 mV per kA; Cable length: 1.5 m; Feedthrough for measurement conductor: 70 mm	855-9150/2000-701
End Module	750-600
SD Memory Card; pSLC-NAND; 8 GB Temperature range: -40 ... +90 °C	758-879/000-2108
IoT Box application (installed and licensed)	
Circuit breaker; 1-pole; C 10 A; 10 kA	
Electrical circuit breaker; 1-pole; 24 VDC; 1 ... 8 A	
Set of wall-mount lugs	
Cable grips M16; M20; M25	
Connectors (plug and socket) for power supply	

Communication	ETHERNET; RS-232 interface; RS-485 interface; MQTT
ETHERNET protocols	DHCP, DNS, FTP, FTPS, HTTP, HTTPS, SSH
Transmission rate	ETHERNET: 10/100 Mbit/s
Visualization	Web-Visu
Dimensions W x H x D	300 x 300 x 210
Power supply (AC)	230 VAC (L/N/GND); 50 Hz
Weight	7.5 kg
Color	Light gray (RAL7035)
Housing material	Metal
Conformity marking	CE
Surrounding air temperature (operation)	0 ... 45 °C
Surrounding air temperature (storage)	-40 ... +85 °C
Protection type	IP20/IP65; (IP65 only applies when both power and LAN cables are locked)
Pollution degree	I
Relative humidity (without condensation)	95 %
Mounting type	Wall-mount

WAGO IoT Box; MES with Controller PFC200 (750-8212)



Integrating machines and systems into the "Internet of Things" is incredibly quick and easy with the WAGO IoT Box MES. This IoT Box also offers a wide range of communication and bus protocols for communicating with production control systems. The complete system is ready for immediate use and offers all the functions required for digitalization, from signal acquisition to cloud connectivity.

The IoT Box was designed as a plug-and-play device – no hardware engineering is needed. Collected data is transferred to the desired IoT application with just a few parameter settings.

The hardware includes a controller with its own communication interface, I/O modules with analog and digital inputs/outputs and a 24 V power supply unit.

Depending on the application, additional I/O modules can be added later to adapt the system to specific requirements.

Manufacturing Execution Systems (MES)

Item Description	Item No.
IoT Box; MES	2854-099/000-002
This IoT Box includes:	
Controller PFC200; 2nd generation; 2 x ETHERNET, RS-232/-485	750-8212
Switched-Mode Power Supply; Classic; 1-phase; Output voltage: 24 VDC; Output current: 2 A; NEC Class 2; DC OK signal	787-1606
8-Channel Digital Input; 24 VDC; 3 ms; 2-wire connection	750-1415
8-Channel Digital Output; 24 VDC; 0.5 A; 2-wire connection	750-1515
8-Channel Analog Input; resistance measurement; adjustable	750-451
4-Channel Analog Input; Voltage/current; Differential input; 16 bits; Diagnostics	750-471
End Module	750-600
SD Memory Card; pSLC-NAND; 8 GB Temperature range: -40 ... +90 °C	758-879/000-2108
Energy Data Management (EDM) application (installed and licensed)	
Circuit breaker; 1-pole; C 10 A; 10 kA	
Electrical circuit breaker; 1-pole; 24 VDC; 1 ... 8 A	
Set of wall-mount lugs	
Cable grips M16; M20; M25	
Connectors (plug and socket) for power supply	

Communication	ETHERNET; Modbus (TCP, UDP); Modbus RTU; RS-232 interface; RS-485 interface; MQTT
ETHERNET protocols	DHCP, DNS, FTP, FTPS, HTTP, HTTPS, SSH
Transmission rate	ETHERNET: 10/100 Mbit/s
Visualization	Web-Visu
Dimensions W x H x D	300 x 300 x 210
Power supply (AC)	230 VAC (L/N/GND); 50 Hz
Weight	7.5 kg
Color	Light gray (RAL7035)
Housing material	Metal
Conformity marking	CE
Surrounding air temperature (operation)	0 ... 45 °C
Surrounding air temperature (storage)	-40 ... +85 °C
Protection type	IP20/IP65; (IP65 only applies when both power and LAN cables are locked)
Pollution degree	I
Relative humidity (without condensation)	95 %
Mounting type	Wall-mount

WAGO IoT Box; Energy Data 4G with Controller PFC200 (750-8217)

6.6



Integrating machines and systems into the "Internet of Things" is incredibly quick and easy with the WAGO IoT Box Energy Data 4G.

This IoT Box features power and energy measurement functionality and is ready for immediate use. It also offers all the functions required for digitalization, from signal acquisition to cloud connectivity.

The IoT Box was designed as a plug-and-play device – no hardware engineering is needed. Collected data is transferred to the desired IoT application with just a few parameter settings.

The hardware includes a controller with its own communication interface, I/O modules with analog and digital inputs/outputs, a 3-phase power measurement module and a 24 V power supply unit.

The integrated 4G cellular modem provides a wireless connection to the Internet and includes a radio license for EU countries.

Depending on the application, additional I/O modules can be added later to adapt the system to specific requirements.

Item Description	Item No.
IoT Box; Energy Data 4G	2854-099/000-003
This IoT Box includes:	
Controller PFC200; 2nd generation; 2 x ETHERNET, RS-232/-485, 4G cellular module	750-8217
Magnetic-Mount Antenna; with 2.5 m cable and SMA plug; GSM/UMTS/LTE/Bluetooth®/WLAN; 698-960, 1400-1518, 1710-2700 MHz	758-975
Switched-Mode Power Supply; Classic; 1-phase; Output voltage: 24 VDC; Output current: 2 A; NEC Class 2; DC OK signal	787-1606
8-Channel Digital Input; 24 VDC; 3 ms; 2-wire connection	750-1415
8-Channel Digital Output; 24 VDC; 0.5 A; 2-wire connection	750-1515
8-Channel Analog Input; Resistance measurement; Adjustable	750-451
4-Channel Analog Input; Voltage/current; Differential input; 16 bits; Diagnostics	750-471
3-Phase Power Measurement; 690 VAC 1 A	750-495
Rogowski Coil; Primary rated current: 4000 A; Output signal: 22.5 mV per kA; Cable length: 1.5 m; Feedthrough for measurement conductor: 70 mm	855-9150/2000-701
End Module	750-600
SD Memory Card; pSLC-NAND; 8 GB Temperature range: -40 ... +90 °C	758-879/000-2108
IoT Box application (installed and licensed)	
Circuit breaker; 1-pole; C 10 A; 10 kA	
Electrical circuit breaker; 1-pole; 24 VDC; 1 ... 8 A	
Set of wall-mount lugs	
Cable grips M16; M20; M25	
Connectors (plug and socket) for power supply	

Communication	ETHERNET; RS-232 interface; RS-485 interface; MQTT
ETHERNET protocols	DHCP, DNS, FTP, FTPS, HTTP, HTTPS, SSH
Transmission rate	ETHERNET: 10/100 Mbit/s
Visualization	Web-Visu
Services	GPRS connection to Internet
Wireless technology	GSM/UMTS/LTE
Frequency band	GSM dual band (B3; B8); E-UTRA bands (B1; B3; B5; B7; B8; B20; B38; B40; B41)
Dimensions W x H x D	300 x 300 x 210
Power supply (AC)	230 VAC (L/N/GND); 50 Hz
Weight	7.5 kg
Color	Light gray (RAL7035)
Housing material	Metal
Conformity marking	CE
Surrounding air temperature (operation)	0 ... 45 °C
Surrounding air temperature (storage)	-40 ... +85 °C
Protection type	IP20/IP65; (IP65 only applies when both power and LAN cables are locked)
Pollution degree	I
Relative humidity (without condensation)	95 %
Mounting type	Wall-mount

WAGO IoT Box; MES 4G with Controller PFC200 (750-8217)



Integrating machines and systems into the "Internet of Things" is incredibly quick and easy with the WAGO IoT Box MES 4G. This IoT Box also offers a wide range of communication and bus protocols for communicating with production control systems. The complete system is ready for immediate use and offers all the functions required for digitalization, from signal acquisition to cloud connectivity.

The IoT Box was designed as a plug-and-play device – no hardware engineering is needed. Collected data is transferred to the desired IoT application with just a few parameter settings.

The hardware includes a controller with its own communication interface, I/O modules with analog and digital inputs/outputs and a 24 V power supply unit.

The integrated 4G cellular modem provides a wireless connection to the Internet and includes a radio license for EU countries.

Depending on the application, additional I/O modules can be added later to adapt the system to specific requirements.

Manufacturing Execution Systems (MES)

Item Description	Item No.
IoT Box; MES 4G	2854-099/000-004

This IoT Box includes:

Controller PFC200; 2nd generation; 2 x ETHERNET, RS-232/-485, 4G cellular module	750-8217
Magnetic-Mount Antenna; with 2.5 m cable and SMA plug; GSM/UMTS/LTE/Bluetooth®/WLAN; 698-960, 1400-1518, 1710-2700 MHz	758-975
Switched-Mode Power Supply; Classic; 1-phase; Output voltage: 24 VDC; Output current: 2 A; NEC Class 2; DC OK signal	787-1606
8-Channel Digital Input; 24 VDC; 3 ms; 2-wire connection	750-1415
8-Channel Digital Output; 24 VDC; 0.5 A; 2-wire connection	750-1515
8-Channel Analog Input; Resistance Measurement; Adjustable	750-451
4-Channel Analog Input; Voltage/current; Differential input; 16 bits; Diagnostics	750-471
End Module	750-600
SD Memory Card; pSLC-NAND; 8 GB Temperature range: -40 ... +90 °C	758-879/000-2108
Energy Data Management (EDM) application (installed and licensed)	
Circuit breaker; 1-pole; C 10 A; 10 kA	
Electrical circuit breaker; 1-pole; 24 VDC; 1 ... 8 A	
Set of wall-mount lugs	
Cable grips M16; M20; M25	
Connectors (plug and socket) for power supply	

Communication	ETHERNET; Modbus (TCP, UDP); Modbus RTU; RS-232 interface; RS-485 interface; MQTT
ETHERNET protocols	DHCP, DNS, FTP, FTPS, HTTP, HTTPS, SSH
Transmission rate	ETHERNET: 10/100 Mbit/s
Visualization	Web-Visu
Services	GPRS connection to Internet
Wireless technology	GSM/UMTS/LTE
Frequency band	GSM dual band (B3; B8); E-UTRA bands (B1; B3; B5; B7; B8; B20; B38; B40; B41)
Dimensions W x H x D	300 x 300 x 210
Power supply (AC)	230 VAC (L/N/GND); 50 Hz
Weight	7.5 kg
Color	Light gray (RAL7035)
Housing material	Metal
Conformity marking	CE
Surrounding air temperature (operation)	0 ... 45 °C
Surrounding air temperature (storage)	-40 ... +85 °C
Protection type	IP20/IP65; (IP65 only applies when both power and LAN cables are locked)
Pollution degree	I
Relative humidity (without condensation)	95 %
Mounting type	Wall-mount



I/O System – 750 and 753 Series

I/O System – 750 and 753 Series

- Highly versatile
- More than 500 modules available
- Functional safety
- Ex i

I/O System – 750 XTR Series

- For demanding applications in which the following are critical:
- Extreme temperature resistance
 - Immunity to electromagnetic interference and impulse voltages
 - Vibration and shock resistance

Section 8 ▶







I/O System Field

- Automate and Network Modular Machines for the Future
- Ethernet-based fieldbus standards (EtherCAT®, EtherNet/IP™, PROFINET)
 - Integrated Bluetooth® interface (Android/iOS App), OPC UA Server, Webserver
 - IO-Link Master and Devices

Section 9 ▶▶

I/O System – 750 and 753 Series

Contents

			Page
	General Product Information		192
	Variants		193
	Interfaces and Types		194
	Marking and Mounting Accessories		195
	Application and Installation Instructions		196
	Item Number Key		198
	Standards and Rated Conditions		199
	Approvals		199
	Fieldbus Couplers (FC)	PROFINET IO, PROFIBUS, Modbus/TCP, EtherNet/IP™, BACnet/IP, EtherCAT®, DeviceNet, CANopen, MODBUS, INTERBUS, CC-Link	201
	I/O Modules	Digital Input Modules (DI)	229
		Digital Output Modules (DO)	277
		Analog Input Modules (AI)	311
		Analog Output Modules (AO)	361
		Function/Technology Modules	377
		Communication Modules	397
		Functional Safety	417
		Intrinsically Safe Modules	431
		Supply and Segment Modules	449
	Accessories		Section 13
	Marking and Mounting Accessories		

I/O System – 750 and 753 Series — One System for Every Application

General Product Information

One System for Every Application

The WAGO I/O System 750/753 is distinguished by its universal use and extensive product portfolio. With more than 500 different modules, it is versatile and flexible enough to cover virtually any requirement in a huge variety of industries.

Industrial Automation

The comprehensive selection of I/O modules for different potentials and signal types saves time and money because the sensors/actuators can be wired directly – even in safety-related applications.

Building Automation

The broad portfolio enables flexible, cellar-to-ceiling solutions with conventional I/O modules, standardized industry-specific fieldbus protocols and subsystems for typical applications in lighting, shading, HVAC and much more.

Marine and Onshore/Offshore Automation

International approvals coupled with industry-specific features permit use in marine applications and other harsh sectors. Addressing requirements inherent in specific industries and operating environments has enabled use on marine diesels and in the EMC-sensitive area of a vessel's bridge. Because the requirements are significantly greater for both interference immunity and emission, along with superior mechanical performance in these sensitive areas, the WAGO I/O System will readily meet the needs of other industries.

Process Automation

Even under the harshest environmental conditions, use is possible with special approvals. Potential hazardous area applications include oil and gas production, the chemical industry and power generation. The WAGO I/O System can be installed in Zone 2/22 with its intrinsically safe I/O modules, making it possible to connect sensors/actuators in Zones 1/21 and 0/20.

Maximum Fieldbus Independence

The system's modularity is also reflected in its support for numerous fieldbus systems and ETHERNET standards. Depending on the application, it is possible to choose between fieldbus couplers and communication modules for different protocols.

Easy to Use

A modular, DIN-rail-mount design permits easy installation, expansion and modification of the I/O node without tools. The streamlined design prevents installation errors. Additionally, proven CAGE CLAMP® technology ensures that all connections made in the field are quick, vibration-proof and maintenance-free. Depending on the I/O module's granularity, field peripherals can be directly wired using 1-, 2-, 3- or 4-wire technology.

Worldwide Approvals

International approvals for building and industrial automation, as well as the process and marine industries, guarantee worldwide use. These approvals even include the rigorous operating conditions that ATEX, BR-Ex, IECEx, UL508, UL ANSI/ISA, AEx and numerous other marine certifications apply to.



Extremely Compact

WAGO's patented mechanical design leads to extremely compact I/O nodes. In fact, it can accommodate up to 16 channels in a module width of 12 mm (1/2").

- Finely granular I/O modules provide node customization.
- Space-saving design permits high-density wiring and direct connection.

Maximum Reliability and Ruggedness

The WAGO I/O System is engineered and tested for use in the most demanding environments and to the highest standards, e.g., those required in marine applications. The system differs from other products that are solely intended for industrial use through its:

- Greatly increased vibration rating
- Significantly greater immunity to interference (ESD)
- Lower emission of interference
- Larger voltage fluctuation range
- Greater durability for continuous operation in upper temperature ranges

In addition, CAGE CLAMP® spring pressure connections ensure superior reliability. Integrated QA measures in the production process and 100% function testing ensure consistent quality.

Clear Identification

Module functionality is identified via marker carriers (integrated or optional). Terminal assignment and technical data are printed onto the side of the I/O module. WAGO's WSB Marking System also allows for module- and channel-related identification.

Advantages:

- Fieldbus-independent – compatible with all prominent fieldbus protocols and ETHERNET standards
- Flexible platform adapts to diverse applications and environments
- Tested and approved worldwide
- Extensive range of accessories for marking systems and connection technologies
- Vibration-proof, fast and maintenance-free CAGE CLAMP® connections

I/O System – 750 and 753 Series Variants

Pluggable Connector



The pluggable connectors of the WAGO I/O System 753 allow quick and safe replacement. Optional coding pins prevent plugging a connector into the wrong I/O module. Replacing and connecting the I/O module requires no further action and eliminates possible errors – essentially serving as permanent wiring.

Alternatively, field wiring is possible via interface modules that can be connected to the WAGO I/O System using a ribbon cable (see "Types").

Extended Temperature Range



Industrial automation technology is typically operated in temperatures ranging from 0°C to 55°C. However, some applications require an extended temperature range.

For these applications, WAGO offers a line of WAGO I/O System 750 products for temperatures ranging from –20°C to +60°C.

For extreme applications, where even this extended temperature range is not sufficient, the WAGO I/O System 750 XTR is available.

Functional Safety



In the European Union, the machinery directive defines the requirements for machine and system safety. This ensures a uniform standard for protecting the "life and limb" of workers within a machine's operating area.

The required risk assessment is based on harmonized standards (e.g., EN 13849) and identifies existing risks and required risk reduction (SIL or PL quality). Based on the risk assessment, safety functions can be implemented, e.g., by presence detection or protection zone violations, using secure switches or light arrays to shut down the "risk" immediately. For this purpose, the safety signals are detected by the "yellow" safety modules and transmitted via "PROFIsafe" to the fail-safe PLC for additional processing. The result is then executed via safe actuator (e.g., output module or controller).

The unique safety characteristics of the WAGO modules facilitate calculation of the final safety function up to Cat. 4/PLe according to EN 13849, or SIL3 according to EN 62061 or IEC 61511.

The mixed operation of safe and conventional I/O modules streamlines system configuration. For increased electromagnetic immunity (EMC standard), WAGO offers compact power supply filter modules. Specific power supply features must be considered, which are described in the corresponding manuals.

Use in Hazardous Areas



In many plants across the chemical and petrochemical industries, as well as in the production and process automation sectors, installations are operated that process explosive gas- or dust-air mixtures. This is why electrical equipment must be explosion-proof to avoid injuries to personnel and damage to facilities.

The modules within the WAGO I/O System 750 are designed for use in both non-hazardous and hazardous areas.

The direct application of fieldbus technology in hazardous areas is typically resource-intensive. When used in hazardous areas of Zone 2/22, the I/O System 750 offers a safe, easy and economical connection to the sensors/actuators of Zones 0/20 and 1/21. The "blue" Ex i I/O modules were specially developed for this purpose. They form an intrinsically safe section that can be integrated into a standard fieldbus node, offering all the advantages of state-of-the-art fieldbus technology. The WAGO I/O System 750 is also approved for mining applications.

I/O System – 750 and 753 Series Interfaces and Types

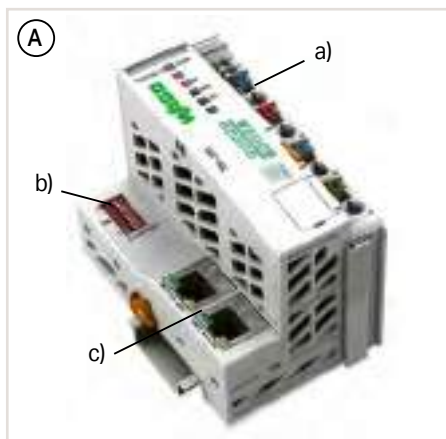

Housing Design: Fieldbus Coupler (A)

- Includes a supply module (a) to power downstream I/O modules
- Technical differences on the connection level; optional addressing switch (b) and fieldbus interface (c)
- W x H x D (mm) 50.5 x 100 x 71.1 or
- W x H x D (mm): 61.5 x 100 x 71.9

Housing Design: Fieldbus Coupler Eco (B)

- Restriction on power supply and data width
- W x H x D (mm): 49.5 x 96.8 x 71.9

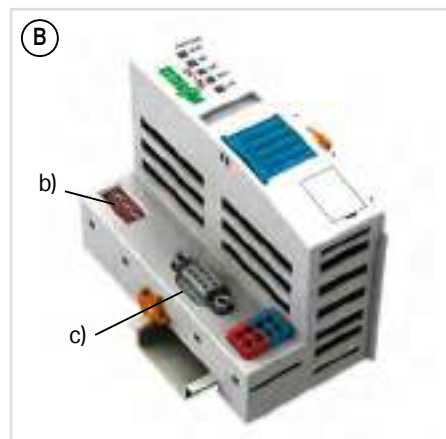

Housing Design: 750 (C)

- 8 connection points (CAGE CLAMP®)
- W x H x D (mm) 12 x 69.8 x 100 (4 LEDs)
- W x H x D (mm) 12 x 67.8 x 100 (8 LEDs)

Housing Design: 753 (D)

- Pluggable connector
- 8 connection points (CAGE CLAMP®)
- W x H x D (mm) 12 x 100 x 69.8 (4 LEDs)
- W x H x D (mm) 12 x 100 x 69 (8 LEDs)
- Pluggable connectors and coding fingers are not included.

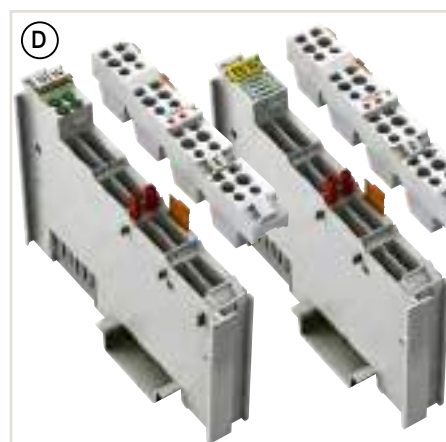

Housing Design: 750 (E)

- 16 connection points (Push-in CAGE CLAMP®)
- W x H x D (mm): 12 x 100 x 69

Housing Design (F)

- For time-saving wiring between I/O system and interface modules
- Ribbon cable connection to interface modules (289 and 704 Series) and interface adapter
- W x H x D (mm): 12 x 100 x 74.1



Housing Design: Double Width (G)

- Some modules are integrated into a double housing to address specific technological needs. Despite utilizing the same standardized housing, these modules are twice as wide.
- W x H x D (mm): 24 x 100 x 69.8

Specialty Housing Design (H)

- Some modules are integrated into a specialty housing with a specific width and pluggable connectors. The dimensions are specified on the respective catalog pages.



I/O System – 750 and 753 Series Marking and Mounting Accessories



Transparent group marker carriers indicate module type by color.



Removable group marker carriers are available for all 750 and 753 Series I/O Modules with a maximum of four LEDs, as well as all fieldbus couplers with a supply module.

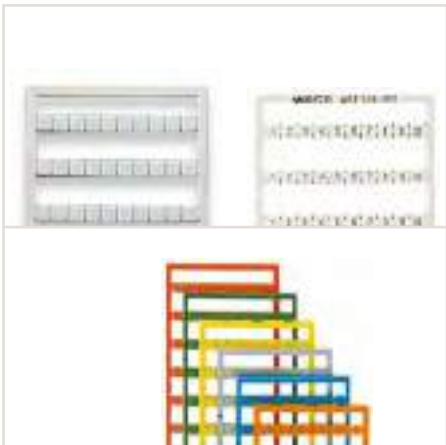

Mini-WSB marking cards (blank, pre-marked or colored) are suitable for all 750 and 753 Series I/O Modules.



Marker carrier for a single I/O module (suitable for all 750 and 753 Series I/O Modules); the marker carrier can be accommodated in the upper Mini-WSB marker slot.



Marker carrier for one I/O node; both models (750-106 and 750-107) permit continuous marking regardless of the I/O module housing used.



Interface modules for system wiring



WAGO system cables

7

I/O System – 750 and 753 Series

Application and Installation Instructions

Power Supply

The fieldbus coupler powers the internal electronics. The field-side power supply is electrically isolated via the supply module on the coupler or a separate power supply module. This division enables a separate supply for sensors and actuators. Snapping the I/O modules together automatically routes the supply voltages (system power supply 5 VDC via the data contacts and field supply via the optional power jumper contacts). Supply modules with diagnostics also enable power supply monitoring. This ensures a flexible and customized supply configuration for a fieldbus node.

Power supply to the electronics is limited by a maximum value. This value depends on the fieldbus coupler used. If the sum of the internal current demand of all the I/O modules should exceed this value, an additional system supply module is necessary. Furthermore, the current consumed for field-side supply must not exceed 10 A. A variety of power supply modules allows re-feeding, creating potential groups and implementing emergency stops.

Interference-Free in Safety-Related Applications

To easily and safely perform a cost-effective and centralized deactivation of complete actuator groups, the actuator's power supply can be switched off using a safety switching device. This can either be performed for each individual actuator or by turning off the power supply to a group of control outputs. In the event of failure, ensure that no interference from other current or power circuits occurs – even when the control voltage is switched off – so the defined safety function properties (logic and time response) remain unchanged.

Some modules are designed to provide interference-free safety functionality. These modules comply with safety requirements up to Category 4 of DIN EN ISO 13849-1:2007. Safety category and performance level depend solely on the safety components and their wiring.

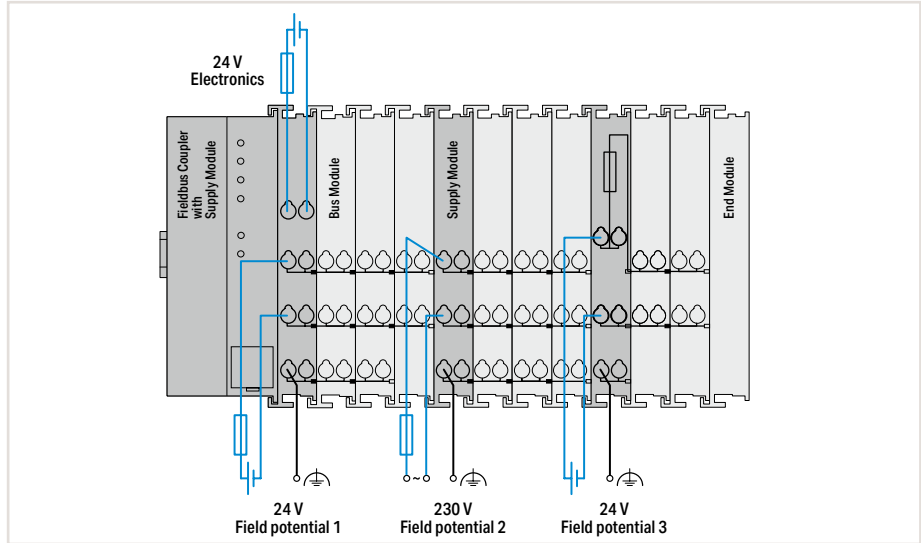

Notice:

WAGO's interference-free I/O modules are not a component of the safety function and do not replace the safety switching device! When using the components in safety functions, the corresponding notes must be observed in the relevant manual.

Notes:

Additional steps must be implemented based on where the I/O system is installed:

Specific power and field-side power supply filters (750-624 or 750-626) are required for marine and onshore/offshore applications.

A specific supply module (750-606) is required to operate intrinsically safe Ex i modules.

Additionally, both supply modules and field-side power supply filters are recommended when operating intrinsically safe Ex i modules for marine and onshore/offshore applications.

For the 24 VDC power supply of electronics and field, PELV/SELV power supply units are recommended. As part of safety-related applications, they are mandatory. The mixed operation of safe and conventional I/O modules streamlines system configuration. For increased electromagnetic immunity (EMC standard), WAGO offers compact power supply filter modules. Please refer to the manual for details about the power supply's design.

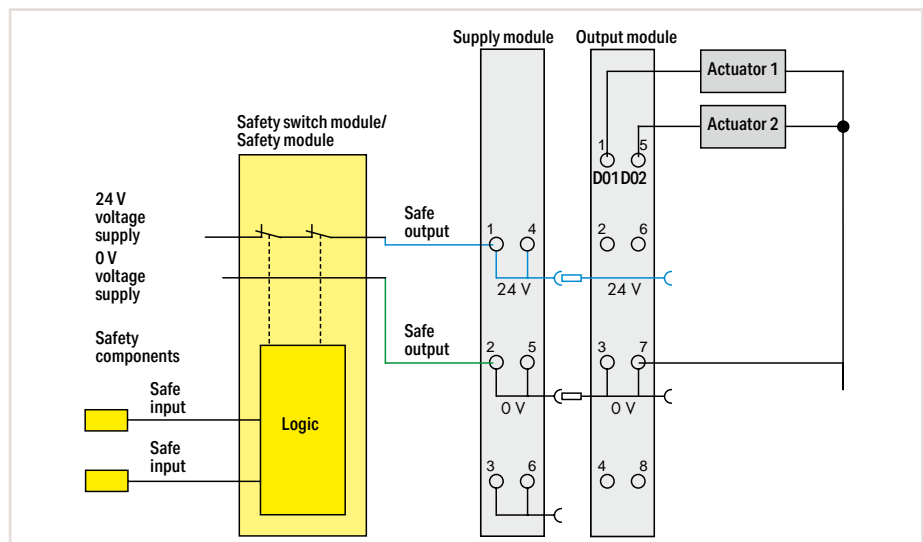

Example: 2-channel, double-pole power supply disconnection

I/O System – 750 and 753 Series

Application and Installation Instructions



Securing/removing a module from the DIN-rail



Removing a pluggable connector



Optional protection against mismatching of a pluggable connector via coding elements



Service interface for configuring the fieldbus coupler; connectivity via configuration cable or radio adapter

Notice:

Some I/O modules do not provide all power jumper contacts. Therefore, a module with three power jumper contacts (e.g., 2-channel digital input) cannot be connected to a module that does not have all power jumper contacts.

To increase electromagnetic compatibility (EMC), some components are connected to the DIN-rail via a discharge contact. The DIN-rail must always have a low-resistance connection to the ground potential.



Wide range of accessories available for EMC-compliant installation, including shield connection



Secure, automatic power supply connection via self-cleaning blade contacts



Secure, automatic data and electronics power supply connection via gold-plated pressure contacts



Securing a cable to the connector

I/O System – 750 and 753 Series

Item Number Key

Explanation of an item number key's components:

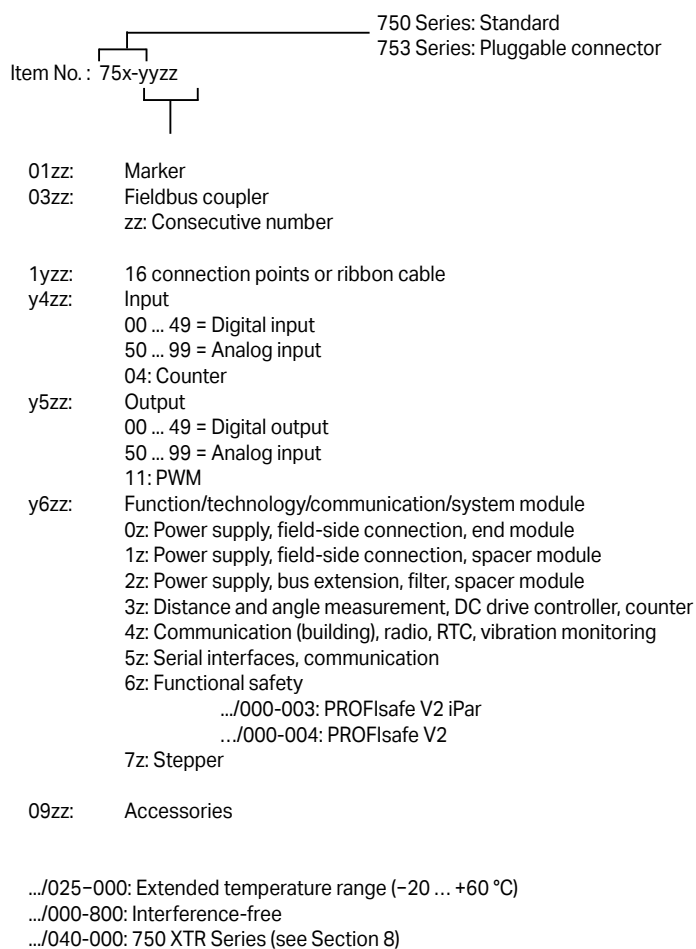

I/O System – 750 and 753 Series Standards and Rated Conditions

General Technical Data	
System supply voltage	24 VDC (-25 % ... +30 %)*; *for all marine-certified fieldbus couplers and I/O modules
Isolation	500 V (system/supply)
Surrounding air temperature (operation)	0 ... +55 °C
Surrounding air temperature (operation) for versions with an extended temperature range	-20 ... +60 °C
Surrounding air temperature (storage)	-25 ... +85 °C
Surrounding air temperature (storage) for versions with an extended temperature range	-40 ... +85 °C
Relative humidity	95 % (non-condensing)
Relative humidity for versions with an extended temperature range	Max. 95 %; short-term condensation per Class 3K6 / IEC EN 60721-3-3 and E DIN 40046-721-3, taking a temperature range of -20 to +60 °C into consideration (except wind-driven precipitation, water and ice formation)
Operating altitude	0 ... 2000 m / 0 ... 6562 ft
Pollution degree	2 per IEC 61131-2
Vibration resistance	0.5g (4g for all marine-certified fieldbus couplers and I/O modules) per IEC 60068-2-6
Shock resistance	15g per IEC 60068-2-27
EMC immunity to interference	Per EN 61000-6-2
EMC emission of interference	Per EN 61000-6-3; EN 61000-6-4
Protection class	IP20
Mounting type	DIN-35 rail mounting
Housing material	Polycarbonate; polyamide 6.6
Exposure to pollutants	Per IEC 60068-2-42 and IEC 60068-2-43
Permissible SO ₂ contaminant concentration at a relative humidity < 75 %	25 ppm
Permissible H ₂ S contaminant concentration at a relative humidity < 75 %	10 ppm
Connection technology	CAGE CLAMP®
Conductor cross-section; strip length for:	
Standard modules and couplers	0.08 ... 2.5 mm ² /28 ... 14 AWG; 8 ... 9 mm/0.31 ... 0.35 inch
I/O modules (753 Series)	0.08 ... 2.5 mm ² /28 ... 14 AWG; 9 ... 10 mm/0.35 ... 0.39 inch
Fieldbus couplers (ECO)	0.08 ... 1.5 mm ² /28 ... 16 AWG; 5 ... 6 mm/0.2 ... 0.24 inch
Connection technology	Push-in CAGE CLAMP®
Conductor cross-section; strip length for:	
I/O modules with 16 connection points	Solid: 0.08 ... 1.5 mm ² /28 ... 16 AWG, Fine-stranded: 0.25 ... 1.5 mm ² /22 ... 16 AWG; 8 ... 9 mm/0.31 ... 0.35 inch
Current carrying capacity (power jumper contacts)	10 A

7

Approvals

For approvals overview (item comparison), see Section 14 (Technical Section) or visit www.wago.com.



Fieldbus Couplers

Housing Design I with Field Supply

Dimensions W x H x D	50.5 x 100 x 71.1 mm
Height from upper edge of DIN-rail	63.9 mm
Connection technology (system supply and field supply)	CAGE CLAMP®
Conductor cross-section	0.08 ... 2.5 mm ² / 28 ... 14 AWG
Strip length	8 ... 9 mm / 0.33 inch



Housing Design II with Field Supply

Dimensions W x H x D	61.5 x 100 x 71.9 mm
Height from upper edge of DIN-rail	64.7 mm
Connection technology (system supply and field supply)	CAGE CLAMP®
Conductor cross-section	0.08 ... 2.5 mm ² / 28 ... 14 AWG
Strip length	8 ... 9 mm / 0.33 inch



Housing Design without Field Supply

Dimensions W x H x D	49.5 x 96.8 x 71.9 mm
Height from upper edge of DIN-rail	64.7 mm
Connection technology (system supply)	CAGE CLAMP®
Conductor cross-section	0.08 ... 1.5 mm ² / 28 ... 16 AWG
Strip length	5 ... 6 mm / 0.22 inch















Housing Design "Eco" (without Field Supply)

Dimensions W x H x D	49.5 x 96.8 x 71.9 mm
Height from upper edge of DIN-rail	64.7 mm
Connection technology (system supply)	CAGE CLAMP®
Conductor cross-section	0.08 ... 1.5 mm ² / 28 ... 16 AWG
Strip length	5 ... 6 mm / 0.22 inch



I/O System – 750 and 753 Series, Fieldbus Couplers

Contents

Fieldbus System	Housing Design				Description	Item No.	Page
	With Field Supply		Without Field Supply	Eco			
							
		<input type="checkbox"/>			PROFINET IO; 3rd Generation; Advanced	750-375	202
		<input type="checkbox"/>			PROFINET IO; 3rd Generation; Ext. Temperature; Advanced	750-375/025-000	202
			<input type="checkbox"/>		PROFINET IO; 3rd Generation; Eco Advanced	750-377	203
			<input type="checkbox"/>		PROFINET IO; 3rd Generation; Ext. Temperature; Eco Advanced	750-377/025-000	203
	<input type="checkbox"/>				PROFIBUS DP; 1st Generation; 12 MBd	750-303	204
	<input type="checkbox"/>				PROFIBUS DP; 2nd Generation; 12 MBd	750-333*	205
	<input type="checkbox"/>				PROFIBUS DP; 2nd Generation; 12 MBd; Ext. Temperature	750-333/025-000	205
				<input type="checkbox"/>	PROFIBUS DP; 12 MBd; Eco	750-343	206
	<input type="checkbox"/>				PROFIBUS DP; Fiber-Optic Connection; 1.5 MBd	750-331	207
MODBUS/TCP			<input type="checkbox"/>		Modbus TCP; 4th Generation	750-362*	208
		<input type="checkbox"/>			Modbus TCP; 4. Generation	750-362/000-001	208
			<input type="checkbox"/>		EtherNet/IP™; 4th Generation; Device Level Ring	750-366	209
			<input type="checkbox"/>		EtherNet/IP™; 4th Generation; ECO	750-363*	210
	<input type="checkbox"/>				ETHERNET; 1st Generation	750-342	211
		<input type="checkbox"/>			BACnet/IP	750-332	212
			<input type="checkbox"/>		EtherCAT®	750-354	213
			<input type="checkbox"/>		EtherCAT®; ID Switch	750-354/000-001	214
			<input type="checkbox"/>		EtherCAT®; ID Switch; Diagnostics	750-354/000-002	214
Modbus®	<input type="checkbox"/>				Modbus®; RS-485; 115.2 kBd	750-315/300-000	215
	<input type="checkbox"/>				Modbus®; RS-232; 115.2 kBd	750-316/300-000	216
	<input type="checkbox"/>				DeviceNet	750-306	217
				<input type="checkbox"/>	DeviceNet; Eco	750-346	218
	<input type="checkbox"/>				CANopen; MCS	750-337	219
	<input type="checkbox"/>				CANopen; MCS; Ext. Temperature	750-337/025-000	219
	<input type="checkbox"/>				CANopen; D-Sub	750-338*	220
				<input type="checkbox"/>	CANopen; MCS; Eco	750-347	221
				<input type="checkbox"/>	CANopen; D-Sub; Eco	750-348	222
	<input type="checkbox"/>				INTERBUS	750-304	223
				<input type="checkbox"/>	INTERBUS; 500 kbit/s; Eco	750-344	224
	<input type="checkbox"/>				CC-Link	750-310	225
		<input type="checkbox"/>			CC-Link; 156 kBd ... 10 Mbaud	750-325	226

*This coupler is also available as a 750 XTR Series variant.

See Section 8

Fieldbus couplers ► PROFINET IO; Advanced



750-375

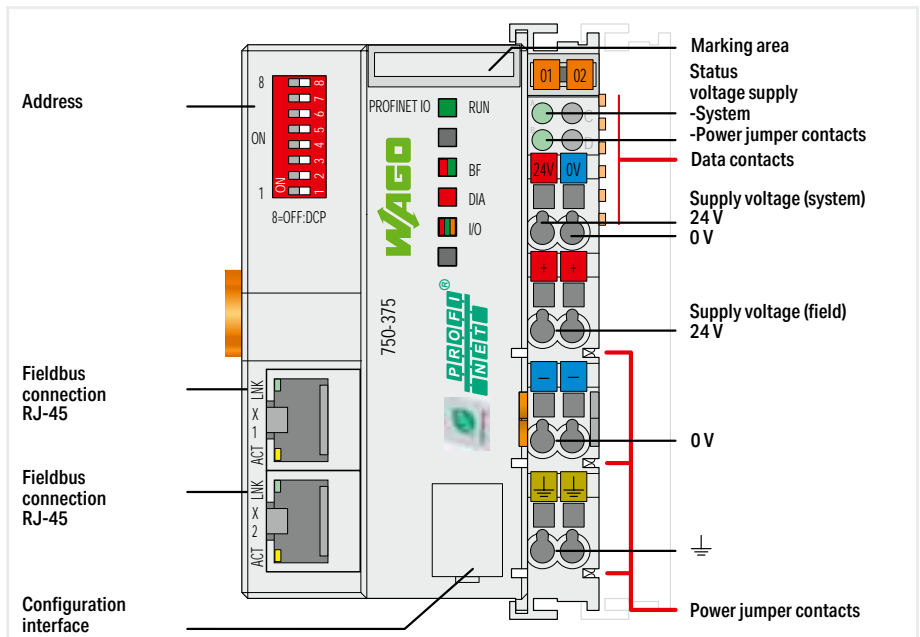

7.1

Version	Standard	ext. temperature
Item no.	750-375	750-375/025-000
Order Text	FC PROFINET; G3; Adv	FC PROFINET; G3; T; Adv

Technical data	PROFINET IO	
Communication	PROFINET IO V2.3 (conformity class C); Topology detection / LLDP; Network diagnostics / SNMP / MIB-2; Media redundancy / MRP; Webserver / HTTP; Shared device	
Protocols	PROFINET IO: 2 x RJ-45	
Connection technology: communication/fieldbus	Integrierter 2-Port-Switch; Autonegotiation; Auto-MDIX; isochrone Echtzeitkommunikation; Sendetakt: 1 ms (RT); 1, 2, 4 ms (IRT); Gerätetausch ohne Programmiergerät	
PROFINET IO features	Supported profiles: PROFIsafe V2, PROFlenergy V1.0; ID code: Vendor ID: 0x011D; Device ID: 0x02EE; Module ID: 0x01000177 (firmware version 01, 02), 0x02000177 (from firmware version 03)	
Device-specific	10/100 Mbit/s (10 Mbit/s (ETHERNET protocols), 100 Mbit/s full duplex (PROFINET IO))	
Baud rate	Twisted pair S-UTP; 100 Ω; Cat. 5	
Transmission medium (communication/fieldbus)	250	
Number of modules per node (max.)	512 bytes/512 bytes	
Input and output process image (fieldbus) max.	24 VDC (-25 ... +30 %); via pluggable connector (CAGE CLAMP® connection)	
Supply voltage (system)	24 VDC (-25 ... +30 %); via power jumper contacts	
Supply voltage (field)	500 mA	
Input current (typ.) at nominal load (24 V)	450 mA	
Current consumption (5 V system supply)	1700 mA	
Total current (system supply)	0 ... +55 °C	
Ambient temperature (operation)	-20 ... +60 °C	
Dimensions W x H x D	(61.5 x 100 x 71.9) mm	
Approvals	CE; Marine; OrdLoc/HazLoc; ATEX/IECEx	
For data sheet and additional information, see:	wago.com/750-375	

Fieldbus couplers ► PROFINET IO; ECO Advanced



750-377

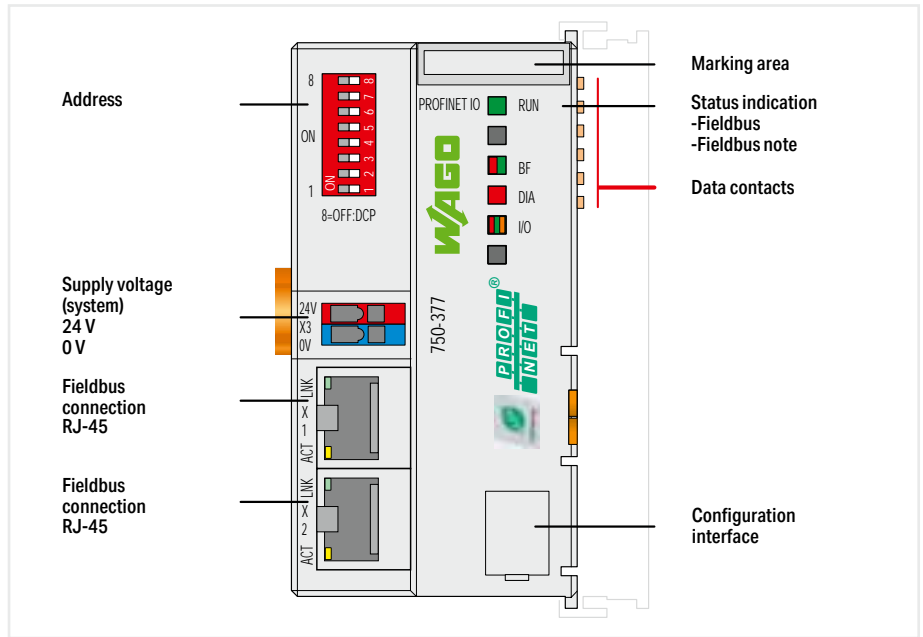

Version	
Item no.	
Order Text	

Standard	ext. temperature
750-377	750-377/025-000
FC PROFINET; G3; ECO Adv	FC PROFINET; G3; T; ECO Adv

Technical data	
Communication	
Protocols	
Connection technology: communication/fieldbus	
PROFINET IO features	
Device-specific	
Baud rate	
Transmission medium (communication/fieldbus)	
Number of modules per node (max.)	
Input and output process image (fieldbus) max.	
Supply voltage (system)	
Input current (typ.) at nominal load (24 V)	
Current consumption (5 V system supply)	
Total current (system supply)	
Ambient temperature (operation)	
Dimensions W x H x D	
Approvals	

	PROFINET IO
	PROFINET IO V2.3 (conformity class C); Topology detection / LLDP; Network diagnostics / SNMP / MIB-2; Media redundancy / MRP; Webserver / HTTP
	PROFINET IO: 2 x RJ-45
	Integrierter 2-Port-Switch; Autonegotiation; Auto-MDIX; isochrone Echtzeitkommunikation; Sendetakt: 1 ms (RT); 1, 2, 4 ms (IRT); Gerätetausch ohne Programmiergerät
	Supported profiles: PROFIsafe V2, PROFIenergy V1.0; ID code: Vendor ID: 0x011D; Device ID: 0x02EE; Module ID: 0x01000177 (firmware version 01, 02), 0x02000177 (from firmware version 03)
	10/100 Mbit/s (10 Mbit/s (ETHERNET protocols), 100 Mbit/s full duplex (PROFINET IO))
	Twisted pair S-UTP; 100 Ω; Cat. 5
	64
	256 bytes/256 bytes
	24 VDC (-25 ... +30 %); via pluggable connector
	280 mA
	450 mA
	700 mA
	0 ... +55 °C
	-20 ... +60 °C
	(49.5 x 96.8 x 71.9) mm
	CE; Marine; OrdLoc/HazLoc; ATEX/IECEX

For data sheet and additional information, see:

wago.com/750-377

Fieldbus couplers ► PROFIBUS DP; 1st generation



750-303

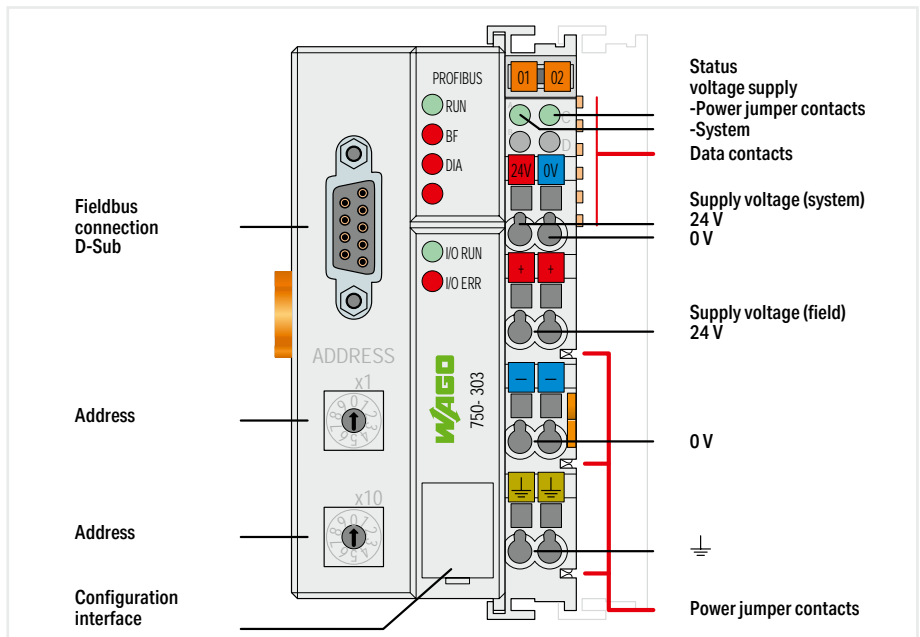

7.1

Version	Standard
Item no.	750-303
Order Text	FC PROFIBUS; G1; 12MBd

Technical data	
Communication	PROFIBUS
Protocols	PROFIBUS DP/FMS
Connection technology: communication/fieldbus	PROFIBUS: 1 x D-sub 9 socket
Number of fieldbus nodes on master (max.)	96
Baud rate	9.6 kBd ... 12 MBd
Transmission medium (communication/fieldbus)	Cu cable per EN 50170
Number of modules per node (max.)	64
Input and output process image (fieldbus) max.	128 bytes/128 bytes
Supply voltage (system)	24 VDC (-25 ... +30 %); via pluggable connector (CAGE CLAMP® connection)
Supply voltage (field)	24 VDC (-25 ... +30 %); via power jumper contacts
Input current (typ.) at nominal load (24 V)	500 mA
Current consumption (5 V system supply)	350 mA
Total current (system supply)	1650 mA
Ambient temperature (operation)	0 ... +55 °C
Dimensions W x H x D	(50.5 x 100 x 71.1) mm
Approvals	CE; Marine; OrdLoc/HazLoc; ATEX/IECEx
For data sheet and additional information, see:	wago.com/750-303

Fieldbus couplers ► PROFIBUS DP; 2nd generation



750-333

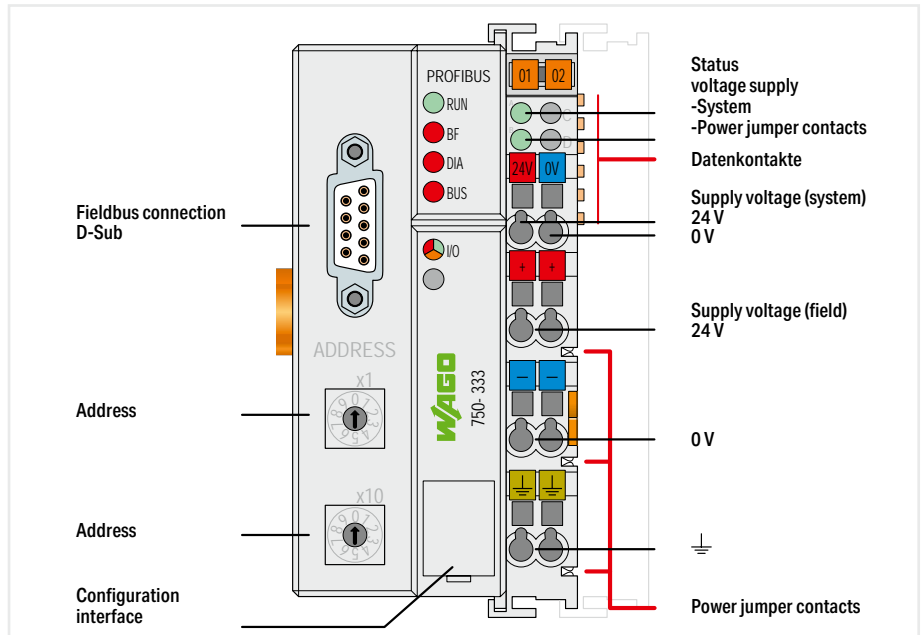

Version	Standard	ext. temperature
Item no.	750-333	750-333/025-000
Order Text	FC PROFIBUS; G2; 12MBd	FC PROFIBUS; G2; 12MBd; T

Technical data		
Communication	PROFIBUS	
Protocols	PROFIBUS DP/V1	
Connection technology: communication/fieldbus	PROFIBUS: 1 x D-sub 9 socket	
Number of fieldbus nodes on master (max.)	96	
Baud rate	9.6 kBd ... 12 MBd	
Transmission medium (communication/fieldbus)	Cu cable per EN 50170	
Number of modules per node (max.)	63	
Input and output process image (fieldbus) max.	244 bytes/244 bytes	
Supply voltage (system)	24 VDC (-25 ... +30 %); via pluggable connector (CAGE CLAMP® connection)	
Supply voltage (field)	24 VDC (-25 ... +30 %); via power jumper contacts	
Input current (typ.) at nominal load (24 V)	500 mA	
Current consumption (5 V system supply)	200 mA	
Total current (system supply)	1800 mA	
Ambient temperature (operation)	0 ... +55 °C	-20 ... +60 °C
Dimensions W x H x D	(50.5 x 100 x 71.1) mm	
Approvals	Marine; OrdLoc/HazLoc; ATEX/IECEx	
For data sheet and additional information, see:	wago.com/750-333	

Fieldbus couplers ► PROFIBUS DP; ECO



750-343

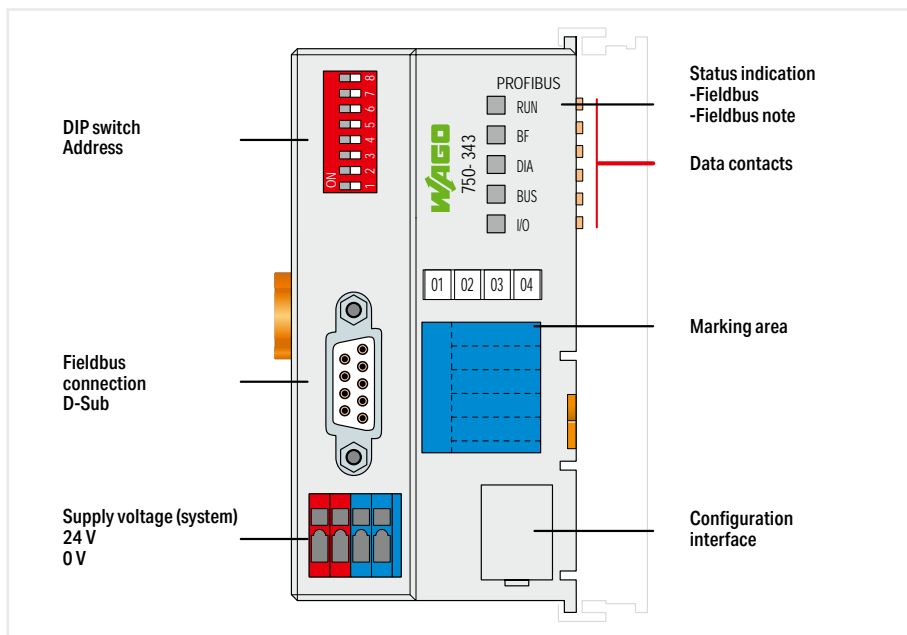

Version
Item no.
Order Text

Standard
750-343
FC PROFIBUS; 12MBd; ECO

Technical data
Communication
Protocols
Connection technology: communication/fieldbus
Number of fieldbus nodes on master (max.)
Baud rate
Transmission medium (communication/fieldbus)
Number of modules per node (max.)
Input and output process image (fieldbus) max.
Supply voltage (system)
Input current (typ.) at nominal load (24 V)
Current consumption (5 V system supply)
Total current (system supply)
Ambient temperature (operation)
Dimensions W x H x D
Approvals
For data sheet and additional information, see:

PROFIBUS
PROFIBUS DP
PROFIBUS: 1 x D-sub 9 socket
125
9.6 kBd ... 12 MBd
Cu cable per EN 50170
63
32 bytes/32 bytes
24 VDC (-25 ... +30 %); via pluggable connector
260 mA
350 mA
650 mA
0 ... +55 °C
(49.5 x 96.8 x 71.9) mm
CE; Marine; OrdLoc/HazLoc; ATEX/IECEx
wago.com/750-343

Fieldbus couplers ► PROFIBUS DP; fiber-optic connection



750-331

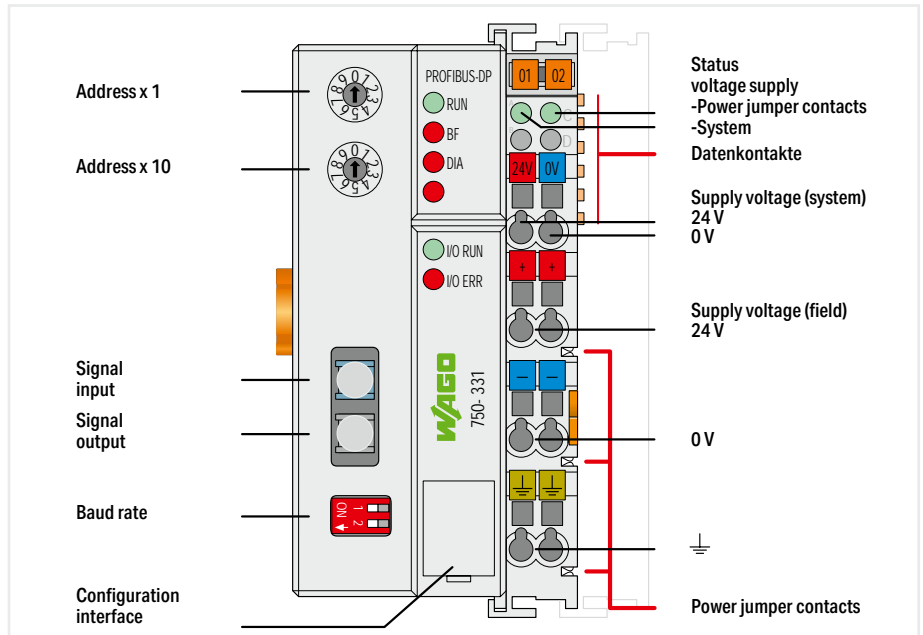

Version
Item no.
Order Text

Standard
750-331
FC PROFIBUS; FOC; 1.5MBd

Technical data
Communication
Protocols
Connection technology: communication/fieldbus
Number of fieldbus nodes on master (max.)
Baud rate
Transmission medium (communication/fieldbus)
Number of modules per node (max.)
Input and output process image (fieldbus) max.
Supply voltage (system)
Supply voltage (field)
Input current (typ.) at nominal load (24 V)
Current consumption (5 V system supply)
Total current (system supply)
Ambient temperature (operation)
Dimensions W x H x D
Approvals

PROFIBUS
PROFIBUS DP
PROFIBUS: 1 x HP Simplex, FOC plug included with delivery
10
93.75 kBd ... 1.5 MBd
APF (All Plastic Fiber) (1000 µm)
64
128 bytes/128 bytes
24 VDC (-15 ... +20 %); via pluggable connector (CAGE CLAMP® connection)
24 VDC (-15 ... +20 %); via power jumper contacts
500 mA
350 mA
1650 mA
0 ... +55 °C
(50.5 x 100 x 71.1) mm
CE; OrdLoc

For data sheet and additional information, see:

wago.com/750-331

Fieldbus couplers ▶ Modbus TCP; ECO



750-362

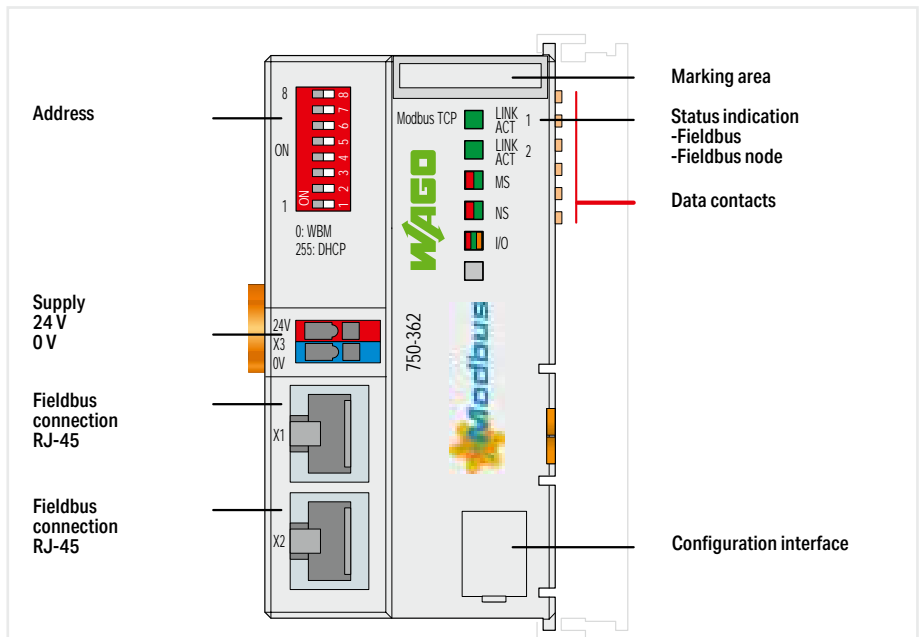

Version	Standard	BootP is preset
Item no.	750-362	750-362/000-001
Order Text	FC Modbus TCP; G4	

7.1

Technical data	
Communication	Modbus (TCP, UDP)
ETHERNET protocols	HTTP(S); BootP; DHCP; DNS; SNTP; FTP(S); SNMP
Connection technology: communication/fieldbus	Modbus (TCP, UDP); 2 x RJ-45
Baud rate	10/100 Mbit/s
Transmission medium (communication/fieldbus)	Twisted pair S-UTP; 100 Ω; Cat. 5; 100 m maximum cable length
Transmission performance	Class D per EN 50173
Number of modules per node (max.)	250
Input and output process image (fieldbus) max.	1020 words/1020 words
Supply voltage (system)	24 VDC (-25 ... +30 %); via pluggable connector
Input current (typ.) at nominal load (24 V)	280 mA
Current consumption (5 V system supply)	350 mA
Total current (system supply)	700 mA
Ambient temperature (operation)	0 ... +55 °C
Dimensions W x H x D	(49.5 x 96.8 x 71.9) mm
Approvals	CE, Marine; OrdLoc/HazLoc; ATEX/IECEX
For data sheet and additional information, see:	wago.com/750-362

Fieldbus couplers ▶ EtherNet/IP™



750-366

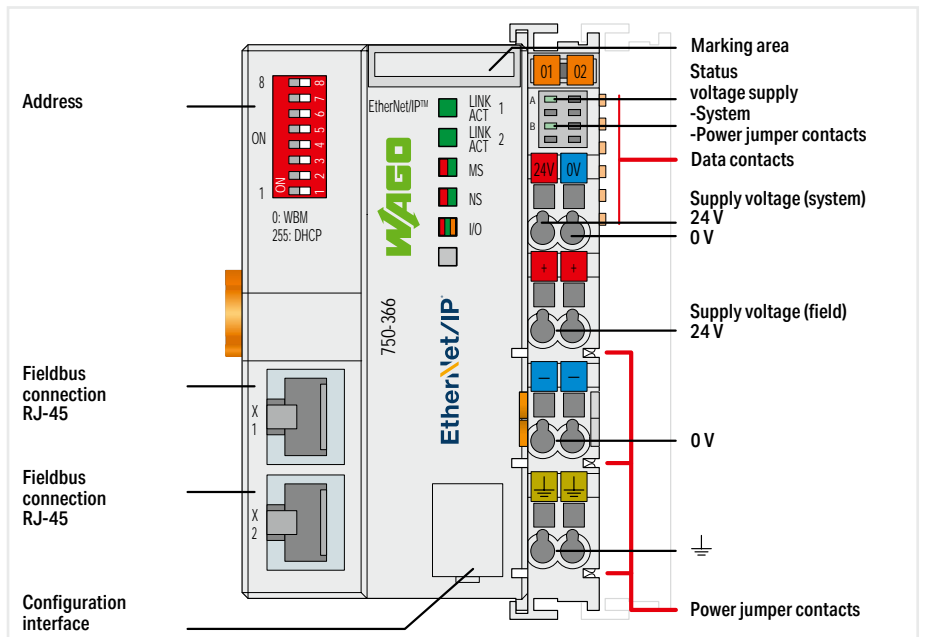

Version
Item no.
Order Text

Standard
750-366
FC EtherNet/IP™; G4; DLR

Technical data
Communication
ETHERNET protocols
Connection technology: communication/fieldbus
Baud rate
Transmission medium (communication/fieldbus)
Transmission performance
Number of modules per node (max.)
Input and output process image (fieldbus) max.
Supply voltage (system)
Supply voltage (field)
Input current (typ.) at nominal load (24 V)
Current consumption (5 V system supply)
Total current (system supply)
Ambient temperature (operation)
Dimensions W x H x D
Approvals

EtherNet/IP™
HTTP(S); BootP; DHCP; DNS; FTP(S); SNMP
EtherNet/IP™: 2 x RJ-45
10/100 Mbit/s
Twisted pair S-UTP; 100 Ω; Cat. 5; 100 m maximum cable length
Class D per EN 50173
250
1020 words/1020 words
24 VDC (-25 ... +30 %); via pluggable connector (CAGE CLAMP® connection)
24 VDC (-25 ... +30 %); via power jumper contacts
480 mA
300 mA
1700 mA
0 ... +55 °C
(62 x 100 x 71.9) mm
CE; Marine; OrdLoc/HazLoc

For data sheet and additional information, see:

wago.com/750-366

Fieldbus couplers ▶ EtherNet/IP™; ECO



750-363

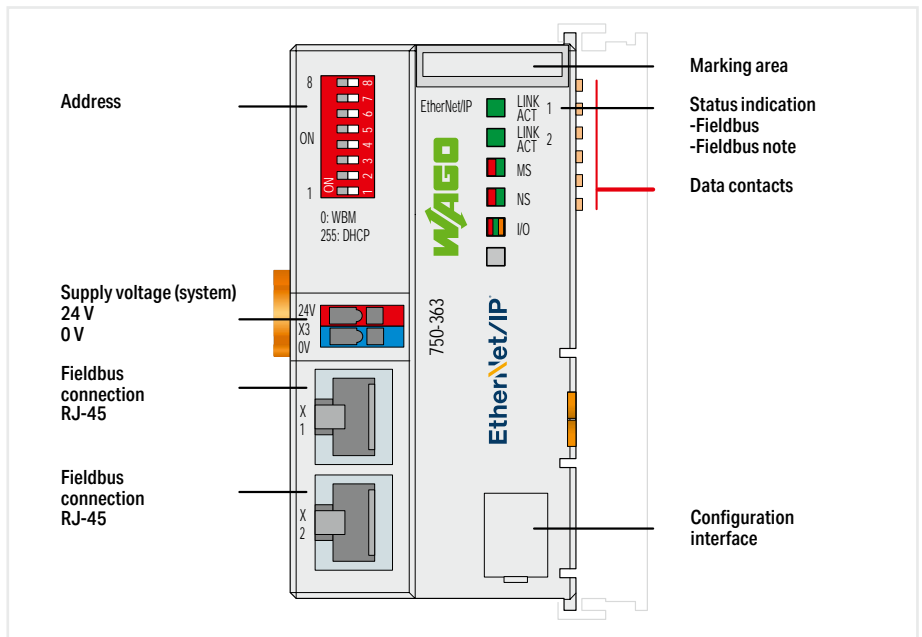

Version	
Item no.	
Order Text	

Standard	
750-363	
FC EtherNet/IP™	

7.1

Technical data	
Communication	EtherNet/IP™
ETHERNET protocols	HTTP(S); BootP; DHCP; DNS; SNMP; FTP(S); SNMP
Connection technology: communication/fieldbus	EtherNet/IP™: 2 x RJ-45
Baud rate	10/100 Mbit/s
Transmission medium (communication/fieldbus)	Twisted pair S-UTP; 100 Ω; Cat. 5; 100 m maximum cable length
Transmission performance	Class D per EN 50173
Number of modules per node (max.)	250
Input and output process image (fieldbus) max.	1020 words/1020 words
Supply voltage (system)	24 VDC (-25 ... +30 %); via pluggable connector
Input current (typ.) at nominal load (24 V)	280 mA
Current consumption (5 V system supply)	350 mA
Total current (system supply)	700 mA
Ambient temperature (operation)	0 ... +55 °C
Dimensions W x H x D	(49.5 x 96.8 x 71.9) mm
Approvals	CE; Marine; OrdLoc/HazLoc; ATEX/IECEx
For data sheet and additional information, see:	wago.com/750-363

Fieldbus couplers ► ETHERNET



750-342

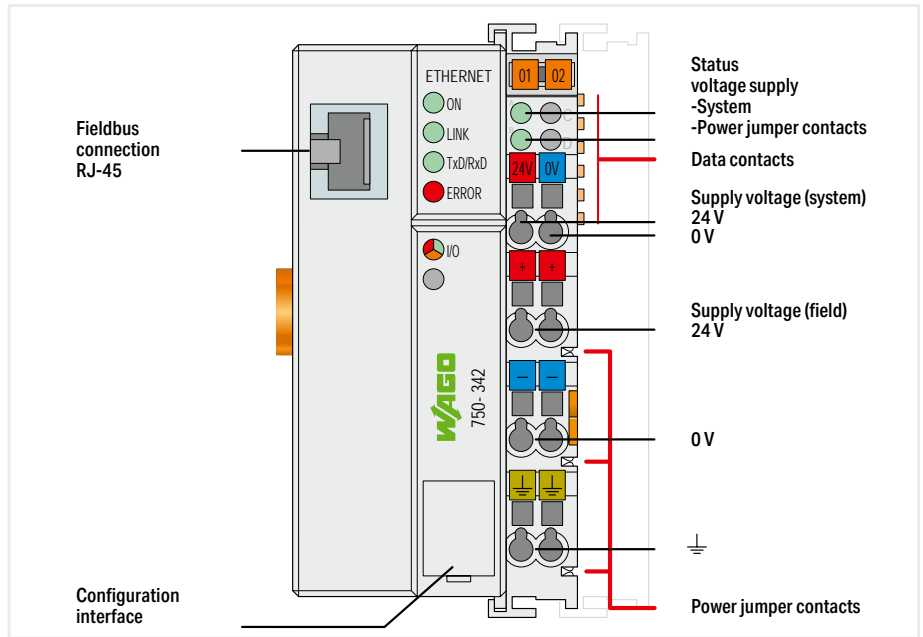

Version	
Item no.	
Order Text	

Standard	
750-342	
FC ETHERNET; G1	

Technical data	
Communication	Modbus (TCP, UDP); ETHERNET
ETHERNET protocols	HTTP; BootP
Connection technology: communication/fieldbus	Modbus (TCP, UDP); 1 x RJ-45
Baud rate	10 Mbit/s
Transmission medium (communication/fieldbus)	Twisted pair S-UTP; 100 Ω; Cat. 5
Number of modules per node (max.)	64
Input and output process image (fieldbus) max.	512 bytes/512 bytes
Supply voltage (system)	24 VDC (-25 ... +30 %); via pluggable connector (CAGE CLAMP® connection)
Supply voltage (field)	24 VDC (-25 ... +30 %); via power jumper contacts
Input current (typ.) at nominal load (24 V)	500 mA
Current consumption (5 V system supply)	200 mA
Total current (system supply)	1800 mA
Ambient temperature (operation)	0 ... +55 °C
Dimensions W x H x D	(50.5 x 100 x 71.1) mm
Approvals	CE; Marine; OrdLoc/HazLoc; ATEX/IECEx
For data sheet and additional information, see:	wago.com/750-342

Fieldbus couplers ▶ BACnet/IP; SD card slot



750-332

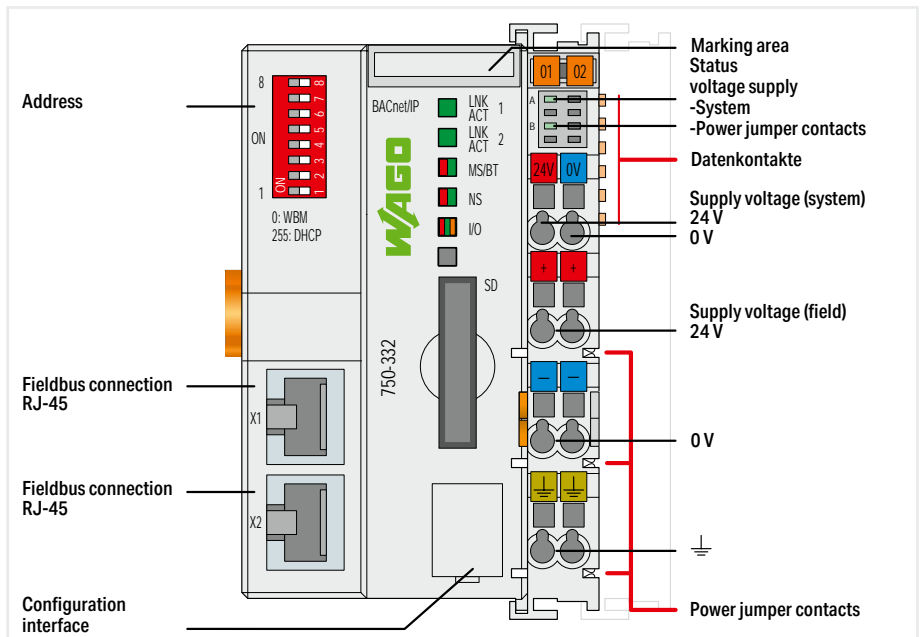

Version
Item no.
Order Text

Standard
750-332
FC BACnet/IP

Technical data
Communication
Protocols
Connection technology: communication/fieldbus
Device-specific
Baud rate
Transmission medium (communication/fieldbus)
Transmission performance
Type of memory card
Number of modules per node (max.)
Input and output process image (fieldbus) max.
Supply voltage (system)
Supply voltage (field)
Input current (typ.) at nominal load (24 V)
Current consumption (5 V system supply)
Total current (system supply)
Ambient temperature (operation)
Dimensions W x H x D
Approvals

BACnet/IP; Modbus (TCP, UDP)
HTTP(S), BootP, DHCP, DNS, (S)FTP, SNMP
BACnet/IP: 2 x RJ-45; Modbus (TCP, UDP): 2 x RJ-45
BACnet device profile: B-BC (BACnet building controller); BACnet revision: 12
10/100 Mbit/s
Twisted pair S-UTP; 100 Ω; Cat. 5; 100 m maximum cable length
Class D per EN 50173
SD and SDHC up to 32 GB (all guaranteed properties only valid with WAGO Memory Card)
250
1020 words/1020 words
24 VDC (-25 ... +30 %); via pluggable connector (CAGE CLAMP® connection)
24 VDC (-25 ... +30 %); via power jumper contacts
500 mA
440 mA
1700 mA
0 ... +55 °C
(61.5 x 100 x 71.9) mm
CE; Marine; OrdLoc/HazLoc; ATEX/IECEX

For data sheet and additional information, see:

wago.com/750-332

Accessories
Memory Card SD; pSLC-NAND; 8 GB; Temperature range: -40 to 90°C

Item no.
758-879/000-2108

7.1

Fieldbus couplers ▶ EtherCAT



750-354

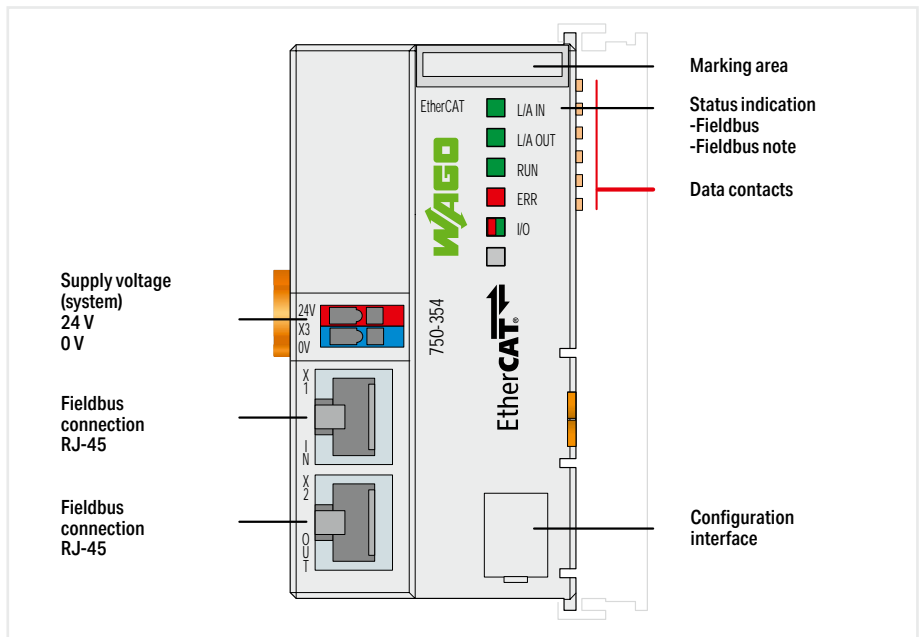

7.1

Version	Standard
Item no.	750-354
Order Text	FC EtherCAT
Technical data	
Communication	EtherCAT®
Protocols	EtherCAT® (direct mode)
Connection technology: communication/fieldbus	EtherCAT: 2 x RJ-45
Baud rate	100 Mbit/s
Transmission medium (communication/fieldbus)	Shielded twisted pair S/FTP, F/FTP or SF/FTP; 100 Ω; Cat. 6
Transmission performance	Class D per EN 50173
Number of modules per node (max.)	64
Input and output process image (fieldbus) max.	1024 bytes/1024 bytes
Supply voltage (system)	24 VDC (-25 ... +30 %); via pluggable connector
Input current (typ.) at nominal load (24 V)	250 mA
Current consumption (5 V system supply)	300 mA
Total current (system supply)	700 mA
Ambient temperature (operation)	0 ... +55 °C
Dimensions W x H x D	(49.5 x 96.8 x 71.9) mm
Approvals	CE, OrdLoc/HazLoc, ATEX/IECEx
For data sheet and additional information, see:	wago.com/750-354

Fieldbus couplers ▶ EtherCAT®; ID switch



750-354/000-001

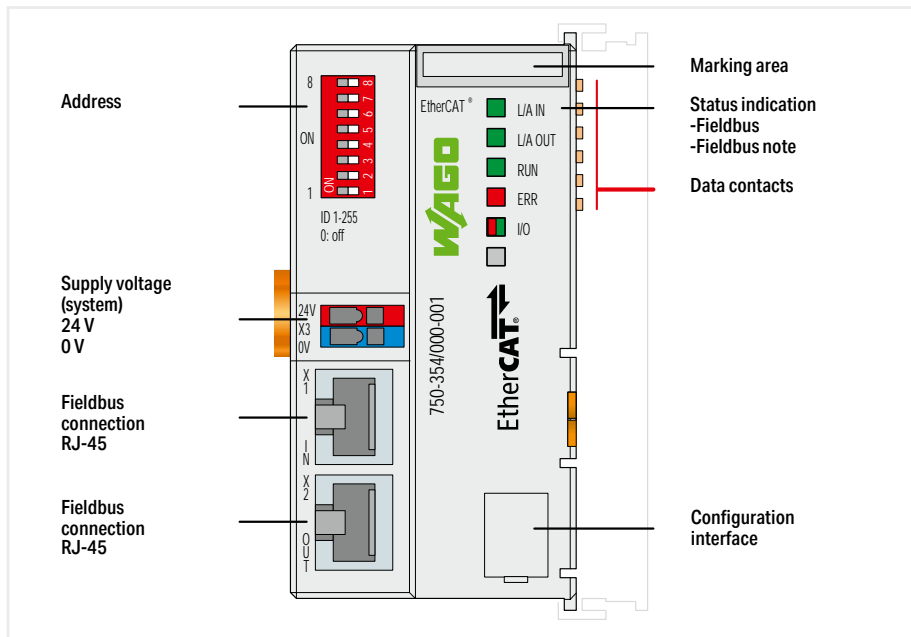

Version	Standard	Diagnostics
Item no.	750-354/000-001	750-354/000-002
Order Text	FC EtherCAT; ID-Switch	FC EtherCAT; ID-Switch; 100Mbit/s; Diagn

Technical data	
Communication	EtherCAT®
Protocols	EtherCAT® (direct mode)
Connection technology: communication/fieldbus	EtherCAT: 2 x RJ-45
Baud rate	100 Mbit/s
Transmission medium (communication/fieldbus)	Shielded twisted pair S/FTP, F/FTP or SF/FTP; 100 Ω; Cat. 6
Transmission performance	Class D per EN 50173
Number of modules per node (max.)	64
Input and output process image (fieldbus) max.	1024 bytes/1024 bytes
Supply voltage (system)	24 VDC (-25 ... +30 %); via pluggable connector
Input current (typ.) at nominal load (24 V)	250 mA
Current consumption (5 V system supply)	300 mA
Total current (system supply)	700 mA
Ambient temperature (operation)	0 ... +55 °C
Dimensions W x H x D	(49.5 x 96.8 x 71.9) mm
Approvals	CE; Marine; OrdLoc/HazLoc; ATEX/IECEX
For data sheet and additional information, see:	wago.com/750-354/000-001

7.1
Fieldbus
Couplers

Fieldbus couplers ► MODBUS; RS-485; 115.2 kBd



750-315/300-000

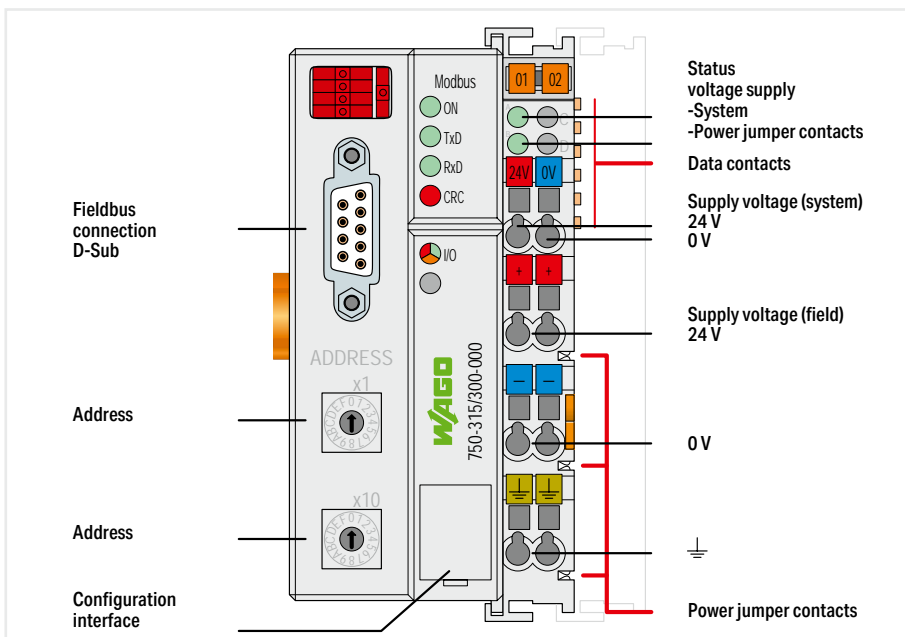

Version
Item no.
Order Text

Standard
750-315/300-000
FC MODBUS; RS485; 115.2kBd

Technical data
Communication
Connection technology: communication/fieldbus
Number of fieldbus nodes on master (max.)
Baud rate
Transmission medium (communication/fieldbus)
Number of modules per node (max.)
Input and output process image (fieldbus) max.
Supply voltage (system)
Supply voltage (field)
Input current (typ.) at nominal load (24 V)
Current consumption (5 V system supply)
Total current (system supply)
Ambient temperature (operation)
Dimensions W x H x D
Approvals
For data sheet and additional information, see:

Modbus® RTU
Modbus® RTU: 1 x D-sub 9 socket
247
150 Bd ... 115.2 kBd
Shielded Cu cable 2 (4) x 0.25 mm²
64
512 bytes/512 bytes
24 VDC (-25 ... +30 %); via pluggable connector (CAGE CLAMP® connection)
24 VDC (-25 ... +30 %); via power jumper contacts
500 mA
350 mA
1650 mA
0 ... +55 °C
(50.5 x 100 x 71.1) mm
CE; Marine; OrdLoc/HazLoc; ATEX/IECEX
wago.com/750-315/300-000

7.1

Fieldbus couplers ► MODBUS; RS-232; 115.2 kBd



750-316/300-000

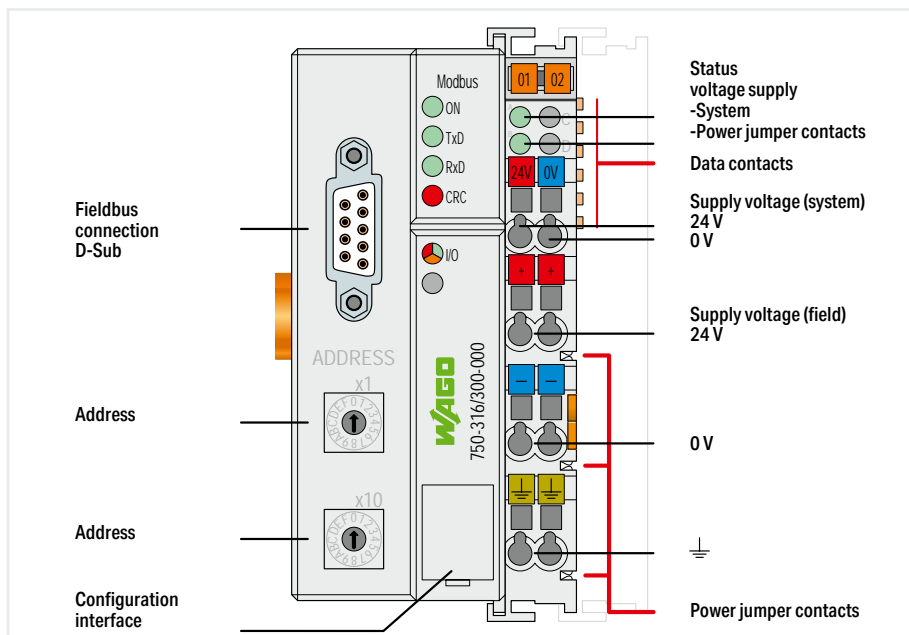

Version
Item no.
Order Text

Standard
750-316/300-000
FC MODBUS; RS232; 115.2kBd

Technical data
Communication
Connection technology: communication/fieldbus
Number of fieldbus nodes on master (max.)
Baud rate
Transmission medium (communication/fieldbus)
Number of modules per node (max.)
Input and output process image (fieldbus) max.
Supply voltage (system)
Supply voltage (field)
Input current (typ.) at nominal load (24 V)
Current consumption (5 V system supply)
Total current (system supply)
Ambient temperature (operation)
Dimensions W x H x D
Approvals
For data sheet and additional information, see:

Modbus® RTU
Modbus® RTU: 1 x D-sub 9 socket
247
150 Bd ... 115.2 kBd
Shielded Cu cable 2 (4) x 0.25 mm ²
64
512 bytes/512 bytes
24 VDC (-25 ... +30 %); via pluggable connector (CAGE CLAMP® connection)
24 VDC (-25 ... +30 %); via power jumper contacts
500 mA
350 mA
1650 mA
0 ... +55 °C
(50.5 x 100 x 71.1) mm
CE; Marine; OrdLoc/HazLoc; ATEX/IECEx
wago.com/750-316/300-000

Fieldbus couplers ▶ DeviceNet



750-306

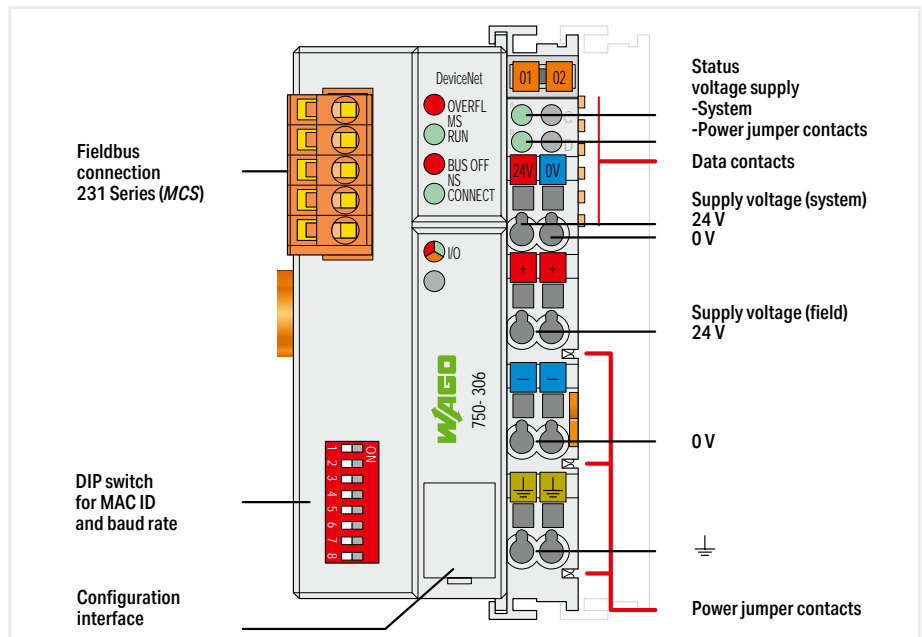

Version	Standard
Item no.	750-306
Order Text	FC DeviceNet

Version	Standard
Item no.	750-306
Order Text	FC DeviceNet

Technical data	DeviceNet
Communication	DeviceNet
Connection technology: communication/fieldbus	DeviceNet: 1 x Male connector; 5-pole
Number of fieldbus nodes on master (max.)	64
Number of I/O points	6000
Bus segment length (max.)	500 m
Baud rate	500 kBd (125 kBd, 250 kBd, 500 kBd)
Transmission medium (communication/fieldbus)	Shielded Cu cable; Remote bus cable: 2 x 0.82 mm ² + 2 x 1.7 mm ² ; Drop cable: 2 x 0.2 mm ² + 2 x 0.32 mm ²
Number of modules per node (max.)	64
Input and output process image (fieldbus) max.	512 bytes/512 bytes
Supply voltage (system)	24 VDC (-25 ... +30 %); via pluggable connector (CAGE CLAMP® connection)
Supply voltage (field)	24 VDC (-25 ... +30 %); via power jumper contacts
Input current (typ.) at nominal load (24 V)	500 mA
Input current via DeviceNet interface at 11 V	120 mA
Current consumption (5 V system supply)	350 mA
Total current (system supply)	1650 mA
Ambient temperature (operation)	0 ... +55 °C
Dimensions W x H x D	(50.5 x 100 x 71.1) mm
Approvals	CE; Marine; OrdLoc/HazLoc; ATEX/IECEX

For data sheet and additional information, see:

wago.com/750-306

Fieldbus couplers ▶ DeviceNet; ECO



750-346

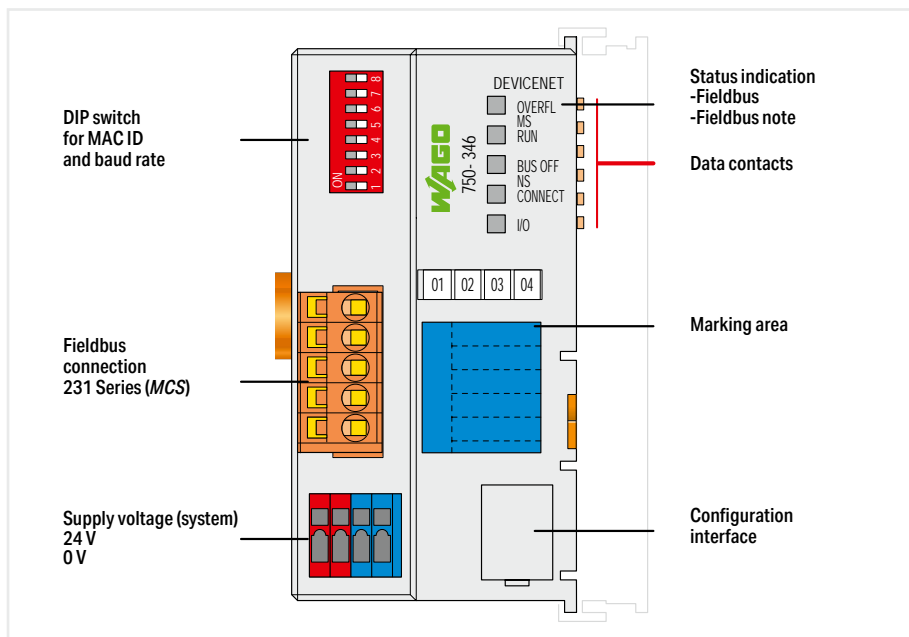

Version
Item no.
Order Text

Standard
750-346
FC DeviceNet; ECO

Technical data
Communication
Connection technology: communication/fieldbus
Number of fieldbus nodes on master (max.)
Number of I/O points
Bus segment length (max.)
Baud rate
Transmission medium (communication/fieldbus)
Number of modules per node (max.)
Input and output process image (fieldbus) max.
Supply voltage (system)
Input current (typ.) at nominal load (24 V)
Input current via DeviceNet interface at 11 V
Current consumption (5 V system supply)
Total current (system supply)
Ambient temperature (operation)
Dimensions W x H x D
Approvals
For data sheet and additional information, see:

DeviceNet
DeviceNet: 1 x Male connector; 5-pole
64
6000
500 m
500 kBd (125 kBd, 250 kBd, 500 kBd)
Shielded Cu cable; Remote bus cable: 2 x 0.82 mm ² + 2 x 1.7 mm ² ; Drop cable: 2 x 0.2 mm ² + 2 x 0.32 mm ²
64
32 bytes/32 bytes
24 VDC (-15 ... +20 %); via pluggable connector
260 mA
120 mA
350 mA
650 mA
0 ... +55 °C
(49.5 x 96.8 x 71.9) mm
CE; OrdLoc; ATEX/IECEx
wago.com/750-346

Fieldbus couplers ▶ CANopen; MCS



750-337

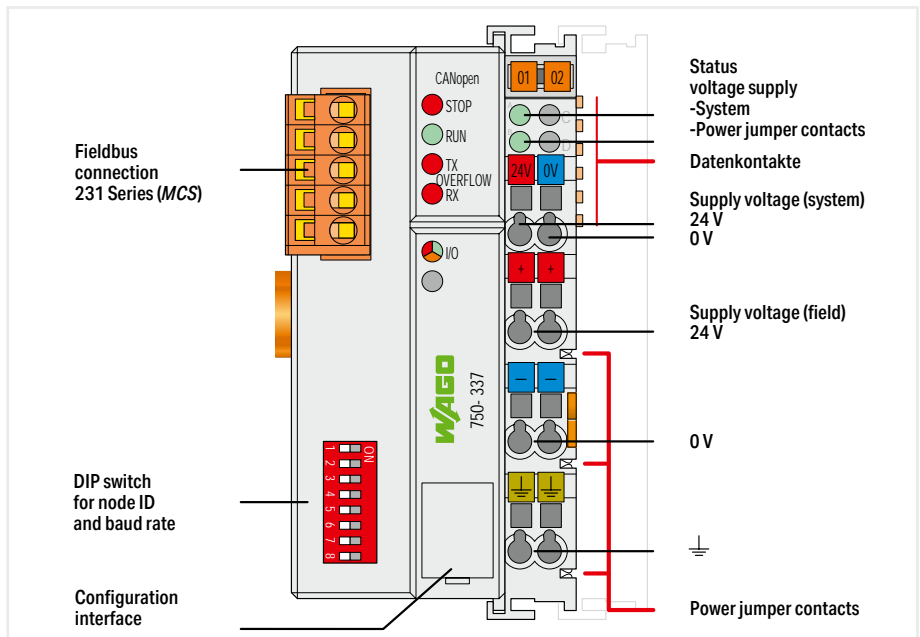

Version	Standard	ext. temperature
Item no.	750-337	750-337/025-000
Order Text	FC CANopen; MCS	FC CANopen; MCS; T

Technical data		
Communication	CANopen	
Connection technology: communication/fieldbus	CANopen: 1 x Male connector; 5-pole	
Number of fieldbus nodes on master (max.)	110	
Bus segment length (max.)	1000 m	
Baud rate	10 kBd ... 1 MBd	
Transmission medium (communication/fieldbus)	Shielded Cu cable 3 x 0.25 mm ²	
Number of modules per node (max.)	64	
Input and output process image (fieldbus) max.	512 bytes/512 bytes	
Number of PDOs	32 Tx / 32 Rx	
Number of SDOs	2 SDO servers	
Communication profile	DS-301 V4.1	
Device profile	DS-401 V2.0; Limit value monitoring ; Edge-triggered PDOs; Configurable response in the event of an error	
Supply voltage (system)	24 VDC (-25 ... +30 %); via pluggable connector (CAGE CLAMP® connection)	
Supply voltage (field)	24 VDC (-25 ... +30 %); via power jumper contacts	
Input current (typ.) at nominal load (24 V)	500 mA	
Current consumption (5 V system supply)	350 mA	
Total current (system supply)	1650 mA	
Ambient temperature (operation)	0 ... +55 °C	-20 ... +60 °C
Dimensions W x H x D	(50.5 x 100 x 71.1) mm	
Approvals	CE; Marine; OrdLoc/HazLoc; ATEX/IECEX	

For data sheet and additional information, see:

wago.com/750-337

Fieldbus couplers ▶ CANopen; D-Sub



750-338

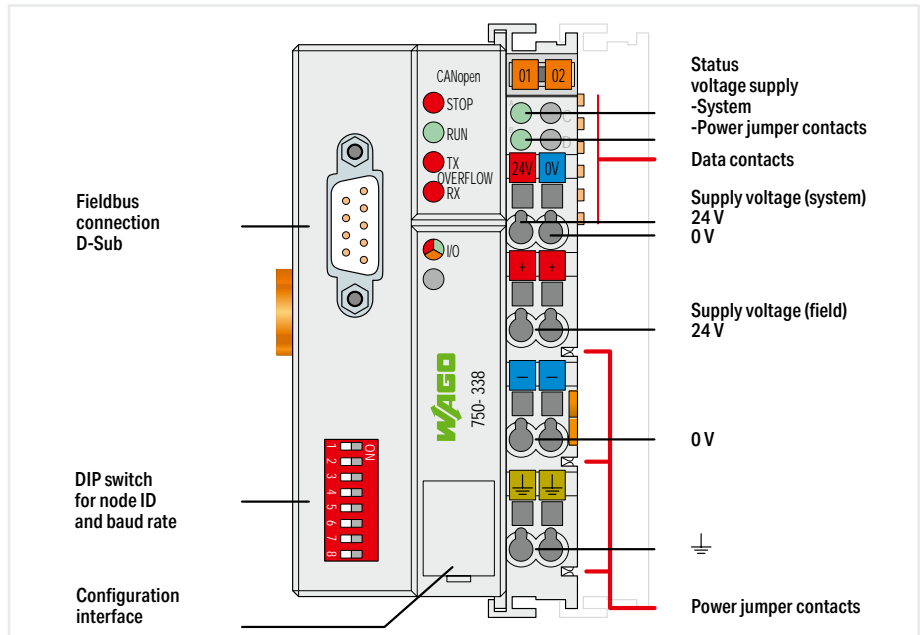

Version
Item no.
Order Text

Standard
750-338
FC CANopen; DSub

Technical data
Communication
Connection technology: communication/fieldbus
Number of fieldbus nodes on master (max.)
Bus segment length (max.)
Baud rate
Transmission medium (communication/fieldbus)
Number of modules per node (max.)
Input and output process image (fieldbus) max.
Number of PDOs
Number of SDOs
Communication profile
Device profile
Supply voltage (system)
Supply voltage (field)
Input current (typ.) at nominal load (24 V)
Current consumption (5 V system supply)
Total current (system supply)
Ambient temperature (operation)
Dimensions W x H x D
Approvals

CANopen
CANopen: 1 x D-sub 9 plug
110
1000 m
10 kBd ... 1 MBd
Shielded Cu cable 3 x 0.25 mm ²
64
512 bytes/512 bytes
32 Tx / 32 Rx
2 SDO servers
DS-301 V4.1
DS-401 V2.0; Limit value monitoring ; Edge-triggered PDOs; Configurable response in the event of an error
24 VDC (-25 ... +30 %); via pluggable connector (CAGE CLAMP® connection)
24 VDC (-25 ... +30 %); via power jumper contacts
500 mA
350 mA
1650 mA
0 ... +55 °C
(50.5 x 100 x 71.1) mm
CE; Marine; OrdLoc/HazLoc; ATEX/IECEX

For data sheet and additional information, see:

wago.com/750-338

Fieldbus couplers ▶ CANopen; MCS; ECO

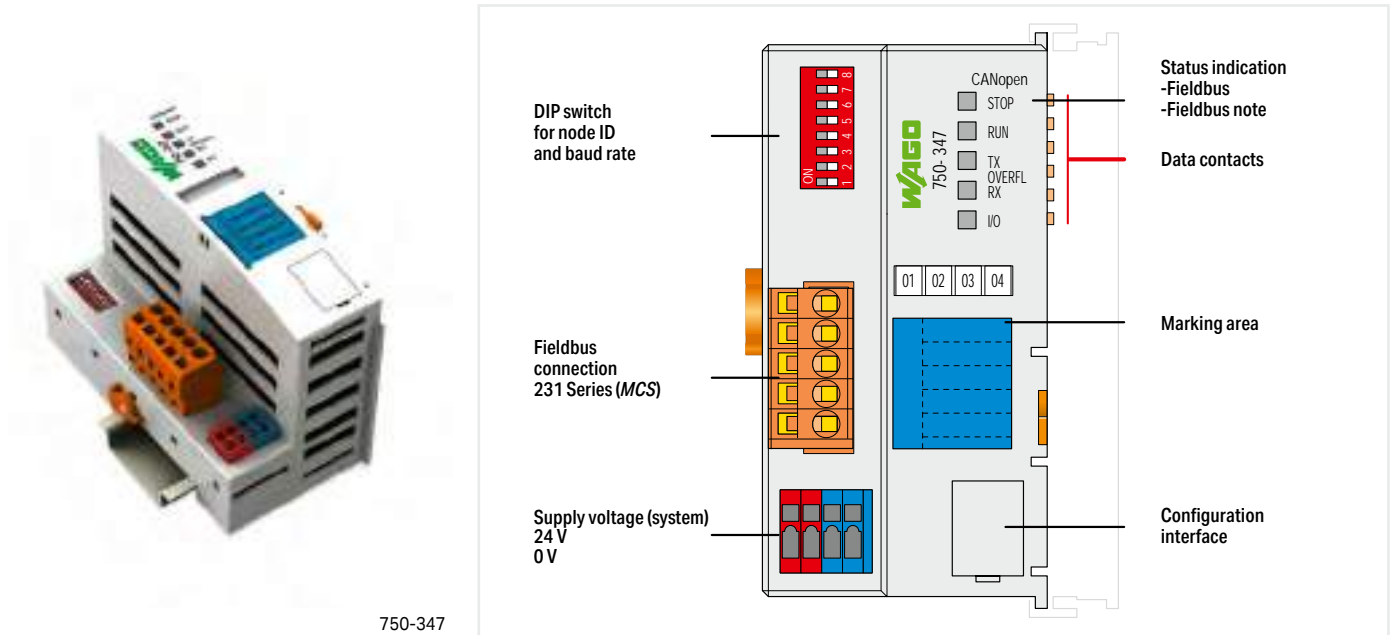

750-347

7.1

Version	Standard
Item no.	750-347
Order Text	FC CANopen; MCS; ECO
Technical data	
Communication	CANopen
Connection technology: communication/fieldbus	CANopen: 1 x Male connector; 5-pole
Number of fieldbus nodes on master (max.)	110
Bus segment length (max.)	1000 m
Baud rate	10 kBd ... 1 MBd
Transmission medium (communication/fieldbus)	Shielded Cu cable 3 x 0.25 mm ²
Number of modules per node (max.)	64
Input and output process image (fieldbus) max.	32 bytes/32 bytes
Number of PDOs	5 Tx / 5 Rx
Number of SDOs	1 SDO server
Communication profile	DS-301 V4.1
Device profile	DS-401 V2.0; Configurable response in the event of an error
Supply voltage (system)	24 VDC (-25 ... +30 %); via pluggable connector
Input current (typ.) at nominal load (24 V)	260 mA
Current consumption (5 V system supply)	350 mA
Total current (system supply)	650 mA
Ambient temperature (operation)	0 ... +55 °C
Dimensions W x H x D	(49.5 x 96.8 x 71.9) mm
Approvals	CE; Marine; OrdLoc/HazLoc; ATEX/IECEx
For data sheet and additional information, see:	wago.com/750-347

Fieldbus couplers ▶ CANopen; D-Sub; ECO



750-348

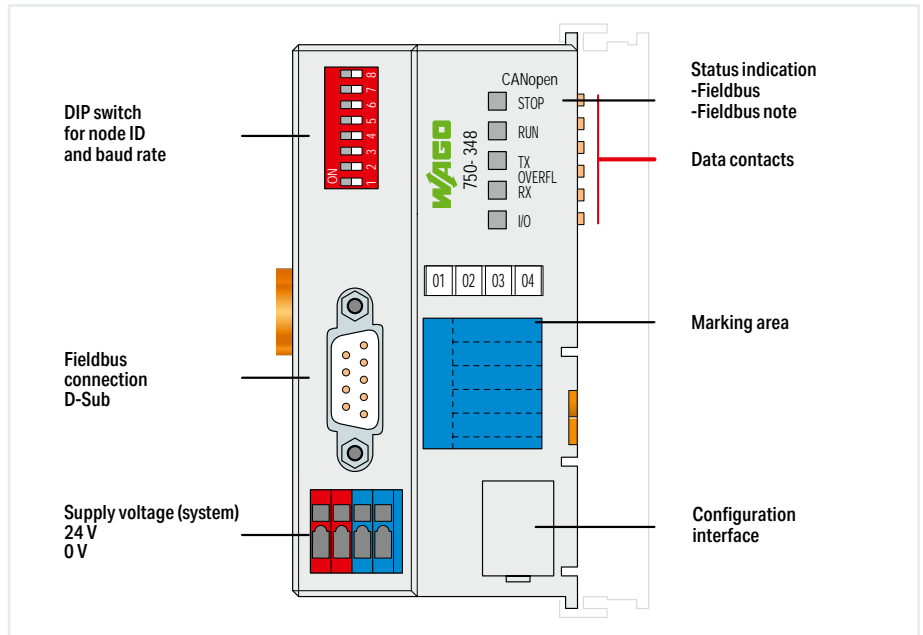

Version	Standard
Item no.	750-348
Order Text	FC CANopen; DSub; ECO
Technical data	
Communication	CANopen
Connection technology: communication/fieldbus	CANopen: 1 x D-sub 9 plug
Number of fieldbus nodes on master (max.)	110
Bus segment length (max.)	1000 m
Baud rate	10 kBd ... 1 MBd
Transmission medium (communication/fieldbus)	Shielded Cu cable 3 x 0.25 mm ²
Number of modules per node (max.)	64
Input and output process image (fieldbus) max.	32 bytes/32 bytes
Number of PDOs	5 Tx / 5 Rx
Number of SDOs	1 SDO server
Communication profile	DS-301 V4.1
Device profile	DS-401 V2.0; Configurable response in the event of an error
Supply voltage (system)	24 VDC (-25 ... +30 %); via pluggable connector
Input current (typ.) at nominal load (24 V)	260 mA
Current consumption (5 V system supply)	350 mA
Total current (system supply)	650 mA
Ambient temperature (operation)	0 ... +55 °C
Dimensions W x H x D	(49.5 x 96.8 x 71.9) mm
Approvals	CE; L; Marine; OrdLoc/HazLoc; ATEX/IECEX
For data sheet and additional information, see:	wago.com/750-348

Fieldbus couplers ► INTERBUS



750-304

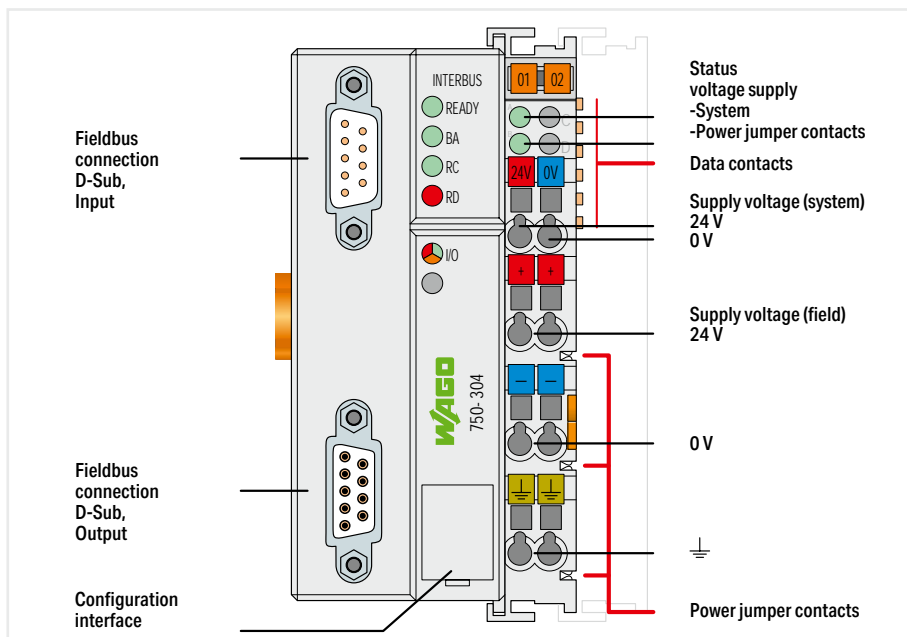

Version
Item no.
Order Text

Standard
750-304
FC INTERBUS

Technical data
Communication
Connection technology: communication/fieldbus
Number of fieldbus nodes on master (max.)
Number of I/O points
Bus segment length (max.)
Baud rate
Transmission medium (communication/fieldbus)
Number of modules per node (max.)
Input and output process image (fieldbus) max.
Supply voltage (system)
Supply voltage (field)
Input current (typ.) at nominal load (24 V)
Current consumption (5 V system supply)
Total current (system supply)
Ambient temperature (operation)
Dimensions W x H x D
Approvals
For data sheet and additional information, see:

INTERBUS
INTERBUS: 1 x D-sub 9 plug/socket
256
4096
400 m
500 kBd
Certified Cu cable
64
64 bytes/64 bytes
24 VDC (-15 ... +20 %); via pluggable connector (CAGE CLAMP® connection)
24 VDC (-15 ... +20 %); via power jumper contacts
500 mA
300 mA
1700 mA
0 ... +55 °C
(50.5 x 100 x 71.1) mm
CE; OrdLoc/HazLoc; ATEX/IECEx
wago.com/750-304

7.1

Fieldbus couplers ► INTERBUS; ECO

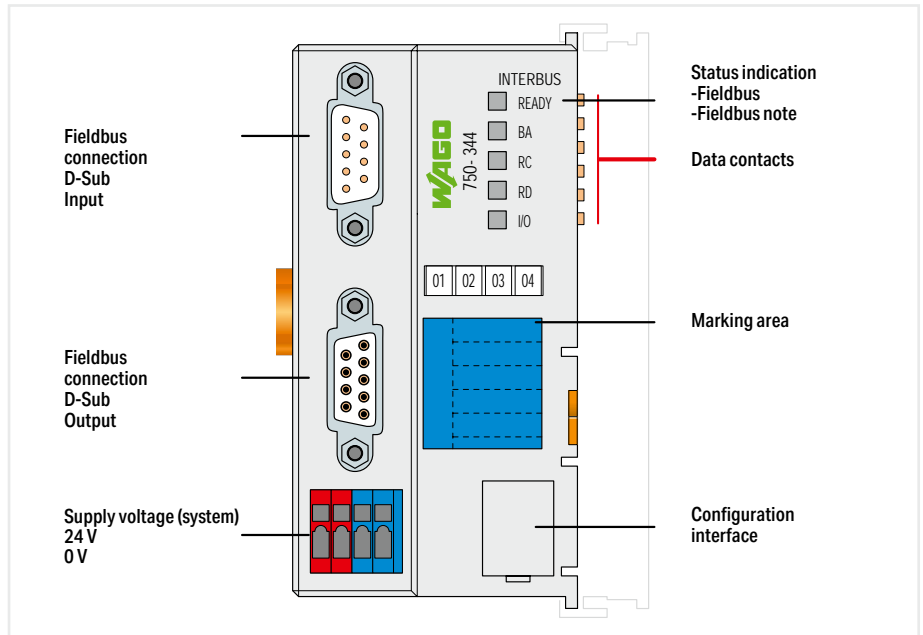

750-344

Version	Standard
Item no.	750-344
Order Text	FC INTERBUS; 500kbit/s; ECO

Technical data	
Communication	INTERBUS
Connection technology: communication/fieldbus	INTERBUS: 1 x D-sub 9 plug/socket
Number of fieldbus nodes on master (max.)	256
Number of I/O points	4096
Bus segment length (max.)	400 m
Baud rate	500 kBd
Transmission medium (communication/fieldbus)	Certified Cu cable
Number of modules per node (max.)	64
Input and output process image (fieldbus) max.	20 bytes/20 bytes
Supply voltage (system)	24 VDC (-15 ... +20 %); via pluggable connector
Input current (typ.) at nominal load (24 V)	260 mA
Current consumption (5 V system supply)	350 mA
Total current (system supply)	650 mA
Ambient temperature (operation)	0 ... +55 °C
Dimensions W x H x D	(49.5 x 96.8 x 71.9) mm
Approvals	CE, OrdLoc/HazLoc, ATEX/IECEx
For data sheet and additional information, see:	wago.com/750-344

Fieldbus couplers ► CC-Link; D-Sub



750-310

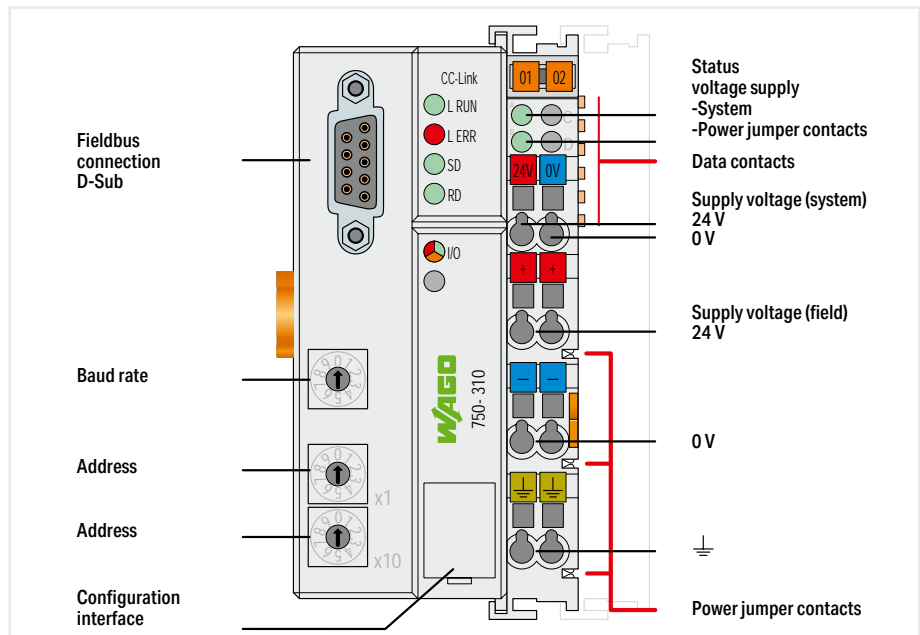

Version	Standard
Item no.	750-310
Order Text	FC CC-Link

Technical data	
Communication	CC-Link
Connection technology: communication/fieldbus	CC-Link: 1 x D-sub 9 socket
Number of fieldbus nodes on master (max.)	64
Baud rate	156 kBd ... 10 MBd
Transmission medium (communication/fieldbus)	Shielded Cu cable 2 / 3 x 0.5 mm ²
Number of modules per node (max.)	64
Station addresses	4/1 ... 4
Input and output process image (fieldbus) max.	48 bytes/48 bytes
Input process image (note)	14-byte digital, 2-byte system, 32-byte analog
Output process image (note)	14-byte digital, 2-byte system, 32-byte analog
Supply voltage (system)	24 VDC (-25 ... +30 %); via pluggable connector (CAGE CLAMP® connection)
Supply voltage (field)	24 VDC (-25 ... +30 %); via power jumper contacts
Input current (typ.) at nominal load (24 V)	500 mA
Current consumption (5 V system supply)	300 mA
Total current (system supply)	1700 mA
Ambient temperature (operation)	0 ... +55 °C
Dimensions W x H x D	(50.5 x 100 x 71.1) mm
Approvals	CE; OrdLoc/HazLoc; ATEX/IECEx

For data sheet and additional information, see:

wago.com/750-310

Fieldbus couplers ► CC-Link; MCS



750-325

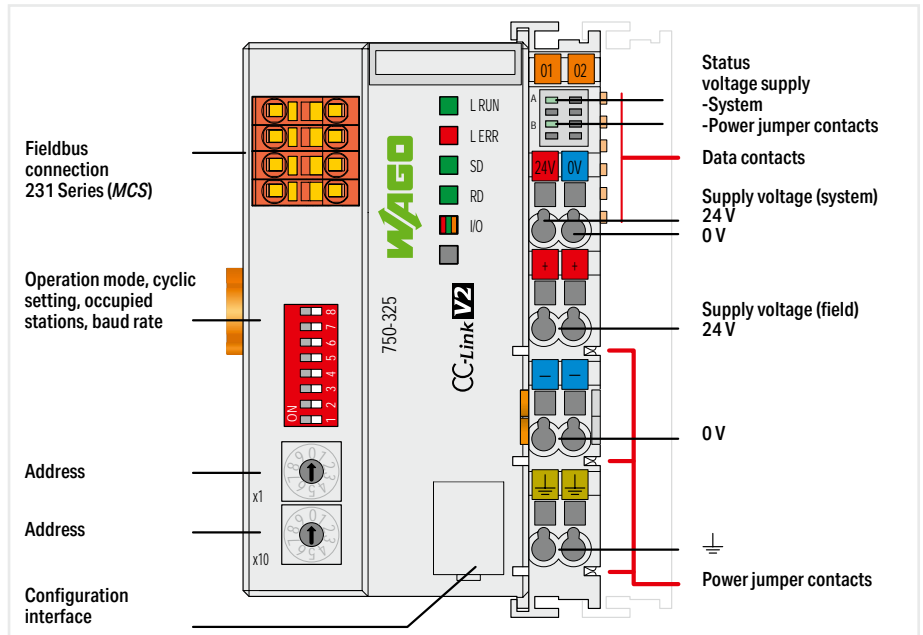

Version
Item no.
Order Text

Standard
750-325
FC CC-Link

Technical data
Communication
Connection technology: communication/fieldbus
Device-specific
Number of fieldbus nodes on master (max.)
Baud rate
Transmission medium (communication/fieldbus)
Number of modules per node (max.)
Station addresses
Input process image (note)
Output process image (note)
Supply voltage (system)
Supply voltage (field)
Input current (typ.) at nominal load (24 V)
Current consumption (5 V system supply)
Total current (system supply)
Ambient temperature (operation)
Dimensions W x H x D
Approvals

CC-Link
CC-Link: 1 x Male connector; 4-pole
Operating mode: CC-Link V2.0 (default setting)/V1.1; Advanced cycle setting: 1, 2, 4 (default setting), 8 cycles
64
156 kBd ... 10 MBd
Shielded Cu cable 2 / 3 x 0.5 mm ²
64
1 ... 4 / 4 (default setting)
RX (digital inputs): V1.1: 16, 48, 80, 112 bits; V2.0: 16, 48, 80, 112 bits (1 cycle); V2.0: 16, 80, 144, 208 bits (2 cycles); V2.0: 48, 176, 304, 432 bits (4 cycles); V2.0: 112, 368, 624, 880 bits (8 cycles) and 16 bits per system area; RWr (analog inputs): V1.1: 4, 8, 12, 16 words (16 bits); V2.0: 4, 8, 12, 16 words (1 cycle); V2.0: 8, 16, 24, 32 words (2 cycles); V2.0: 16, 32, 48, 64 words (4 cycles); V2.0: 32, 64, 96, 128 words (8 cycles)
RY (digital outputs): V1.1: 16, 48, 80, 112 bits; V2.0: 16, 48, 80, 112 bits (1 cycle); V2.0: 16, 80, 144, 208 bits (2 cycles); V2.0: 48, 176, 304, 432 bits (4 cycles); V2.0: 112, 368, 624, 880 bits (8 cycles) and 16 bits per system area; RWw (analog outputs): V1.1: 4, 8, 12, 16 words (16 bits); V2.0: 4, 8, 12, 16 words (1 cycle); V2.0: 8, 16, 24, 32 words (2 cycles); V2.0: 16, 32, 48, 64 words (4 cycles); V2.0: 32, 64, 96, 128 words (8 cycles)
24 VDC (-25 ... +30 %); via pluggable connector (CAGE CLAMP® connection)
24 VDC (-25 ... +30 %); via power jumper contacts
600 mA
200 mA
1800 mA
0 ... +55 °C
(61.5 x 100 x 71.9) mm
CE, OrdLoc/HazLoc, ATEX/IECEx

For data sheet and additional information, see:

wago.com/750-325

Digital Input Modules



Housing Design (750 Series)

Dimensions W x H x D	Housing with 4 LEDs: 12 x 100 x 69.8 mm Housing with 8 LEDs: 12 x 100 x 67.8 mm
Depth from upper edge of DIN-rail	Housing with 4 LEDs: 62.6 mm Housing with 8 LEDs: 60.6 mm
Connection technology	CAGE CLAMP®
Conductor cross-section	0.08 ... 2.5 mm ² / 28 ... 14 AWG
Strip length	8 ... 9 mm / 0.33 inch

Housing Design (753 Series)

Dimensions W x H x D	Housing with 4 LEDs: 12 x 100 x 69.8 mm Housing with 8 LEDs: 12 x 100 x 69 mm
Depth from upper edge of DIN-rail	Housing with 4 LEDs: 62.6 mm Housing with 8 LEDs: 61.8 mm
Connection technology	CAGE CLAMP®
Conductor cross-section	0.08 ... 2.5 mm ² / 28 ... 14 AWG
Strip length	9 ... 10 mm / 0.37 inch

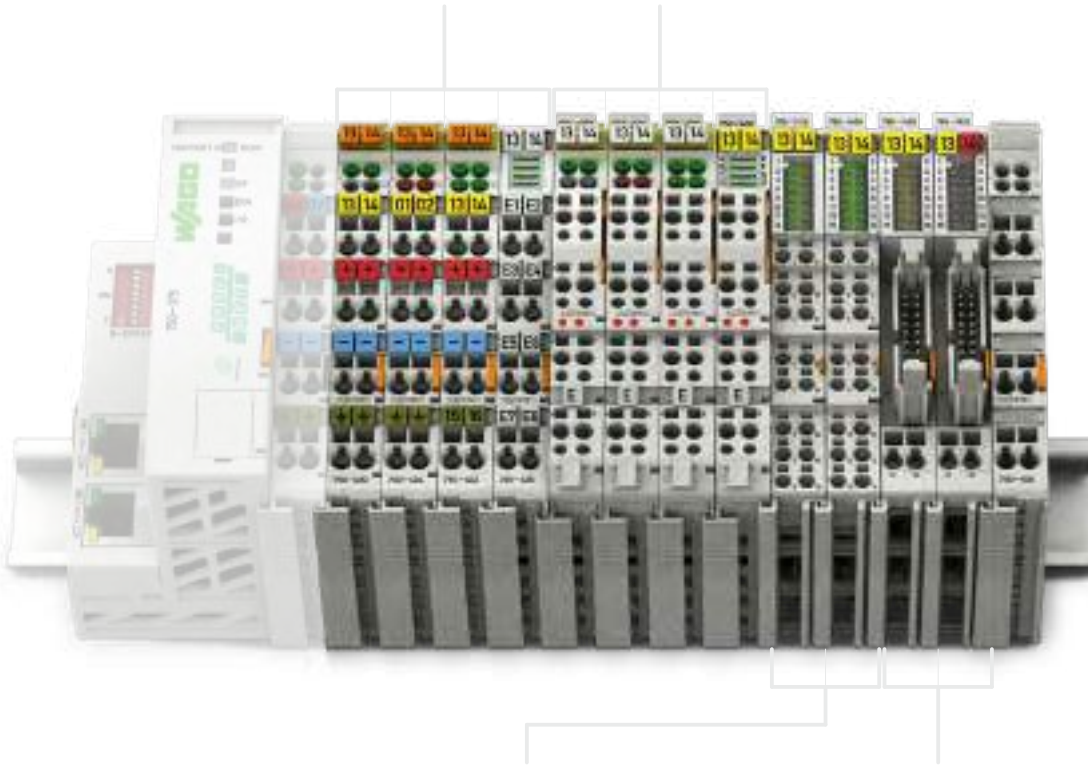

Housing Design (750 Series), with Push-in CAGE CLAMP® Connections (up to 16 connection points)

Dimensions W x H x D	12 x 100 x 69 mm
Depth from upper edge of DIN-rail	61.8 mm
Connection technology	Push-in CAGE CLAMP®
Conductor cross-section	Solid: 0.08 ... 1.5 mm ² / 28 ... 16 AWG Fine-stranded: 0.25 ... 1.5 mm ² / 22 ... 16 AWG
Strip length	8 ... 9 mm / 0.33 inch

Housing Design (750 Series), with Ribbon Cable Connection

Dimensions W x H x D	12 x 100 x 74.1 mm
Depth from upper edge of DIN-rail	66.9 mm
Connection technology	20-pole male connector + 2 x CAGE CLAMP®
Conductor cross-section	0.08 ... 2.5 mm ² / 28 ... 14 AWG
Strip length	8 ... 9 mm / 0.33 inch



I/O System –
750 XTR Series



I/O System – 750 and 753 Series, Digital Input Modules

Contents

Function	2-Channel DI	4-Channel DI	8-Channel DI	16-Channel DI	8-Channel DIO	Description	Item Number			Page		
							Standard	Extended Temperature	Pluggable			
5 VDC		<input type="checkbox"/>				4-Channel Digital Input; 5 VDC; 0.2 ms	750-414			230		
5/12 VDC			<input type="checkbox"/>			8-Channel Digital Input; 5/12 VDC; 0.2 ms				753-434	231	
24 VDC	<input type="checkbox"/>					2-Channel Digital Input; 24 VDC; 3 ms; Acknowledgment; Diagnostics	750-418			753-418	232	
	<input type="checkbox"/>					2-Channel Digital Input; 24 VDC; 3 ms; Diagnostics	750-421			753-421	232	
	<input type="checkbox"/>					2-Channel Digital Input; 24 VDC; 3 ms	750-400	750-400/025-000		753-400	233	
	<input type="checkbox"/>					4-Channel Digital Input; 24 VDC; 3 ms	750-402	750-402/025-000		753-402	234	
	<input type="checkbox"/>					4-Channel Digital Input; 24 VDC; 3 ms; 2-Wire Connection	750-432			753-432	235	
	<input type="checkbox"/>					4-Channel Digital Input; 24 VDC; 3 ms; 3-Wire Connection	750-1420				236	
				<input type="checkbox"/>		8-Channel Digital Input; 24 VDC; 3 ms	750-430*	750-430/025-000		753-430	237	
				<input type="checkbox"/>		8-Channel Digital Input; 24 VDC; 3 ms; 2-Wire Connection	750-1415*				238	
					<input type="checkbox"/>	16-Channel Digital Input; 24 VDC; 3 ms	750-1405*				239	
					<input type="checkbox"/>	16-Channel Digital Input; 24 VDC; 3 ms; Ribbon Cable	750-1400				240	
					<input type="checkbox"/>	8-Channel Digital Input/Output; 24 VDC; 0.5 A	750-1506				241	
					<input type="checkbox"/>	8-Channel Digital Input/Output; 24 VDC; 0.5 A; Ribbon Cable	750-1502				242	
	0.2 ms; High-Side Switching	<input type="checkbox"/>					2-Channel Digital Input; 24 VDC; 0.2 ms	750-401			753-401	243
			<input type="checkbox"/>				4-Channel Digital Input; 24 VDC; 0.2 ms	750-403			753-403	244
		<input type="checkbox"/>				4-Channel Digital Input; 24 VDC; 0.2 ms; 2-Wire Connection	750-433			753-433	245	
		<input type="checkbox"/>				4-Channel Digital Input; 24 VDC; 0.2 ms; 3-Wire Connection	750-1421				246	
			<input type="checkbox"/>			8-Channel Digital Input; 24 VDC; 0.2 ms	750-431*			753-431	247	
			<input type="checkbox"/>			8-Channel Digital Input; 24 VDC; 0.2 ms; 2-Wire Connection	750-1416*				248	
3 ms; Low-Side Switching				<input type="checkbox"/>		16-Channel Digital Input; 24 VDC; 0.2 ms	750-1406				249	
		<input type="checkbox"/>				4-Channel Digital Input; 24 VDC; 3 ms; Low-Side Switching	750-408	750-408/025-000		753-408	250	
		<input type="checkbox"/>				4-Channel Digital Input; 24 VDC; 3 ms; Low-Side Switching; 3-Wire Connection	750-1422				251	
			<input type="checkbox"/>			8-Channel Digital Input; 24 VDC; 3 ms; Low-Side Switching	750-436			753-436	252	
			<input type="checkbox"/>			8-Channel Digital Input; 24 VDC; 3 ms; Low-Side Switching; 2-Wire Connection	750-1417*				253	
0.2 ms; Low-Side Switching				<input type="checkbox"/>		16-Channel Digital Input; 24 VDC; 3 ms; Low-Side Switching	750-1407				254	
				<input type="checkbox"/>		16-Channel Digital Input; 24 VDC; 3 ms; Low-Side Switching; Ribbon Cable	750-1402				255	
		<input type="checkbox"/>				4-Channel Digital Input; 24 VDC; 0.2 ms; Low-Side Switching	750-409			753-409	256	
		<input type="checkbox"/>				4-Channel Digital Input; 24 VDC; 0.2 ms; Low-Side Switching; 3-Wire Connection	750-1423				257	
			<input type="checkbox"/>			8-Channel Digital Input; 24 VDC; 0.2 ms; Low-Side Switching	750-437			753-437	258	
		<input type="checkbox"/>			8-Channel Digital Input; 24 VDC; 0.2 ms; Low-Side Switching; 2-Wire Connection	750-1418				259		
24 VAC/DC	<input type="checkbox"/>					2-Channel Digital Input; 24 VDC; 3 ms; Proximity Sensor	750-410			753-410	260	
	<input type="checkbox"/>					2-Channel Digital Input; 24 VDC; 0.2 ms; Proximity Sensor	750-411			753-411	261	
	<input type="checkbox"/>					2-Channel Digital Input; NAMUR	750-425			753-425	262	
	<input type="checkbox"/>					2-Channel Digital Input; Intruder Detection	750-424			753-424	263	
		<input type="checkbox"/>				4-Channel Digital Input; 24 VDC; Pulse Extension	750-422			753-422	264	
		<input type="checkbox"/>				4-Channel Digital Input; 24 VAC/DC; 50 ms	750-423			753-423	265	
		<input type="checkbox"/>				4-Channel Digital Input; 24 VAC/DC; 20 ms	750-415			753-415	266	
	42 VAC/DC		<input type="checkbox"/>			4-Channel Digital Input; 24 VAC/DC; 20 ms	750-428			753-428	267	
	48 VDC	<input type="checkbox"/>				2-Channel Digital Input; 48 VDC; 3 ms	750-412			753-412	268	
	60 VDC	<input type="checkbox"/>				2-Channel Digital Input; 60 VDC; 3 ms	*			753-429	269	
110 VDC	<input type="checkbox"/>				2-Channel Digital Input; 110 VDC; High-Side/Low-Side Switching	750-427*			753-427	270		
220 VDC	<input type="checkbox"/>				2-Channel Digital Input; 220 VDC	750-407*				271		
120 VAC	<input type="checkbox"/>				2-Channel Digital Input; 120 VAC	750-406			753-406	272		
230 VAC	<input type="checkbox"/>				2-Channel Digital Input; 230 VAC	750-405			753-405	273		
120/230 VAC		<input type="checkbox"/>			4-Channel Digital Input; 120/230 VAC				753-440	274		
PTC			<input type="checkbox"/>		8-Channel Digital Input; PTC	750-1425				275		
Functional Safety							See Section 7.8					
Ex i							See Section 7.9					
*This module is also available as a variant of the 750 XTR Series.							See Section 8					

Digital input ▶ 5 VDC ▶ high-side switching ▶ 0.2 ms



750-414

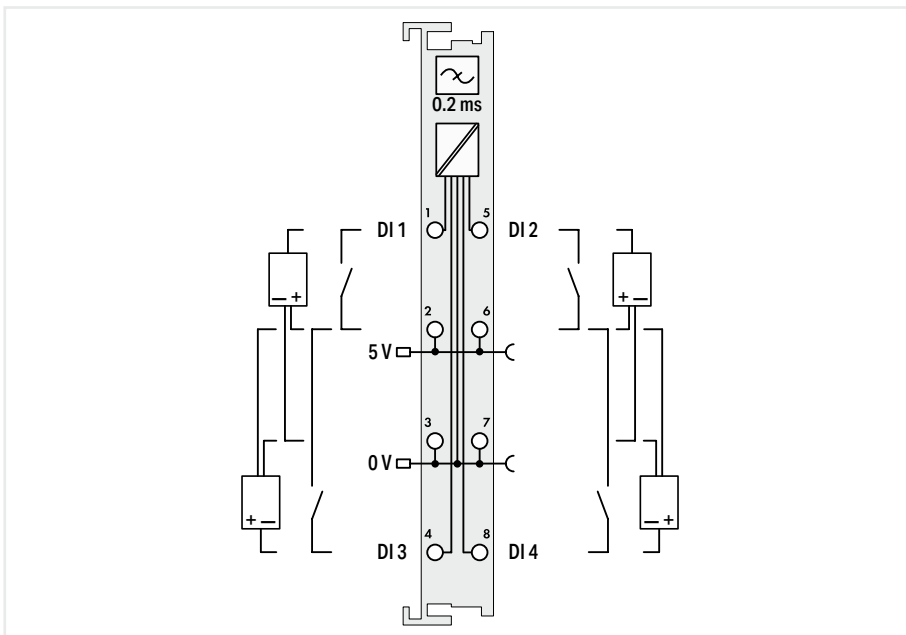

Item description	4-Channel Digital Input; 5 VDC; 0.2 ms
Version	Standard
Item no.	750-414
Order Text	4DI; 5 VDC; 0.2ms

Technical data

Pluggable connector	fixed
Number of digital inputs	4
Signal type	Digital
Signal type (voltage)	5 VDC
Voltage range for signal (0)	0 ... 0.8 VDC
Voltage range for signal (1)	2.4 ... 5 VDC
Sensor connection	2 x (2-wire, 3-wire); A suitable field side connection module (e.g., 750-614) must also be used to connect other sensors.
Input characteristic	high-side switching
Input filter (digital)	0.2 ms
Input current per channel for signal (1) typ.	0.05 mA
Supply voltage (sensor)	5 VDC
Supply voltage (field)	5 VDC; via power jumper contacts (power supply via blade contact; transmission via spring contact)
Current consumption (5 V system supply)	5 mA
Input data width (internal) max.	4 bits
Isolation	500 V system/field
Ambient temperature (operation)	0 ... +55 °C
Dimensions W x H x D	(12 x 100 x 69.8) mm
Approvals	CE, UL, OrdLoc/HazLoc
For data sheet and additional information, see:	wago.com/750-414

Notice: An additional supply module must be added for 5 VDC supply!

Digital input ► 5 VDC ► high-side switching ► 0.2 ms



753-434

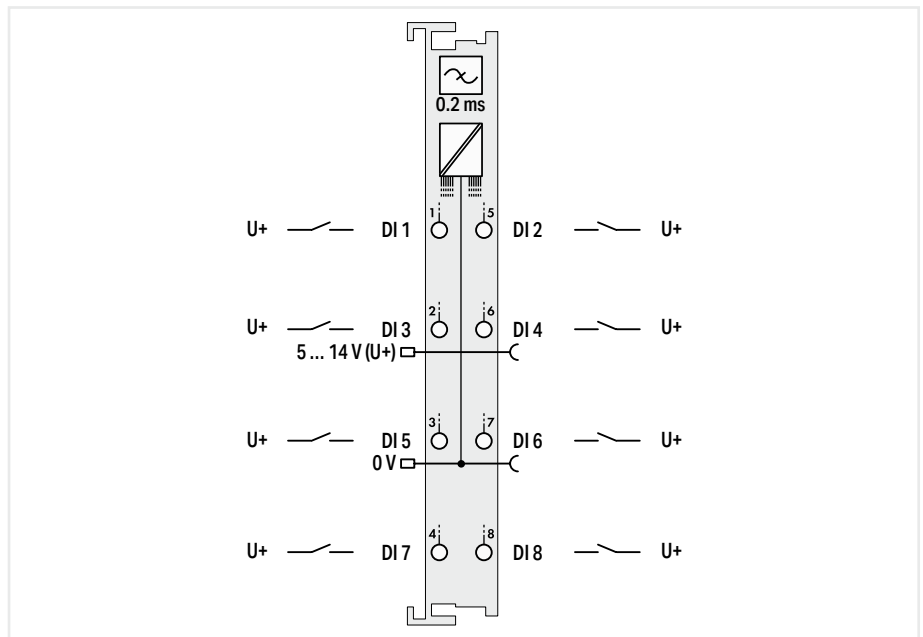

Item description	8-Channel Digital Input; 5/12 VDC; 0.2 ms
Version	pluggable (delivery without connector)
Item no.	753-434
Order Text	8DI; 5/12 VDC; 0.2ms
Technical data	
Pluggable connector	pluggable
Number of digital inputs	8
Signal type	Digital
Signal type (voltage)	5 VDC; 12 VDC
Voltage range for signal (0)	-3 ... 0.2 x U _v DC
Voltage range for signal (1)	0.5 x U _v ... 1.1 x U _v DC
Sensor connection	8 x (1-wire)
Input characteristic	high-side switching
Input filter (digital)	0.2 ms
Input current at specific input voltage	0.06 mA at 12 V
Supply voltage (field)	14 VDC; via power jumper contacts (power supply via blade contact; transmission via spring contact)
Current consumption (5 V system supply)	4 mA
Input data width (internal) max.	8 bits
Isolation	500 V system/field
Ambient temperature (operation)	0 ... +55 °C
Dimensions W x H x D	(12 x 100 x 69) mm
Approvals	CE; Marine; OrdLoc/HazLoc; ATEX/IECEX
For data sheet and additional information, see:	wago.com/753-434
Accessories	Item no.
Plug	753-110

Notice: An additional supply module must be added for 5–14 VDC supply!

Digital input ▶ 24 VDC ▶ high-side switching ▶ 3 ms



750-418

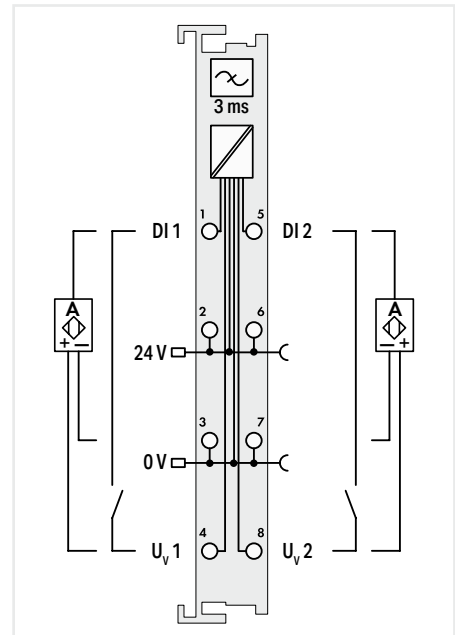
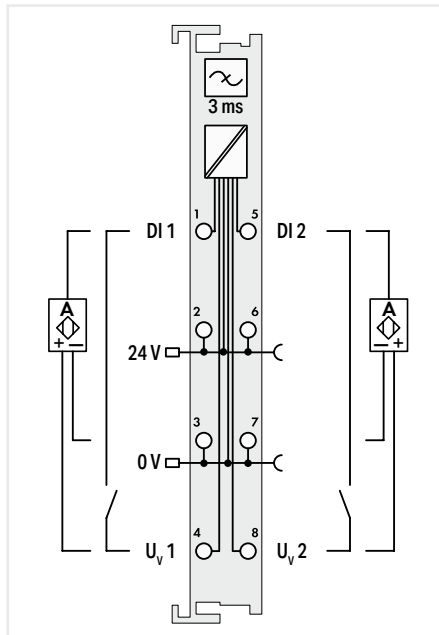

Diagnostics
Item description
Version
Item no.
Order Text

Short circuit, active acknowledgment after error rectified	
2-Channel Digital Input; 24 VDC; 3 ms; Acknowledgment; Diagnostics	
Standard	pluggable (delivery without connector)
750-418	753-418
2DI; 24 VDC; 3ms; Acknol; Diagn	2DI; 24 VDC; 3ms; Acknol; Diagn

Short circuit, automatic acknowledgment after error rectified	
2-Channel Digital Input; 24 VDC; 3 ms; Diagnostics	
Standard	pluggable (delivery without connector)
750-421	753-421
2DI; 24 VDC; 3ms; Diagn	2DI; 24 VDC; 3ms; Diagn

7.2

Technical data
Pluggable connector
Number of digital inputs
Signal type
Signal type (voltage)
Voltage range for signal (0)
Voltage range for signal (1)
Sensor connection
Input characteristic
Input filter (digital)
Input current per channel for signal (1) typ.
Output current per channel
Diagnostics
Supply voltage (sensor)
Supply voltage (field)
Current consumption (5 V system supply)
Input data width (internal) max.
Output data width (internal) max.
Isolation
Ambient temperature (operation)
Dimensions W x H x D
Approvals
For data sheet and additional information, see:
Accessories
Plug

	fixed	pluggable
Number of digital inputs		2
Signal type		Digital
Signal type (voltage)		24 VDC
Voltage range for signal (0)		-3 ... +5 VDC
Voltage range for signal (1)		15 ... 30 VDC
Sensor connection		2 x (2-wire, 3-wire)
Input characteristic		high-side switching
Input filter (digital)		3 ms
Input current per channel for signal (1) typ.		3.7 mA
Output current per channel		0.5 A
Diagnostics	Short circuit, active acknowledgment after error rectified	
Supply voltage (sensor)	24 VDC; Each channel is supplied separately with a short-circuit-protected voltage. A short circuit to ground is indicated as an error/fieldbus failure and a message is sent to the supervisory control. The error is canceled via the controller after it has been rectified (active acknowledgment by a user).	
Supply voltage (field)	24 VDC (-25 ... +30 %); via power jumper contacts (power supply via blade contact; transmission via spring contact)	
Current consumption (5 V system supply)		12 mA
Input data width (internal) max.		4 bits
Output data width (internal) max.		4 bits
Isolation		500 V system/field
Ambient temperature (operation)		0 ... +55 °C
Dimensions W x H x D		(12 x 100 x 69.8) mm
Approvals	CE; Marine; OrdLoc/HazLoc; ATEX/IECEx	
For data sheet and additional information, see:	wago.com/750-418	wago.com/753-418
Accessories	Item no.	Item no.
Plug	-	753-110

	fixed	pluggable
Number of digital inputs		2
Signal type		Digital
Signal type (voltage)		24 VDC
Voltage range for signal (0)		-3 ... +5 VDC
Voltage range for signal (1)		15 ... 30 VDC
Sensor connection		2 x (2-wire, 3-wire)
Input characteristic		high-side switching
Input filter (digital)		3 ms
Input current per channel for signal (1) typ.		3.7 mA
Output current per channel		0.5 A
Diagnostics	Short circuit, automatic acknowledgment after error rectified	
Supply voltage (sensor)	24 VDC; Each channel is supplied separately with a short-circuit-protected voltage. A short circuit to ground is indicated as an error/fieldbus failure and a message is sent to the supervisory control. The error is canceled automatically after it has been rectified.	
Supply voltage (field)	24 VDC (-25 ... +30 %); via power jumper contacts (power supply via blade contact; transmission via spring contact)	
Current consumption (5 V system supply)		12 mA
Input data width (internal) max.		4 bits
Output data width (internal) max.		-
Isolation		500 V system/field
Ambient temperature (operation)		0 ... +55 °C
Dimensions W x H x D		(12 x 100 x 69.8) mm
Approvals	CE; Marine; OrdLoc/HazLoc; ATEX/IECEx	
For data sheet and additional information, see:	wago.com/750-421	wago.com/753-421
Accessories	Item no.	Item no.
Plug	-	753-110

Digital input ▶ 24 VDC ▶ high-side switching ▶ 3 ms



750-400

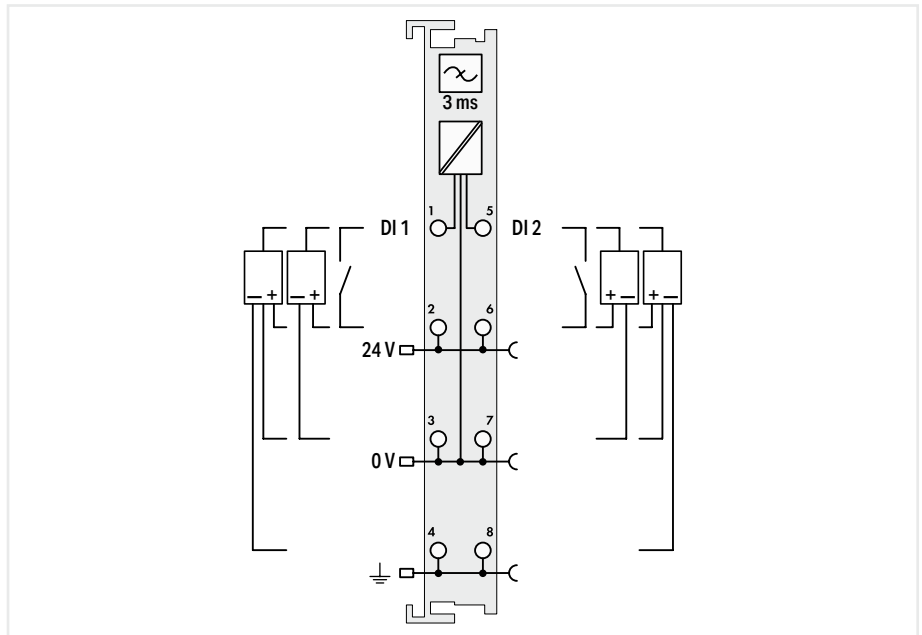

Item description	2-Channel Digital Input; 24 VDC; 3 ms		
Version	Standard	ext. temperature	pluggable (delivery without connector)
Item no.	750-400	750-400/025-000	753-400
Order Text	2DI; 24 VDC; 3ms	2DI; 24 VDC; 3ms; T	2DI; 24 VDC; 3ms

Technical data	fixed		pluggable
	Pluggable connector	fixed	
Number of digital inputs	2		
Signal type	Digital		
Signal type (voltage)	24 VDC		
Voltage range for signal (0)	-3 ... +5 VDC		
Voltage range for signal (1)	15 ... 30 VDC		
Sensor connection	2 x (2-wire, 3-wire, 4-wire)		
Input characteristic	high-side switching		
Input filter (digital)	3 ms		
Input current per channel for signal (1) typ.	4.5 mA		
Supply voltage (sensor)	24 VDC		
Supply voltage (field)	24 VDC (-25 ... +30 %); via power jumper contacts (power supply via blade contact; transmission via spring contact)		
Current consumption (5 V system supply)	3.7 mA		
Input data width (internal) max.	2 bits		
Isolation	500 V system/field		
Ambient temperature (operation)	0 ... +55 °C	-20 ... +60 °C	0 ... +55 °C
Dimensions W x H x D	(12 x 100 x 69.8) mm		
Approvals	CE, L, Marine, OrdLoc/HazLoc, ATEX/IECEX		
For data sheet and additional information, see:	wago.com/750-400		wago.com/753-400
Accessories	Item no.	Item no.	Item no.
Plug	-	-	753-110

7.2 Digital Input Modules

Digital input ▶ 24 VDC ▶ high-side switching ▶ 3 ms



750-402

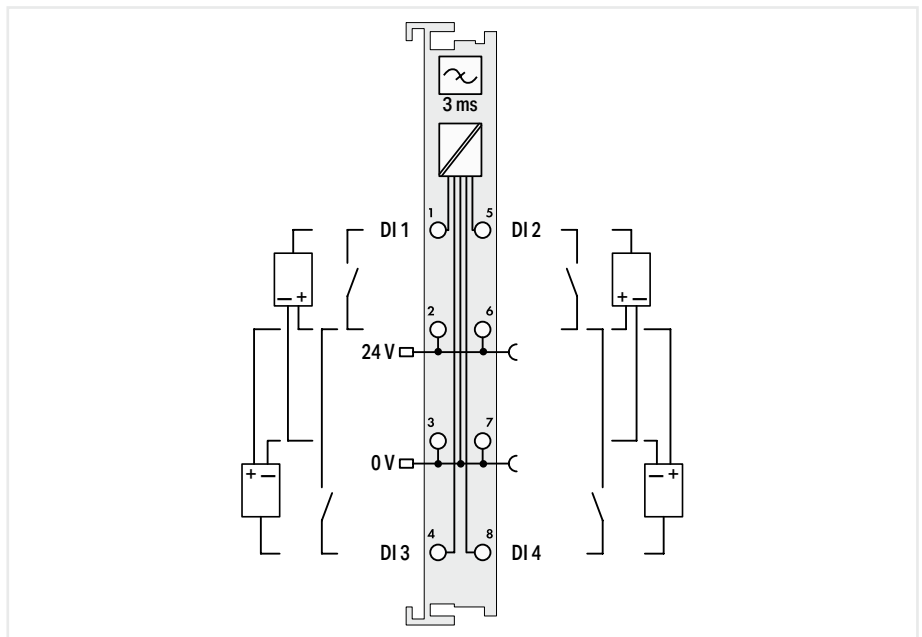

Item description	4-Channel Digital Input; 24 VDC; 3 ms		
Version	Standard	ext. temperature	pluggable (delivery without connector)
Item no.	750-402	750-402/025-000	753-402
Order Text	4DI; 24 VDC; 3ms	4DI; 24 VDC; 3ms; T	4DI; 24 VDC; 3ms

Technical data			
Pluggable connector	fixed		pluggable
Number of digital inputs	4		
Signal type	Digital		
Signal type (voltage)	24 VDC		
Voltage range for signal (0)	-3 ... +5 VDC		
Voltage range for signal (1)	15 ... 30 VDC		
Sensor connection	2 x (2-wire, 3-wire); A suitable field side connection module (e.g., 750-614) must also be used to connect other sensors.		
Input characteristic	high-side switching		
Input filter (digital)	3 ms		
Input current per channel for signal (1) typ.	4.5 mA		
Supply voltage (sensor)	24 VDC		
Supply voltage (field)	24 VDC (-25 ... +30 %); via power jumper contacts (power supply via blade contact; transmission via spring contact)		
Current consumption (5 V system supply)	7.5 mA		
Input data width (internal) max.	4 bits		
Isolation	500 V system/field		
Ambient temperature (operation)	0 ... +55 °C	-20 ... +60 °C	0 ... +55 °C
Dimensions W x H x D	(12 x 100 x 69.8) mm		
Approvals	CE; Marine; OrdLoc/HazLoc; ATEX/IECEX		
For data sheet and additional information, see:	wago.com/750-402		wago.com/753-402
Accessories	Item no.	Item no.	Item no.
Plug	-	-	753-110

7.2

Digital input ▶ 24 VDC ▶ high-side switching ▶ 3 ms



750-432

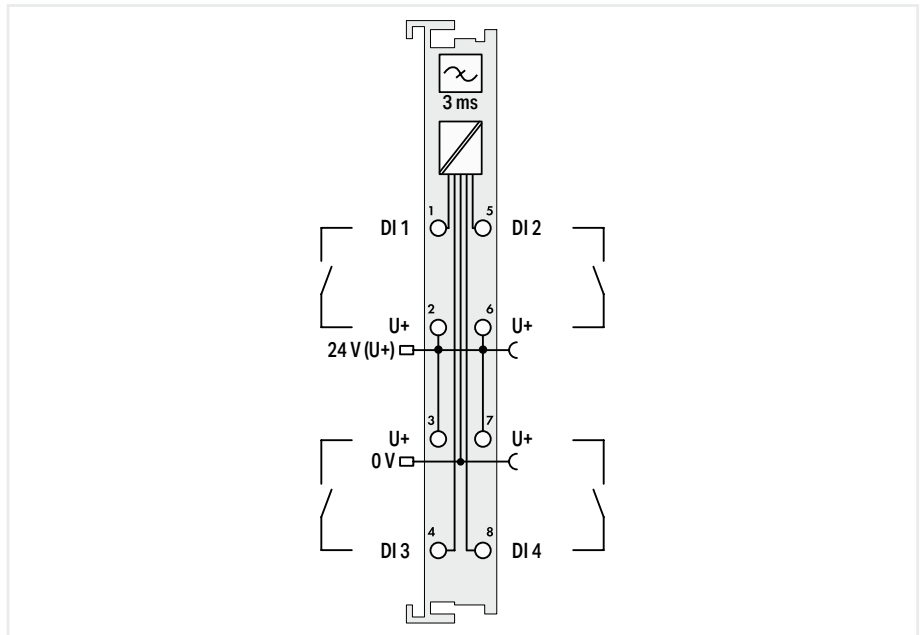

Item description	4-Channel Digital Input; 24 VDC; 3 ms; 2-wire connection	
Version	Standard	pluggable (delivery without connector)
Item no.	750-432	753-432
Order Text	4DI; 24 VDC; 3ms; 2-wire	4DI; 24 VDC; 3ms; 2-wire

Technical data	fixed	pluggable
Pluggable connector		
Number of digital inputs		4
Signal type		Digital
Signal type (voltage)		24 VDC
Voltage range for signal (0)		-3 ... +5 VDC
Voltage range for signal (1)		15 ... 30 VDC
Sensor connection		4 x (2-wire)
Input characteristic		high-side switching
Input filter (digital)		3 ms
Input current per channel for signal (1) typ.		4.5 mA
Supply voltage (sensor)		24 VDC
Supply voltage (field)	24 VDC (-25 ... +30 %); via power jumper contacts (power supply via blade contact; transmission via spring contact)	
Current consumption (5 V system supply)		5.5 mA
Input data width (internal) max.		4 bits
Isolation		500 V system/field
Ambient temperature (operation)		0 ... +55 °C
Dimensions W x H x D		(12 x 100 x 69.8) mm
Approvals	CE; Marine; OrdLoc/HazLoc; ATEX/IECEx	
For data sheet and additional information, see:	wago.com/750-432	wago.com/753-432
Accessories	Item no.	Item no.
Plug	-	753-110

7.2
Digital Input
Modules

Digital input ▶ 24 VDC ▶ high-side switching ▶ 3 ms



750-1420

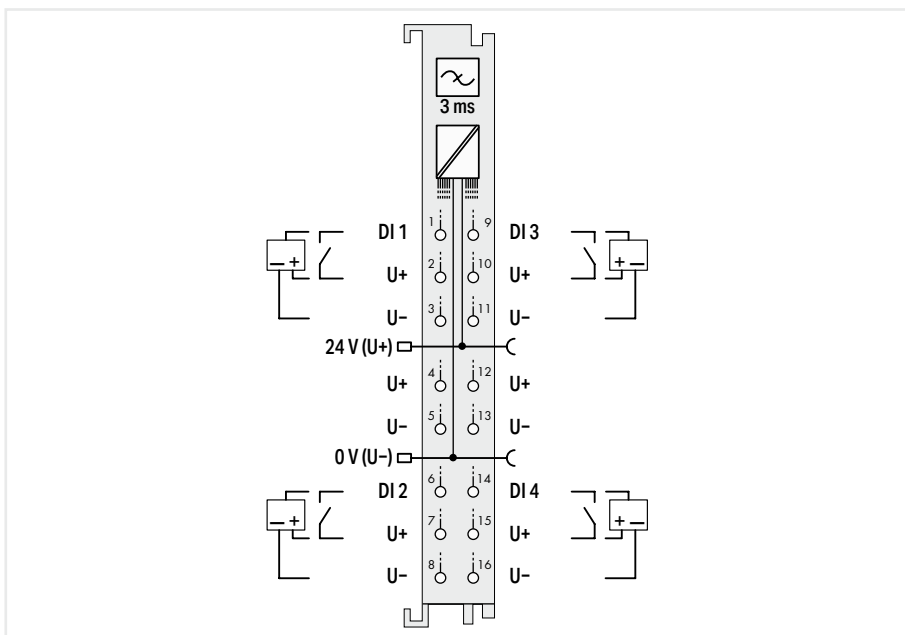

Item description	4-Channel Digital Input; 24 VDC; 3 ms; 3-wire connection
Version	Standard with 16 connectors
Item no.	750-1420
Order Text	4DI; 24 VDC; 3ms; 3-wire

Technical data

Pluggable connector	fixed
Number of digital inputs	4
Signal type	Digital
Signal type (voltage)	24 VDC
Voltage range for signal (0)	-3 ... +5 VDC
Voltage range for signal (1)	11 ... 30 VDC
Input characteristic	Type 3
Sensor connection	4 x (3-wire)
Input characteristic	high-side switching
Input filter (digital)	3 ms
Input current per channel for signal (1) typ.	4.5 mA
Input current per channel for signal (0) typ.	1.6 mA
Current consumption, field supply (module with no external load)	2 mA
Supply voltage (sensor)	24 VDC
Supply voltage (field)	24 VDC (-25 ... +30 %); via power jumper contacts (power supply via blade contact; transmission via spring contact)
Current consumption (5 V system supply)	4 mA
Input data width (internal) max.	4 bits
Isolation	500 V system/field
Ambient temperature (operation)	0 ... +55 °C
Dimensions W x H x D	(12 x 100 x 69) mm
Approvals	CE; Marine; OrdLoc/HazLoc; ATEX/IECEx

For data sheet and additional information, see:

wago.com/750-1420

Digital input ▶ 24 VDC ▶ high-side switching ▶ 3 ms



750-430

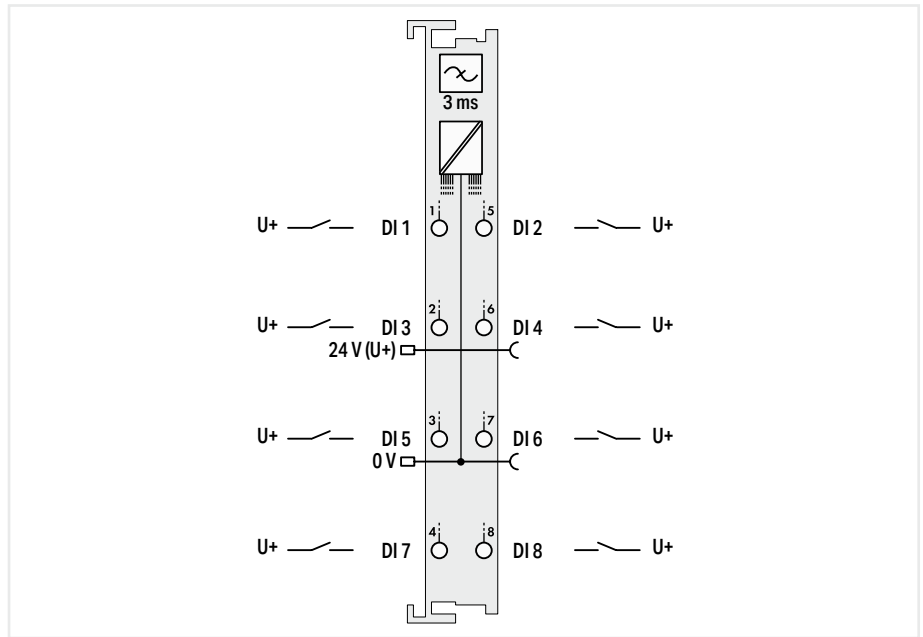

Item description	8-Channel Digital Input; 24 VDC; 3 ms		
Version	Standard	ext. temperature	pluggable (delivery without connector)
Item no.	750-430	750-430/025-000	753-430
Order Text	8DI; 24 VDC; 3ms	8DI; 24 VDC; 3ms; T	8DI; 24 VDC; 3ms

Technical data			
Pluggable connector	fixed		pluggable
Number of digital inputs	8		
Signal type	Digital		
Signal type (voltage)	24 VDC		
Voltage range for signal (0)	-3 ... +5 VDC		
Voltage range for signal (1)	15 ... 30 VDC		
Sensor connection	8 x (1-wire)		
Input characteristic	high-side switching		
Input filter (digital)	3 ms		
Input current per channel for signal (1) typ.	2.8 mA		
Supply voltage (field)	24 VDC (-25 ... +30 %); via power jumper contacts (power supply via blade contact; transmission via spring contact)		
Current consumption (5 V system supply)	17 mA		
Input data width (internal) max.	8 bits		
Isolation	500 V system/field		
Ambient temperature (operation)	0 ... +55 °C	-20 ... +60 °C	0 ... +55 °C
Dimensions W x H x D	(12 x 100 x 67.8) mm		(12 x 100 x 69) mm
Approvals	CE; Marine; OrdLoc/HazLoc; ATEX/IECEX		
For data sheet and additional information, see:	wago.com/750-430		wago.com/753-430
Accessories	Item no.	Item no.	Item no.
Plug	-	-	753-110

7.2 Digital Input Modules

Digital input ▶ 24 VDC ▶ high-side switching ▶ 3 ms



750-1415

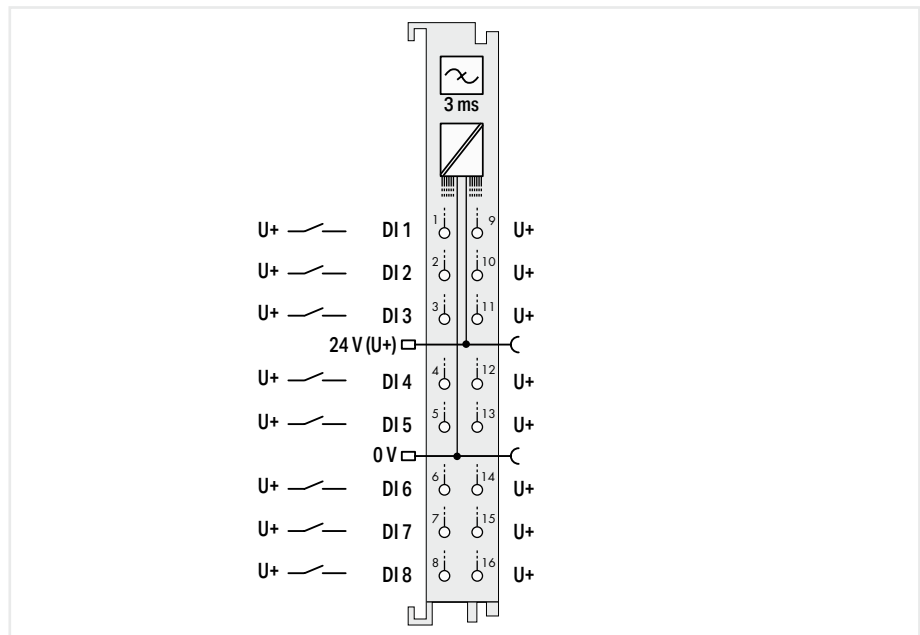

Item description	8-Channel Digital Input; 24 VDC; 3 ms; 2-wire connection
Version	Standard with 16 connectors
Item no.	750-1415
Order Text	8DI; 24 VDC; 3ms; 2-wire

Technical data	
Pluggable connector	fixed
Number of digital inputs	8
Signal type	Digital
Signal type (voltage)	24 VDC
Voltage range for signal (0)	-3 ... +5 VDC
Voltage range for signal (1)	11 ... 30 VDC
Input characteristic	Type 3
Sensor connection	8 x (2-wire)
Input characteristic	high-side switching
Input filter (digital)	3 ms
Input current per channel for signal (1) typ.	4.5 mA
Input current per channel for signal (0) typ.	1.6 mA
Current consumption, field supply (module with no external load)	2 mA
Supply voltage (sensor)	24 VDC
Supply voltage (field)	24 VDC (-25 ... +30 %); via power jumper contacts (power supply via blade contact; transmission via spring contact)
Current consumption (5 V system supply)	6 mA
Input data width (internal) max.	8 bits
Isolation	500 V system/field
Ambient temperature (operation)	0 ... +55 °C
Dimensions W x H x D	(12 x 100 x 69) mm
Approvals	CE; Marine; OrdLoc/HazLoc; ATEX/IECEX

For data sheet and additional information, see:

wago.com/750-1415

Digital input ▶ 24 VDC ▶ high-side switching ▶ 3 ms



750-1400

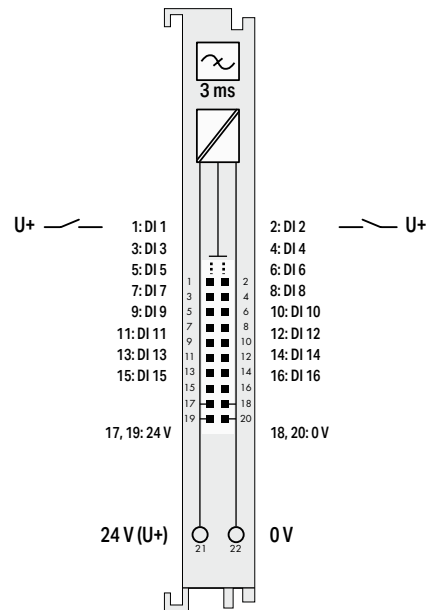

Item description	16-Channel Digital Input; 24 VDC; 3 ms; Ribbon cable
Version	Standard with ribbon cable connector
Item no.	750-1400
Order Text	16DI; 24 VDC; 3ms; Ribbon Cable

Technical data	
Pluggable connector	fixed
Number of digital inputs	16
Signal type	Digital
Signal type (voltage)	24 VDC
Voltage range for signal (0)	-3 ... +5 VDC
Voltage range for signal (1)	15 ... 30 VDC
Sensor connection	16 x (1-wire)
Input characteristic	high-side switching
Input filter (digital)	3 ms
Input current per channel for signal (1) typ.	2.3 mA
Input current per channel for signal (0) typ.	0.6 mA
Supply voltage (sensor)	24 VDC
Supply voltage (field)	24 VDC (-25 ... +30 %); via pluggable connector (CAGE CLAMP® connection)
Current consumption (5 V system supply)	25 mA
Input data width (internal) max.	16 bits
Isolation	500 V system/field
Ambient temperature (operation)	0 ... +55 °C
Dimensions W x H x D	(12 x 100 x 74.1) mm
Approvals	CE; Marine; OrdLoc/HazLoc; ATEX/IECEx

For data sheet and additional information, see:

wago.com/750-1400

Digital input ▶ 24 VDC ▶ high-side switching ▶ 3 ms



750-1405

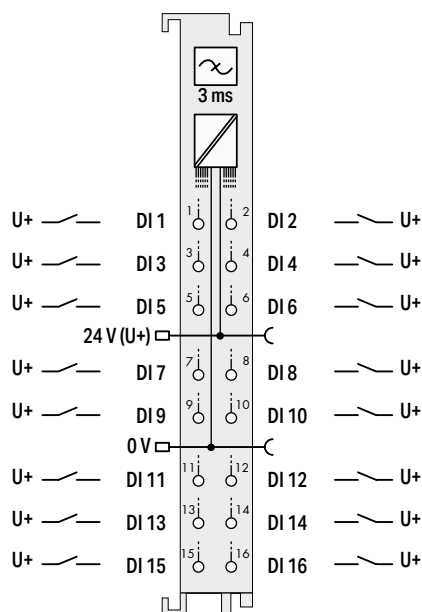

Item description	16-Channel Digital Input; 24 VDC; 3 ms
Version	Standard with 16 connectors
Item no.	750-1405
Order Text	16DI; 24 VDC; 3ms
Technical data	
Pluggable connector	fixed
Number of digital inputs	16
Signal type	Digital
Signal type (voltage)	24 VDC
Voltage range for signal (0)	-3 ... +5 VDC
Voltage range for signal (1)	15 ... 30 VDC
Sensor connection	16 x (1-wire)
Input characteristic	high-side switching
Input filter (digital)	3 ms
Input current per channel for signal (1) typ.	2.3 mA
Input current per channel for signal (0) typ.	0.6 mA
Supply voltage (field)	24 VDC (-25 ... +30 %); via power jumper contacts (power supply via blade contact; transmission via spring contact)
Current consumption (5 V system supply)	25 mA
Input data width (internal) max.	16 bits
Isolation	500 V system/field
Ambient temperature (operation)	0 ... +55 °C
Dimensions W x H x D	(12 x 100 x 69) mm
Approvals	CE; Marine; OrdLoc/HazLoc; ATEX/IECEX
For data sheet and additional information, see:	wago.com/750-1405

Digital input; Digital output ▶ 24 VDC ▶ high-side switching ▶ 3 ms



750-1502

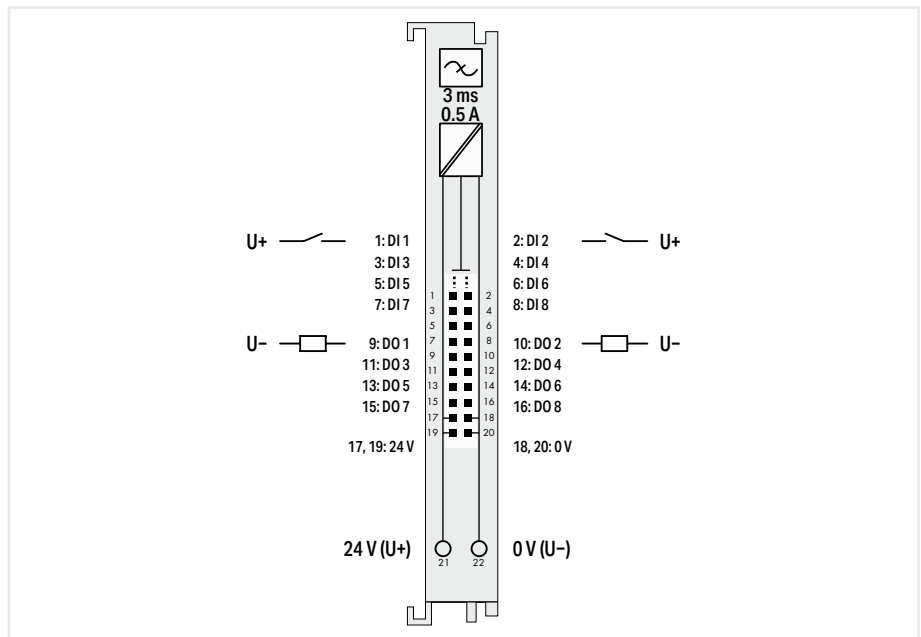

Item description	8-Channel Digital Input/Output; 24 VDC; 0.5 A; Ribbon cable
Version	Standard with ribbon cable connector
Item no.	750-1502
Order Text	8DIO; 24 VDC; 0.5A; Ribbon Cable

Technical data

Pluggable connector	fixed
Number of digital inputs	8
Voltage range for signal (0)	-3 ... +5 VDC
Voltage range for signal (1)	15 ... 30 VDC
Sensor connection	8 x (1-wire)
Input characteristic	high-side switching
Input filter (digital)	3 ms
Input current per channel for signal (1) typ.	2.4 mA
Number of digital outputs	8
Signal type	Digital
Signal type (voltage)	24 VDC
Output characteristic	high-side switching
Output current per channel	0.5 A
Output current	short-circuit-protected
Load type	Resistive, inductive, lamp load
Actuator connection	8 x (1-wire)
Switching frequency (max.)	1 kHz
Supply voltage (field)	24 VDC (-25 ... +30 %); via pluggable connector (CAGE CLAMP® connection)
Current consumption, field supply (module with no external load)	16 mA
Current consumption (5 V system supply)	30 mA
Input data width (internal) max.	8 bits
Output data width (internal) max.	8 bits
Isolation	500 V system/field
Ambient temperature (operation)	0 ... +55 °C
Dimensions W x H x D	(12 x 100 x 74.1) mm
Approvals	CE; Marine; OrdLoc/HazLoc; ATEX/IECEx
For data sheet and additional information, see:	wago.com/750-1502

Digital input; Digital output ▶ 24 VDC ▶ high-side switching ▶ 3 ms



750-1506

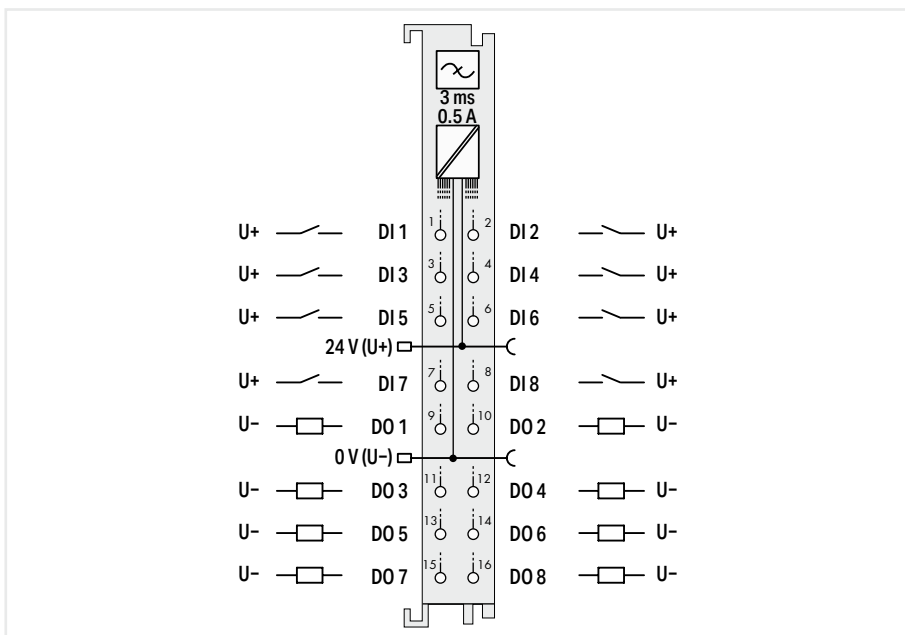

Item description	8-Channel Digital Input/Output; 24 VDC; 0.5 A
Version	Standard with 16 connectors
Item no.	750-1506
Order Text	8DIO; 24 VDC; 0.5A

Technical data

Pluggable connector	fixed
Number of digital inputs	8
Voltage range for signal (0)	-3 ... +5 VDC
Voltage range for signal (1)	15 ... 30 VDC
Sensor connection	8 x (1-wire)
Input characteristic	high-side switching
Input filter (digital)	3 ms
Input current per channel for signal (1) typ.	2.4 mA
Number of digital outputs	8
Signal type	Digital
Signal type (voltage)	24 VDC
Output characteristic	high-side switching
Output current per channel	0.5 A
Output current	short-circuit-protected
Load type	Resistive, inductive, lamp load
Actuator connection	8 x (1-wire)
Switching frequency (max.)	1 kHz
Supply voltage (field)	24 VDC (-25 ... +30 %); via power jumper contacts (power supply via blade contact; transmission via spring contact)
Current consumption, field supply (module with no external load)	16 mA
Current consumption (5 V system supply)	30 mA
Input data width (internal) max.	8 bits
Output data width (internal) max.	8 bits
Isolation	500 V system/field
Ambient temperature (operation)	0 ... +55 °C
Dimensions W x H x D	(12 x 100 x 69) mm
Approvals	CE; Marine; OrdLoc/HazLoc; ATEX/IECEX
For data sheet and additional information, see:	wago.com/750-1506

Digital input ▶ 24 VDC ▶ high-side switching ▶ 0.2 ms



750-401

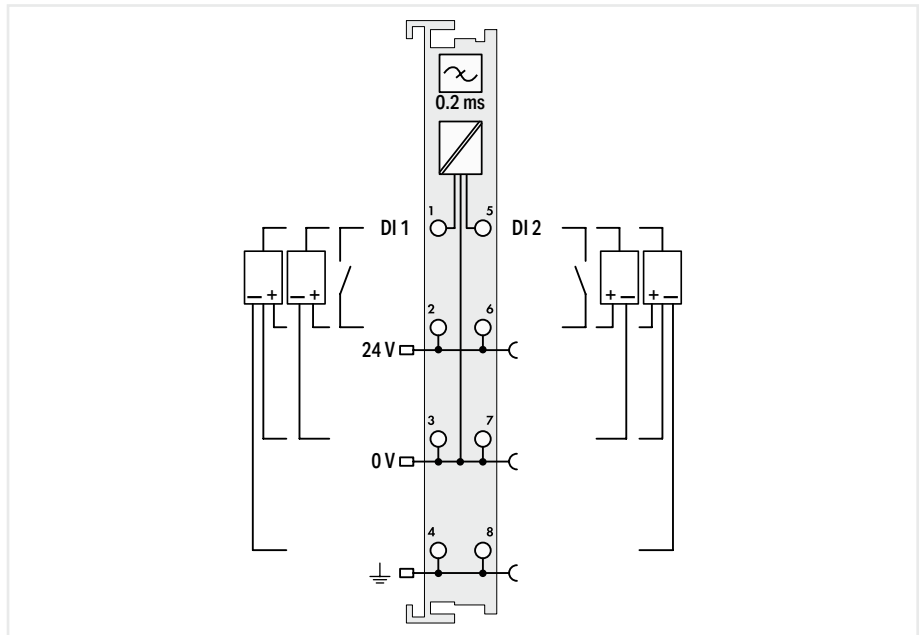

Item description	2-Channel Digital Input; 24 VDC; 0.2 ms	
Version	Standard	pluggable (delivery without connector)
Item no.	750-401	753-401
Order Text	2DI; 24 VDC; 0.2ms	2DI; 24 VDC; 0.2ms

Technical data	fixed	pluggable
Pluggable connector		
Number of digital inputs		2
Signal type		Digital
Signal type (voltage)		24 VDC
Voltage range for signal (0)		-3 ... +5 VDC
Voltage range for signal (1)		15 ... 30 VDC
Sensor connection		2 x (2-wire, 3-wire, 4-wire)
Input characteristic		high-side switching
Input filter (digital)		0.2 ms
Input current per channel for signal (1) typ.		4.5 mA
Supply voltage (sensor)		24 VDC
Supply voltage (field)	24 VDC (-25 ... +30 %); via power jumper contacts (power supply via blade contact; transmission via spring contact)	
Current consumption (5 V system supply)		3.7 mA
Input data width (internal) max.		2 bits
Isolation		500 V system/field
Ambient temperature (operation)		0 ... +55 °C
Dimensions W x H x D		(12 x 100 x 69.8) mm
Approvals	CE; Marine; OrdLoc/HazLoc; ATEX/IECEx	
For data sheet and additional information, see:	wago.com/750-401	wago.com/753-401
Accessories	Item no.	Item no.
Plug	-	753-110

Digital input ▶ 24 VDC ▶ high-side switching ▶ 0.2 ms



750-403

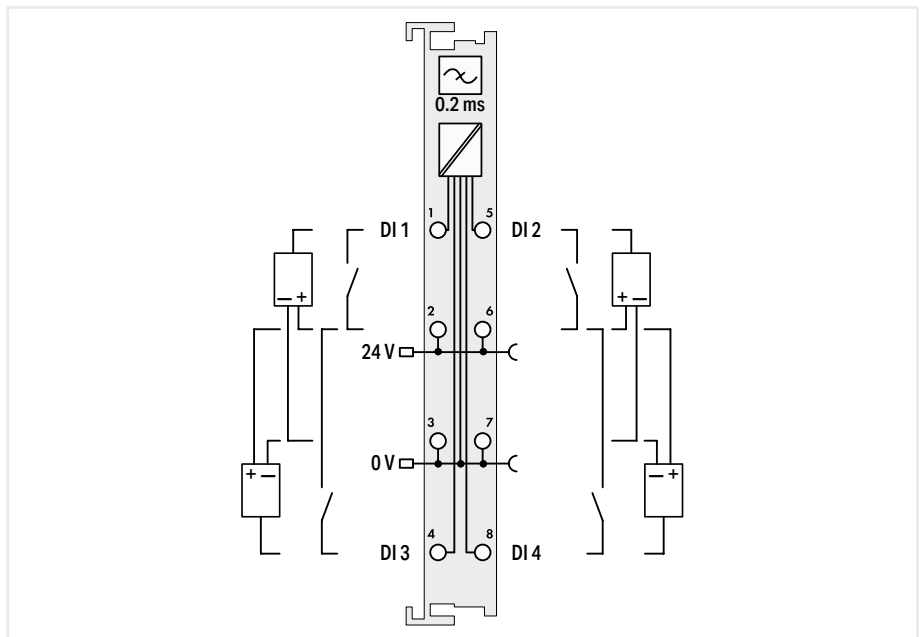

Item description	4-Channel Digital Input; 24 VDC; 0.2 ms	
Version	Standard	pluggable (delivery without connector)
Item no.	750-403	753-403
Order Text	4DI; 24 VDC; 0.2ms	4DI; 24 VDC; 0.2ms

Technical data	fixed	pluggable
Pluggable connector		
Number of digital inputs		4
Signal type		Digital
Signal type (voltage)		24 VDC
Voltage range for signal (0)		-3 ... +5 VDC
Voltage range for signal (1)		15 ... 30 VDC
Sensor connection	2 x (2-wire, 3-wire); A suitable field side connection module (e.g., 750-614) must also be used to connect other sensors.	
Input characteristic	high-side switching	
Input filter (digital)	0.2 ms	
Input current per channel for signal (1) typ.	4.5 mA	
Supply voltage (sensor)	24 VDC	
Supply voltage (field)	24 VDC (-25 ... +30 %); via power jumper contacts (power supply via blade contact; transmission via spring contact)	
Current consumption (5 V system supply)	7.5 mA	
Input data width (internal) max.	4 bits	
Isolation	500 V system/field	
Ambient temperature (operation)	0 ... +55 °C	
Dimensions W x H x D	(12 x 100 x 69.8) mm	
Approvals	CE; Marine; OrdLoc/HazLoc; ATEX/IECEx	
For data sheet and additional information, see:	wago.com/750-403	wago.com/753-403
Accessories	Item no.	Item no.
Plug	-	753-110

7.2

Digital input ▶ 24 VDC ▶ high-side switching ▶ 0.2 ms



750-433

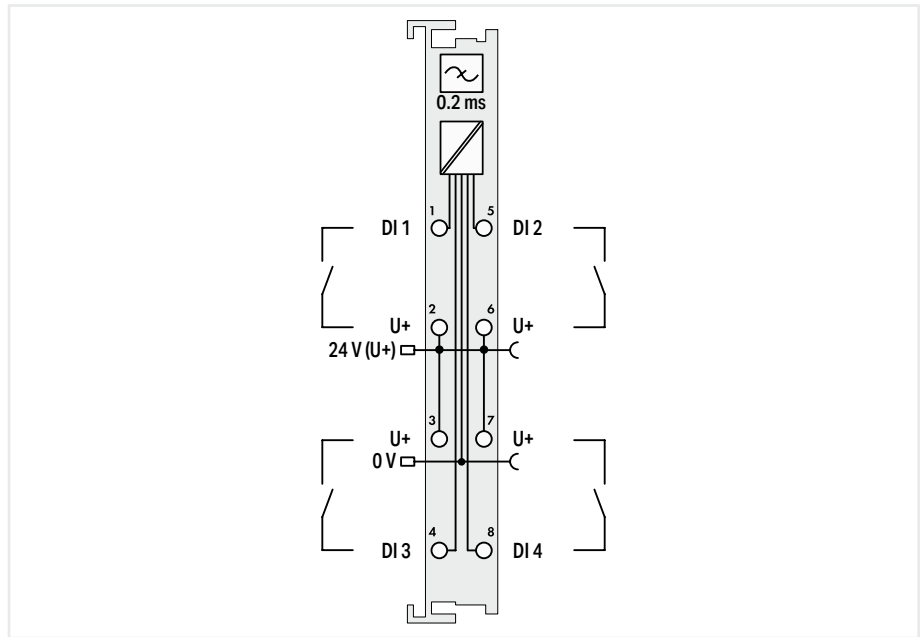

Item description	4-Channel Digital Input; 24 VDC; 0.2 ms; 2-wire connection	
Version	Standard	pluggable (delivery without connector)
Item no.	750-433	753-433
Order Text	4DI; 24 VDC; 0.2ms; 2-wire	4DI; 24 VDC; 0.2ms; 2-wire

Technical data	fixed	pluggable
Pluggable connector		
Number of digital inputs		4
Signal type		Digital
Signal type (voltage)		24 VDC
Voltage range for signal (0)		-3 ... +5 VDC
Voltage range for signal (1)		15 ... 30 VDC
Sensor connection		4 x (2-wire)
Input characteristic		high-side switching
Input filter (digital)		0.2 ms
Input current per channel for signal (1) typ.		4.5 mA
Supply voltage (sensor)		24 VDC
Supply voltage (field)	24 VDC (-25 ... +30 %); via power jumper contacts (power supply via blade contact; transmission via spring contact)	
Current consumption (5 V system supply)		5.5 mA
Input data width (internal) max.		4 bits
Isolation		500 V system/field
Ambient temperature (operation)		0 ... +55 °C
Dimensions W x H x D		(12 x 100 x 69.8) mm
Approvals	CE; Marine; OrdLoc/HazLoc; ATEX/IECEx	
For data sheet and additional information, see:	wago.com/750-433	wago.com/753-433
Accessories	Item no.	Item no.
Plug	-	753-110

7.2
Digital Input
Modules

Digital input ▶ 24 VDC ▶ high-side switching ▶ 0.2 ms



750-1421

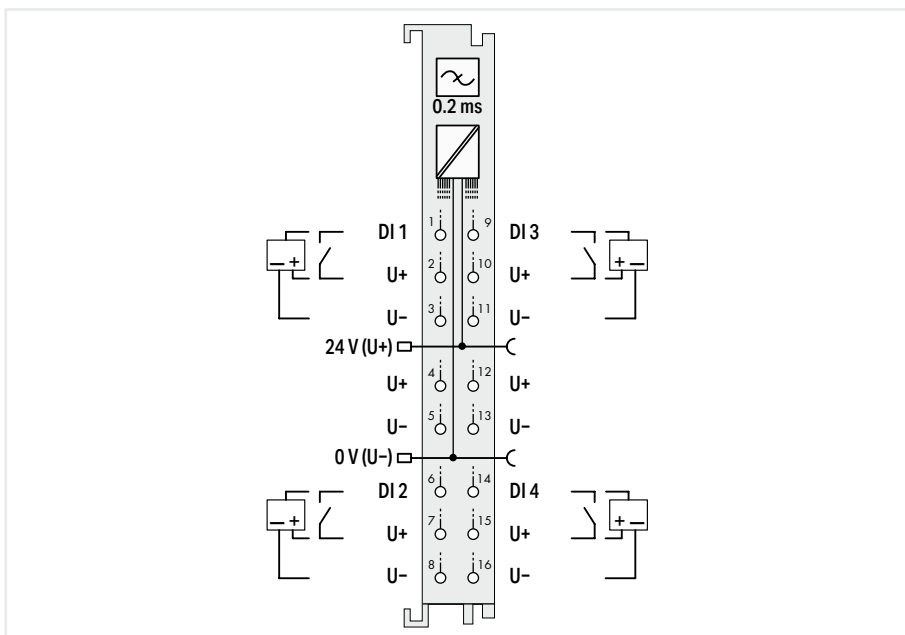

Item description	4-Channel Digital Input; 24 VDC; 0.2 ms; 3-wire connection
Version	Standard with 16 connectors
Item no.	750-1421
Order Text	4DI; 24 VDC; 0.2ms; 3-wire

Technical data

Pluggable connector	fixed
Number of digital inputs	4
Signal type	Digital
Signal type (voltage)	24 VDC
Voltage range for signal (0)	-3 ... +5 VDC
Voltage range for signal (1)	11 ... 30 VDC
Input characteristic	Type 3
Sensor connection	4 x (3-wire)
Input characteristic	high-side switching
Input filter (digital)	0.2 ms
Input current per channel for signal (1) typ.	4.5 mA
Input current per channel for signal (0) typ.	1.6 mA
Current consumption, field supply (module with no external load)	2 mA
Supply voltage (sensor)	24 VDC
Supply voltage (field)	24 VDC (-25 ... +30 %); via power jumper contacts (power supply via blade contact; transmission via spring contact)
Current consumption (5 V system supply)	4 mA
Input data width (internal) max.	4 bits
Isolation	500 V system/field
Ambient temperature (operation)	0 ... +55 °C
Dimensions W x H x D	(12 x 100 x 69) mm
Approvals	CE; Marine; OrdLoc/HazLoc; ATEX/IECEx

For data sheet and additional information, see:

wago.com/750-1421

Digital input ▶ 24 VDC ▶ high-side switching ▶ 0.2 ms



750-431

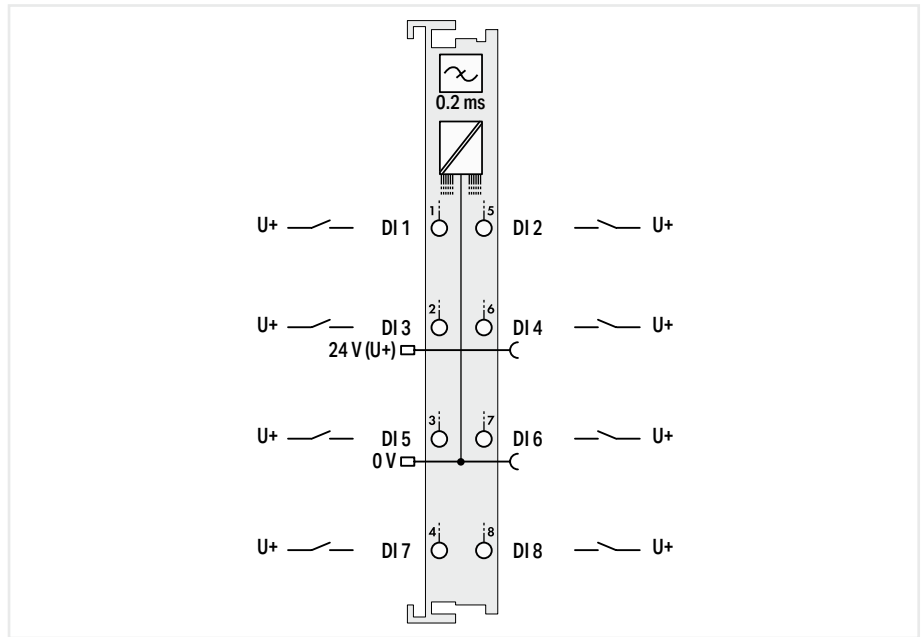

Item description	8-Channel Digital Input; 24 VDC; 0.2 ms	
Version	Standard	pluggable (delivery without connector)
Item no.	750-431	753-431
Order Text	8DI; 24 VDC; 0.2ms	8DI; 24 VDC; 0.2ms
Technical data	fixed	pluggable
Pluggable connector		
Number of digital inputs		8
Signal type		Digital
Signal type (voltage)		24 VDC
Voltage range for signal (0)		-3 ... +5 VDC
Voltage range for signal (1)		15 ... 30 VDC
Sensor connection		8 x (1-wire)
Input characteristic		high-side switching
Input filter (digital)		0.2 ms
Input current per channel for signal (1) typ.		2.8 mA
Supply voltage (field)	24 VDC (-25 ... +30 %); via power jumper contacts (power supply via blade contact; transmission via spring contact)	
Current consumption (5 V system supply)		17 mA
Input data width (internal) max.		8 bits
Isolation		500 V system/field
Ambient temperature (operation)		0 ... +55 °C
Dimensions W x H x D	(12 x 100 x 67.8) mm	(12 x 100 x 69) mm
Approvals	Marine; OrdLoc/HazLoc; ATEX/IECEX	
For data sheet and additional information, see:	wago.com/750-431	wago.com/753-431
Accessories	Item no.	Item no.
Plug	-	753-110

Digital input ▶ 24 VDC ▶ high-side switching ▶ 0.2 ms



750-1416

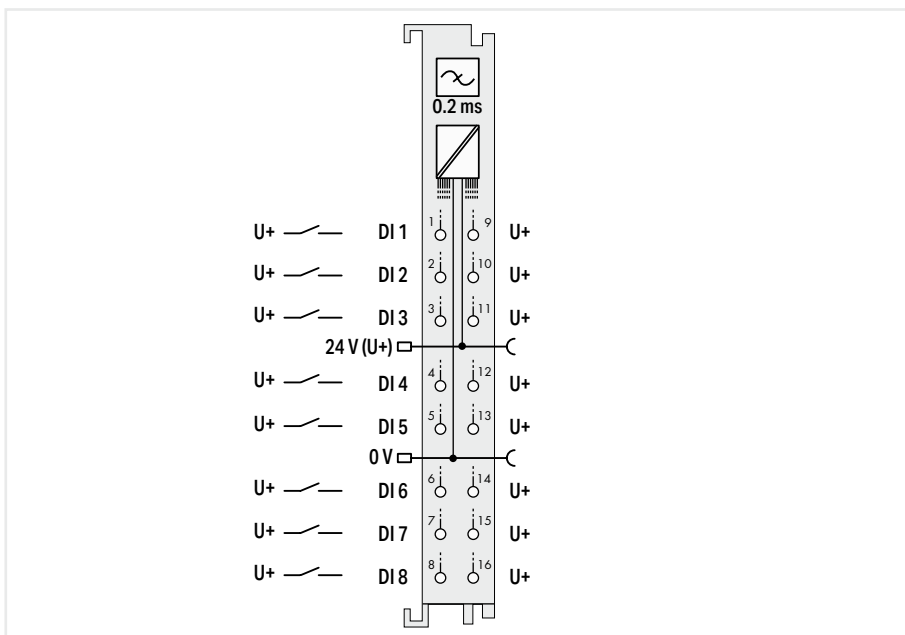

Item description	8-Channel Digital Input; 24 VDC; 0.2 ms; 2-wire connection
Version	Standard with 16 connectors
Item no.	750-1416
Order Text	8DI; 24 VDC; 0.2ms; 2-wire

Technical data

Pluggable connector	fixed
Number of digital inputs	8
Signal type	Digital
Signal type (voltage)	24 VDC
Voltage range for signal (0)	-3 ... +5 VDC
Voltage range for signal (1)	11 ... 30 VDC
Input characteristic	Type 3
Sensor connection	8 x (2-wire)
Input characteristic	high-side switching
Input filter (digital)	0.2 ms
Input current per channel for signal (1) typ.	4.5 mA
Input current per channel for signal (0) typ.	1.6 mA
Current consumption, field supply (module with no external load)	2 mA
Supply voltage (sensor)	24 VDC
Supply voltage (field)	24 VDC (-25 ... +30 %); via power jumper contacts (power supply via blade contact; transmission via spring contact)
Current consumption (5 V system supply)	6 mA
Input data width (internal) max.	8 bits
Isolation	500 V system/field
Ambient temperature (operation)	0 ... +55 °C
Dimensions W x H x D	(12 x 100 x 69) mm
Approvals	CE; Marine; OrdLoc/HazLoc; ATEX/IECEX

For data sheet and additional information, see:

wago.com/750-1416

Digital input ▶ 24 VDC ▶ high-side switching ▶ 0.2 ms



750-1406

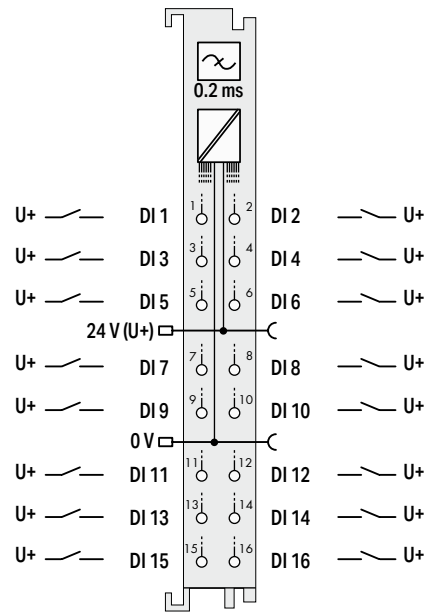

Item description	16-Channel Digital Input; 24 VDC; 0.2 ms
Version	Standard with 16 connectors
Item no.	750-1406
Order Text	16DI; 24 VDC; 0.2ms
Technical data	
Pluggable connector	fixed
Number of digital inputs	16
Signal type	Digital
Signal type (voltage)	24 VDC
Voltage range for signal (0)	-3 ... +5 VDC
Voltage range for signal (1)	15 ... 30 VDC
Sensor connection	16 x (1-wire)
Input characteristic	high-side switching
Input filter (digital)	0.2 ms
Input current per channel for signal (1) typ.	2.3 mA
Input current per channel for signal (0) typ.	0.6 mA
Supply voltage (field)	24 VDC (-25 ... +30 %); via power jumper contacts (power supply via blade contact; transmission via spring contact)
Current consumption (5 V system supply)	25 mA
Input data width (internal) max.	16 bits
Isolation	500 V system/field
Ambient temperature (operation)	0 ... +55 °C
Dimensions W x H x D	(12 x 100 x 69) mm
Approvals	CE; L; Marine; OrdLoc/HazLoc; ATEX/IECEX
For data sheet and additional information, see:	wago.com/750-1406

Digital input ▶ 24 VDC ▶ low-side switching ▶ 3 ms



750-408

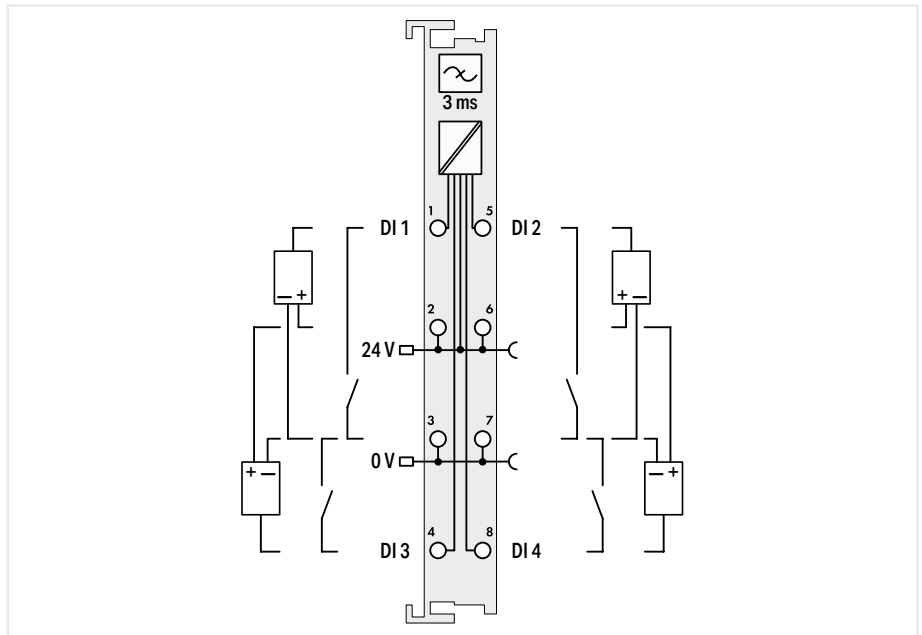

Item description	4-Channel Digital Input; 24 VDC; 3 ms; Low-side switching		
Version	Standard	ext. temperature	pluggable (delivery without connector)
Item no.	750-408	750-408/025-000	753-408
Order Text	4DI; 24 VDC; 3ms; LSS	4DI; 24 VDC; 3ms; LSS; T	4DI; 24 VDC; 3ms; LSS

Technical data			
Pluggable connector	fixed		pluggable
Number of digital inputs	4		
Signal type	Digital		
Signal type (voltage)	24 VDC		
Voltage range for signal (0)	$(U_V - 5 V) \dots U_V, DC$		
Voltage range for signal (1)	$-3 VDC \dots (U_V - 15 V)$		
Sensor connection	2 x (2-wire, 3-wire); A suitable field side connection module (e.g., 750-614) must also be used to connect other sensors.		
Input characteristic	low-side switching		
Input filter (digital)	3 ms		
Input current per channel for signal (0) typ.	7 mA		
Supply voltage (sensor)	24 VDC		
Supply voltage (field)	24 VDC (-15 ... +20 %); via power jumper contacts (power supply via blade contact; transmission via spring contact)		
Current consumption (5 V system supply)	5 mA		
Input data width (internal) max.	4 bits		
Isolation	500 V system/field		
Ambient temperature (operation)	0 ... +55 °C	-20 ... +60 °C	0 ... +55 °C
Dimensions W x H x D	(12 x 100 x 69.8) mm		
Approvals	CE; Marine; OrdLoc/HazLoc; ATEX/IECEX		
For data sheet and additional information, see:	wago.com/750-408		wago.com/753-408
Accessories	Item no.	Item no.	Item no.
Plug	-	-	753-110

7.2

Digital input ▶ 24 VDC ▶ low-side switching ▶ 3 ms



750-1422

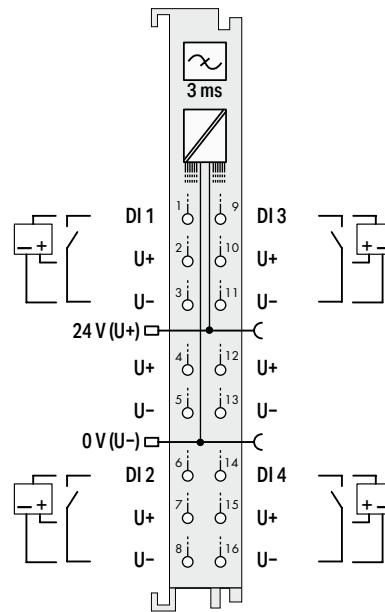

Item description	4-Channel Digital Input; 24 VDC; 3 ms; Low-side switching; 3-wire connection
Version	Standard with 16 connectors
Item no.	750-1422
Order Text	4DI; 24 VDC; 3ms; LSS; 3-wire

Technical data

Pluggable connector	fixed
Number of digital inputs	4
Signal type	Digital
Signal type (voltage)	24 VDC
Voltage range for signal (0)	$(U_V - 5 V) \dots U_V, DC$
Voltage range for signal (1)	$-3 VDC \dots (U_V - 15 V)$
Sensor connection	4 x (3-wire)
Input characteristic	low-side switching
Input filter (digital)	3 ms
Input current per channel for signal (1) typ.	-0.6 mA
Input current per channel for signal (0) typ.	-2.5 mA
Supply voltage (sensor)	24 VDC
Supply voltage (field)	24 VDC (-25 ... +30 %); via power jumper contacts (power supply via blade contact; transmission via spring contact)
Current consumption (5 V system supply)	7 mA
Input data width (internal) max.	4 bits
Isolation	500 V system/field
Ambient temperature (operation)	0 ... +55 °C
Dimensions W x H x D	(12 x 100 x 69) mm
Approvals	CE; Marine; OrdLoc/HazLoc; ATEX/IECEx

For data sheet and additional information, see:

wago.com/750-1422

Digital input ▶ 24 VDC ▶ low-side switching ▶ 3 ms



750-436

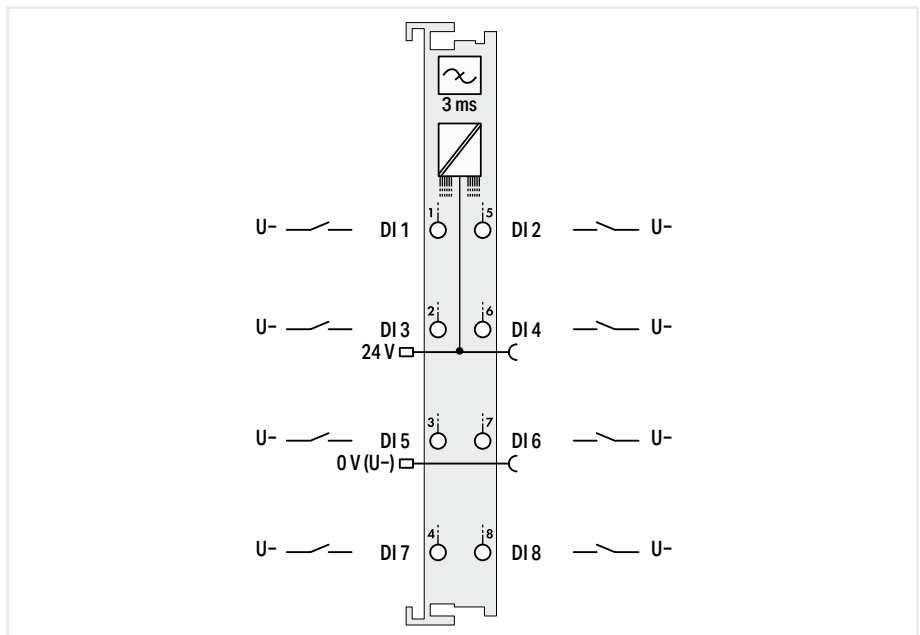

Item description	8-Channel Digital Input; 24 VDC; 3 ms; Low-side switching	
Version	Standard	pluggable (delivery without connector)
Item no.	750-436	753-436
Order Text	8DI; 24 VDC; 3ms; LSS	8DI; 24 VDC; 3ms; LSS
Technical data	fixed	pluggable
Pluggable connector		
Number of digital inputs		8
Signal type		Digital
Signal type (voltage)		24 VDC
Voltage range for signal (0)		15 ... 30 VDC
Voltage range for signal (1)		-3 ... +5 VDC
Sensor connection		8 x (1-wire)
Input characteristic		low-side switching
Input filter (digital)		3 ms
Input current per channel for signal (0) typ.		2.8 mA
Supply voltage (field)	24 VDC (-25 ... +30 %); via power jumper contacts (power supply via blade contact; transmission via spring contact)	
Current consumption (5 V system supply)		13 mA
Input data width (internal) max.		8 bits
Isolation	500 V system/field	
Ambient temperature (operation)	0 ... +55 °C	
Dimensions W x H x D	(12 x 100 x 67.8) mm	(12 x 100 x 69) mm
Approvals	CE; Marine; OrdLoc/HazLoc; ATEX/IECEX	
For data sheet and additional information, see:	wago.com/750-436	wago.com/753-436
Accessories	Item no.	Item no.
Plug	-	753-110

Digital input ▶ 24 VDC ▶ low-side switching ▶ 3 ms



750-1417

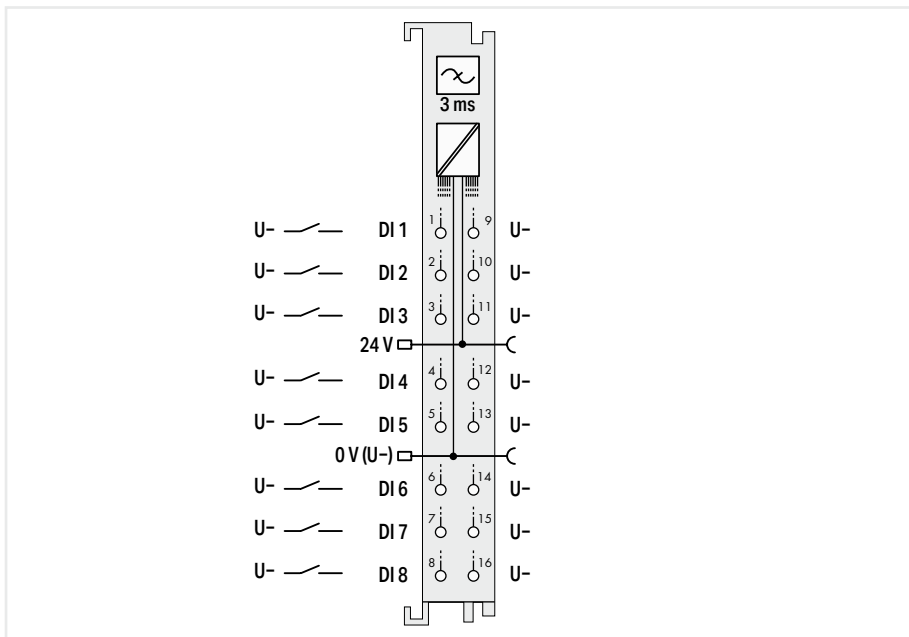

Item description	8-Channel Digital Input; 24 VDC; 3 ms; Low-side switching; 2-wire connection
Version	Standard with 16 connectors
Item no.	750-1417
Order Text	8DI; 24 VDC; 3ms; LSS; 2-wire

Technical data	
Pluggable connector	fixed
Number of digital inputs	8
Signal type	Digital
Signal type (voltage)	24 VDC
Voltage range for signal (0)	(U _V - 5 V) ... U _V DC
Voltage range for signal (1)	-3 VDC ... (U _V - 15 V)
Sensor connection	8 x (2-wire)
Input characteristic	low-side switching
Input filter (digital)	3 ms
Input current per channel for signal (1) typ.	-0.6 mA
Input current per channel for signal (0) typ.	2.4 mA
Supply voltage (sensor)	24 VDC
Supply voltage (field)	24 VDC (-25 ... +30 %); via power jumper contacts (power supply via blade contact; transmission via spring contact)
Current consumption (5 V system supply)	12 mA
Input data width (internal) max.	8 bits
Isolation	500 V system/field
Ambient temperature (operation)	0 ... +55 °C
Dimensions W x H x D	(12 x 100 x 69) mm
Approvals	CE; Marine; OrdLoc/HazLoc; ATEX/IECEX

For data sheet and additional information, see:

wago.com/750-1417

Digital input ▶ 24 VDC ▶ low-side switching ▶ 3 ms



750-1402

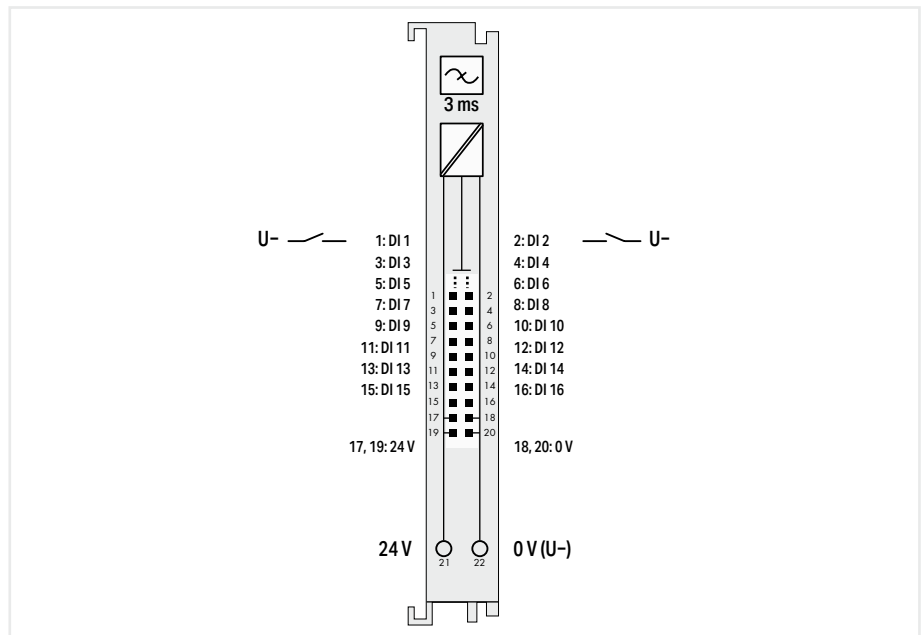

Item description	16-Channel Digital Input; 24 VDC; 3 ms; Low-side switching; Ribbon cable
Version	Standard with ribbon cable connector
Item no.	750-1402
Order Text	16DI; 24 VDC; 3ms; LSS; Ribbon Cable

Technical data	
Pluggable connector	fixed
Number of digital inputs	16
Signal type	Digital
Signal type (voltage)	24 VDC
Voltage range for signal (0)	$(U_V - 5 V) \dots U_V$ DC
Voltage range for signal (1)	$-3 VDC \dots (U_V - 15 V)$
Sensor connection	16 x (1-wire)
Input characteristic	low-side switching
Input filter (digital)	3 ms
Input current per channel for signal (1) typ.	-0.6 mA
Input current per channel for signal (0) typ.	2.3 mA
Supply voltage (sensor)	24 VDC
Supply voltage (field)	24 VDC (-25 ... +30 %); via pluggable connector (CAGE CLAMP® connection)
Current consumption (5 V system supply)	25 mA
Input data width (internal) max.	16 bits
Isolation	500 V system/field
Ambient temperature (operation)	0 ... +55 °C
Dimensions W x H x D	(12 x 100 x 74.1) mm
Approvals	CE; Marine; OrdLoc/HazLoc; ATEX/IECEx

For data sheet and additional information, see:

wago.com/750-1402

Digital input ▶ 24 VDC ▶ low-side switching ▶ 3 ms



750-1407

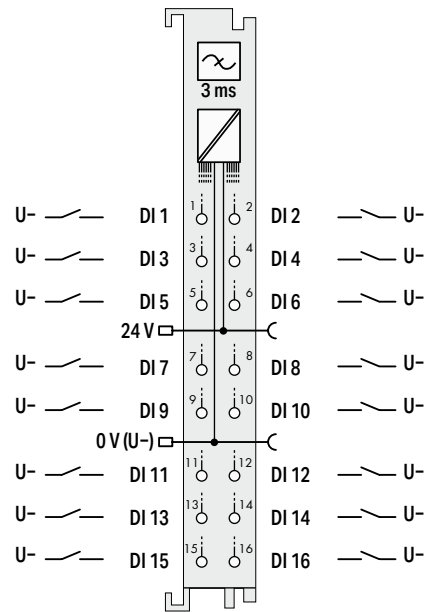

Item description	16-Channel Digital Input; 24 VDC; 3 ms; Low-side switching
Version	Standard with 16 connectors
Item no.	750-1407
Order Text	16DI; 24 VDC; 3ms; LSS
Technical data	
Pluggable connector	fixed
Number of digital inputs	16
Signal type	Digital
Signal type (voltage)	24 VDC
Voltage range for signal (0)	$(U_V - 5 \text{ V}) \dots U_V \text{ DC}$
Voltage range for signal (1)	$-3 \text{ VDC} \dots (U_V - 15 \text{ V})$
Sensor connection	16 x (1-wire)
Input characteristic	low-side switching
Input filter (digital)	3 ms
Input current per channel for signal (1) typ.	-0.6 mA
Input current per channel for signal (0) typ.	2.3 mA
Supply voltage (field)	24 VDC (-25 ... +30 %); via power jumper contacts (power supply via blade contact; transmission via spring contact)
Current consumption (5 V system supply)	25 mA
Input data width (internal) max.	16 bits
Isolation	500 V system/field
Ambient temperature (operation)	0 ... +55 °C
Dimensions W x H x D	(12 x 100 x 69) mm
Approvals	CE; L; Marine; OrdLoc/HazLoc; ATEX/IECEx
For data sheet and additional information, see:	wago.com/750-1407

Digital input ▶ 24 VDC ▶ low-side switching ▶ 0.2 ms



750-409

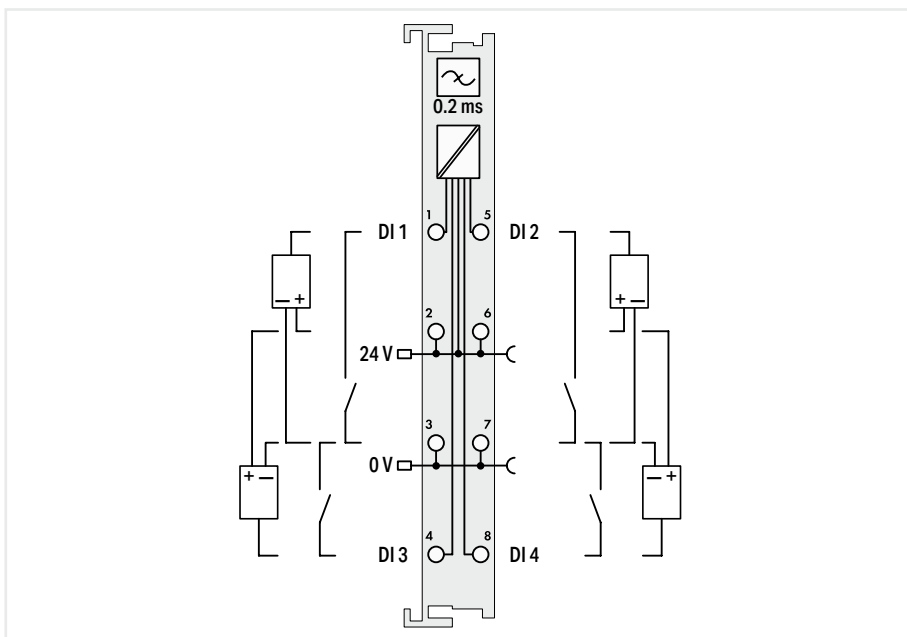

Item description	4-Channel Digital Input; 24 VDC; 0.2 ms; Low-side switching	
Version	Standard	pluggable (delivery without connector)
Item no.	750-409	753-409
Order Text	4DI; 24 VDC; 0.2ms; LSS	4DI; 24 VDC; 0.2ms; LSS

Technical data

	fixed	pluggable
Pluggable connector		
Number of digital inputs		4
Signal type		Digital
Signal type (voltage)		24 VDC
Voltage range for signal (0)		$(U_V - 5 V) \dots U_V \text{ DC}$
Voltage range for signal (1)		$-3 \text{ VDC} \dots (U_V - 15 \text{ V})$
Sensor connection	2 x (2-wire, 3-wire); A suitable field side connection module (e.g., 750-614) must also be used to connect other sensors.	
Input characteristic	low-side switching	
Input filter (digital)	0.2 ms	
Input current per channel for signal (0) typ.	7 mA	
Supply voltage (sensor)	24 VDC	
Supply voltage (field)	24 VDC (-15 ... +20 %); via power jumper contacts (power supply via blade contact; transmission via spring contact)	
Current consumption (5 V system supply)	5 mA	
Input data width (internal) max.	4 bits	
Isolation	500 V system/field	
Ambient temperature (operation)	0 ... +55 °C	
Dimensions W x H x D	(12 x 100 x 69.8) mm	
Approvals	CE, OrdLoc/HazLoc, ATEX/IECEX	
For data sheet and additional information, see:	wago.com/750-409	wago.com/753-409
Accessories	Item no.	Item no.
Plug	-	753-110

Digital input ▶ 24 VDC ▶ low-side switching ▶ 0.2 ms



750-1423

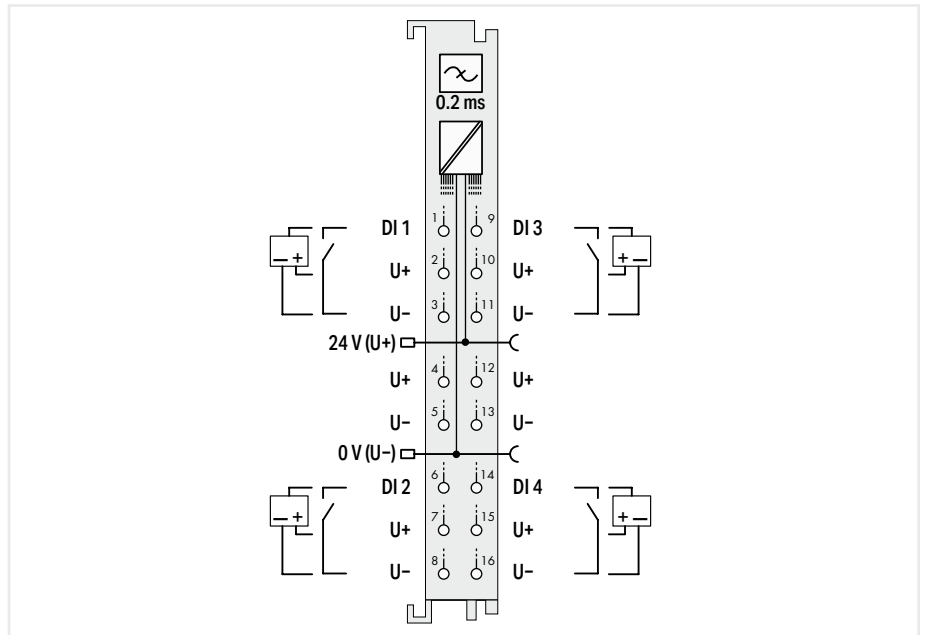

Item description	4-Channel Digital Input; 24 VDC; 0.2 ms; Low-side switching; 3-wire connection
Version	Standard with 16 connectors
Item no.	750-1423
Order Text	4DI; 24 VDC; 0.2ms; LSS; 3-wire

Technical data

Pluggable connector	fixed
Number of digital inputs	4
Signal type	Digital
Signal type (voltage)	24 VDC
Voltage range for signal (0)	$(U_V - 5 V) \dots U_V, DC$
Voltage range for signal (1)	$-3 VDC \dots (U_V - 15 V)$
Sensor connection	4 x (3-wire)
Input characteristic	low-side switching
Input filter (digital)	0.2 ms
Input current per channel for signal (1) typ.	-0.6 mA
Input current per channel for signal (0) typ.	2.5 mA
Supply voltage (sensor)	24 VDC
Supply voltage (field)	24 VDC (-25 ... +30 %); via power jumper contacts (power supply via blade contact; transmission via spring contact)
Current consumption (5 V system supply)	7 mA
Input data width (internal) max.	4 bits
Isolation	500 V system/field
Ambient temperature (operation)	0 ... +55 °C
Dimensions W x H x D	(12 x 100 x 69) mm
Approvals	CE; Marine; OrdLoc/HazLoc; ATEX/IECEx

For data sheet and additional information, see:

wago.com/750-1423

Digital input ▶ 24 VDC ▶ low-side switching ▶ 0.2 ms



750-437

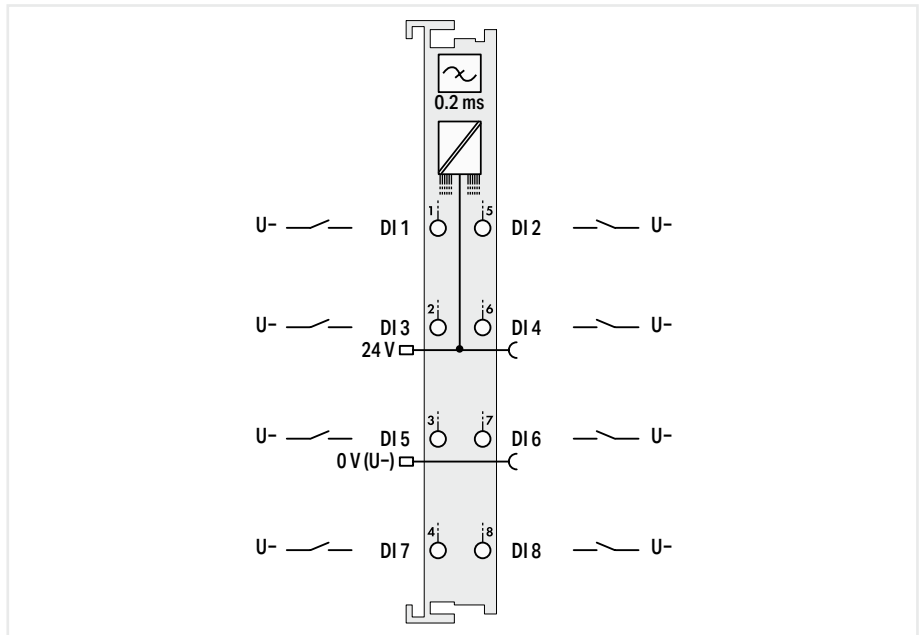

Item description	8-Channel Digital Input; 24 VDC; 0.2 ms; Low-side switching	
Version	Standard	pluggable (delivery without connector)
Item no.	750-437	753-437
Order Text	8DI; 24 VDC; 0.2ms; LSS	8DI; 24 VDC; 0.2ms; LSS

Technical data	fixed	pluggable
Pluggable connector		
Number of digital inputs		8
Signal type		Digital
Signal type (voltage)		24 VDC
Voltage range for signal (0)		15 ... 30 VDC
Voltage range for signal (1)		-3 ... +5 VDC
Sensor connection		8 x (1-wire)
Input characteristic		low-side switching
Input filter (digital)		0.2 ms
Input current per channel for signal (0) typ.		2.8 mA
Supply voltage (field)	24 VDC (-25 ... +30 %); via power jumper contacts (power supply via blade contact; transmission via spring contact)	
Current consumption (5 V system supply)		13 mA
Input data width (internal) max.		8 bits
Isolation		500 V system/field
Ambient temperature (operation)		0 ... +55 °C
Dimensions W x H x D	(12 x 100 x 67.8) mm	(12 x 100 x 69) mm
Approvals	CE; Marine; OrdLoc/HazLoc; ATEX/IECEX	
For data sheet and additional information, see:	wago.com/750-437	wago.com/753-437
Accessories	Item no.	Item no.
Plug	-	753-110

7.2

Digital input ▶ 24 VDC ▶ low-side switching ▶ 0.2 ms



750-1418

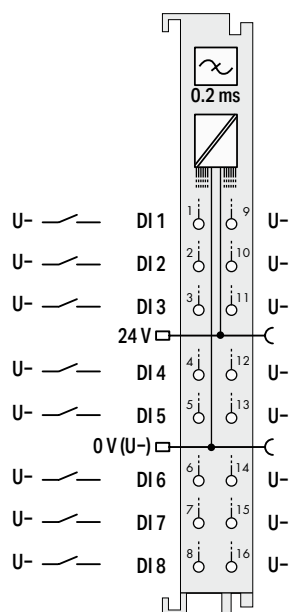

Item description	8-Channel Digital Input; 24 VDC; 0.2 ms; Low-side switching; 2-wire connection
Version	Standard with 16 connectors
Item no.	750-1418
Order Text	8DI; 24 VDC; 0.2ms; LSS; 2-wire

Technical data

Pluggable connector	fixed
Number of digital inputs	8
Signal type	Digital
Signal type (voltage)	24 VDC
Voltage range for signal (0)	$(U_V - 5 V) \dots U_V, DC$
Voltage range for signal (1)	$-3 VDC \dots (U_V - 15 V)$
Sensor connection	8 x (2-wire)
Input characteristic	low-side switching
Input filter (digital)	0.2 ms
Input current per channel for signal (1) typ.	-0.6 mA
Input current per channel for signal (0) typ.	2.4 mA
Supply voltage (sensor)	24 VDC
Supply voltage (field)	24 VDC (-25 ... +30 %); via power jumper contacts (power supply via blade contact; transmission via spring contact)
Current consumption (5 V system supply)	12 mA
Input data width (internal) max.	8 bits
Isolation	500 V system/field
Ambient temperature (operation)	0 ... +55 °C
Dimensions W x H x D	(12 x 100 x 69) mm
Approvals	CE; Marine; OrdLoc/HazLoc; ATEX/IECEX

For data sheet and additional information, see:

wago.com/750-1418

Digital input ▶ 24 VDC; proximity sensor ▶ high-side switching ▶ 3 ms



750-410

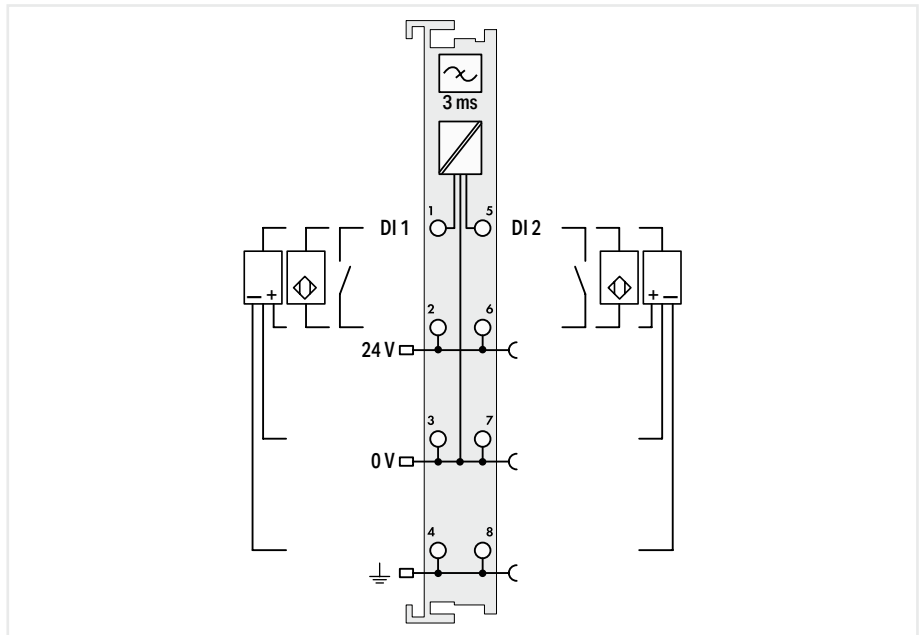

Item description	2-Channel Digital Input; 24 VDC; 3 ms; Proximity sensor	
Version	Standard	pluggable (delivery without connector)
Item no.	750-410	753-410
Order Text	2DI; 24 VDC; 3ms; Proxi Sensor	2DI; 24 VDC; 3ms; Proxi Sensor

Technical data

	fixed	pluggable
Pluggable connector		
Number of digital inputs		2
Signal type		Digital
Signal type (voltage)		24 VDC
Voltage range for signal (0)		-3 ... +5 VDC
Voltage range for signal (1)		15 ... 30 VDC
Sensor connection		2 x (2-wire, 3-wire, 4-wire); 2-wire proximity sensor
Input characteristic		high-side switching
Input filter (digital)		3 ms
Input current per channel for signal (1) typ.		8 mA
Supply voltage (sensor)		24 VDC
Supply voltage (field)		24 VDC (-25 ... +30 %); via power jumper contacts (power supply via blade contact; transmission via spring contact)
Current consumption (5 V system supply)		2.5 mA
Input data width (internal) max.		2 bits
Isolation		500 V system/field
Ambient temperature (operation)		0 ... +55 °C
Dimensions W x H x D		(12 x 100 x 69.8) mm
Approvals	CE; [Symbol] Marine; [Symbol] OrdLoc/HazLoc; [Symbol] ATEX/IECEx	
For data sheet and additional information, see:	wago.com/750-410	wago.com/753-410
Accessories	Item no.	Item no.
Plug	-	753-110

Digital input ▶ 24 VDC; proximity sensor ▶ high-side switching ▶ 0.2 ms



750-411

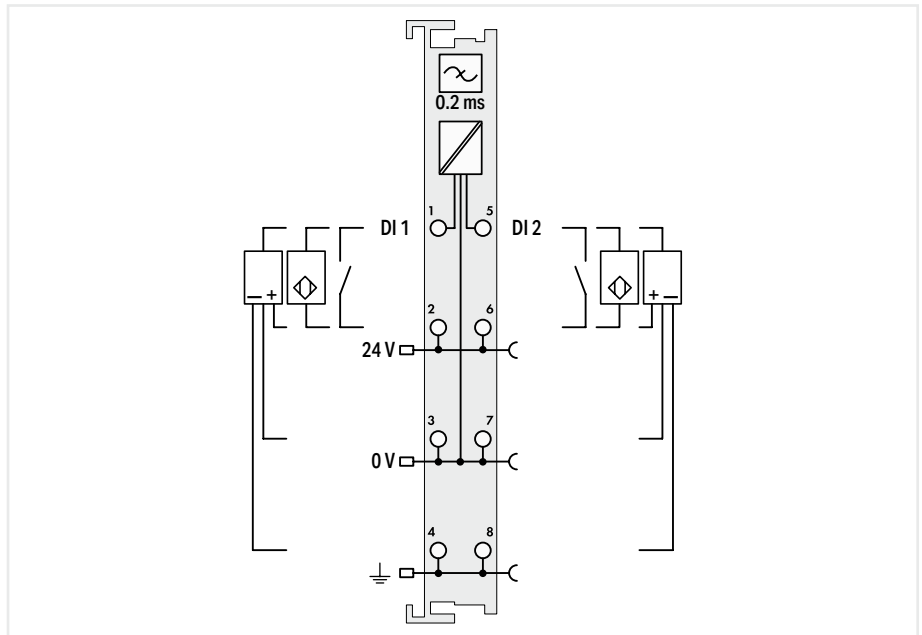

Item description	2-Channel Digital Input; 24 VDC; 0.2 ms; Proximity sensor	
Version	Standard	pluggable (delivery without connector)
Item no.	750-411	753-411
Order Text	2DI; 24 VDC; 0.2ms; Proxi Sensor	2DI; 24 VDC; 0.2ms; Proxi Sensor

Technical data	fixed	pluggable
Pluggable connector		
Number of digital inputs		2
Signal type		Digital
Signal type (voltage)		24 VDC
Voltage range for signal (0)		-3 ... +5 VDC
Voltage range for signal (1)		15 ... 30 VDC
Sensor connection		2 x (2-wire, 3-wire, 4-wire); 2-wire proximity sensor
Input characteristic		high-side switching
Input filter (digital)		0.2 ms
Input current per channel for signal (1) typ.		8 mA
Supply voltage (sensor)		24 VDC
Supply voltage (field)		24 VDC (-25 ... +30 %); via power jumper contacts (power supply via blade contact; transmission via spring contact)
Current consumption (5 V system supply)		2.5 mA
Input data width (internal) max.		2 bits
Isolation		500 V system/field
Ambient temperature (operation)		0 ... +55 °C
Dimensions W x H x D		(12 x 100 x 69.8) mm
Approvals	CE; Marine; OrdLoc/HazLoc; ATEX/IECEx	
For data sheet and additional information, see:	wago.com/750-411	wago.com/753-411
Accessories	Item no.	Item no.
Plug	-	753-110

Digital input ► NAMUR ► high-side switching ► 3 ms



750-425

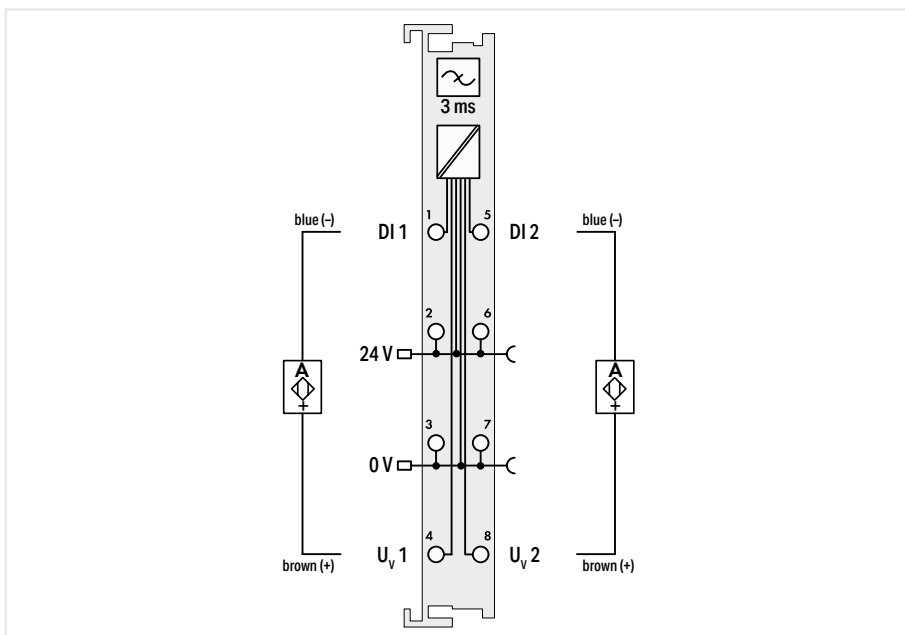

Diagnostics	Short circuit, wire break	
Item description	2-Channel Digital Input; NAMUR	
Version	Standard	pluggable (delivery without connector)
Item no.	750-425	753-425
Order Text	2DI; NAMUR	2DI; NAMUR

Technical data

	fixed	pluggable
Pluggable connector		
Number of digital inputs		2
Signal type		NAMUR
Signal current (0) NAMUR		≤1.2 mA
Signal current (1) NAMUR		≥2.1 mA
Sensor connection		2 x (2-wire)
Input characteristic		high-side switching
Input filter (digital)		3 ms
Protection against incorrect wiring		Short circuit monitoring: > 6.5 mA; Wire break monitoring: < 0.2 mA
Open-circuit voltage		8.2 V
Diagnostics		Short circuit, wire break
Supply voltage (sensor)		8.2 VDC; short-circuit-protected, each channel supplied separately
Supply voltage (field)		24 VDC (-25 ... +30 %); via power jumper contacts (power supply via blade contact; transmission via spring contact)
Current consumption (5 V system supply)		5 mA
Data width		4-bit input: 2-bit data, 2-bit error (short circuit/wire break)
Input data width (internal) max.		4 bits
Isolation		500 V system/field
Ambient temperature (operation)		0 ... +55 °C
Dimensions W x H x D		(12 x 100 x 69.8) mm
Approvals		CE; Marine; OrdLoc/HazLoc; ATEX/IECEx
For data sheet and additional information, see:	wago.com/750-425	wago.com/753-425

Accessories	Item no.	Item no.
--------------------	-----------------	-----------------

Plug	-	753-110
------	---	---------

This digital input module receives control signals from NAMUR proximity sensors (per DIN EN 60947-5-6) from the field side. Each channel of the sensors is supplied with a short-circuit-protected voltage of 8.2 V. A short circuit or a line break is indicated in the process image (1 bit) and via the red LED. The green LED indicates the input status:

- Signal current (0): LED off
- Signal current (1): LED on

Field and system levels are electrically isolated.

Digital input ► Current loop (intruder detection)



750-424

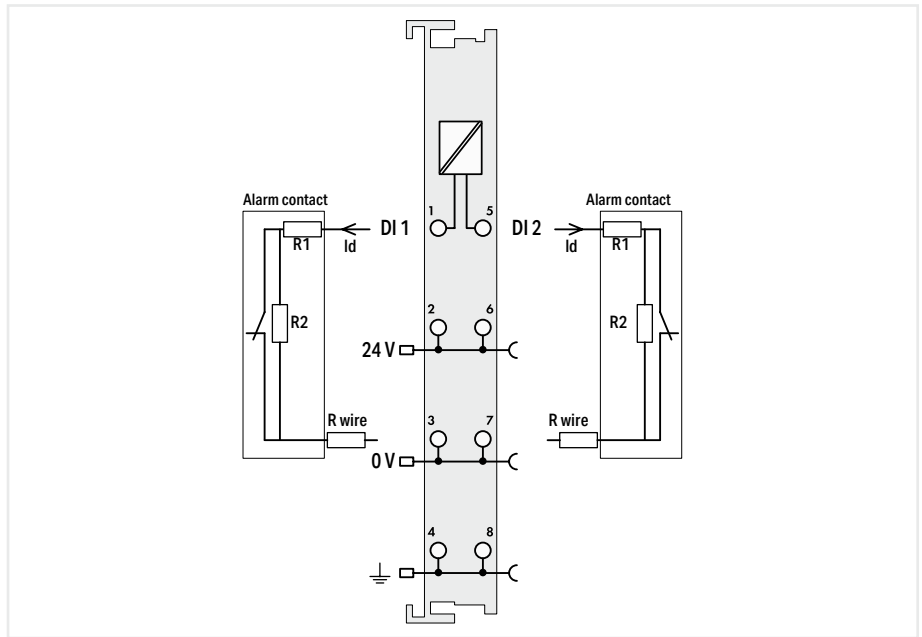

Item description
Version
Item no.
Order Text

2-Channel Digital Input; Intruder detection	
Standard	pluggable (delivery without connector)
750-424	753-424
2DI; Intruder Detection	2DI; Intruder Detection

Technical data	
Pluggable connector	
Number of digital inputs	2
Signal type	Current loop (intruder detection)
Sensor connection	2 x (2-wire)
Specific sensor properties	Alarm contact: R1 = 1.5 kΩ (±5 %); R2 = 2.2 kΩ (±5 %); Conductor resistance (R wire): 200 Ω (max.)
Output current per channel	0.001 A
Current consumption, field supply (module with no external load)	16 mA
Supply voltage (sensor)	24 VDC
Supply voltage (field)	24 VDC (-25 ... +30 %); via power jumper contacts (power supply via blade contact; transmission via spring contact)
Current consumption (5 V system supply)	6 mA
Data width	4-bit input: 2-bit data, 2-bit error (short circuit/wire break)
Input data width (internal) max.	4 bits
Isolation	500 V system/field
Ambient temperature (operation)	0 ... +55 °C
Dimensions W x H x D	(12 x 100 x 69.8) mm
Approvals	CE; L; Marine; OrdLoc/HazLoc; ATEX/IECEx
For data sheet and additional information, see:	wago.com/750-424 wago.com/753-424

	fixed	pluggable
Number of digital inputs		2
Signal type		Current loop (intruder detection)
Sensor connection		2 x (2-wire)
Specific sensor properties		Alarm contact: R1 = 1.5 kΩ (±5 %); R2 = 2.2 kΩ (±5 %); Conductor resistance (R wire): 200 Ω (max.)
Output current per channel		0.001 A
Current consumption, field supply (module with no external load)		16 mA
Supply voltage (sensor)		24 VDC
Supply voltage (field)		24 VDC (-25 ... +30 %); via power jumper contacts (power supply via blade contact; transmission via spring contact)
Current consumption (5 V system supply)		6 mA
Data width		4-bit input: 2-bit data, 2-bit error (short circuit/wire break)
Input data width (internal) max.		4 bits
Isolation		500 V system/field
Ambient temperature (operation)		0 ... +55 °C
Dimensions W x H x D		(12 x 100 x 69.8) mm
Approvals		CE; L; Marine; OrdLoc/HazLoc; ATEX/IECEx
For data sheet and additional information, see:		wago.com/750-424 wago.com/753-424

Accessories
Plug

Item no.	-	753-110
----------	---	---------

This I/O module incorporates a current loop, which makes it possible to monitor alarm contacts (window contacts) with a fixed resistance ratio (R1, R2), for intruder detection. The module indicates the status of the connected contact via LEDs and status bits in the process image.

Digital input ▶ 24 VDC; pulse extension ▶ high-side switching ▶ 1 ms



750-422

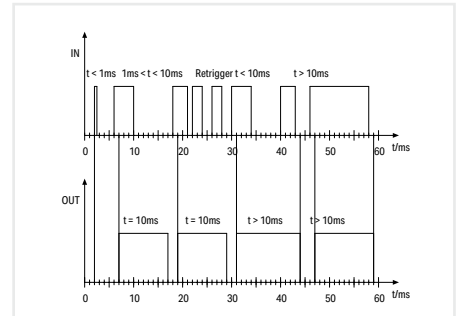
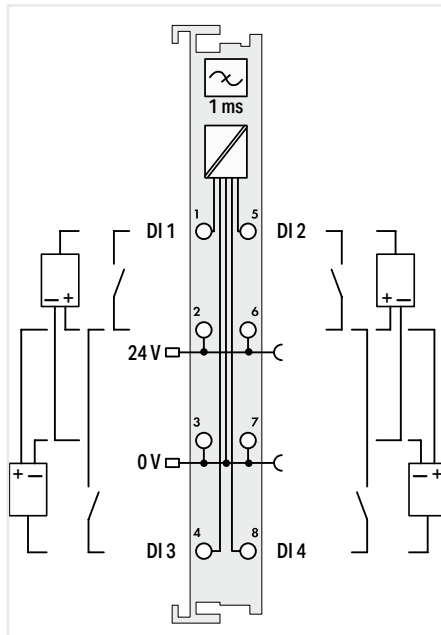

The I/O module extends input signals to at least 10 ms. Only signals ≥ 1 ms will be acquired. Input signals > 10 ms will not be extended (without fall delay). Field and system levels are electrically isolated.

Item description	4-Channel Digital Input; 24 VDC; Pulse extension	
Version	Standard	pluggable (delivery without connector)
Item no.	750-422	753-422
Order Text	4DI; 24 VDC; Pulse Extension	4DI; 24 VDC; Pulse Extension

Technical data

Pluggable connector	fixed	pluggable
Number of digital inputs	4	
Signal type	Digital	
Signal type (voltage)	24 VDC	
Voltage range for signal (0)	-3 ... +5 VDC	
Voltage range for signal (1)	15 ... 30 VDC	
Sensor connection	2 x (2-wire, 3-wire); A suitable field side connection module (e.g., 750-614) must also be used to connect other sensors.	
Input characteristic	high-side switching	
Input filter (digital)	1 ms	
Input current per channel for signal (1) typ.	4 mA	
Signal frequency (max.)	80 Hz	
Supply voltage (sensor)	24 VDC	
Supply voltage (field)	24 VDC (-15 ... +20 %); via power jumper contacts (power supply via blade contact; transmission via spring contact)	
Current consumption (5 V system supply)	9 mA	
Input data width (internal) max.	4 bits	
Isolation	500 V system/field	
Ambient temperature (operation)	0 ... +55 °C	
Dimensions W x H x D	(12 x 100 x 69.8) mm	
Approvals	CE, UL, OrdLoc/HazLoc, ATEX/IECEx	
For data sheet and additional information, see:	wago.com/750-422	wago.com/753-422
Accessories	Item no.	Item no.
Plug	-	753-110

7.2

Digital input ▶ 24 VAC/DC ▶ high-side switching ▶ 50 ms



750-423

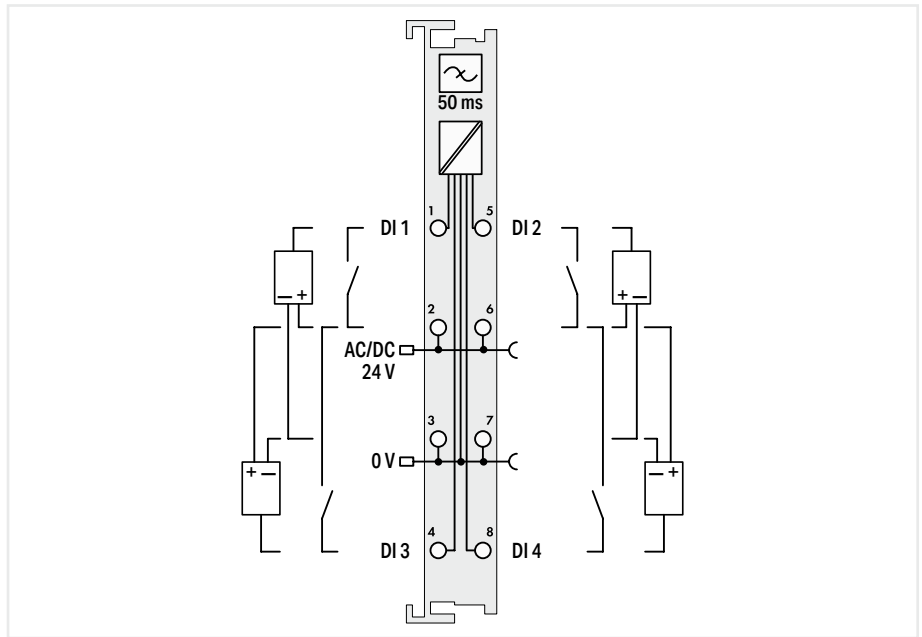

Item description
Version
Item no.
Order Text

4-Channel Digital Input; 24 V AC/DC; 50 ms	
Standard	pluggable (delivery without connector)
750-423	753-423
4DI; 24 VAC/VDC; 50ms	4DI; 24 VAC/VDC; 50ms

Technical data	
Pluggable connector	
Number of digital inputs	
Signal type	
Signal type (voltage)	
Voltage range for signal (0)	
Voltage range for signal (1)	
Input current (typ.)	
Sensor connection	
Input characteristic	
Input filter (digital)	
Supply voltage (sensor)	
Supply voltage (field)	
Current consumption (5 V system supply)	
Input data width (internal) max.	
Isolation	
Ambient temperature (operation)	
Dimensions W x H x D	
Approvals	
For data sheet and additional information, see:	
Accessories	

	fixed	pluggable
Number of digital inputs		4
Signal type		Digital
Signal type (voltage)		24 VAC/DC
Voltage range for signal (0)		-3 ... +5 VDC; 0 ... 5 VAC
Voltage range for signal (1)		11 ... 30 VDC; 10 ... 27 VAC
Input current (typ.)		7.5 mA (AC); 9.5 mA (DC)
Sensor connection	2 x (2-wire, 3-wire); A suitable field side connection module (e.g., 750-614) must also be used to connect other sensors.	
Input characteristic	high-side switching	
Input filter (digital)	50 ms	
Supply voltage (sensor)	24 VAC/DC	
Supply voltage (field)	24 VAC/DC (-15 ... +20 %); via power jumper contacts (power supply via blade contact; transmission via spring contact)	
Current consumption (5 V system supply)	10 mA	
Input data width (internal) max.	4 bits	
Isolation	500 V system/field	
Ambient temperature (operation)	0 ... +55 °C	
Dimensions W x H x D	(12 x 100 x 69.8) mm	
Approvals	CE; Marine; OrdLoc/HazLoc; ATEX/IECEx	
For data sheet and additional information, see:	wago.com/750-423	wago.com/753-423
Accessories	Item no.	Item no.
Plug	-	753-110

Notice: An additional supply module must be added for 24 VAC supply!

Digital input ▶ 24 VAC/DC ▶ high-side switching ▶ 20 ms



750-415

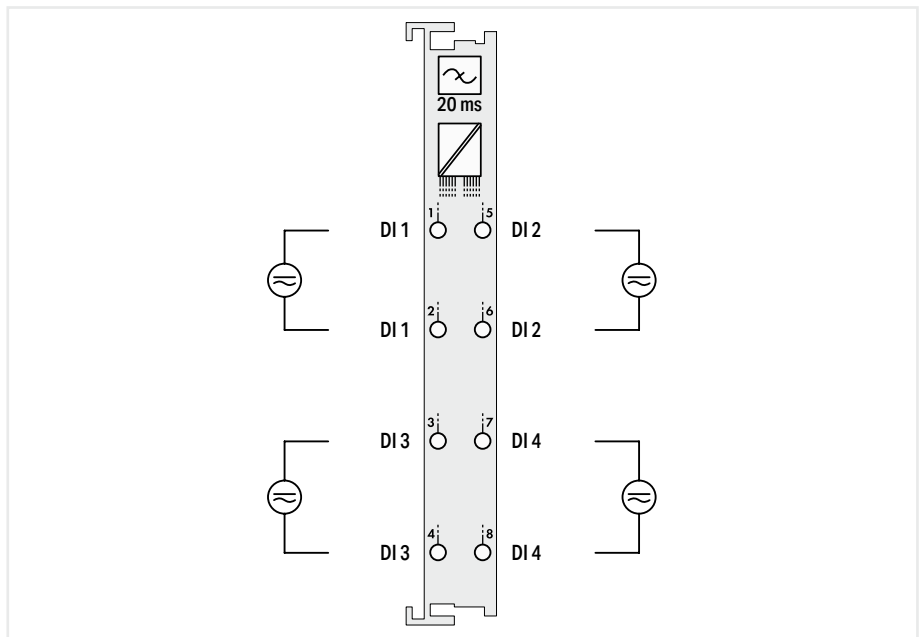

Item description	4-Channel Digital Input; 24 V AC/DC; 20 ms	
Version	Standard	pluggable (delivery without connector)
Item no.	750-415	753-415
Order Text	4DI; 24 VAC/VDC; 20ms	4DI; 24 VAC/VDC; 20ms

Technical data	fixed	pluggable
Pluggable connector		
Number of digital inputs		4
Signal type		Digital
Signal type (voltage)		24 VAC/DC
Voltage range for signal (0)		-3 ... +5 VDC; 0 ... 5 VAC
Voltage range for signal (1)		11 ... 30 VDC; 10 ... 27 VAC
Input current (typ.)		7.5 mA (AC); 9.5 mA (DC)
Sensor connection		4 x (2-wire)
Input characteristic		high-side switching
Input filter (digital)		20 ms
Current consumption (5 V system supply)		10 mA
Input data width (internal) max.		4 bits
Isolation		500 V system/field
Ambient temperature (operation)		0 ... +55 °C
Dimensions W x H x D		(12 x 100 x 69.8) mm
Approvals	CE; Marine; OrdLoc/HazLoc; ATEX/IECEX	
For data sheet and additional information, see:	wago.com/750-415	wago.com/753-415
Accessories	Item no.	Item no.
Plug	-	753-110

Digital input ▶ 42 VAC/DC ▶ high-side switching ▶ 20 ms



750-428

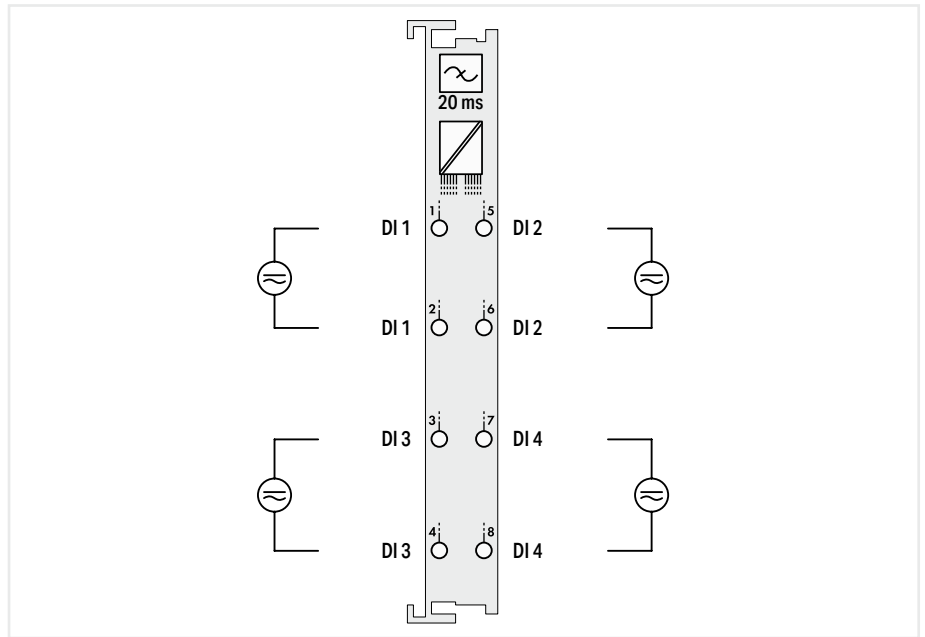

Item description
Version
Item no.
Order Text

4-Channel Digital Input; 42 VAC/VDC; 20 ms	
Standard	pluggable (delivery without connector)
750-428	753-428
4DI; 42 VAC/VDC; 20ms	4DI; 42 VAC/VDC; 20ms

Technical data	
Pluggable connector	
Number of digital inputs	
Signal type	
Signal type (voltage)	
Voltage range for signal (0)	
Voltage range for signal (1)	
Input current (typ.)	
Sensor connection	
Input characteristic	
Input filter (digital)	
Current consumption (5 V system supply)	
Input data width (internal) max.	
Isolation	
Ambient temperature (operation)	
Dimensions W x H x D	
Approvals	
For data sheet and additional information, see:	

	fixed	pluggable
		4
		Digital
		42 VAC/DC
		-3 ... +10 VDC; 0 ... 10 VAC
		30 ... 53 VDC; 30 ... 53 VAC
		3.6 mA (AC); 6.0 mA (DC)
		4 x (2-wire)
		high-side switching
		20 ms
		5 mA
		4 bits
		500 V system/field
		0 ... +55 °C
		(12 x 100 x 69.8) mm
	CE, OrdLoc/HazLoc; ATEX/IECEx	
	wago.com/750-428	wago.com/753-428

Accessories
Plug

Item no.		Item no.
	-	753-110

Digital input ▶ 48 VDC ▶ high-side switching ▶ 3 ms



750-412

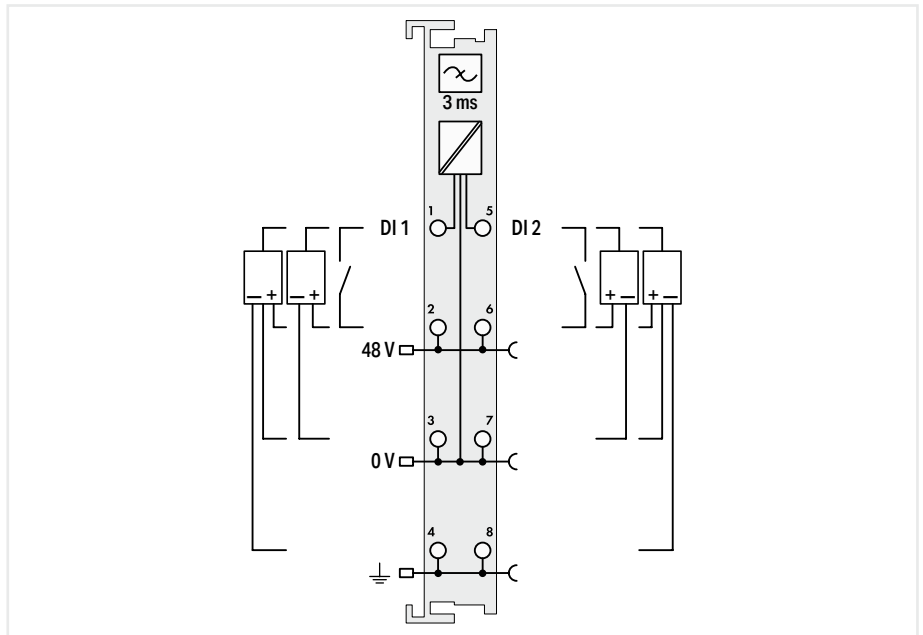

Item description	2-Channel Digital Input; 48 VDC; 3 ms	
Version	Standard	pluggable (delivery without connector)
Item no.	750-412	753-412
Order Text	2DI; 48 VDC; 3ms	2DI; 48 VDC; 3ms

Technical data

	fixed	pluggable
Pluggable connector		
Number of digital inputs		2
Signal type		Digital
Signal type (voltage)		48 VDC
Voltage range for signal (0)		-6 ... +10 VDC
Voltage range for signal (1)		34 ... 60 VDC
Sensor connection		2 x (2-wire, 3-wire, 4-wire)
Input characteristic		high-side switching
Input filter (digital)		3 ms
Input current per channel for signal (1) typ.		3.8 mA
Supply voltage (sensor)		48 VDC
Supply voltage (field)		48 VDC (-15 ... +20 %); via power jumper contacts (power supply via blade contact; transmission via spring contact)
Current consumption (5 V system supply)		2.5 mA
Input data width (internal) max.		2 bits
Isolation		500 V system/field
Ambient temperature (operation)		0 ... +55 °C
Dimensions W x H x D		(12 x 100 x 69.8) mm
Approvals	CE; OrdLoc/HazLoc; ATEX/IECEX	
For data sheet and additional information, see:	wago.com/750-412	wago.com/753-412
Accessories	Item no.	Item no.
Plug	-	753-110

Notice: An additional supply module must be added for 48 VDC supply!

Digital input ▶ 60 VDC ▶ high-side switching ▶ 3 ms



753-429

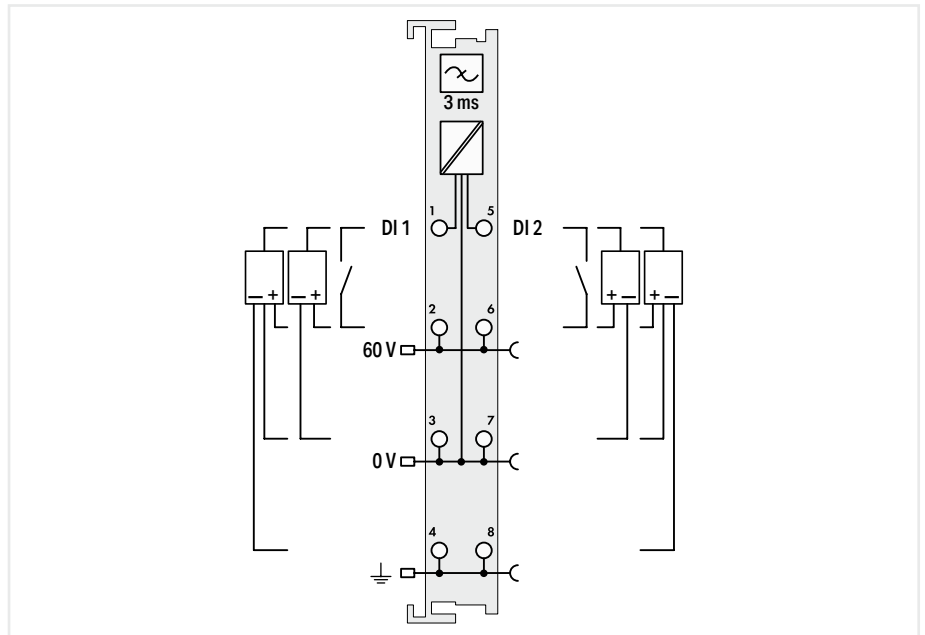

Item description	2-Channel Digital Input; 60 VDC; 3 ms
Version	pluggable (delivery without connector)
Item no.	753-429
Order Text	2DI; 60 VDC; 3ms
Technical data	
Pluggable connector	pluggable
Number of digital inputs	2
Signal type	Digital
Signal type (voltage)	60 VDC
Voltage range for signal (0)	-7.5 ... +12 VDC
Voltage range for signal (1)	44 ... 75 VDC
Sensor connection	2 x (2-wire, 3-wire, 4-wire)
Input characteristic	high-side switching
Input filter (digital)	3 ms
Input current per channel for signal (1) typ.	2.9 mA
Supply voltage (sensor)	60 VDC
Supply voltage (field)	60 VDC (-20 ... +25 %); via power jumper contacts (power supply via blade contact; transmission via spring contact)
Current consumption (5 V system supply)	2.5 mA
Input data width (internal) max.	2 bits
Isolation	500 V system/field
Ambient temperature (operation)	0 ... +55 °C
Dimensions W x H x D	(12 x 100 x 69.8) mm
Approvals	CE, IEC, OrdLoc/HazLoc, ATEX/IECEX
For data sheet and additional information, see:	wago.com/753-429
Accessories	Item no.
Plug	753-110

Notice: An additional supply module must be added for 60 VDC supply!

Digital input ▶ 110 VDC ▶ high-side/low-side switching, configurable ▶ 3 ms



750-427

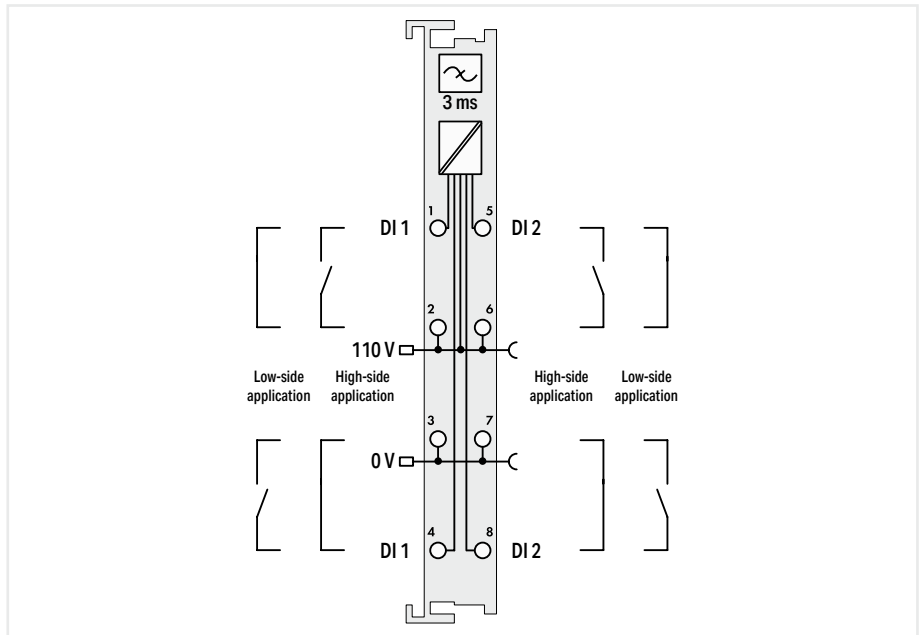

Item description	2-Channel Digital Input; 110 VDC
Version	Standard
Item no.	750-427
Order Text	2DI; 110 VDC

Standard	pluggable (delivery without connector)
750-427	753-427
2DI; 110 VDC	2DI; 110 VDC

Technical data	
Pluggable connector	fixed
Number of digital inputs	2
Signal type	Digital
Signal type (voltage)	110 VDC
Voltage range for signal (0)	-14 ... +50 VDC
Voltage range for signal (1)	70 ... 143 VDC
Sensor connection	2 x (2-wire)
Input characteristic	high-side/low-side switching, configurable
Input filter (digital)	3 ms
Input current per channel for signal (1) typ.	2.5 mA
Supply voltage (sensor)	110 VDC
Supply voltage (field)	110 VDC (-20 ... +25 %); via power jumper contacts (power supply via blade contact; transmission via spring contact)
Current consumption (5 V system supply)	2.5 mA
Input data width (internal) max.	2 bits
Isolation	1500 V (system/field)
Ambient temperature (operation)	0 ... +55 °C
Dimensions W x H x D	(12 x 100 x 69.8) mm
Approvals	CE; OrdLoc/HazLoc; ATEX/IECEx
For data sheet and additional information, see:	wago.com/750-427

Standard	pluggable (delivery without connector)
750-427	753-427
2DI; 110 VDC	2DI; 110 VDC
fixed	pluggable
2	2
Digital	Digital
110 VDC	110 VDC
-14 ... +50 VDC	-14 ... +50 VDC
70 ... 143 VDC	70 ... 143 VDC
2 x (2-wire)	2 x (2-wire)
high-side/low-side switching, configurable	high-side/low-side switching, configurable
3 ms	3 ms
2.5 mA	2.5 mA
110 VDC	110 VDC
110 VDC (-20 ... +25 %); via power jumper contacts (power supply via blade contact; transmission via spring contact)	110 VDC (-20 ... +25 %); via power jumper contacts (power supply via blade contact; transmission via spring contact)
2.5 mA	2.5 mA
2 bits	2 bits
1500 V (system/field)	1500 V (system/field)
0 ... +55 °C	0 ... +55 °C
(12 x 100 x 69.8) mm	(12 x 100 x 69.8) mm
CE; OrdLoc/HazLoc; ATEX/IECEx	CE; OrdLoc/HazLoc; ATEX/IECEx
wago.com/750-427	wago.com/753-427

Accessories	Item no.
Plug	753-110

Item no.	Item no.
-	753-110

Notice: An additional supply module must be added for 110 VDC supply!

7.2

Digital input ► 220 VDC ► high-side switching ► 3 ms



750-407

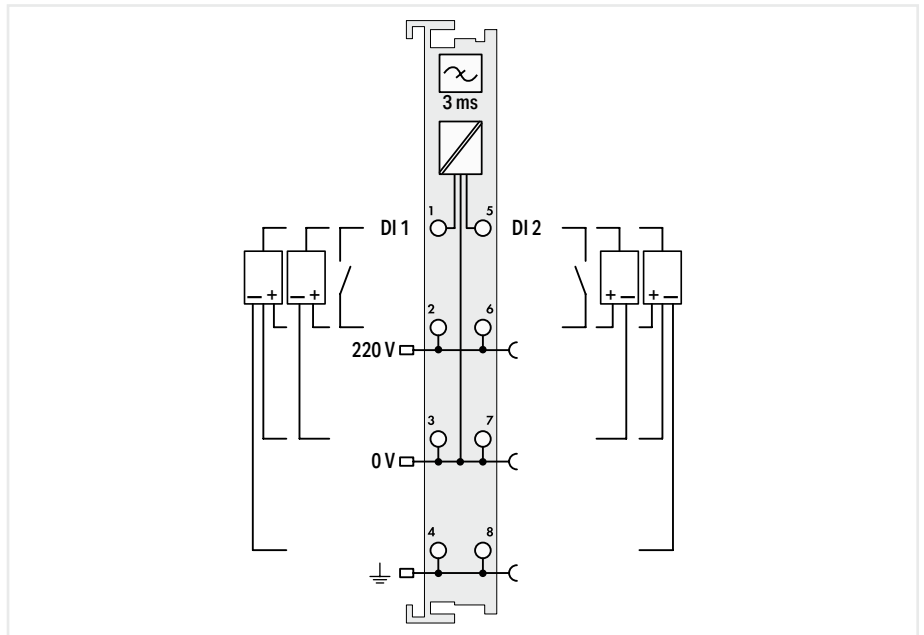

Item description	2-Channel Digital Input; 220 VDC	
Version	Standard	
Item no.	750-407	
Order Text	2DI; 220 VDC	
Technical data		
Pluggable connector		fixed
Number of digital inputs		2
Signal type		Digital
Signal type (voltage)		220 VDC
Voltage range for signal (0)		-3 ... +100 VDC
Voltage range for signal (1)		160 ... 286 VDC
Sensor connection		2 x (2-wire, 3-wire, 4-wire)
Input characteristic		high-side switching
Input filter (digital)		3 ms
Input current per channel for signal (1) typ.		1.2 mA
Supply voltage (sensor)		220 VDC
Supply voltage (field)		220 VDC (-20 ... +25 %); via power jumper contacts (power supply via blade contact; transmission via spring contact)
Current consumption (5 V system supply)		5 mA
Input data width (internal) max.		2 bits
Isolation		2500 V system/field
Ambient temperature (operation)		0 ... +55 °C
Dimensions W x H x D		(12 x 100 x 69.8) mm
Approvals		CE,
For data sheet and additional information, see:		wago.com/750-407

Notice: An additional supply module must be added for 220 VDC supply!

Digital input ▶ 120 VAC ▶ high-side switching ▶ 10 ms



750-406

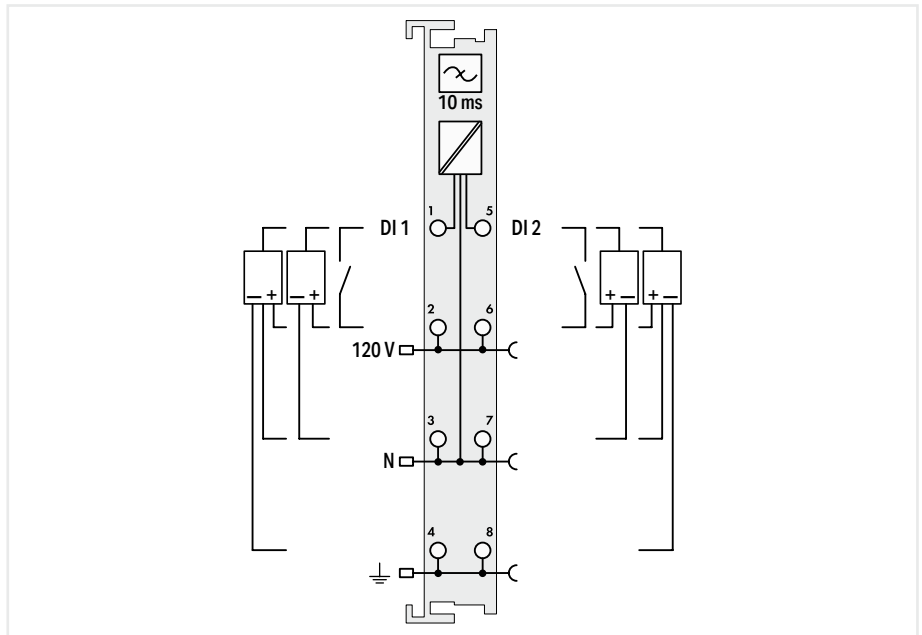

Item description	2-Channel Digital Input; 120 VAC	
Version	Standard	pluggable (delivery without connector)
Item no.	750-406	753-406
Order Text	2DI; 120 VAC	2DI; 120 VAC

Technical data	fixed	pluggable
Pluggable connector		
Number of digital inputs		2
Signal type		Digital
Signal type (voltage)		120 VAC
Voltage range for signal (0)		0 ... 20 VAC
Voltage range for signal (1)		79 VAC ... 1.1 x U _N
Sensor connection		2 x (2-wire, 3-wire, 4-wire)
Input characteristic		high-side switching
Input filter (digital)		10 ms
Input current per channel for signal (1) typ.		4.5 mA
Signal frequency (min.)		45 Hz
Signal frequency (max.)		65 Hz
Supply voltage (sensor)		120 VAC
Supply voltage (field)	120 VAC (-15 ... +20 %); via power jumper contacts (power supply via blade contact; transmission via spring contact)	
Current consumption (5 V system supply)		2 mA
Input data width (internal) max.		2 bits
Isolation		1500 V (system/field)
Ambient temperature (operation)		0 ... +55 °C
Dimensions W x H x D		(12 x 100 x 69.8) mm
Approvals	CE; Marine; OrdLoc/HazLoc; ATEX/IECEX	

For data sheet and additional information, see:	wago.com/750-406	wago.com/753-406
Accessories	Item no.	Item no.
Plug	-	753-110

Notice: An additional supply module must be added for 120 VAC supply!

7.2

Digital input ▶ 230 VAC ▶ high-side switching ▶ 10 ms



750-405

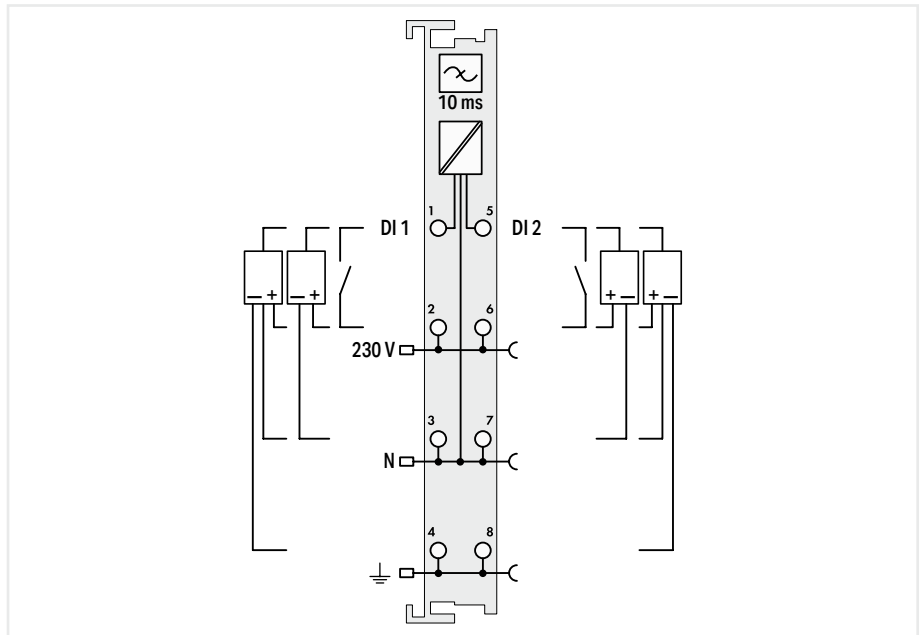

Item description	2-Channel Digital Input; 230 VAC
Version	Standard
Item no.	750-405
Order Text	2DI; 230 VAC

Standard	pluggable (delivery without connector)
750-405	753-405
2DI; 230 VAC	2DI; 230 VAC

Technical data

Pluggable connector	fixed	pluggable
Number of digital inputs	2	
Signal type	Digital	
Signal type (voltage)	230 VAC	
Voltage range for signal (0)	0 ... 40 VAC	
Voltage range for signal (1)	164 VAC ... 1.1 x U _N	
Sensor connection	2 x (2-wire, 3-wire, 4-wire)	
Input characteristic	high-side switching	
Input filter (digital)	10 ms	
Input current per channel for signal (1) typ.	6.5 mA	
Signal frequency (min.)	45 Hz	
Signal frequency (max.)	65 Hz	
Supply voltage (sensor)	230 VAC	
Supply voltage (field)	230 VAC (-15 ... +20 %); via power jumper contacts (power supply via blade contact; transmission via spring contact)	
Current consumption (5 V system supply)	2 mA	
Input data width (internal) max.	2 bits	
Isolation	1500 V (system/field)	
Ambient temperature (operation)	0 ... +55 °C	
Dimensions W x H x D	(12 x 100 x 69.8) mm	
Approvals	CE, L, Marine, OrdLoc/HazLoc, ATEX/IECEx	

For data sheet and additional information, see:	wago.com/750-405	wago.com/753-405
---	------------------	------------------

Accessories	Item no.	Item no.
Plug	-	753-110

Item no.	Item no.
-	753-110

Notice: An additional supply module must be added for 230 VAC supply!

Digital input ▶ 120/230 VAC ▶ high-side switching ▶ 10 ms



753-440

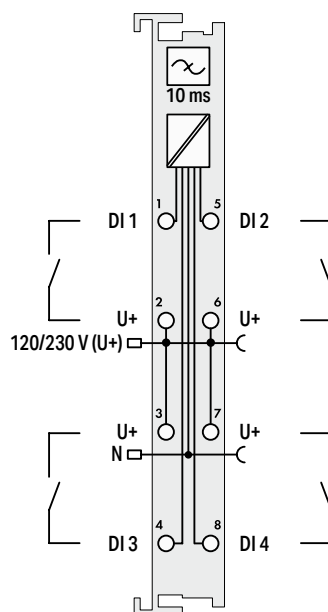

Item description	4-Channel Digital Input; 120/230 VAC
Version	pluggable (delivery without connector)
Item no.	753-440
Order Text	4DI; 120/230 VAC
Technical data	
Pluggable connector	pluggable
Number of digital inputs	4
Signal type	Digital
Signal type (voltage)	120 VAC
Voltage range for signal (0)	0 ... 40 VAC
Voltage range for signal (1)	79 ... 230 VAC (-15 ... +10 %)
Sensor connection	4 x (2-wire)
Input characteristic	high-side switching
Input filter (digital)	10 ms
Input current at specific input voltage	2.3 mA at 120 V
Input current at specific input voltage (2)	4.7 mA bei 230 V
Signal frequency (min.)	45 Hz
Signal frequency (max.)	65 Hz
Protection against incorrect wiring	Overvoltage protection (275 V) via varistor
Supply voltage (sensor)	230 VAC
Supply voltage (field)	230 VAC; via power jumper contacts (power supply via blade contact; transmission via spring contact)
Current consumption (5 V system supply)	15 mA
Input data width (internal) max.	4 bits
Isolation	1500 V (system/field)
Ambient temperature (operation)	0 ... +55 °C
Dimensions W x H x D	(12 x 100 x 69.8) mm
Approvals	CE; OrdLoc/HazLoc; ATEX/IECEx
For data sheet and additional information, see:	wago.com/753-440
Accessories	Item no.
Plug	753-110

Notice: An additional supply module must be added for 120/230 VAC supply!

Digital input ▶ PTC, thermistor per DIN 44081/44082 ▶ 100 ms



750-1425

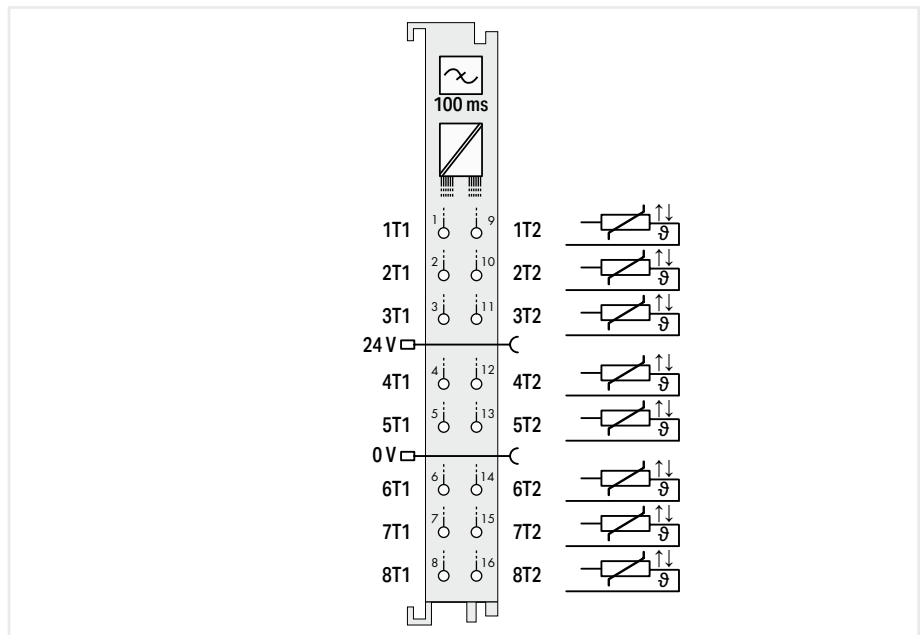

Item description	8-Channel Digital Input; PTC
Version	Standard with 16 connectors
Item no.	750-1425
Order Text	8DI; PTC

Technical data

Pluggable connector	fixed
Number of digital inputs	8
Signal type	PTC, thermistor per DIN 44081/44082
Sensor connection	8 x (2-wire)
Specific sensor properties	Sensor voltage: $\leq 2.5 \text{ V} / \leq 7.5 \text{ V}$ (based on resistance value); Number of PTCs per channel: max. 6 PTCs in series; Operating value (status bit "1" to "0"): $R \geq 3 \text{ k}\Omega$; Return value (status bit "0" to "1"): $\leq 1.5 \text{ k}\Omega$; Hysteresis: $R = 1.5 \text{ k}\Omega$; Wire break value: $R \geq 8 \text{ k}\Omega$; Short circuit value: $R \leq 20 \Omega$
Input filter (digital)	100 ms
Output current per channel	0.001 A
Supply voltage (field)	24 VDC (-25 ... +30 %); via power jumper contacts (power supply via blade contact; transmission via spring contact)
Current consumption (5 V system supply)	52 mA
Data width	16-bit input: 8-bit data, 8-bit error (short circuit/wire break)
Input data width (internal) max.	16 bits
Isolation	500 V system/field
Ambient temperature (operation)	0 ... +55 °C
Dimensions W x H x D	(12 x 100 x 69) mm
Approvals	CE; Marine; OrdLoc/HazLoc; ATEX/IECEX
For data sheet and additional information, see:	wago.com/750-1425

The PTC module is used to connect PTC thermistors according to DIN 44081 and DIN 44082 for thermal monitoring (overload protection) of motors, machinery, bearings, etc. Up to six PTC thermistors can be connected in series per channel. If the nominal response temperature (θ_{nat}) is exceeded, a bit is set in the module's input process image. In addition, wire breaks and short circuits are monitored for each channel. If an error occurs, a bit is also set in the input process image. The module features one green and one red status LED per channel to indicate excessive temperatures or wiring errors.

Digital Output Modules



Housing Design (750 Series)

Dimensions W x H x D	Housing with 4 LEDs: 12 x 100 x 69.8 mm Housing with 8 LEDs: 12 x 100 x 67.8 mm
Depth from upper edge of DIN-rail	Housing with 4 LEDs: 62.6 mm Housing with 8 LEDs: 60.6 mm
Connection technology	CAGE CLAMP®
Conductor cross-section	0.08 ... 2.5 mm ² / 28 ... 14 AWG
Strip length	8 ... 9 mm / 0.33 inch

Housing Design (753 Series)

Dimensions W x H x D	Housing with 4 LEDs: 12 x 100 x 69.8 mm Housing with 8 LEDs: 12 x 100 x 69 mm
Depth from upper edge of DIN-rail	Housing with 4 LEDs: 62.6 mm Housing with 8 LEDs: 61.8 mm
Connection technology	CAGE CLAMP®
Conductor cross-section	0.08 ... 2.5 mm ² / 28 ... 14 AWG
Strip length	9 ... 10 mm / 0.37 inch

Specialty Housing (750 Series)

Dimensions W x H x D	24 x 100 x 67.8 mm
Depth from upper edge of DIN-rail	60.6 mm

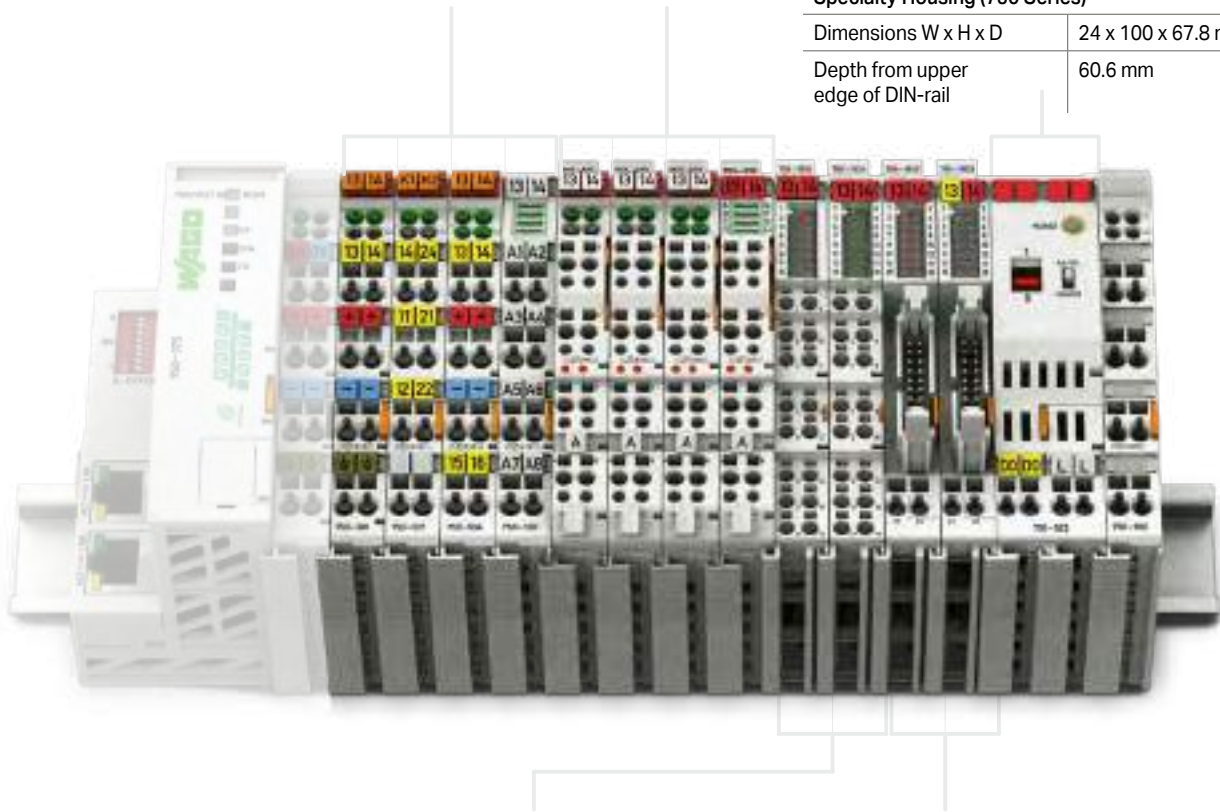

Housing Design (750 Series), with Push-in CAGE CLAMP® Connections (up to 16 connection points)

Dimensions W x H x D	12 x 100 x 69 mm
Depth from upper edge of DIN-rail	61.8 mm
Connection technology	Push-in CAGE CLAMP®
Conductor cross-section	Solid: 0.08 ... 1.5 mm ² / 28 ... 16 AWG Fine-stranded: 0.25 ... 1.5 mm ² / 22 ... 16 AWG
Strip length	8 ... 9 mm / 0.33 inch

Housing Design (750 Series), with Ribbon Cable Connection

Dimensions W x H x D	12 x 100 x 74.1 mm
Depth from upper edge of DIN-rail	66.9 mm
Connection technology	20-pole male connector + 2 x CAGE CLAMP®
Conductor cross-section	0.08 ... 2.5 mm ² / 28 ... 14 AWG
Strip length	8 ... 9 mm / 0.33 inch



I/O System –
750 XTR Series



I/O System – 750 and 753 Series, Digital Output Modules

Contents

Function	1-Channel DO	2-Channel DO	4-Channel DO	8-Channel DO	8-Channel DIO	16-Channel DO	Description	Item Number			Page	
								Standard	Extended Temperature	Pluggable		
5 VDC			■				4-Channel Digital Output; 5 VDC; 20 mA	750-519			278	
5/12 VDC				■			8-Channel Digital Output; 12 VDC; 1 A	750-534		753-534	279	
24 VDC	■						2-Channel Digital Output; 24 VDC; 0.5 A	750-501		753-501	280	
	■						2-Channel Digital Output; 24 VDC; 0.5 A; Interference-Free	750-501/000-800		753-501/000-800	280	
	■						2-Channel Digital Output; 24 VDC; 0.5 A; Diagnostics	750-506		753-506	281	
	■						2-Channel Digital Output; 24 VDC; 0.5 A; Interference-Free; Diagnostics	750-506/000-800			281	
	■						2-Channel Digital Output; 24 VDC; 2.0 A	750-502		753-502	282	
	■						2-Channel Digital Output; 24 VDC; 2.0 A; Interference-Free	750-502/000-800		753-502/000-800	282	
	■						2-Channel Digital Output; 24 VDC; 2.0 A; Diagnostics	750-508*		753-508	283	
	■						2-Channel Digital Output; 24 VDC; 2.0 A; Interference-Free; Diagnostics	750-508/000-800			283	
		■						4-Channel Digital Output; 24 VDC; 0.5 A	750-504	750-504/025-000	753-504	284
		■						4-Channel Digital Output; 24 VDC; 0.5 A; Interference-Free	750-504/000-800	750-504/025-800		284
		■						4-Channel Digital Output; 24 VDC; 0.5 A; 2-Wire Connection	750-531		753-531	285
		■						4-Channel Digital Output; 24 VDC; 0.5 A; 2-Wire Connection; Interference-Free	750-531/000-800		753-531/000-800	285
		■						4-Channel Digital Output; 24 VDC; 0.5 A; Diagnostics	750-532			286
		■						4-Channel Digital Output; 24 VDC; 0.5 A; Low-Side Switching	750-516		753-516	287
			■					8-Channel Digital Output; 24 VDC; 0.5 A	750-530	750-530/025-000	753-530	288
			■					8-Channel Digital Output; 24 VDC; 0.5 A; Diagnostics	750-537*		753-537	289
			■					8-Channel Digital Output; 24 VDC; 0.5 A; 2-Wire Connection	750-1515*			290
			■					8-Channel Digital Output; 24 VDC; 0.5 A; Low-Side Switching	750-536		753-536	291
			■					8-Channel Digital Output; 24 VDC; 0.5 A; Low-Side Switching; 2-Wire Connection	750-1516*			292
					■			16-Channel Digital Output; 24 VDC; 0.5 A	750-1504			293
				■			16-Channel Digital Output; 24 VDC; 0.5 A; Ribbon Cable	750-1500			294	
				■			8-Channel Digital Input/Output; 24 VDC; 0.5 A	750-1506			295	
				■			8-Channel Digital Input/Output; 24 VDC; 0.5 A; Ribbon Cable	750-1502			296	
					■		16-Channel Digital Output; 24 VDC; 0.5 A; Low-Side Switching	750-1505			297	
					■		16-Channel Digital Output; 24 VDC; 0.5 A; Low-Side Switching; Ribbon Cable	750-1501			298	
30 VAC/DC		■					4-Channel Digital Output; 30 VAC/DC; 2.0 A; Solid-State	750-527			299	
		■					4-Channel Digital Output; 30 VAC/DC; 2.0 A; Solid-State; Isolated	750-528			300	
120/230 VAC			■				4-Channel Digital Output; 230 VAC; 0.25 A; Solid-State			753-540	301	
230 VAC/VDC	■						2-Channel Digital Output; 230 VAC; 0.3 A; Solid-State	750-509		753-509	302	
Relays	■						2-Channel Relay Output; 125 VAC; 0.5 A; Potential-Free; 2 Changeover Contacts	750-514		753-514	303	
	■						2-Channel Relay Output; 250 VAC; 0.5 A; Potential-Free; 2 Changeover Contacts	750-517*		753-517	304	
	■						2-Channel Relay Output; 250 VAC; 2.0 A; 2 Make Contacts	750-512		753-512	305	
	■						2-Channel Relay Output; 250 VAC; 2.0 A; Potential-Free; 2 Make Contacts	750-513		753-513	306	
	■						2-Channel Relay Output; 250 VAC; 2.0 A; Potential-Free; 2 Make Contacts; Without Power Jumper Contacts	750-513/000-001		753-513/000-001	307	
		■						4-Channel Relay Output; 250 VAC; 2.0 A; Potential-Free; 4 Make Contacts	750-515			308
	■						1-Channel Relay Output; 250 VAC; 16 A; Potential-Free; 1 Make Contact	750-523			309	
Functional Safety								See Section 7.8				
Ex i								See Section 7.9				
*This module is also available as a variant of the 750 XTR Series.								See Section 8				

Digital output ▶ 5 VDC ▶ high-side switching ▶ 0.02 A



750-519

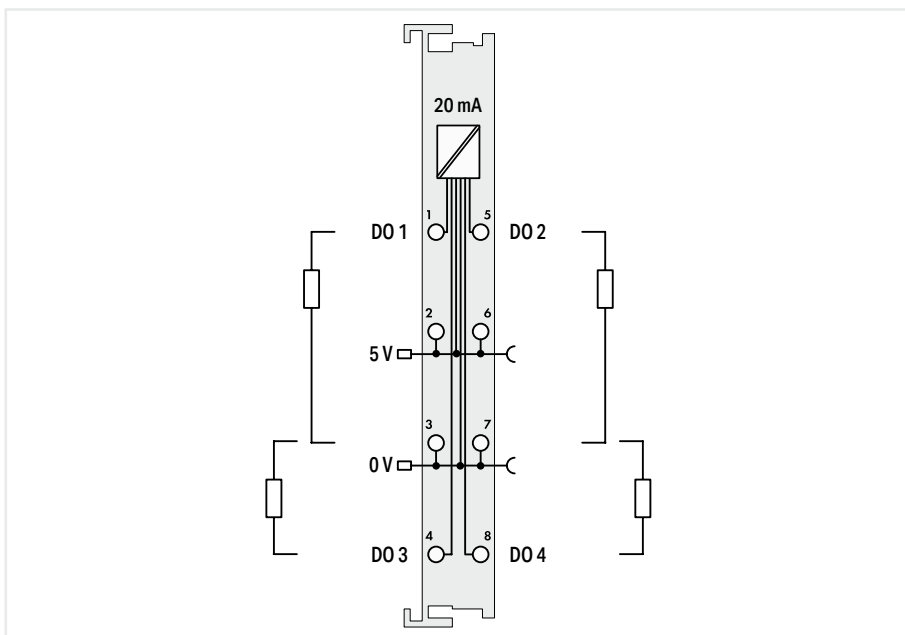

Item description	4-Channel Digital Output; 5 VDC; 20 mA
Version	Standard
Item no.	750-519
Order Text	4DO; 5 VDC; 20mA

Technical data	
Pluggable connector	fixed
Number of digital outputs	4
Signal type	Digital
Signal type (voltage)	5 VDC
Output characteristic	high-side switching
Output current per channel	0.02 A
Output current	short-circuit-protected
Load type	Resistive, inductive, lamp load
Actuator connection	2 x (2-wire); A suitable field side connection module (e.g., 750-614) must also be used to connect other actuators.
Switching frequency (max.)	5 kHz
Supply voltage (field)	5 VDC; via power jumper contacts (power supply via blade contact; transmission via spring contact)
Current consumption, field supply (module with no external load)	14 mA
Current consumption (5 V system supply)	10 mA
Output data width (internal) max.	4 bits
Isolation	500 V system/field
Ambient temperature (operation)	0 ... +55 °C
Dimensions W x H x D	(12 x 100 x 69.8) mm
Approvals	CE, OrdLoc/HazLoc

For data sheet and additional information, see:

wago.com/750-519

Notice: An additional supply module must be added for 5 VDC supply!

Digital output ▶ 5 VDC ▶ high-side switching ▶ 1 A



750-534

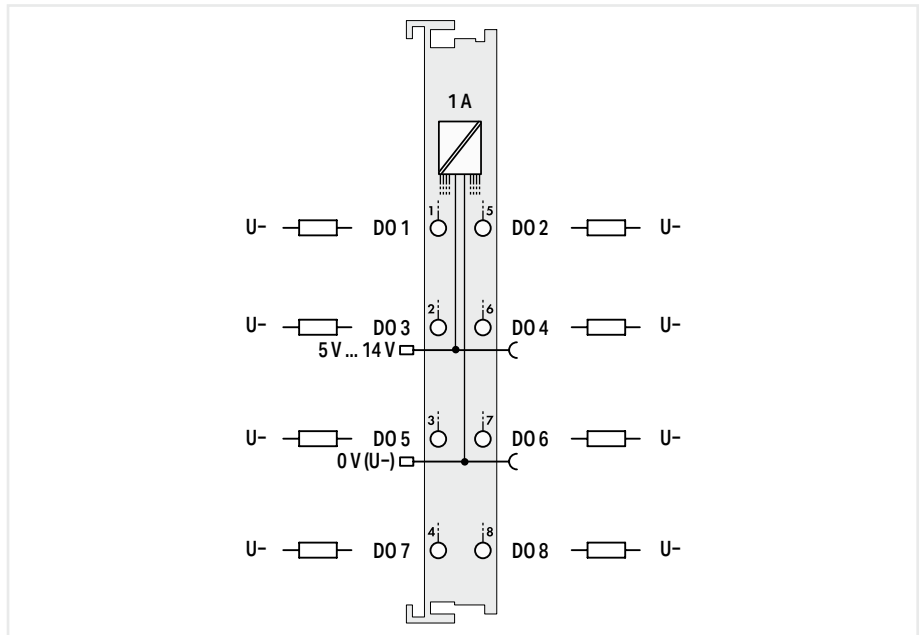

Item description	8-Channel Digital Output; 12 VDC; 1 A	
Version	Standard	pluggable (delivery without connector)
Item no.	750-534	753-534
Order Text	8DO; 12 VDC; 1A	8DO; 12 VDC; 1A
Technical data	fixed	pluggable
Pluggable connector		
Number of digital outputs		8
Signal type		Digital
Signal type (voltage)		5 VDC; 12 VDC
Output characteristic		high-side switching
Output current per channel		1 A
Output current		short-circuit-protected
Load type		Resistive, inductive
Actuator connection		8 x (1-wire)
Switching frequency (max.)		2 kHz
Supply voltage (field)		14 VDC; via power jumper contacts (power supply via blade contact; transmission via spring contact)
Current consumption, field supply (module with no external load)		25 mA
Current consumption (5 V system supply)		20 mA
Output data width (internal) max.		8 bits
Isolation		500 V system/field
Ambient temperature (operation)		0 ... +55 °C
Dimensions W x H x D	(12 x 100 x 67.8) mm	(12 x 100 x 69) mm
Approvals	Marine; OrdLoc/HazLoc; ATEX/IECEX	
For data sheet and additional information, see:	wago.com/750-534	wago.com/753-534
Accessories	Item no.	Item no.
Plug	-	753-110

Notice: An additional supply module must be added for 5–14 VDC supply!

Digital output ▶ 24 VDC ▶ high-side switching ▶ 0.5 A



750-501

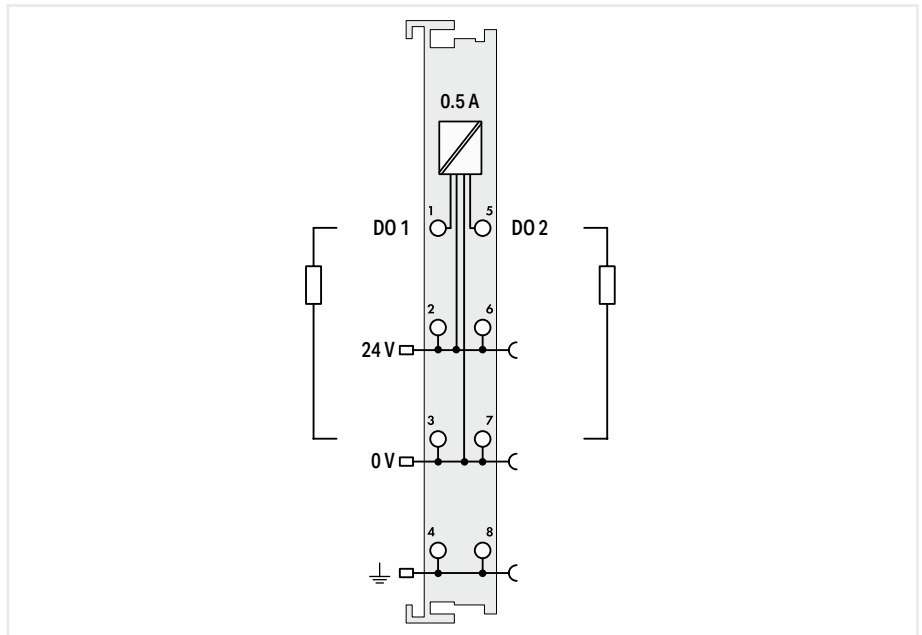

Item description	2-Channel Digital Output; 24 VDC; 0.5 A			
Version	Standard	interference-free	pluggable (delivery without connector)	pluggable (delivery without connector); Interference-free
Item no.	750-501	750-501/000-800	753-501	753-501/000-800
Order Text	2DO; 24 VDC; 0.5A	2DO; 24 VDC; 0.5A; IF	2DO; 24 VDC; 0.5A	2DO; 24 VDC; 0.5A; IF
Technical data				
Pluggable connector	fixed		pluggable	
Interference-free with safety function	-	Yes	-	Yes
Number of digital outputs	2			
Signal type	Digital			
Signal type (voltage)	24 VDC			
Output characteristic	high-side switching			
Output current per channel	0.5 A			
Output current	short-circuit-protected			
Load type	Resistive, inductive, lamp load			
Actuator connection	2 x (2-wire, 3-wire, 4-wire)			
Switching frequency (max.)	5 kHz			
Supply voltage (field)	24 VDC (-25 ... +30 %); via power jumper contacts (power supply via blade contact; transmission via spring contact)			
Current consumption, field supply (module with no external load)	15 mA			
Current consumption (5 V system supply)	3.5 mA			
Output data width (internal) max.	2 bits			
Isolation	500 V system/field			
Ambient temperature (operation)	0 ... +55 °C			
Dimensions W x H x D	(12 x 100 x 69.8) mm			
Approvals	CE; Marine; OrdLoc/HazLoc; ATEX/IECEx			
For data sheet and additional information, see:	wago.com/750-501		wago.com/753-501	
Accessories	Item no.	Item no.	Item no.	Item no.
Plug	-	-	753-110	753-110

7.3

Digital output ▶ 24 VDC ▶ high-side switching ▶ 0.5 A



750-506

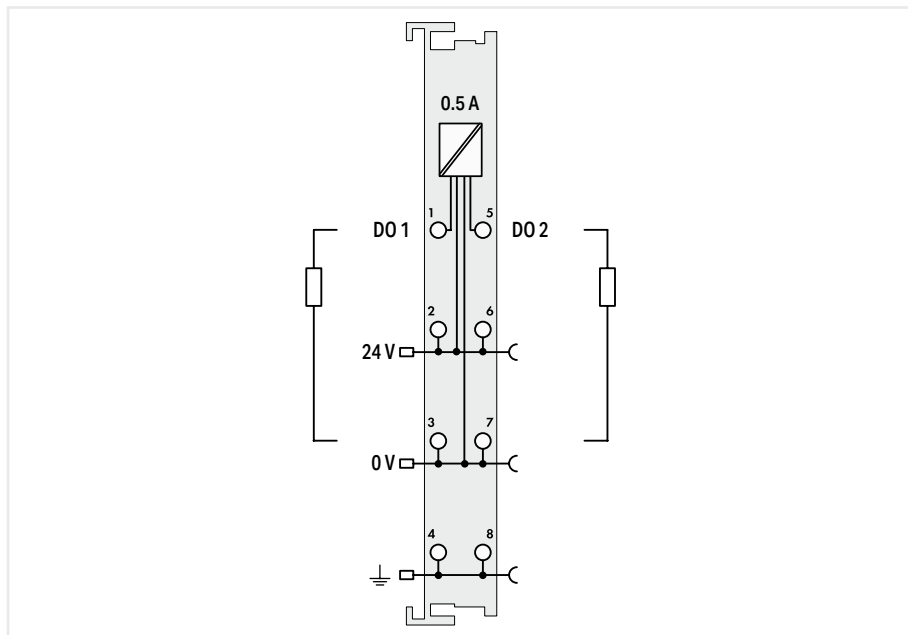

Item description	2-Channel Digital Output; 24 VDC; 0.5 A; Diagnostics		
Version	Standard	interference-free	pluggable (delivery without connector)
Item no.	750-506	750-506/000-800	753-506
Order Text	2DO; 24 VDC; 0.5A; Diagn	2DO; 24 VDC; 0.5A; IF; Diagn	2DO; 24 VDC; 0.5A; Diagn
Technical data			
Pluggable connector	fixed		pluggable
Interference-free with safety function	-	Yes	-
Number of digital outputs		2	
Signal type		Digital	
Signal type (voltage)		24 VDC	
Output characteristic		high-side switching	
Output current per channel		0.5 A	
Output current		short-circuit-protected	
Load type		Resistive, inductive, lamp load	
Actuator connection		2 x (2-wire, 3-wire, 4-wire)	
Switching frequency (max.)		5 kHz	
Diagnostics		Open circuit, short circuit, overload	
Supply voltage (field)	24 VDC (-15 ... +20 %); via power jumper contacts (power supply via blade contact; transmission via spring contact)		
Current consumption, field supply (module with no external load)		15 mA	
Current consumption (5 V system supply)		15 mA	
Input data width (internal) max.		4 bits	
Output data width (internal) max.		4 bits	
Isolation		500 V system/field	
Ambient temperature (operation)		0 ... +55 °C	
Dimensions W x H x D		(12 x 100 x 69.8) mm	
Approvals	CE, OrdLoc/HazLoc, ATEX/IECEX		
For data sheet and additional information, see:	wago.com/750-506		wago.com/753-506
Accessories	Item no.	Item no.	Item no.
Plug	-	-	753-110

7.3
Digital Output
Modules

Digital output ▶ 24 VDC ▶ high-side switching ▶ 2 A



750-502

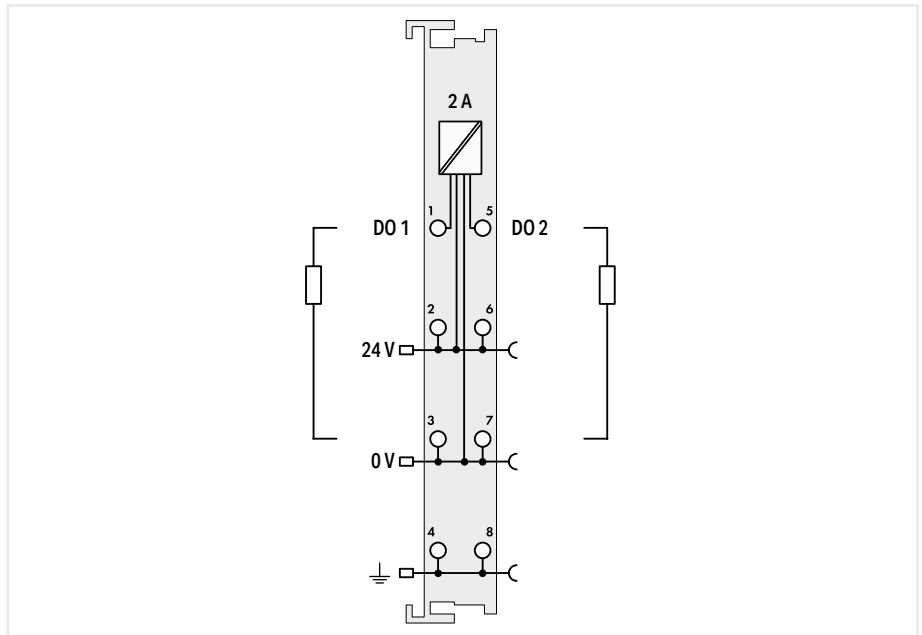

Item description	2-Channel Digital Output; 24 VDC; 2.0 A			
Version	Standard	interference-free	pluggable (delivery without connector)	pluggable (delivery without connector); Interference-free
Item no.	750-502	750-502/000-800	753-502	753-502/000-800
Order Text	2DO; 24 VDC; 2A	2DO; 24 VDC; 2A; IF	2DO; 24 VDC; 2A	2DO; 24 VDC; 2A; IF
Technical data				
Pluggable connector	fixed		pluggable	
Interference-free with safety function	-	Yes	-	Yes
Number of digital outputs	2			
Signal type	Digital			
Signal type (voltage)	24 VDC			
Output characteristic	high-side switching			
Output current per channel	2 A			
Output current	short-circuit-protected			
Load type	Resistive, inductive, lamp load			
Actuator connection	2 x (2-wire, 3-wire, 4-wire)			
Switching frequency (max.)	2.5 kHz			
Supply voltage (field)	24 VDC (-25 ... +30 %); via power jumper contacts (power supply via blade contact; transmission via spring contact)			
Current consumption, field supply (module with no external load)	15 mA			
Current consumption (5 V system supply)	3.5 mA			
Output data width (internal) max.	2 bits			
Isolation	500 V system/field			
Ambient temperature (operation)	0 ... +55 °C			
Dimensions W x H x D	(12 x 100 x 69.8) mm			
Approvals	CE; Marine; OrdLoc/HazLoc; ATEX/IECEx			
For data sheet and additional information, see:	wago.com/750-502		wago.com/753-502	
Accessories	Item no.	Item no.	Item no.	Item no.
Plug	-	-	753-110	753-110

7.3

Digital output ▶ 24 VDC ▶ high-side switching ▶ 2 A



750-508

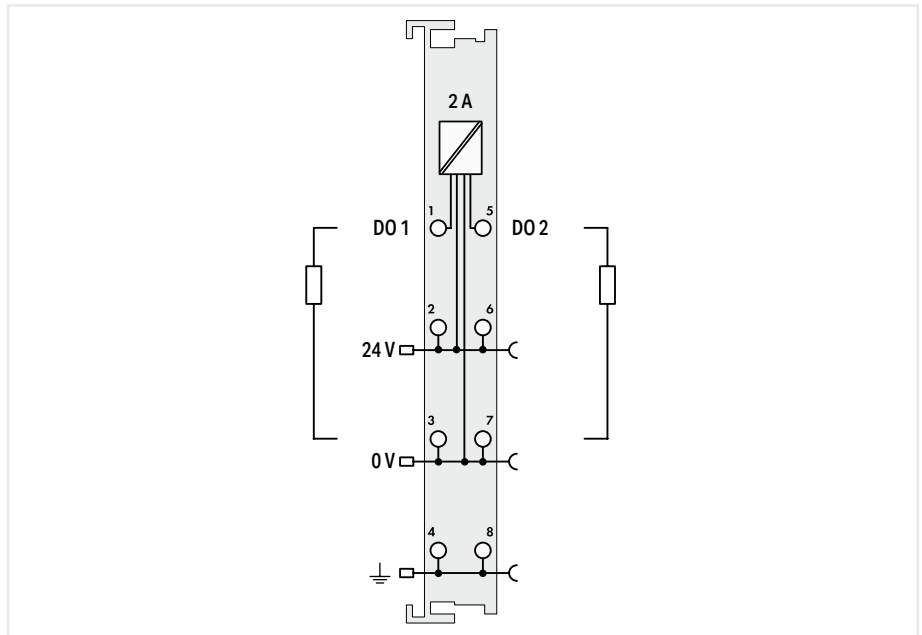

Item description	2-Channel Digital Output; 24 VDC; 2.0 A; Diagnostics		
Version	Standard	interference-free	pluggable (delivery without connector)
Item no.	750-508	750-508/000-800	753-508
Order Text	2DO; 24 VDC; 2A; Diagn	2DO; 24 VDC; 2A; IF; Diagn	2DO; 24 VDC; 2A; Diagn

Technical data			
Pluggable connector		fixed	pluggable
Interference-free with safety function	-	Yes	-
Number of digital outputs		2	
Signal type		Digital	
Signal type (voltage)		24 VDC	
Output characteristic		high-side switching	
Output current per channel		2 A	
Output current		short-circuit-protected	
Load type		Resistive, inductive, lamp load	
Actuator connection		2 x (2-wire, 3-wire, 4-wire)	
Switching frequency (max.)		1 kHz	
Diagnostics		Open circuit, short circuit, overload	
Supply voltage (field)	24 VDC (-25 ... +30 %); via power jumper contacts (power supply via blade contact; transmission via spring contact)		
Current consumption, field supply (module with no external load)		7 mA	
Current consumption (5 V system supply)		14 mA	
Input data width (internal) max.		2 bits	
Output data width (internal) max.		2 bits	
Isolation		500 V system/field	
Ambient temperature (operation)		0 ... +55 °C	
Dimensions W x H x D		(12 x 100 x 69.8) mm	
Approvals	CE; L; Marine; OrdLoc/HazLoc; ATEX/IECEx		
For data sheet and additional information, see:	wago.com/750-508		wago.com/753-508
Accessories	Item no.	Item no.	Item no.
Plug	-	-	753-110

Digital output ▶ 24 VDC ▶ high-side switching ▶ 0.5 A



750-504

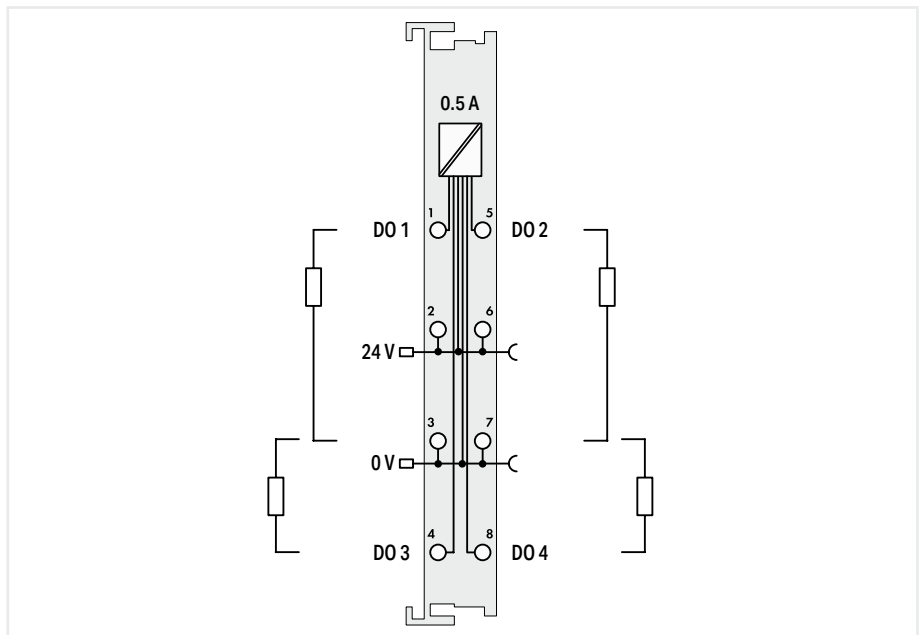

Item description					
Version					
Item no.					
Order Text					
4-Channel Digital Output; 24 VDC; 0.5 A					
Standard	ext. temperature	interference-free	pluggable (delivery without connector)	interference-free; extended temperature	
750-504	750-504/025-000	750-504/000-800	753-504	750-504/025-800	
4DO; 24 VDC; 0.5A	4DO; 24 VDC; 0.5A; T	4DO; 24 VDC; 0.5A; IF	4DO; 24 VDC; 0.5A	4DO; 24 VDC; 0.5A; IF; T	

Technical data					
Pluggable connector	fixed		pluggable		fixed
Interference-free with safety function	-		Yes		Yes
Number of digital outputs	4				
Signal type	Digital				
Signal type (voltage)	24 VDC				
Output characteristic	high-side switching				
Output current per channel	0.5 A				
Output current	short-circuit-protected				
Load type	Resistive, inductive, lamp load				
Actuator connection	2 x (2-wire, 3-wire); A suitable field side connection module (e.g., 750-614) must also be used to connect other actuators.				
Switching frequency (max.)	1 kHz				
Supply voltage (field)	24 VDC (-25 ... +30 %); via power jumper contacts (power supply via blade contact; transmission via spring contact)				
Current consumption, field supply (module with no external load)	30 mA				
Current consumption (5 V system supply)	10 mA				
Output data width (internal) max.	4 bits				
Isolation	500 V system/field				
Ambient temperature (operation)	0 ... +55 °C	-20 ... +60 °C	0 ... +55 °C		-20 ... +60 °C
Dimensions W x H x D	(12 x 100 x 69.8) mm				
Approvals	CE; Marine; OrdLoc/HazLoc; ATEX/IECEX				
For data sheet and additional information, see:	wago.com/750-504		wago.com/753-504	wago.com/750-504/025-800	
Accessories	Item no.	Item no.	Item no.	Item no.	Item no.
Plug	-	-	753-110	-	

7.3

Digital output ▶ 24 VDC ▶ high-side switching ▶ 0.5 A



750-531

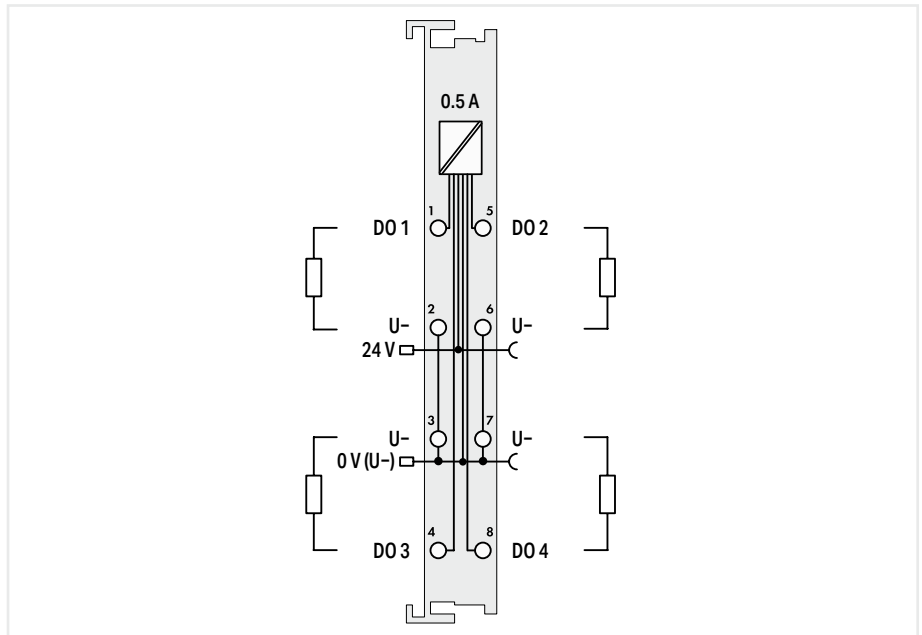

Item description	4-Channel Digital Output; 24 VDC; 0.5 A; 2-wire connection			
Version	Standard	interference-free	pluggable (delivery without connector)	pluggable (delivery without connector); Interference-free
Item no.	750-531	750-531/000-800	753-531	753-531/000-800
Order Text	4DO; 24 VDC; 0.5A; 2-wire	4DO; 24 VDC; 0.5A; IF; 2-wire	4DO; 24 VDC; 0.5A; 2-wire	4DO; 24 VDC; 0.5A; IF; 2-wire

Technical data				
Pluggable connector	fixed		pluggable	
Interference-free with safety function	-	Yes	-	Yes
Number of digital outputs	4			
Signal type	Digital			
Signal type (voltage)	24 VDC			
Output characteristic	high-side switching			
Output current per channel	0.5 A			
Output current	short-circuit-protected			
Load type	Resistive, inductive, lamp load			
Actuator connection	4 x (2-wire)			
Switching frequency (max.)	1 kHz			
Short-circuit current	1.7 A			
Supply voltage (field)	24 VDC (-25 ... +30 %); via power jumper contacts (power supply via blade contact; transmission via spring contact)			
Current consumption, field supply (module with no external load)	30 mA			
Current consumption (5 V system supply)	10 mA			
Output data width (internal) max.	4 bits			
Isolation	500 V system/field			
Ambient temperature (operation)	0 ... +55 °C			
Dimensions W x H x D	(12 x 100 x 69.8) mm			
Approvals	CE; Marine; OrdLoc/HazLoc; ATEX/IECEx			
For data sheet and additional information, see:	wago.com/750-531		wago.com/753-531	
Accessories	Item no.	Item no.	Item no.	Item no.
Plug	-	-	753-110	753-110

Digital output ► 24 VDC ► high-side switching ► 0.5 A



750-532

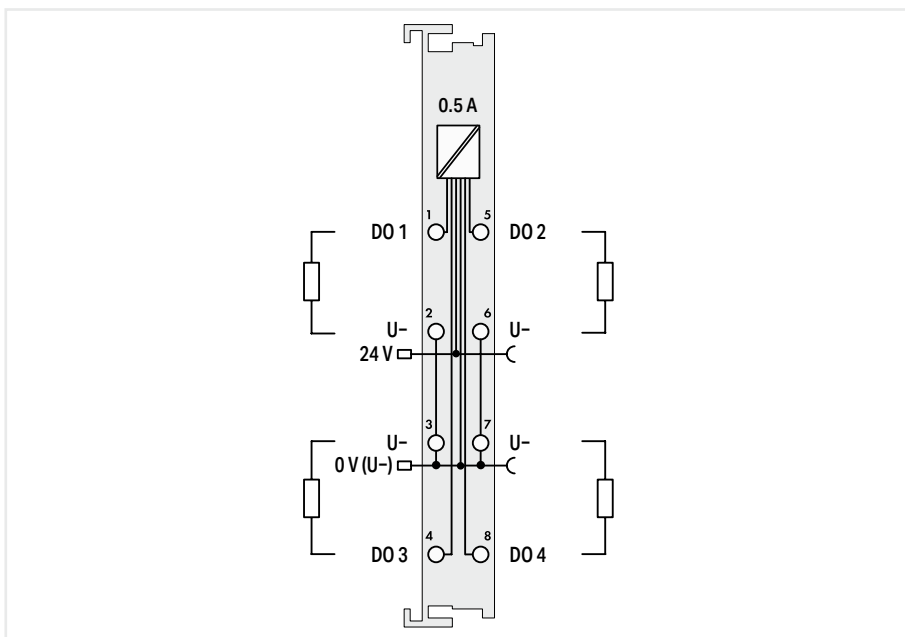

Item description	4-Channel Digital Output; 24 VDC; 0.5 A; Diagnostics
Version	Standard
Item no.	750-532
Order Text	4DO; 24 VDC; 0.5A; Diagn

Technical data	
Pluggable connector	fixed
Number of digital outputs	4
Signal type	Digital
Signal type (voltage)	24 VDC
Output characteristic	high-side switching
Output current per channel	0.5 A
Output current	short-circuit-protected
Load type	Resistive, inductive, lamp load
Actuator connection	4 x (2-wire)
Switching frequency (max.)	2 kHz
Diagnostics	Open circuit, short circuit, overload
Supply voltage (field)	24 VDC (-25 ... +30 %); via power jumper contacts (power supply via blade contact; transmission via spring contact)
Current consumption, field supply (module with no external load)	13 mA
Current consumption (5 V system supply)	10 mA
Input data width (internal) max.	4 bits
Output data width (internal) max.	4 bits
Isolation	500 V system/field
Ambient temperature (operation)	0 ... +55 °C
Dimensions W x H x D	(12 x 100 x 67.8) mm
Approvals	CE; Marine; OrdLoc/HazLoc; ATEX/IECEx

For data sheet and additional information, see:

wago.com/750-532

Digital output ▶ 24 VDC ▶ low-side switching ▶ 0.5 A



750-516

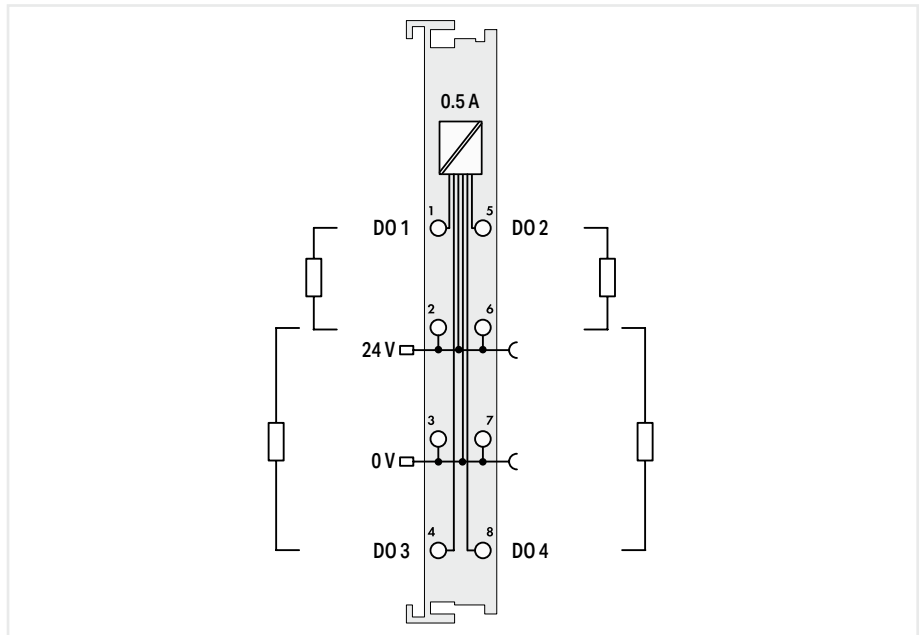

Item description	4-Channel Digital Output; 24 VDC; 0.5 A; Low-side switching	
Version	Standard	pluggable (delivery without connector)
Item no.	750-516	753-516
Order Text	4DO; 24 VDC; 0.5A; LSS	4DO; 24 VDC; 0.5A; LSS
Technical data	fixed	pluggable
Pluggable connector		
Number of digital outputs		4
Signal type		Digital
Signal type (voltage)		24 VDC
Output characteristic		low-side switching
Output current per channel		0.5 A
Output current		short-circuit-protected
Load type		Resistive, inductive, lamp load
Actuator connection	2 x (2-wire); A suitable field side connection module (e.g., 750-614) must also be used to connect other actuators.	
Switching frequency (max.)	5 kHz	
Supply voltage (field)	24 VDC (-25 ... +30 %); via power jumper contacts (power supply via blade contact; transmission via spring contact)	
Current consumption, field supply (module with no external load)	30 mA	
Current consumption (5 V system supply)	7 mA	
Output data width (internal) max.	4 bits	
Isolation	500 V system/field	
Ambient temperature (operation)	0 ... +55 °C	
Dimensions W x H x D	(12 x 100 x 69.8) mm	
Approvals	CE; L; Marine; OrdLoc/HazLoc; ATEX/IECEX	
For data sheet and additional information, see:	wago.com/750-516	wago.com/753-516
Accessories	Item no.	Item no.
Plug	-	753-110

Digital output ► 24 VDC ► high-side switching ► 0.5 A



750-530

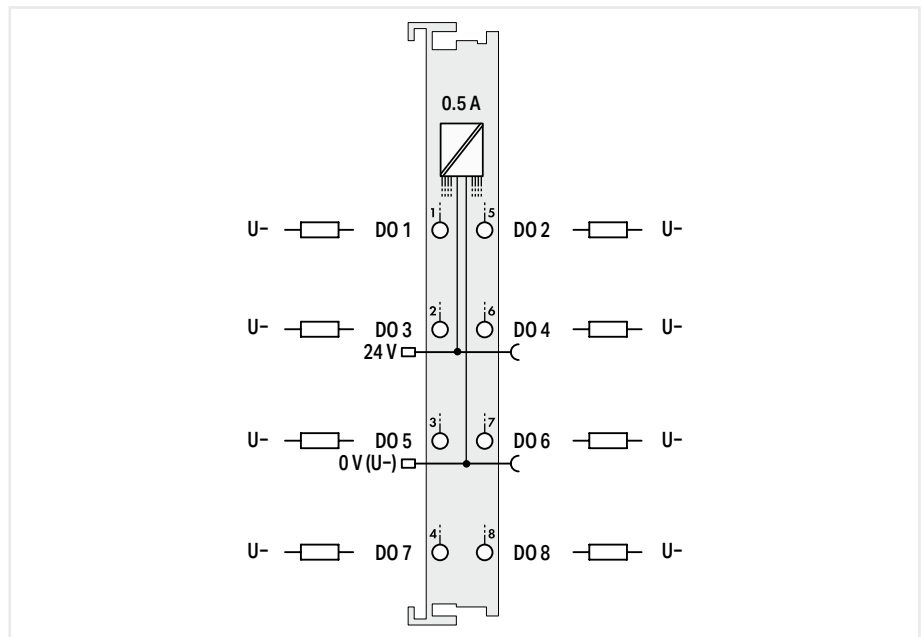

Item description	8-Channel Digital Output; 24 VDC; 0.5 A		
Version	Standard	ext. temperature	pluggable (delivery without connector)
Item no.	750-530	750-530/025-000	753-530
Order Text	8DO; 24 VDC; 0.5A	8DO; 24 VDC; 0.5A; T	8DO; 24 VDC; 0.5A
Technical data			
Pluggable connector	fixed		pluggable
Number of digital outputs	8		
Signal type	Digital		
Signal type (voltage)	24 VDC		
Output characteristic	high-side switching		
Output current per channel	0.5 A		
Output current	short-circuit-protected		
Load type	Resistive, inductive, lamp load		
Actuator connection	8 x (1-wire)		
Switching frequency (max.)	2 kHz		
Supply voltage (field)	24 VDC (-25 ... +30 %); via power jumper contacts (power supply via blade contact; transmission via spring contact)		
Current consumption, field supply (module with no external load)	15 mA		
Current consumption (5 V system supply)	25 mA		
Output data width (internal) max.	8 bits		
Isolation	500 V system/field		
Ambient temperature (operation)	0 ... +55 °C	-20 ... +60 °C	0 ... +55 °C
Dimensions W x H x D	(12 x 100 x 67.8) mm		(12 x 100 x 69) mm
Approvals	CE; Marine; OrdLoc/HazLoc; ATEX/IECEX		
For data sheet and additional information, see:	wago.com/750-530		wago.com/753-530
Accessories	Item no.	Item no.	Item no.
Plug	-	-	753-110

Digital output ▶ 24 VDC ▶ high-side switching ▶ 0.5 A



750-537

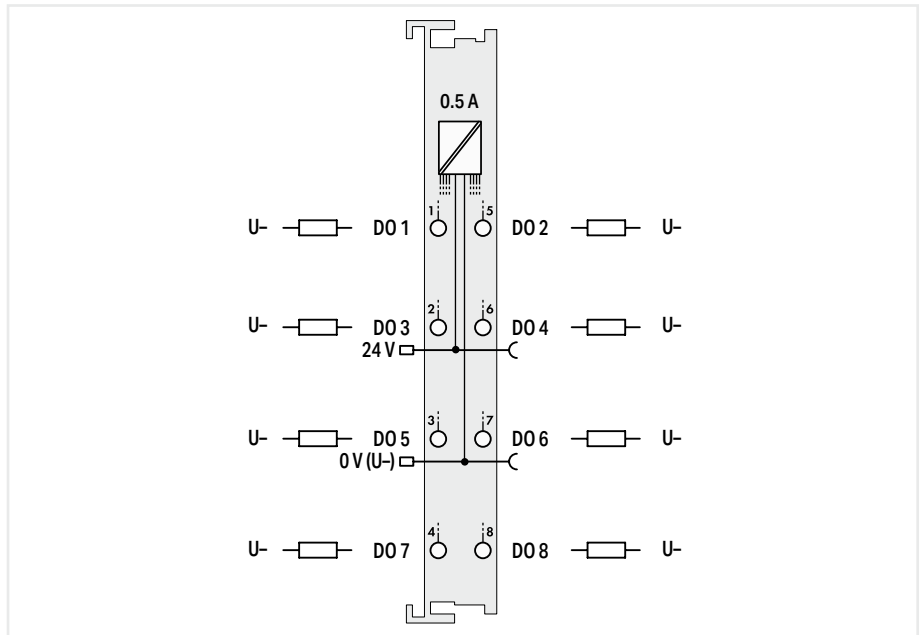

Item description	8-Channel Digital Output; 24 VDC; 0.5 A; Diagnostics	
Version	Standard	pluggable (delivery without connector)
Item no.	750-537	753-537
Order Text	8DO; 24 VDC; 0.5A; Diagn	8DO; 24 VDC; 0.5A; Diagn
Technical data	fixed	pluggable
Pluggable connector		
Number of digital outputs		8
Signal type		Digital
Signal type (voltage)		24 VDC
Output characteristic		high-side switching
Output current per channel		0.5 A
Output current		short-circuit-protected
Load type		Resistive, inductive, lamp load
Actuator connection		8 x (1-wire)
Switching frequency (max.)		1 kHz
Diagnostics		Open circuit, short circuit, overload
Supply voltage (field)	24 VDC (-25 ... +30 %); via power jumper contacts (power supply via blade contact; transmission via spring contact)	
Current consumption, field supply (module with no external load)	16 mA	
Current consumption (5 V system supply)	50 mA	
Input data width (internal) max.	8 bits	
Output data width (internal) max.	8 bits	
Isolation	500 V system/field	
Ambient temperature (operation)	0 ... +55 °C	
Dimensions W x H x D	(12 x 100 x 67.8) mm	(12 x 100 x 69) mm
Approvals	CE; Marine; OrdLoc/HazLoc; ATEX/IECEX	
For data sheet and additional information, see:	wago.com/750-537	wago.com/753-537
Accessories	Item no.	Item no.
Plug	-	753-110

Digital output ► 24 VDC ► high-side switching ► 0.5 A



750-1515

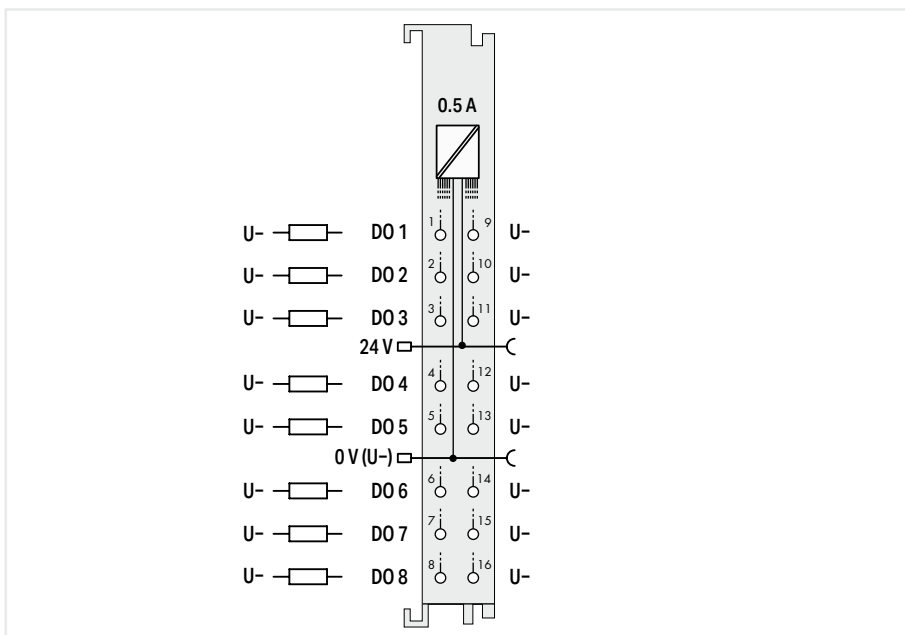

Item description	8-Channel Digital Output; 24 VDC; 0.5 A; 2-wire connection
Version	Standard with 16 connectors
Item no.	750-1515
Order Text	8DO; 24 VDC; 0.5A; 2-wire

Technical data	
Pluggable connector	fixed
Number of digital outputs	8
Signal type	Digital
Signal type (voltage)	24 VDC
Output characteristic	high-side switching
Output current per channel	0.5 A
Output current	short-circuit-protected
Load type	Resistive, inductive, lamp load
Actuator connection	8 x (2-wire)
Switching frequency (max.)	1 kHz
Supply voltage (field)	24 VDC (-25 ... +30 %); via power jumper contacts (power supply via blade contact; transmission via spring contact)
Current consumption, field supply (module with no external load)	15 mA
Current consumption (5 V system supply)	20 mA
Output data width (internal) max.	8 bits
Isolation	500 V system/field
Ambient temperature (operation)	0 ... +55 °C
Dimensions W x H x D	(12 x 100 x 69) mm
Approvals	CE; Marine; OrdLoc/HazLoc; ATEX/IECEx

For data sheet and additional information, see:

wago.com/750-1515

Digital output ▶ 24 VDC ▶ low-side switching ▶ 0.5 A



750-536

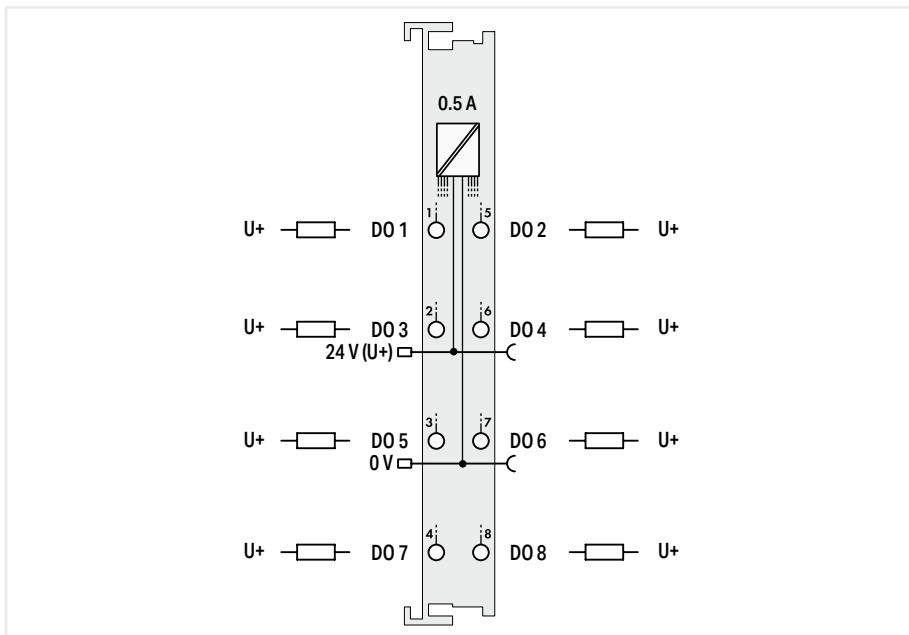

Item description	8-Channel Digital Output; 24 VDC; 0.5 A; Low-side switching	
Version	Standard	pluggable (delivery without connector)
Item no.	750-536	753-536
Order Text	8DO; 24 VDC; 0.5A; LSS	8DO; 24 VDC; 0.5A; LSS
Technical data	fixed	pluggable
Pluggable connector		
Number of digital outputs		8
Signal type		Digital
Signal type (voltage)		24 VDC
Output characteristic		low-side switching
Output current per channel		0.5 A
Output current		short-circuit-protected
Load type		Resistive, inductive, lamp load
Actuator connection		8 x (1-wire)
Switching frequency (max.)		2 kHz
Supply voltage (field)		24 VDC (-25 ... +30 %); via power jumper contacts (power supply via blade contact; transmission via spring contact)
Current consumption, field supply (module with no external load)		12 mA
Current consumption (5 V system supply)		25 mA
Output data width (internal) max.		8 bits
Isolation		500 V system/field
Ambient temperature (operation)		0 ... +55 °C
Dimensions W x H x D	(12 x 100 x 67.8) mm	(12 x 100 x 69) mm
Approvals		
For data sheet and additional information, see:	wago.com/750-536	wago.com/753-536
Accessories	Item no.	Item no.
Plug	-	753-110

Digital output ► 24 VDC ► low-side switching ► 0.5 A



750-1516

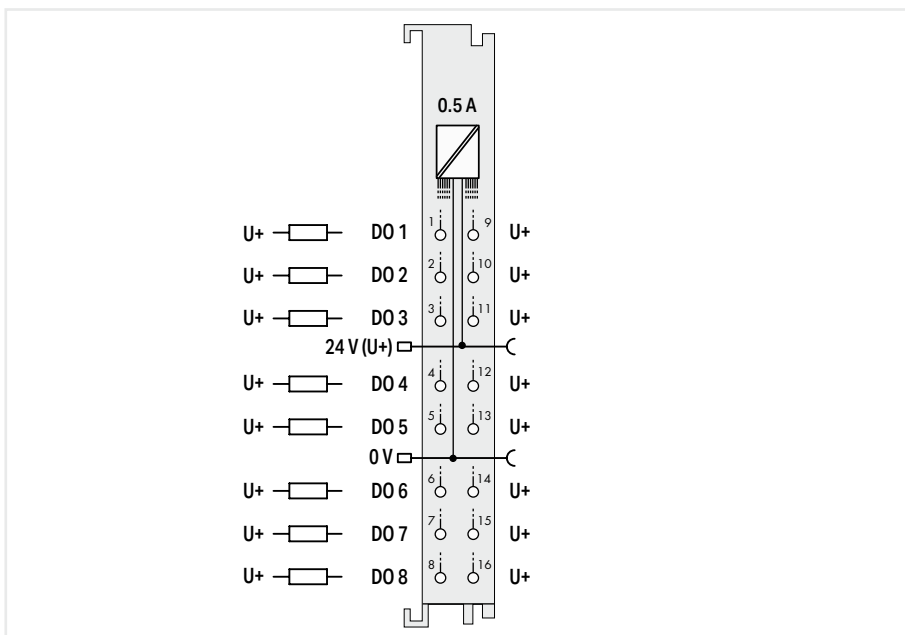

Item description	8-Channel Digital Output; 24 VDC; 0.5 A; Low-side switching; 2-wire connection
Version	Standard with 16 connectors
Item no.	750-1516
Order Text	8DO; 24 VDC; 0.5A; LSS; 2-wire

Technical data	
Pluggable connector	fixed
Number of digital outputs	8
Signal type	Digital
Signal type (voltage)	24 VDC
Output characteristic	low-side switching
Output current per channel	0.5 A
Output current	short-circuit-protected
Load type	Resistive, inductive, lamp load
Actuator connection	8 x (2-wire)
Switching frequency (max.)	1 kHz
Supply voltage (field)	24 VDC (-25 ... +30 %); via power jumper contacts (power supply via blade contact; transmission via spring contact)
Current consumption, field supply (module with no external load)	8 mA
Current consumption (5 V system supply)	20 mA
Output data width (internal) max.	8 bits
Isolation	500 V system/field
Ambient temperature (operation)	0 ... +55 °C
Dimensions W x H x D	(12 x 100 x 69) mm
Approvals	CE; Marine; OrdLoc/HazLoc; ATEX/IECEX

For data sheet and additional information, see:

wago.com/750-1516

Digital output ▶ 24 VDC ▶ high-side switching ▶ 0.5 A



750-1500

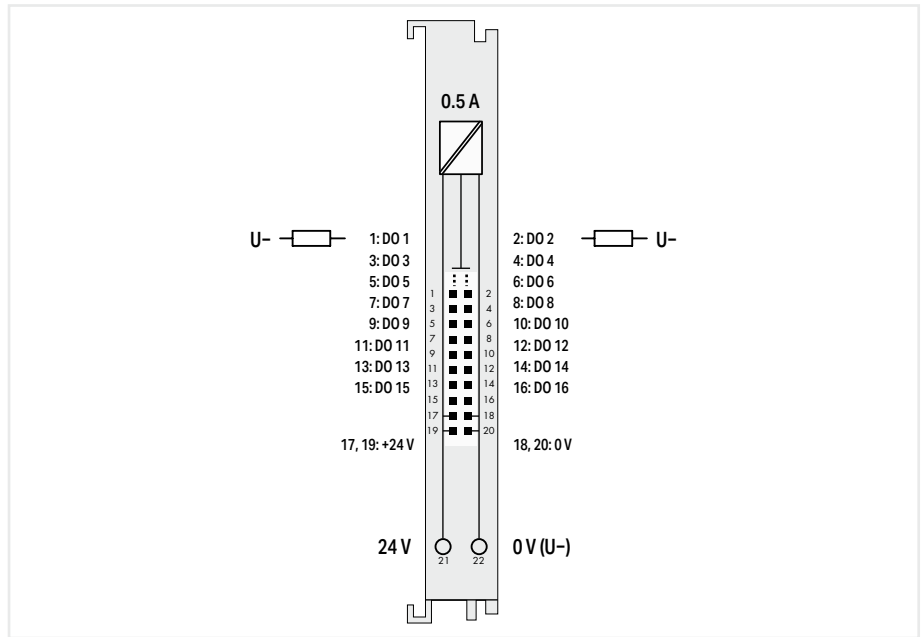

Item description	16-Channel Digital Output; 24 VDC; 0.5 A; Ribbon cable
Version	Standard with ribbon cable connector
Item no.	750-1500
Order Text	16DO; 24 VDC; 0.5A; Ribbon Cable

Technical data	
Pluggable connector	fixed
Number of digital outputs	16
Signal type	Digital
Signal type (voltage)	24 VDC
Output characteristic	high-side switching
Output current per channel	0.5 A
Output current	short-circuit-protected
Load type	Resistive, inductive, lamp load
Actuator connection	16 x (1-wire)
Switching frequency (max.)	1 kHz
Supply voltage (field)	24 VDC (-25 ... +30 %); via pluggable connector (CAGE CLAMP® connection)
Current consumption, field supply (module with no external load)	29 mA
Current consumption (5 V system supply)	40 mA
Output data width (internal) max.	16 bits
Isolation	500 V system/field
Ambient temperature (operation)	0 ... +55 °C
Dimensions W x H x D	(12 x 100 x 74.1) mm
Approvals	CE; L; Marine; OrdLoc/HazLoc; ATEX/IECEx

For data sheet and additional information, see:

wago.com/750-1500

Digital output ► 24 VDC ► high-side switching ► 0.5 A



750-1504

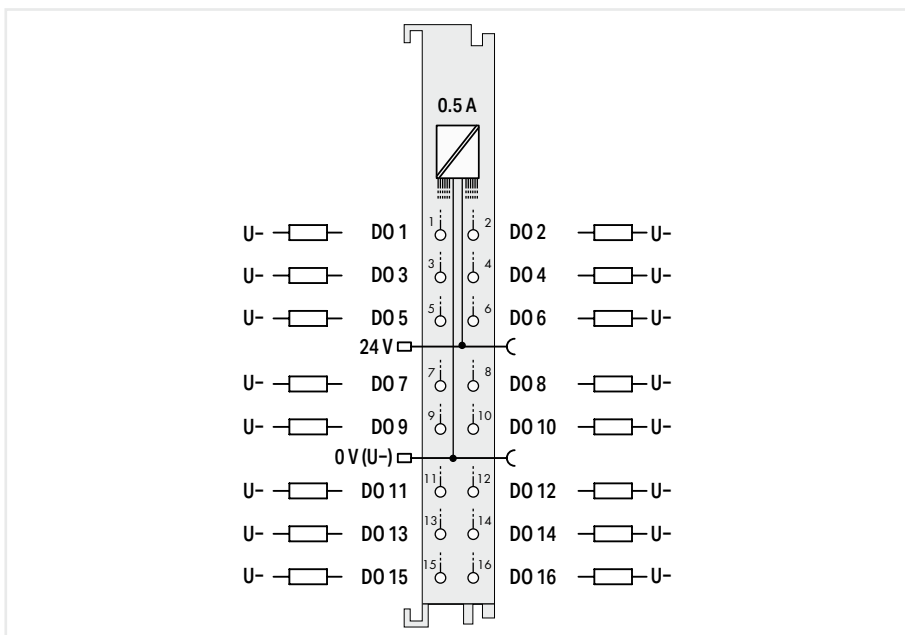

Item description	16-Channel Digital Output; 24 VDC; 0.5 A
Version	Standard with 16 connectors
Item no.	750-1504
Order Text	16DO; 24 VDC; 0.5A
Technical data	
Pluggable connector	fixed
Number of digital outputs	16
Signal type	Digital
Signal type (voltage)	24 VDC
Output characteristic	high-side switching
Output current per channel	0.5 A
Output current	short-circuit-protected
Load type	Resistive, inductive, lamp load
Actuator connection	16 x (1-wire)
Switching frequency (max.)	1 kHz
Supply voltage (field)	24 VDC (-25 ... +30 %); via power jumper contacts (power supply via blade contact; transmission via spring contact)
Current consumption, field supply (module with no external load)	29 mA
Current consumption (5 V system supply)	40 mA
Output data width (internal) max.	16 bits
Isolation	500 V system/field
Ambient temperature (operation)	0 ... +55 °C
Dimensions W x H x D	(12 x 100 x 69) mm
Approvals	CE; Marine; OrdLoc/HazLoc; ATEX/IECEX

For data sheet and additional information, see:

wago.com/750-1504

Digital input; Digital output ▶ 24 VDC ▶ high-side switching ▶ 0.5 A



750-1502

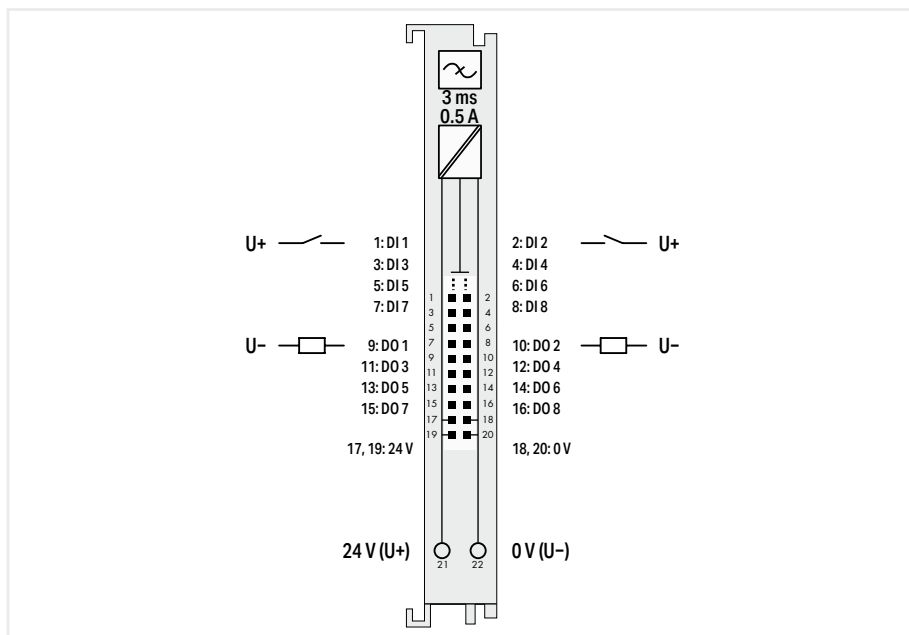

Item description	8-Channel Digital Input/Output; 24 VDC; 0.5 A; Ribbon cable
Version	Standard with ribbon cable connector
Item no.	750-1502
Order Text	8DIO; 24 VDC; 0.5A; Ribbon Cable

Technical data	
Pluggable connector	fixed
Number of digital inputs	8
Voltage range for signal (0)	-3 ... +5 VDC
Voltage range for signal (1)	15 ... 30 VDC
Sensor connection	8 x (1-wire)
Input characteristic	high-side switching
Input filter (digital)	3 ms
Input current per channel for signal (1) typ.	2.4 mA
Number of digital outputs	8
Signal type	Digital
Signal type (voltage)	24 VDC
Output characteristic	high-side switching
Output current per channel	0.5 A
Output current	short-circuit-protected
Load type	Resistive, inductive, lamp load
Actuator connection	8 x (1-wire)
Switching frequency (max.)	1 kHz
Supply voltage (field)	24 VDC (-25 ... +30 %); via pluggable connector (CAGE CLAMP® connection)
Current consumption, field supply (module with no external load)	16 mA
Current consumption (5 V system supply)	30 mA
Input data width (internal) max.	8 bits
Output data width (internal) max.	8 bits
Isolation	500 V system/field
Ambient temperature (operation)	0 ... +55 °C
Dimensions W x H x D	(12 x 100 x 74.1) mm
Approvals	CE; Marine; OrdLoc/HazLoc; ATEX/IECEx

For data sheet and additional information, see:

wago.com/750-1502

Digital input; Digital output ▶ 24 VDC ▶ high-side switching ▶ 0.5 A



750-1506

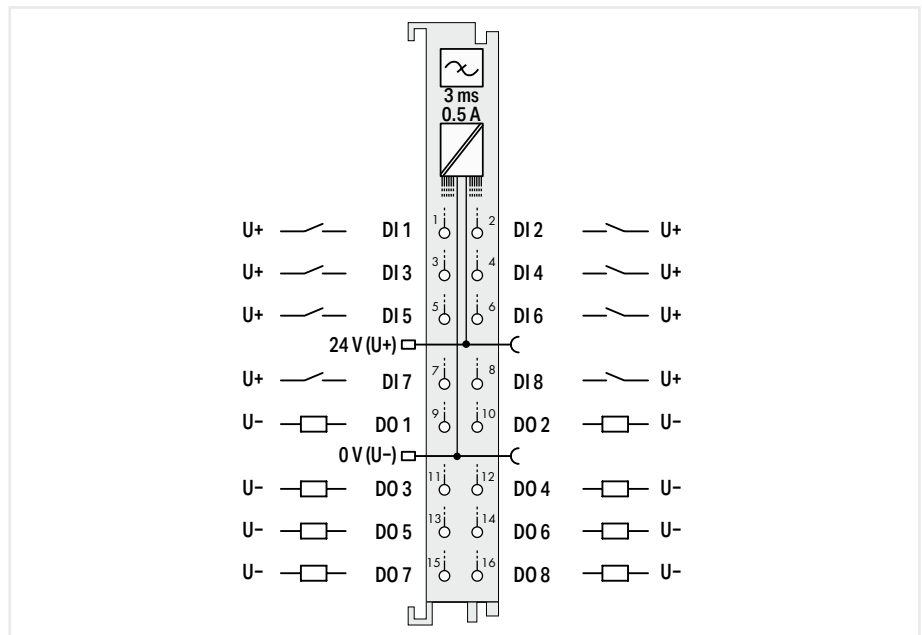

Item description	8-Channel Digital Input/Output; 24 VDC; 0.5 A
Version	Standard with 16 connectors
Item no.	750-1506
Order Text	8DIO; 24 VDC; 0.5A

Technical data	
Pluggable connector	fixed
Number of digital inputs	8
Voltage range for signal (0)	-3 ... +5 VDC
Voltage range for signal (1)	15 ... 30 VDC
Sensor connection	8 x (1-wire)
Input characteristic	high-side switching
Input filter (digital)	3 ms
Input current per channel for signal (1) typ.	2.4 mA
Number of digital outputs	8
Signal type	Digital
Signal type (voltage)	24 VDC
Output characteristic	high-side switching
Output current per channel	0.5 A
Output current	short-circuit-protected
Load type	Resistive, inductive, lamp load
Actuator connection	8 x (1-wire)
Switching frequency (max.)	1 kHz
Supply voltage (field)	24 VDC (-25 ... +30 %); via power jumper contacts (power supply via blade contact; transmission via spring contact)
Current consumption, field supply (module with no external load)	16 mA
Current consumption (5 V system supply)	30 mA
Input data width (internal) max.	8 bits
Output data width (internal) max.	8 bits
Isolation	500 V system/field
Ambient temperature (operation)	0 ... +55 °C
Dimensions W x H x D	(12 x 100 x 69) mm
Approvals	CE; Marine; OrdLoc/HazLoc; ATEX/IECEX

For data sheet and additional information, see:

wago.com/750-1506

Digital output ▶ 24 VDC ▶ low-side switching ▶ 0.5 A



750-1501

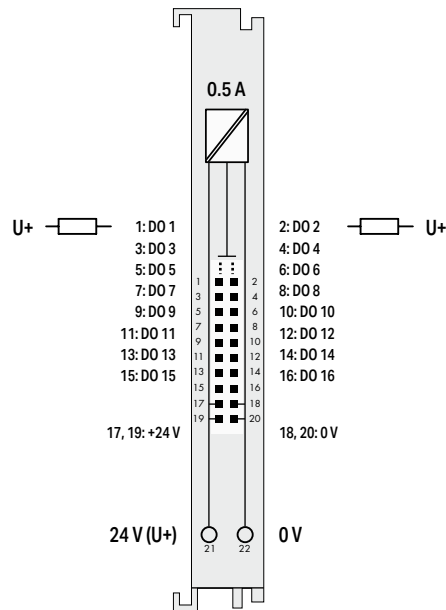

Item description	16-Channel Digital Output; 24 VDC; 0.5 A; Low-side switching; Ribbon cable
Version	Standard with ribbon cable connector
Item no.	750-1501
Order Text	16DO; 24 VDC; 0.5A; LSS; Ribbon Cable
Technical data	
Pluggable connector	fixed
Number of digital outputs	16
Signal type	Digital
Signal type (voltage)	24 VDC
Output characteristic	low-side switching
Output current per channel	0.5 A
Output current	short-circuit-protected
Load type	Resistive, inductive, lamp load
Actuator connection	16 x (1-wire)
Switching frequency (max.)	1 kHz
Supply voltage (field)	24 VDC (-25 ... +30 %); via pluggable connector (CAGE CLAMP® connection)
Current consumption, field supply (module with no external load)	11 mA
Current consumption (5 V system supply)	40 mA
Output data width (internal) max.	16 bits
Isolation	500 V system/field
Ambient temperature (operation)	0 ... +55 °C
Dimensions W x H x D	(12 x 100 x 74.1) mm
Approvals	CE; L; Marine; OrdLoc/HazLoc; ATEX/IECEx
For data sheet and additional information, see:	wago.com/750-1501

Digital output ► 24 VDC ► low-side switching ► 0.5 A



750-1505

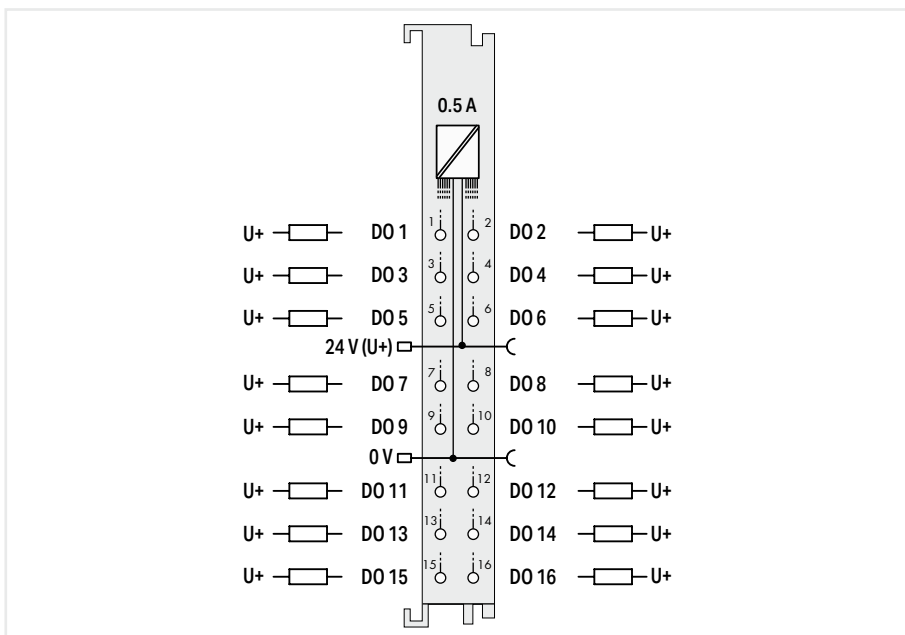

Item description	16-Channel Digital Output; 24 VDC; 0.5 A; Low-side switching
Version	Standard with 16 connectors
Item no.	750-1505
Order Text	16DO; 24 VDC; 0.5A; LSS

Technical data	
Pluggable connector	fixed
Number of digital outputs	16
Signal type	Digital
Signal type (voltage)	24 VDC
Output characteristic	low-side switching
Output current per channel	0.5 A
Output current	short-circuit-protected
Load type	Resistive, inductive, lamp load
Actuator connection	16 x (1-wire)
Switching frequency (max.)	1 kHz
Supply voltage (field)	24 VDC (-25 ... +30 %); via power jumper contacts (power supply via blade contact; transmission via spring contact)
Current consumption, field supply (module with no external load)	11 mA
Current consumption (5 V system supply)	40 mA
Output data width (internal) max.	16 bits
Isolation	500 V system/field
Ambient temperature (operation)	0 ... +55 °C
Dimensions W x H x D	(12 x 100 x 69) mm
Approvals	CE; Marine; OrdLoc/HazLoc; ATEX/IECEX

For data sheet and additional information, see:

wago.com/750-1505

Digital output ► 30 VAC/DC ► high-side switching ► 2 A



750-527

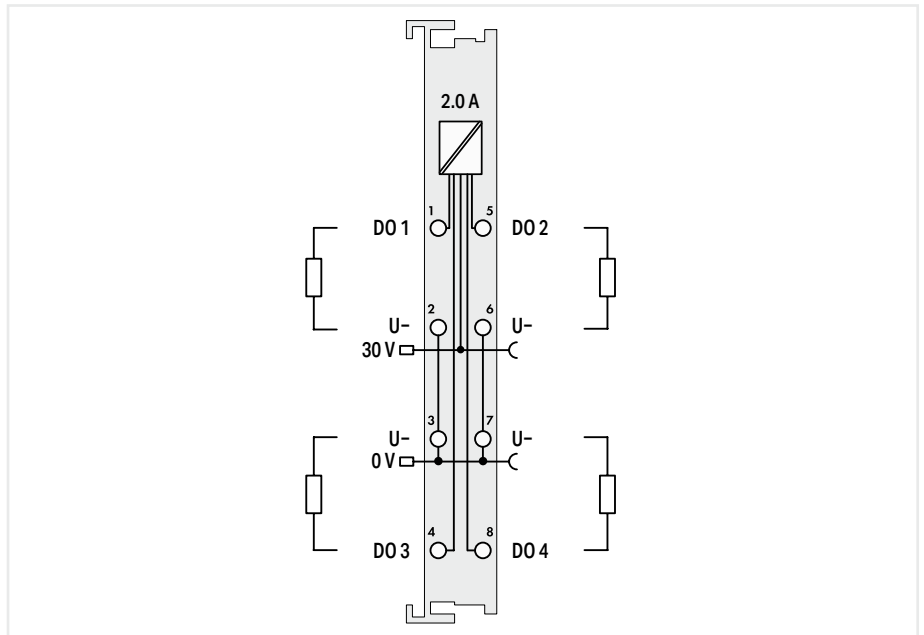

Item description	4-Channel Digital Output; 30 VAC/VDC; 2.0 A; Solid-state
Version	Standard
Item no.	750-527
Order Text	4DO; 30V AC/DC; 2.0A; SSR
Technical data	
Pluggable connector	fixed
Number of digital outputs	4
Signal type	Digital
Signal type (voltage)	30 VAC/DC
Output characteristic	high-side switching
Output current per channel	2 A
Output current (module)	8 A
Output current	requires external fuses
Delay time T _{off} from 1 to 0	20000 µs
Delay time T _{on} from 0 to 1	1000 µs
Load type	Resistive; inductive (Limit induction voltage peaks externally)
Actuator connection	4 x (2-wire)
Switching frequency (max.)	1 Hz
Supply voltage (field)	30 VSELV AC/DC; via power jumper contacts (power supply via blade contact; transmission via spring contact)
Current consumption, field supply (module with no external load)	0 mA
Current consumption (5 V system supply)	57 mA
Output data width (internal) max.	4 bits
Isolation	500 V system/field
Overvoltage category	II
Ambient temperature (operation)	0 ... +55 °C
Dimensions W x H x D	(12 x 100 x 69.8) mm
Approvals	CE; OrdLoc/HazLoc
For data sheet and additional information, see:	wago.com/750-527

Notice: A suitable supply module (e.g., 750-612) must be provided for AC operation or when using DC voltages >31.2 V!

Digital output ► 30 VAC/DC; isolated ► high-side switching ► 2 A



750-528

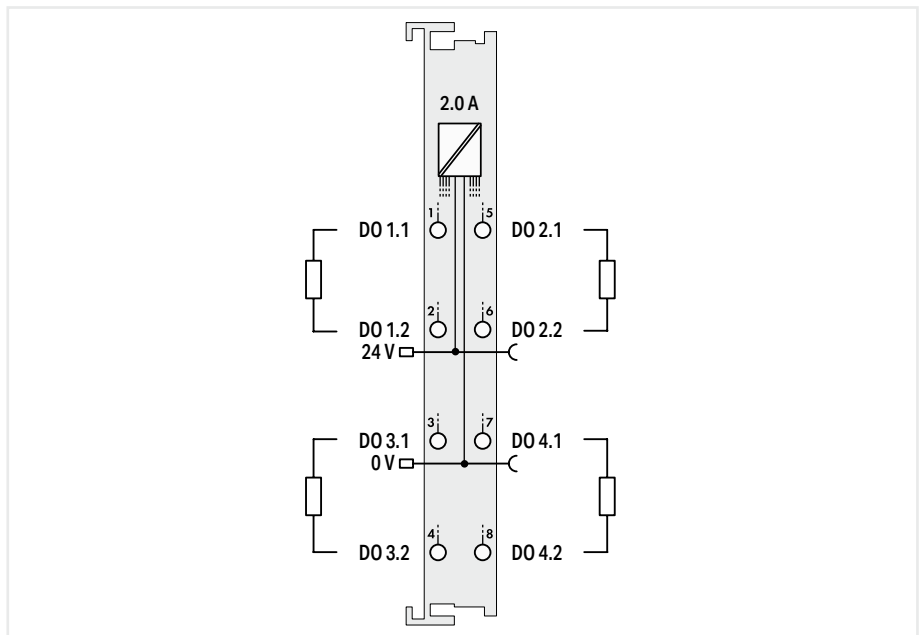

Item description	4-Channel Digital Output; 30 VAC/VDC; 2.0 A; Solid-state; isolated
Version	Standard
Item no.	750-528
Order Text	4DO; 30V AC/DC; 2.0A; SSR; Isolated
Technical data	
Pluggable connector	fixed
Number of digital outputs	4
Signal type	Digital
Signal type (voltage)	30 VAC/DC
Output characteristic	high-side switching
Output current per channel	2 A
Output current (module)	8 A
Output current	requires external fuses
Delay time T _{off} from 1 to 0	20000 µs
Delay time T _{on} from 0 to 1	1000 µs
Load type	Resistive; inductive (Limit induction voltage peaks externally)
Actuator connection	4 x (2-wire)
Switching frequency (max.)	1 Hz
Supply voltage (field)	30 VSELV AC/DC; via power jumper contacts (power supply via blade contact; transmission via spring contact)
Current consumption, field supply (module with no external load)	0 mA
Current consumption (5 V system supply)	57 mA
Output data width (internal) max.	4 bits
Isolation	500 V system/field or channel/channel
Overvoltage category	II
Ambient temperature (operation)	0 ... +55 °C
Dimensions W x H x D	(12 x 100 x 69.8) mm
Approvals	CE; OrdLoc/HazLoc

For data sheet and additional information, see:

wago.com/750-528

Notice: A suitable supply module (e.g., 750-612) must be provided for AC operation or when using DC voltages >31.2 V!

Digital output ▶ 5 ... 250 VAC ▶ high-side switching ▶ 0.25 A



753-540

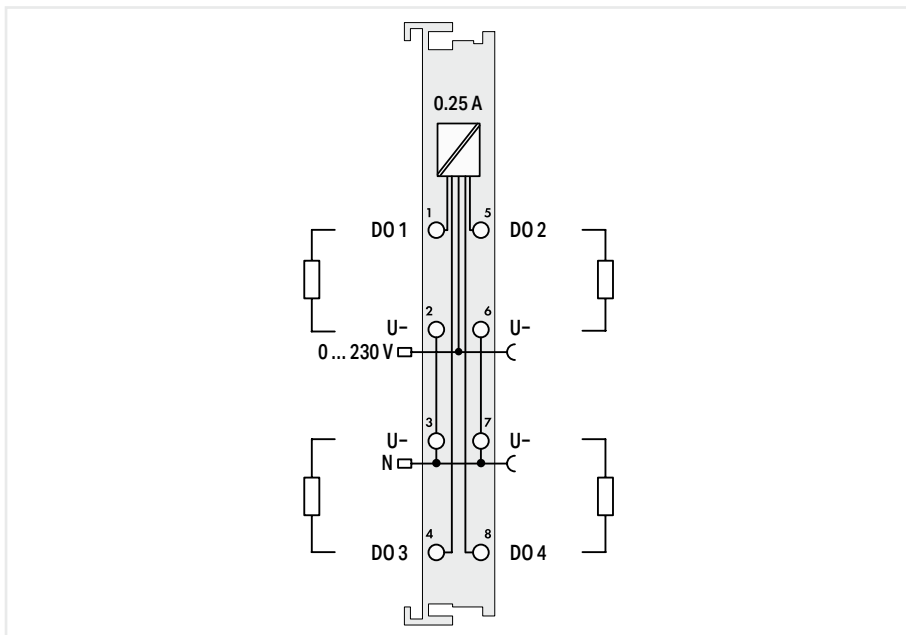

Item description	4-Channel Digital Output; 230 VAC; 0.25 A; Solid-state
Version	pluggable (delivery without connector)
Item no.	753-540
Order Text	4DO; 230 VAC; 0.25A; SSR
Technical data	
Pluggable connector	pluggable
Number of digital outputs	4
Signal type	Digital
Signal type (voltage)	5 ... 250 VAC
Output characteristic	high-side switching
Output current per channel	0.25 A
Output current	short-circuit-protected
Load type	Resistive, inductive
Actuator connection	4 x (2-wire)
Protection against incorrect wiring	Overvoltage protection (275 V) via varistor
Short-circuit current	max. 10 A (16 ms)
Supply voltage (field)	230 VAC; via power jumper contacts (power supply via blade contact; transmission via spring contact)
Current consumption (5 V system supply)	18 mA
Output data width (internal) max.	4 bits
Isolation	1500 V (system/field)
Ambient temperature (operation)	0 ... +55 °C
Dimensions W x H x D	(12 x 100 x 69.8) mm
Approvals	CE, OrdLoc/HazLoc, ATEX/IECEX
For data sheet and additional information, see:	wago.com/753-540
Accessories	
Plug	753-110

Notice: An additional supply module must be added for 0–250 VAC supply!

Digital output ▶ 0 ... 250 VAC/DC ▶ non-floating ▶ 0.3 A



750-509

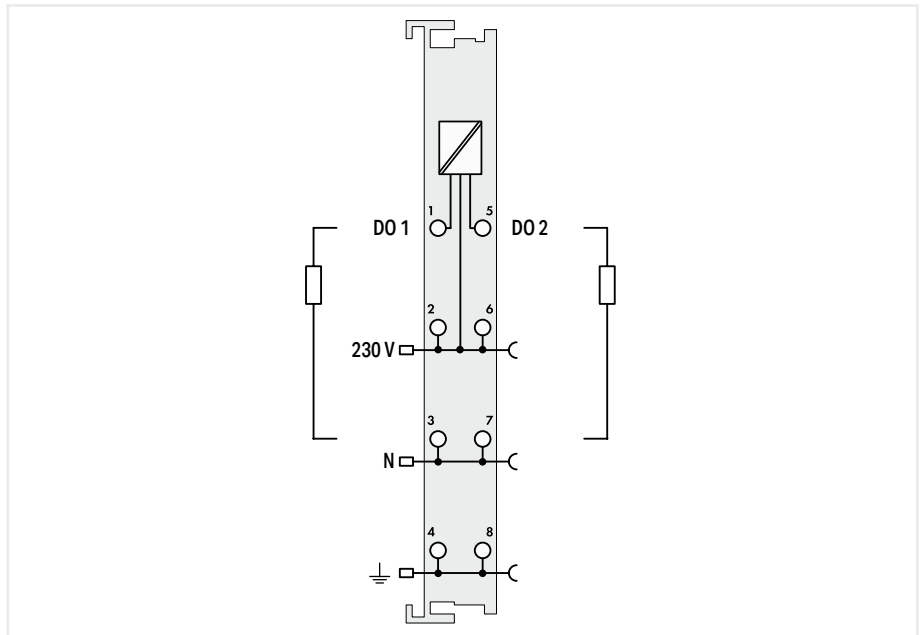

Item description	2-Channel Digital Output; 230 VAC; 0.3 A; Solid-state	
Version	Standard	pluggable (delivery without connector)
Item no.	750-509	753-509
Order Text	2DO; 230 VAC; 0.3A; SSR	2DO; 230 VAC; 0.3A; SSR
Technical data	fixed	pluggable
Pluggable connector		
Number of digital outputs	2	
Signal type	Digital	
Signal type (voltage)	0 ... 250 VAC/DC	
Output circuit design	Solid-state load relays	
Output characteristic	non-floating	
Output current per channel	0.3 A	
Load type	Resistive, inductive	
Actuator connection	2 x (2-wire, 3-wire)	
Switching frequency (max.)	5 Hz; 24 V; 0.3 A; DF = 50 %	
Protection against incorrect wiring	Overvoltage protection (275 V) via varistor	
Supply voltage (field)	250 VAC/DC; via power jumper contacts (power supply via blade contact; transmission via spring contact)	
Current consumption (5 V system supply)	10 mA	
Output data width (internal) max.	2 bits	
Isolation	1500 V (system/field)	
Ambient temperature (operation)	0 ... +55 °C	
Dimensions W x H x D	(12 x 100 x 69.8) mm	
Approvals	CE; Marine; OrdLoc/HazLoc; ATEX/IECEx	
For data sheet and additional information, see:	wago.com/750-509	wago.com/753-509
Accessories	Item no.	Item no.
Plug	-	753-110

Notice: An additional supply module must be added for 0–230 VAC/DC supply!

Digital output; Relay output ▶ Switching voltage: 125 VAC; 30 VDC ▶ potential-free



750-514

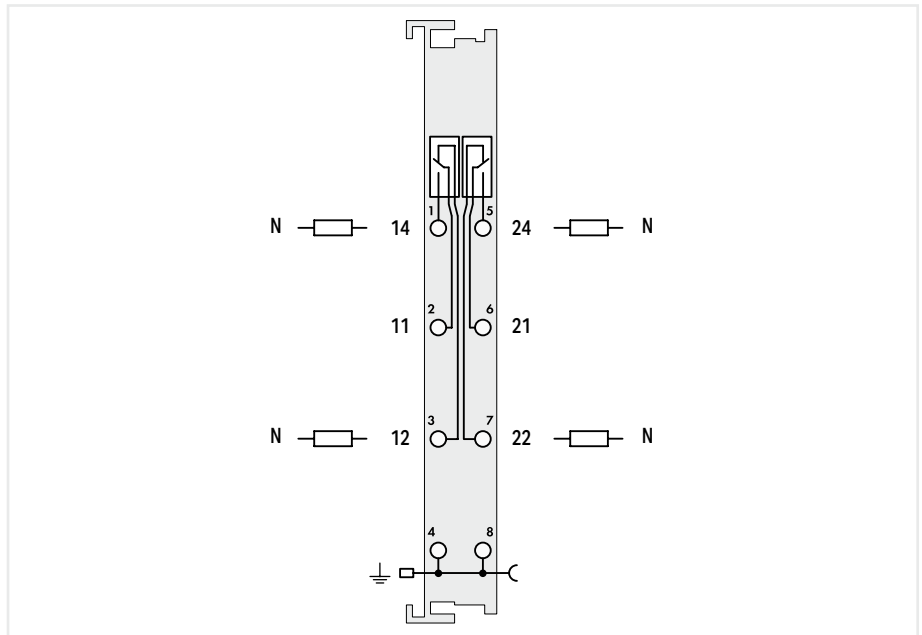

Item description	2-Channel Relay Output; 125 VAC; 0.5 A; Potential-free; 2 changeover contacts	
Version	Standard	pluggable (delivery without connector)
Item no.	750-514	753-514
Order Text	2RO; 125 VAC; 0.5A; Pot-free; Relay2NO	2RO; 125 VAC; 0.5A; Pot-free; Relay2NO

Technical data		
	fixed	pluggable
Pluggable connector		
Number of digital outputs		2
Signal type	Digital	
Switching voltage (max.)	125 VAC, 30 VDC	
Output circuit design	2 changeover contacts; Relay	
Output characteristic	potential-free	
Switching current (max.)	0.5 A	
Switching current (note)	0.5 A at 125 VAC; 1 A at 30 VDC	
Switching current (min.)	0.01 mA	
Actuator connection	2 x (1-wire)	
Switching frequency (max.)	0.33 Hz	
Mechanical switching operations (min.) (at max. resistive load)	100 x 10 ⁶ switching operations	
Electrical switching operations (min.) (at max. resistive load)	100 x 10 ³ switching operations	
Supply voltage (field)	Transmission of ground potential via power jumper contact	
Current consumption (5 V system supply)	70 mA	
Output data width (internal) max.	2 bits	
Isolation	1500 V (system/field)	
Ambient temperature (operation)	0 ... +55 °C	
Dimensions W x H x D	(12 x 100 x 69.8) mm	
Approvals	CE, Marine,	
For data sheet and additional information, see:	wago.com/750-514	wago.com/753-514
Accessories	Item no.	Item no.
Plug	-	753-110

Digital output; Relay output ▶ Switching voltage: 250 VAC; 300 VDC ▶ potential-free



750-517

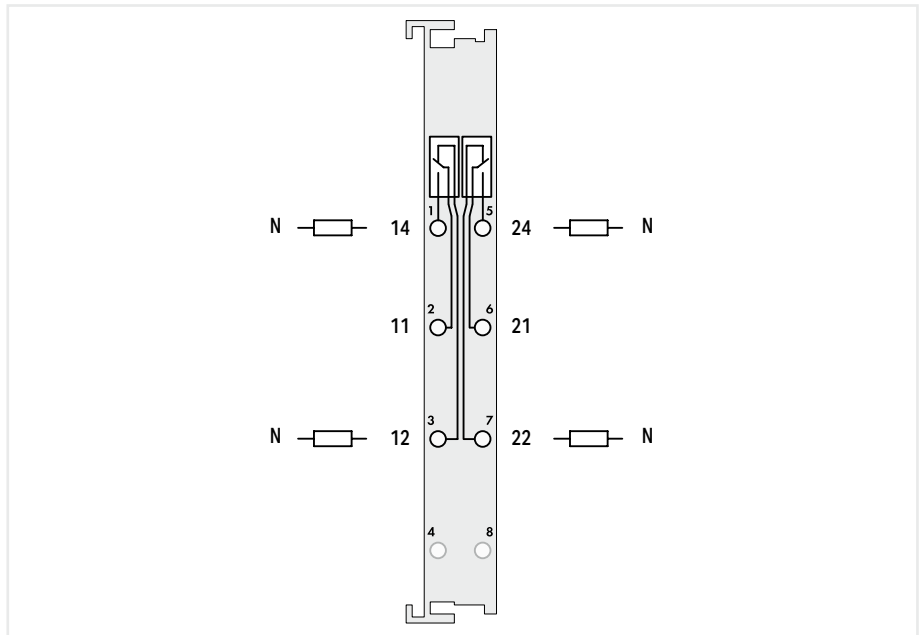

Item description	2-Channel Relay Output; 250 VAC; 0.5 A; Potential-free; 2 changeover contacts	
Version	Standard	pluggable (delivery without connector)
Item no.	750-517	753-517
Order Text	2RO; 250 VAC; 1A; Pot-free; Relay2CO	2RO; 250 VAC; 1A; Pot-free; Relay2CO

Technical data		
	fixed	pluggable
Pluggable connector		
Number of digital outputs	2	
Signal type	Digital	
Switching voltage (max.)	250 VAC, 300 VDC	
Output circuit design	2 changeover contacts; Relay	
Output characteristic	potential-free	
Switching current (max.)	1 A	
Switching current (note)	1 A at 250 VAC and 40 VDC; 0.15 A at 300 VDC	
Switching current (min.)	100 mA	
Actuator connection	2 x (1-wire)	
Switching frequency (max.)	0.1 Hz; Nominal load	
Mechanical switching operations (min.) (at max. resistive load)	5 x 10 ⁶ switching operations	
Electrical switching operations (min.) (at max. resistive load)	1 x 10 ⁶ switching operations	
Current consumption (5 V system supply)	90 mA	
Output data width (internal) max.	2 bits	
Isolation	1500 V (system/field)	
Ambient temperature (operation)	0 ... +55 °C	
Dimensions W x H x D	(12 x 100 x 67.8) mm	(12 x 100 x 69.8) mm
Approvals	CE; Marine; OrdLoc/HazLoc; ATEX/IECEx	
For data sheet and additional information, see:	wago.com/750-517	wago.com/753-517
Accessories	Item no.	Item no.
Plug	-	753-110

7.3

Digital output; Relay output ▶ Switching voltage: 250 VAC; 30 VDC ▶ non-floating



750-512

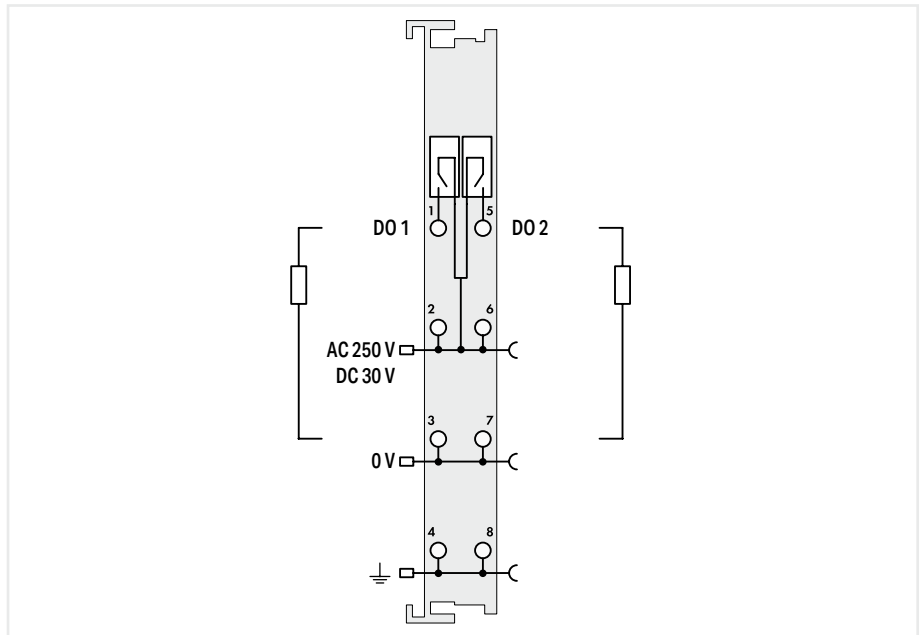

Item description	2-Channel Relay Output; 250 VAC; 2.0 A; 2 make contacts	
Version	Standard	pluggable (delivery without connector)
Item no.	750-512	753-512
Order Text	2RO; 250 VAC; 2A; Relay2NO	2RO; 250 VAC; 2A; Relay2NO

Technical data		
	fixed	pluggable
Pluggable connector		
Number of digital outputs		2
Signal type	Digital	
Switching voltage (max.)	250 VAC, 30 VDC	
Output circuit design	2 make contacts; Relay	
Output characteristic	non-floating	
Switching current (max.)	2 A	
Switching current (min.)	10 mA	
Actuator connection	2 x (2-wire, 3-wire)	
Switching frequency (max.)	0.5 Hz; Nominal load	
Mechanical switching operations (min.) (at max. resistive load)	20 x 10 ⁶ switching operations	
Electrical switching operations (min.) (at max. resistive load)	300 x 10 ³ switching operations	
Supply voltage (field)	250 VAC; via power jumper contacts (power supply via blade contact; transmission via spring contact)	
Current consumption (5 V system supply)	100 mA	
Output data width (internal) max.	2 bits	
Isolation	1500 V (system/field)	
Ambient temperature (operation)	0 ... +55 °C	
Dimensions W x H x D	(12 x 100 x 69.8) mm	
Approvals		
For data sheet and additional information, see:	wago.com/750-512	wago.com/753-512
Accessories	Item no.	Item no.
Plug	-	753-110

Notice: An additional supply module must be added for 0–250 VAC/0–30 VDC supply!

Digital output; Relay output ▶ Switching voltage: 250 VAC; 30 VDC ▶ potential-free



750-513

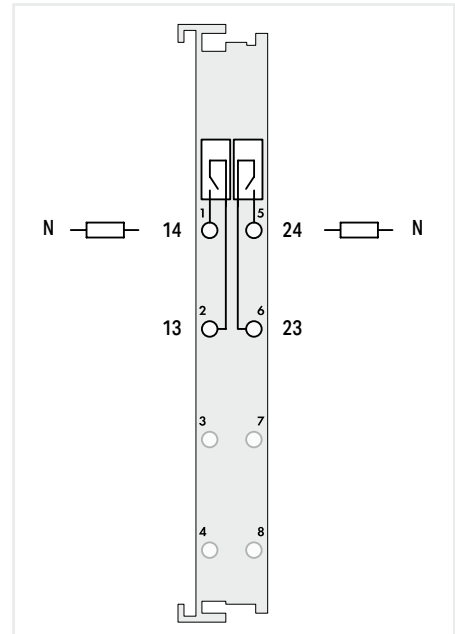
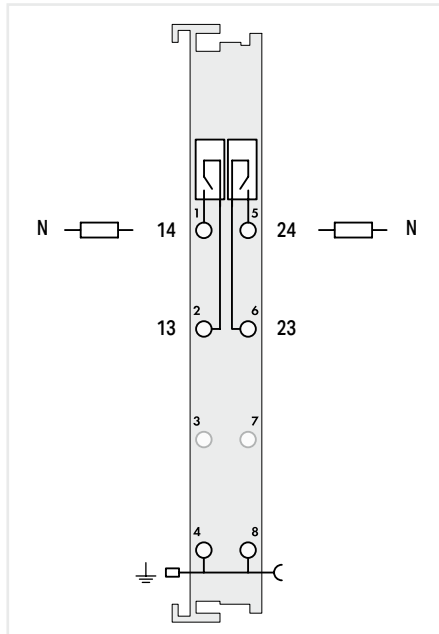

Item description	2-Channel Relay Output; 250 VAC; 2.0 A; Potential-free; 2 make contacts		2-Channel Relay Output; 250 VAC; 2.0 A; Potential-free; 2 make contacts; without power jumper contacts	
Version	Standard	pluggable (delivery without connector)	without power jumper contacts	without power jumper contacts; pluggable (delivery without connector)
Item no.	750-513	753-513	750-513/000-001	753-513/000-001
Order Text	2RO; 250 VAC; 2A; Pot-free; Relay2NO	2RO; 250 VAC; 2A; Pot-free; Relay2NO	2RO; 250 VAC; 2A; Pot-free; NC; Relay2NO	2RO; 250 VAC; 2A; Pot-free; NC; Relay2NO

Technical data				
	fixed	pluggable	fixed	pluggable
Pluggable connector				
Number of digital outputs	2		2	
Signal type	Digital		Digital	
Switching voltage (max.)	250 VAC, 30 VDC		250 VAC, 30 VDC	
Output circuit design	2 make contacts; Relay		2 make contacts; Relay	
Output characteristic	potential-free		potential-free	
Switching current (max.)	2 A		2 A	
Switching current (min.)	10 mA		10 mA	
Actuator connection	2 x (1-wire)		2 x (1-wire)	
Switching frequency (max.)	0.5 Hz; Nominal load		0.5 Hz; Nominal load	
Mechanical switching operations (min.) (at max. resistive load)	20 x 10 ⁶ switching operations		20 x 10 ⁶ switching operations	
Electrical switching operations (min.) (at max. resistive load)	300 x 10 ³ switching operations		300 x 10 ³ switching operations	
Supply voltage (field)	Transmission of ground potential via power jumper contact		-	
Current consumption (5 V system supply)	100 mA		100 mA	
Output data width (internal) max.	2 bits		2 bits	
Isolation	1500 V (system/field)		1500 V (system/field)	
Ambient temperature (operation)	0 ... +55 °C		0 ... +55 °C	
Dimensions W x H x D	(12 x 100 x 69.8) mm		(12 x 100 x 69.8) mm	
Approvals	CE; Marine; OrdLoc/HazLoc; ATEX/IECEX		CE; Marine; OrdLoc/HazLoc; ATEX/IECEX	
For data sheet and additional information, see:	wago.com/750-513		wago.com/753-513	
Accessories	Item no.	Item no.	Item no.	Item no.
Plug	-	753-110	-	753-110

7.3

Digital output; Relay output ► Switching voltage: 250 VAC; 30 VDC; 110 VDC at 0.4 A ► potential-free



750-515

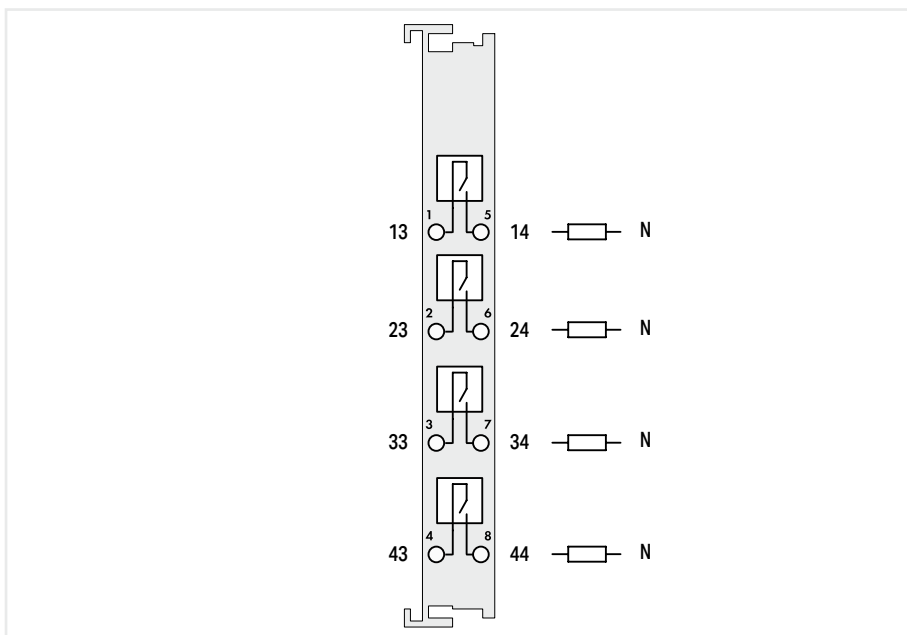

Item description	4-Channel Relay Output; 250 VAC; 2.0 A; Potential-free; 4 make contacts
Version	Standard
Item no.	750-515
Order Text	4RO; 250 VAC; 2A; Pot-free; Relay4NO
Technical data	
Pluggable connector	fixed
Number of digital outputs	4
Signal type	Digital
Switching voltage (max.)	250 VAC; 30 VDC; 110 VDC at 0.4 A
Output circuit design	4 make contacts; Relay
Output characteristic	potential-free
Switching current (max.)	2 A
Switching current (note)	5 A for single-channel use
Actuator connection	4 x (1-wire)
Switching frequency (max.)	0.33 Hz; 3 A / 250 VAC, 30 VDC
Mechanical switching operations (min.) (at max. resistive load)	20 x 10 ⁶ switching operations
Electrical switching operations (min.) (at max. resistive load)	100 x 10 ³ switching operations
Current consumption (5 V system supply)	95 mA
Output data width (internal) max.	4 bits
Isolation	1500 V (system/field)
Ambient temperature (operation)	0 ... +55 °C
Dimensions W x H x D	(12 x 100 x 67.8) mm
Approvals	CE; Marine; OrdLoc/HazLoc; ATEX/IECEX
For data sheet and additional information, see:	wago.com/750-515

Digital output; Relay output ▶ Switching voltage: 440 VAC ▶ potential-free



750-523

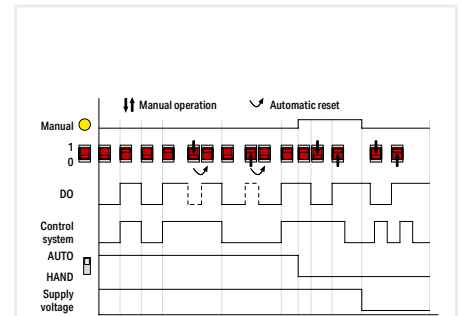
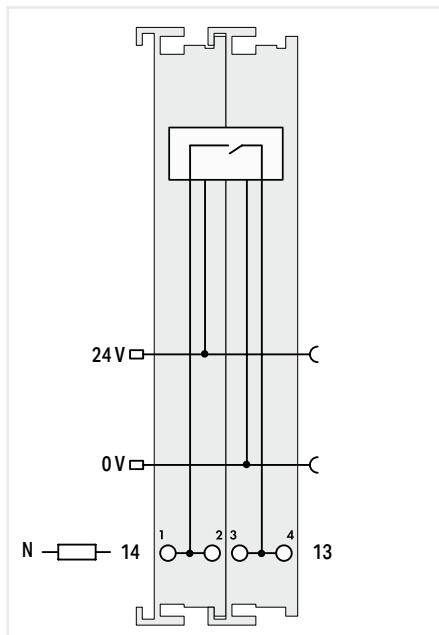

Item description	1-Channel Relay Output; 250 VAC; 16 A; Potential-free; 1 make contact
Version	Standard
Item no.	750-523
Order Text	1RO; 230 VAC; 16A; Pot-free; Relay1NO
Technical data	
Pluggable connector	fixed
Number of digital outputs	1
Signal type	Digital
Switching voltage (max.)	440 VAC
Output circuit design	1 make contact; Relay
Output characteristic	potential-free
Switching current (max.)	16 A
Actuator connection	1 x (1-wire)
Supply voltage (field)	24 VDC (-25 ... +30 %); via power jumper contacts (power supply via blade contact; transmission via spring contact)
Current consumption, field supply (module with no external load)	80 mA
Current consumption (5 V system supply)	5 mA
Input data width (internal) max.	2 bits
Output data width (internal) max.	2 bits
Isolation	1500 V (system/field)
Ambient temperature (operation)	0 ... +55 °C
Dimensions W x H x D	(24 x 100 x 67.8) mm
Approvals	CE; Marine; OrdLoc
For data sheet and additional information, see:	wago.com/750-523

This relay output module switches a connected actuator or load. The 24 VDC supply is derived from the power jumper contacts to trigger the relays. The switched status of the relay is shown by the manual switch (1/0). The operating mode can be set using a manual/automatic selector switch. The mode status is indicated by an LED and via status bits in the process image.

Manual: Coil triggering is interrupted. Operation is only possible via the red manual operating switch.

Auto: The relay is operated via the control system; manual status transitions via the manual switch are reset by the control system after less than 500 ms.

The manual switch can also be used without 24 V supply to switch the output ON. The relay meets both international standards of IEC and DIN EN 61810 part 1 /VDE 0435 part 201, as well as overload and short circuit requirements of IEC and DIN EN 61036 /61037.

Analog Input Modules



Housing Design (750 Series)

Dimensions W x H x D	Housing with 4 LEDs: 12 x 100 x 69.8 mm Housing with 8 LEDs: 12 x 100 x 67.8 mm
Depth from upper edge of DIN-rail	Housing with 4 LEDs: 62.6 mm Housing with 8 LEDs: 60.6 mm
Connection technology	CAGE CLAMP®
Conductor cross-section	0.08 ... 2.5 mm ² / 28 ... 14 AWG
Strip length	8 ... 9 mm / 0.33 inch

Housing Design (753 Series)

Dimensions W x H x D	Housing with 4 LEDs: 12 x 100 x 69.8 mm Housing with 8 LEDs: 12 x 100 x 69 mm
Depth from upper edge of DIN-rail	Housing with 4 LEDs: 62.6 mm Housing with 8 LEDs: 61.8 mm
Connection technology	CAGE CLAMP®
Conductor cross-section	0.08 ... 2.5 mm ² / 28 ... 14 AWG
Strip length	9 ... 10 mm / 0.37 inch

Housing Design (750 Series), Double Width

Dimensions W x H x D	24 x 100 x 67.8 mm
Depth from upper edge of DIN-rail	60.6 mm

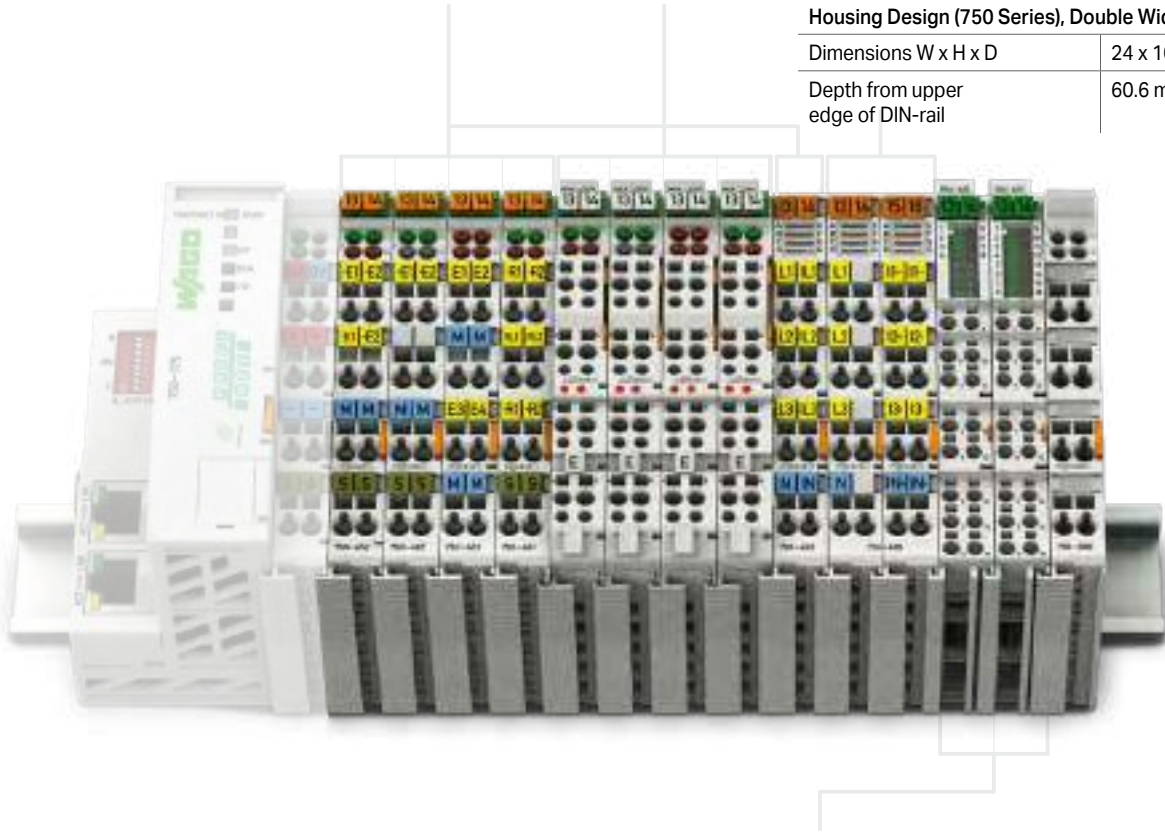

Housing Design (750 Series), with Push-in CAGE CLAMP® Connections (up to 16 connection points)

Dimensions W x H x D	12 x 100 x 69 mm
Depth from upper edge of DIN-rail	61.8 mm
Connection technology	Push-in CAGE CLAMP®
Conductor cross-section	Solid: 0.08 ... 1.5 mm ² / 28 ... 16 AWG Fine-stranded: 0.25 ... 1.5 mm ² / 22 ... 16 AWG
Strip length	8 ... 9 mm / 0.33 inch



I/O System –
750 XTR Series



I/O System – 750 and 753 Series, Analog Input Modules

Contents

Function	1-Channel AI	2-Channel AI	4-Channel AI	8-Channel AI	Description	Item Number				Page
						Standard	/S5 Customized Data Format	Extended Temperature	Pluggable	
0 ... 20 mA	<input type="checkbox"/>	<input type="checkbox"/>	<input type="checkbox"/>	<input type="checkbox"/>	2-Channel Analog Input; 0 ... 20 mA; Differential Input	750-452	750-452/000-200		753-452	312
	<input type="checkbox"/>	<input type="checkbox"/>	<input type="checkbox"/>	<input type="checkbox"/>	2-Channel Analog Input; 0 ... 20 mA; Differential Input	750-480			753-480	313
	<input type="checkbox"/>	<input type="checkbox"/>	<input type="checkbox"/>	<input type="checkbox"/>	2-Channel Analog Input; 0 ... 20 mA; Single-Ended	750-465		750-465/025-000	753-465	314
	<input type="checkbox"/>	<input type="checkbox"/>	<input type="checkbox"/>	<input type="checkbox"/>	2-Channel Analog Input; 0 ... 20 mA; Single-Ended 2-Channel Analog Input; 0 ... 20 mA; Single-Ended; 60 Hz	750-470 750-470/005-000				315
	<input type="checkbox"/>	<input type="checkbox"/>	<input type="checkbox"/>	<input type="checkbox"/>	2-Channel Analog Input; 0 ... 20 mA; Single-Ended; 16 Bits	750-472			753-472	316
	<input type="checkbox"/>	<input type="checkbox"/>	<input type="checkbox"/>	<input type="checkbox"/>	4-Channel Analog Input; 0 ... 20 mA; Single-Ended	750-453*			753-453	317
4 ... 20 mA	<input type="checkbox"/>	<input type="checkbox"/>	<input type="checkbox"/>	<input type="checkbox"/>	2-Channel Analog Input; 4 ... 20 mA; Differential Input 2-Channel Analog Input; 4 ... 20 mA; Differential Input; Ext. Measurement Range	750-454 750-454/000-003	750-454/000-200	750-454/025-000 750-454/025-003	753-454	318
	<input type="checkbox"/>	<input type="checkbox"/>	<input type="checkbox"/>	<input type="checkbox"/>	2-Channel Analog Input; 4 ... 20 mA; Differential Input	750-492*			753-492	320
	<input type="checkbox"/>	<input type="checkbox"/>	<input type="checkbox"/>	<input type="checkbox"/>	2-Channel Analog Input; 4 ... 20 mA; Single-Ended	750-466	750-466/000-200	750-466/025-000	753-466	321
	<input type="checkbox"/>	<input type="checkbox"/>	<input type="checkbox"/>	<input type="checkbox"/>	2-Channel Analog Input; 4 ... 20 mA; Single-Ended 2-Channel Analog Input; 4 ... 20 mA; Single-Ended; 60 Hz	750-473 750-473/005-000				322
	<input type="checkbox"/>	<input type="checkbox"/>	<input type="checkbox"/>	<input type="checkbox"/>	2-Channel Analog Input; 4 ... 20 mA HART	750-482 750-482/000-001		750-482/025-000	753-482	323 324
	<input type="checkbox"/>	<input type="checkbox"/>	<input type="checkbox"/>	<input type="checkbox"/>	2-Channel Analog Input; 4 ... 20 mA; Single-Ended; 16 Bits 2-Channel Analog Input; 4 ... 20 mA; Single-Ended; 16 Bits; 60 Hz	750-474 750-474/005-000	750-474/000-200		753-474	325
	<input type="checkbox"/>	<input type="checkbox"/>	<input type="checkbox"/>	<input type="checkbox"/>	4-Channel Analog Input; 4 ... 20 mA; Single-Ended	750-455*		750-455/025-000	753-455	326
	<input type="checkbox"/>	<input type="checkbox"/>	<input type="checkbox"/>	<input type="checkbox"/>	4-Channel Analog Input; 4 ... 20 mA; Single-Ended; 4 x 24 V	750-455/020-000				326
0/4 ... 20 mA	<input type="checkbox"/>	<input type="checkbox"/>	<input type="checkbox"/>	<input type="checkbox"/>	8-Channel Analog Input; 0/4 ... 20 mA; Single-Ended	750-496				328
0 ... 1 A	<input type="checkbox"/>	<input type="checkbox"/>	<input type="checkbox"/>	<input type="checkbox"/>	2-Channel Analog Input; 0 ... 1 VAC/DC; Differential Input	750-475			753-475	329
0 ... 5 A	<input type="checkbox"/>	<input type="checkbox"/>	<input type="checkbox"/>	<input type="checkbox"/>	2-Channel Analog Input; 0 ... 5 VAC/DC; Differential Input	750-475/020-000				330
±10 V	<input type="checkbox"/>	<input type="checkbox"/>	<input type="checkbox"/>	<input type="checkbox"/>	2-Channel Analog Input; ±10 VDC; Differential Input	750-456	750-456/000-200		753-456	331
	<input type="checkbox"/>	<input type="checkbox"/>	<input type="checkbox"/>	<input type="checkbox"/>	2-Channel Analog Input; ±10 VDC; Differential Input	750-479			753-479	332
	<input type="checkbox"/>	<input type="checkbox"/>	<input type="checkbox"/>	<input type="checkbox"/>	2-Channel Analog Input; ±10 VDC; Single-Ended; 16 Bits	750-476	750-476/000-200		753-476	333
	<input type="checkbox"/>	<input type="checkbox"/>	<input type="checkbox"/>	<input type="checkbox"/>	4-Channel Analog Input; ±10 VDC; Single-Ended	750-457*		750-457/025-000	753-457	334
0 ... 10 V	<input type="checkbox"/>	<input type="checkbox"/>	<input type="checkbox"/>	<input type="checkbox"/>	2-Channel Analog Input; 0 ... 10 VDC; Single-Ended	750-467			753-467	335
	<input type="checkbox"/>	<input type="checkbox"/>	<input type="checkbox"/>	<input type="checkbox"/>	2-Channel Analog Input; 0 ... 10 VDC; Single-Ended; 16 Bits 2-Channel Analog Input; 0 ... 10 VDC; Single-Ended; 16 Bits; 60 Hz	750-478 750-478/005-000			753-478	336
	<input type="checkbox"/>	<input type="checkbox"/>	<input type="checkbox"/>	<input type="checkbox"/>	4-Channel Analog Input; 0 ... 10 VDC; Single-Ended	750-468*		750-468/025-000		337
	<input type="checkbox"/>	<input type="checkbox"/>	<input type="checkbox"/>	<input type="checkbox"/>	4-Channel Analog Input; 0 ... 10 VDC; Single-Ended	750-459			753-459	338
0 ... 10 V/±10 V	<input type="checkbox"/>	<input type="checkbox"/>	<input type="checkbox"/>	<input type="checkbox"/>	8-Channel Analog Input; 0 ... 10 VDC/±10 V; Single-Ended	750-497				339
0 ... 10 VAC/DC	<input type="checkbox"/>	<input type="checkbox"/>	<input type="checkbox"/>	<input type="checkbox"/>	2-Channel Analog Input; 0 ... 10 VAC/DC; Differential Input	750-477			753-477	340
0 ... 30 V	<input type="checkbox"/>	<input type="checkbox"/>	<input type="checkbox"/>	<input type="checkbox"/>	2-Channel Analog Input; 0 ... 30 VDC; Differential Input	750-483*			753-483	341
Voltage/Current	<input type="checkbox"/>	<input type="checkbox"/>	<input type="checkbox"/>	<input type="checkbox"/>	4-Channel Analog Input; for Voltage/Current	750-471				342
Resistance Sensors	<input type="checkbox"/>	<input type="checkbox"/>	<input type="checkbox"/>	<input type="checkbox"/>	2-Channel Analog Input; for Pt100/RTD Resistance Sensors	750-461	750-461/000-200	750-461/025-000	753-461	345
	<input type="checkbox"/>	<input type="checkbox"/>	<input type="checkbox"/>	<input type="checkbox"/>	2-Channel Analog Input; for Pt100/RTD Resistance Sensors; Adjustable	750-461/003-000			753-461/003-000	344
	<input type="checkbox"/>	<input type="checkbox"/>	<input type="checkbox"/>	<input type="checkbox"/>	2-Channel Analog Input; for NTC 20k Resistance Sensors	750-461/020-000				343
	<input type="checkbox"/>	<input type="checkbox"/>	<input type="checkbox"/>	<input type="checkbox"/>	2/4-Channel Analog Input; Resistance Measurement; Adjustable	750-464*				346
	<input type="checkbox"/>	<input type="checkbox"/>	<input type="checkbox"/>	<input type="checkbox"/>	4-Channel Analog Input; for NTC Resistance Sensors; Adjustable	750-464/020-000				347
	<input type="checkbox"/>	<input type="checkbox"/>	<input type="checkbox"/>	<input type="checkbox"/>	4-Channel Analog Input; Resistance Measurement; Measurement Range: -30 °C ... +150 °C	750-463				346
Thermocouples	<input type="checkbox"/>	<input type="checkbox"/>	<input type="checkbox"/>	<input type="checkbox"/>	4-Channel Analog Input; Resistance Measurement; Adjustable	750-450				348
	<input type="checkbox"/>	<input type="checkbox"/>	<input type="checkbox"/>	<input type="checkbox"/>	8-Channel Analog Input; Resistance Measurement; Adjustable	750-451		750-451/025-000		349
	<input type="checkbox"/>	<input type="checkbox"/>	<input type="checkbox"/>	<input type="checkbox"/>	2-Channel Analog Input; Thermocouple K; Diagnostics	750-469	750-469/000-200		753-469	350
Analog Specialty Functions	<input type="checkbox"/>	<input type="checkbox"/>	<input type="checkbox"/>	<input type="checkbox"/>	2-Channel Analog Input; Thermocouple K; Diagnostics; Adjustable	750-469/003-000*			753-469/003-000	351
	<input type="checkbox"/>	<input type="checkbox"/>	<input type="checkbox"/>	<input type="checkbox"/>	2-Channel Analog Input; Thermocouple J; Diagnostics	750-469/000-006				351
	<input type="checkbox"/>	<input type="checkbox"/>	<input type="checkbox"/>	<input type="checkbox"/>	8-Channel Analog Input; Thermocouple; Adjustable	750-498				352
	<input type="checkbox"/>	<input type="checkbox"/>	<input type="checkbox"/>	<input type="checkbox"/>	1-Channel Analog Input; Resistor Bridges (Strain Gauges) 1-Channel Analog Input; Resistor Bridges (Strain Gauges); 125 ms	750-491 750-491/000-001				353
	<input type="checkbox"/>	<input type="checkbox"/>	<input type="checkbox"/>	<input type="checkbox"/>	2-Channel Analog Input; Resistor Bridges (Strain Gauges)	750-1491				354
	<input type="checkbox"/>	<input type="checkbox"/>	<input type="checkbox"/>	<input type="checkbox"/>	3-Phase Power Measurement; 480 VAC 1 A 3-Phase Power Measurement; 480 VAC 5 A	750-493 750-493/000-001		750-493/025-000		356
	<input type="checkbox"/>	<input type="checkbox"/>	<input type="checkbox"/>	<input type="checkbox"/>	3-Phase Power Measurement; 480 VAC 1 A 3-Phase Power Measurement; 480 VAC 5 A	750-494 750-494/000-001		750-494/025-000 750-494/025-001		357
	<input type="checkbox"/>	<input type="checkbox"/>	<input type="checkbox"/>	<input type="checkbox"/>	Power Measurement; 277 VAC/DC; External Shunts	750-494/000-005				358
	<input type="checkbox"/>	<input type="checkbox"/>	<input type="checkbox"/>	<input type="checkbox"/>	3-Phase Power Measurement; 690 VAC 1 A 3-Phase Power Measurement; 690 VAC 5 A 3-Phase Power Measurement; 690 VAC Rogowski Coils	750-495* 750-495/000-001* 750-495/000-002*				359
Ex i										See Section 7.9
*This module is also available as a variant of the 750 XTR Series.										See Section 8

Analog input ▶ 0 ... 20 mA ▶ Differential



750-452

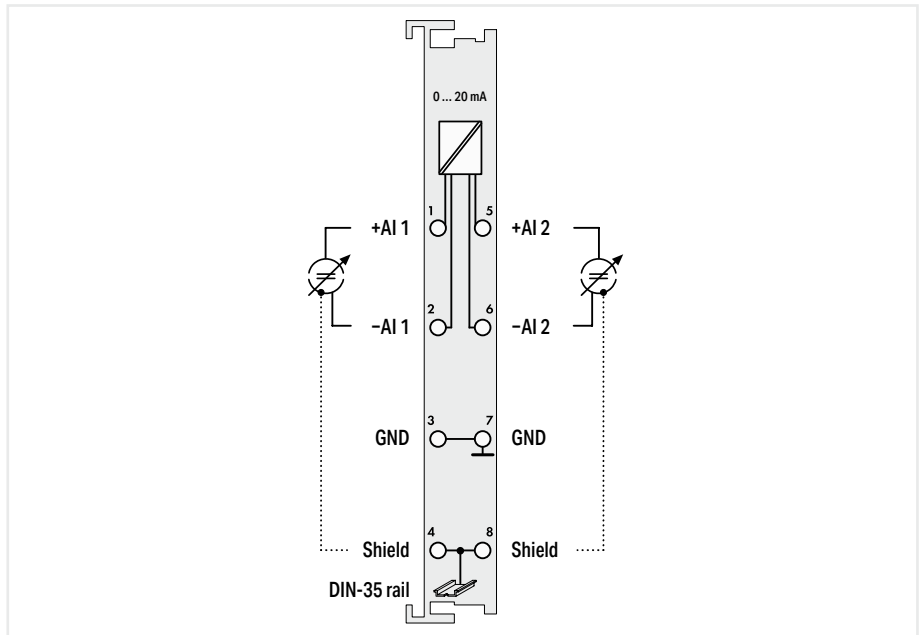

Item description		2-Channel Analog Input; 0 ... 20 mA; Differential Input	
Version		Standard	pluggable (delivery without connector) Data format (S5 control)
Item no.	750-452		753-452 750-452/000-200
Order Text	2AI; 0-20mA; Diff		2AI; 0-20mA; Diff 2AI; 0-20mA; Diff; S5
Technical data			
Pluggable connector	-		pluggable -
Customized data format			The S5 format allows you to import data with the standard S5 FB 250 function block.
Number of analog inputs			2
Signal type			Current
Signal type (current)			0 ... 20 mADC
Signal characteristics			Differential
Sensor connection			2 x (2-wire)
Resolution [bit]			12 bits
Conversion time (typ.)			2 ms
Input resistance (max.)			220 Ω
Input voltage (max.)			35 V
Measurement error (reference temperature)			25 °C
Measurement error, deviation (max.) from the upper-range value			0.2 %
Temperature error (max.) of the upper-range value			0.01 %/K
Current consumption (5 V system supply)			70 mA
Data width			2 x 16-bit data; 2 x 8-bit control/status (optional)
Isolation			500 V system/field
Ambient temperature (operation)			0 ... +55 °C
Dimensions W x H x D			(12 x 100 x 69.8) mm
Approvals			CE; Marine; OrdLoc/HazLoc; ATEX/IECEX
For data sheet and additional information, see:	wago.com/750-452	wago.com/753-452	wago.com/750-452/000-200
Accessories	Item no.	Item no.	Item no.
Plug	-	753-110	-

7.4

Analog input ▶ 0 ... 20 mA ▶ Differential



750-480

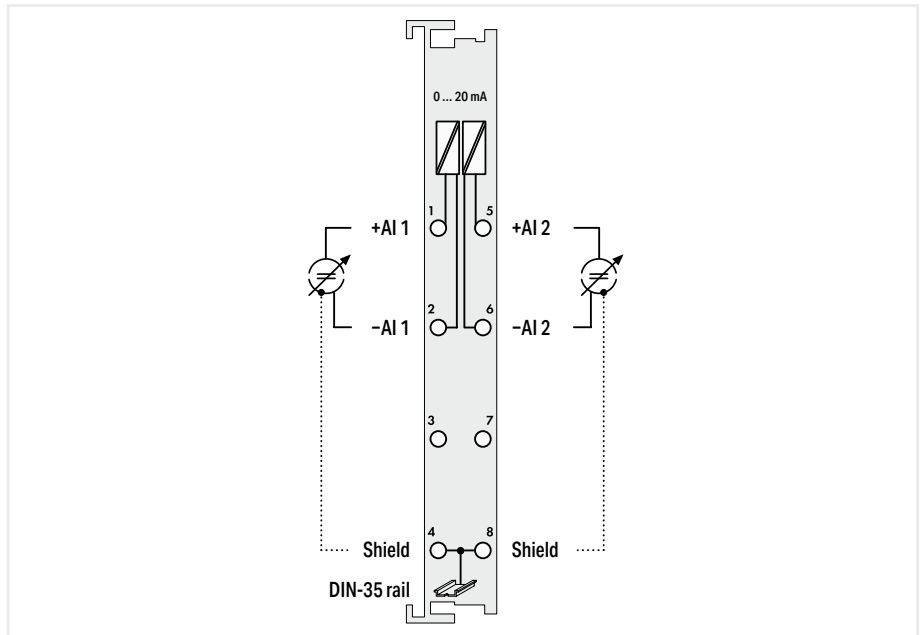

Item description	2-Channel Analog Input; 0 ... 20 mA; Differential Input	
Version	Standard	pluggable (delivery without connector)
Item no.	750-480	753-480
Order Text	2AI; 0-20mA; Diff	2AI; 0-20mA; Diff

Technical data		
Extended functionality	Time-synchronized measured value acquisition within the module	
Pluggable connector	-	pluggable
Number of analog inputs	2	
Signal type	Current	
Signal type (current)	0 ... 20 mADC	
Signal characteristics	Differential	
Sensor connection	2 x (2-wire)	
Resolution [bit]	13 bits	
Input resistance (max.)	270 Ω	
Admissible continuous overload	30 V	
Measurement error (reference temperature)	25 °C	
Measurement error, deviation (max.) from the upper-range value	0.05 %	
Temperature error (max.) of the upper-range value	0.01 %/K	
Current consumption (5 V system supply)	80 mA	
Data width	2 x 16-bit data; 2 x 8-bit control/status (optional)	
Isolation	500 V system/field or channel/channel	
Ambient temperature (operation)	0 ... +55 °C	
Dimensions W x H x D	(12 x 100 x 69.8) mm	
Approvals	CE, OrdLoc/HazLoc, ATEX/IECEx	
For data sheet and additional information, see:	wago.com/750-480	wago.com/753-480

Accessories	Item no.	Item no.
Plug	-	753-110

Analog input ► 0 ... 20 mA ► Single-ended



750-465

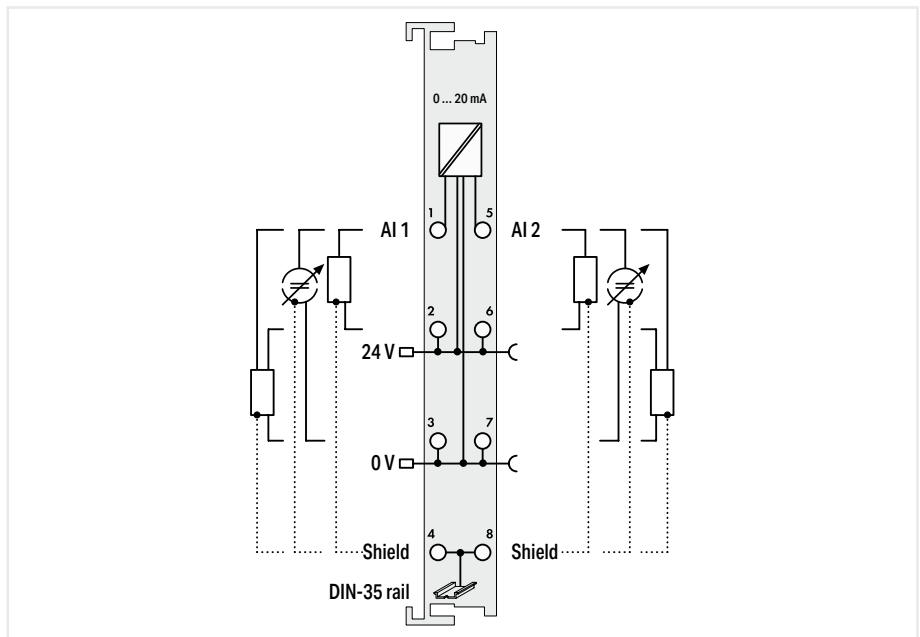

Item description			
Version			
Item no.			
Order Text			
2-Channel Analog Input; 0 ... 20 mA; Single-ended			
Standard	ext. temperature	pluggable (delivery without connector)	
750-465	750-465/025-000	753-465	
2AI; 0-20mA; SE	2AI; 0-20mA; SE; T	2AI; 0-20mA; SE	
Technical data			
Pluggable connector	-		pluggable
Number of analog inputs	2		
Signal type	Current		
Signal type (current)	0 ... 20 mA DC		
Signal characteristics	Single-ended		
Sensor connection	2 x (2-wire, 3-wire)		
Resolution [bit]	12 bits		
Conversion time (typ.)	2 ms		
Input resistance (max.)	220 Ω		
Input voltage (max.)	10 V		
Measurement error (reference temperature)	25 °C		
Measurement error, deviation (max.) from the upper-range value	0.2 %		
Temperature error (max.) of the upper-range value	0.01 %/K		
Supply voltage (field)	24 VDC (-25 ... +30 %); via power jumper contacts (power supply via blade contact; transmission via spring contact)		
Current consumption (5 V system supply)	75 mA		
Data width	2 x 16-bit data; 2 x 8-bit control/status (optional)		
Isolation	500 V system/field		
Ambient temperature (operation)	0 ... +55 °C	-20 ... +60 °C	0 ... +55 °C
Dimensions W x H x D	(12 x 100 x 69.8) mm		
Approvals	CE, OrdLoc/HazLoc, ATEX/IECEx		
For data sheet and additional information, see:	wago.com/750-465		wago.com/753-465
Accessories			
Item no.	Item no.	Item no.	
Plug	-	753-110	

Analog input ▶ 0 ... 20 mA ▶ Single-ended



750-470

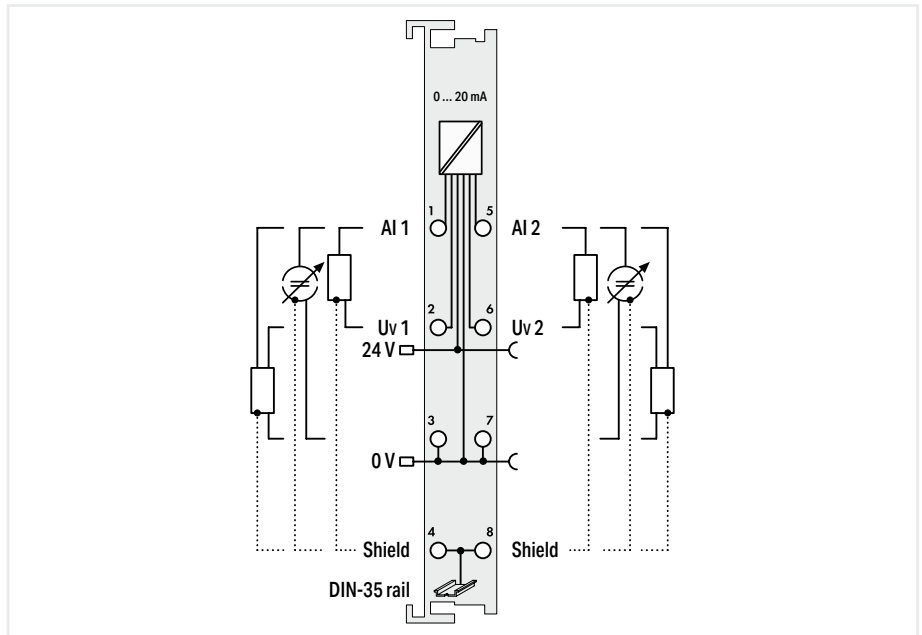

Item description	2-Channel Analog Input; 0 ... 20 mA; Single-ended; Short-circuit-protected sensor supply	
Version	Standard	60 Hz
Item no.	750-470	750-470/005-000
Order Text	2AI; 0-20mA; SE	2AI; 0-20mA; SE; 60Hz

Technical data		
Extended functionality	Short-circuit-protected sensor supply	
Number of analog inputs	2	
Signal type	Current	
Signal type (current)	0 ... 20 mADC	
Signal characteristics	Single-ended	
Sensor connection	2 x (2-wire, 3-wire)	
Resolution [bit]	12 bits	
Conversion time (typ.)	80 ms	
Input resistance (max.)	160 Ω	
Input filter frequency (analog)	50 Hz	60 Hz
Measurement error (reference temperature)	25 °C	
Measurement error, deviation (max.) from the upper-range value	0.1 %	
Temperature error (max.) of the upper-range value	0.01 %/K	
Supply voltage (field)	24 VDC (-25 ... +30 %); via power jumper contacts (power supply via blade contact; transmission via spring contact)	
Current consumption (5 V system supply)	100 mA	
Data width	2 x 16-bit data; 2 x 8-bit control/status (optional)	
Isolation	500 V system/field	
Ambient temperature (operation)	0 ... +55 °C	
Dimensions W x H x D	(12 x 100 x 69.8) mm	
Approvals		

For data sheet and additional information, see:

wago.com/750-470

Analog input ▶ 0 ... 20 mA ▶ Single-ended



750-472

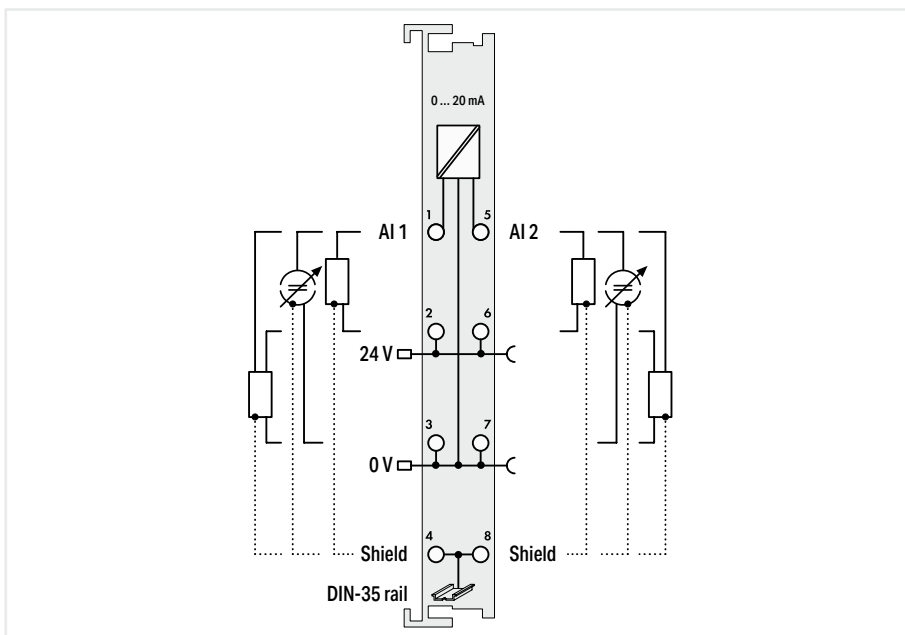

Item description	2-Channel Analog Input; 0 ... 20 mA; Single-ended; 16 bits	
Version	Standard	pluggable (delivery without connector)
Item no.	750-472	753-472
Order Text	2AI; 0-20mA; SE; 16bits	2AI; 0-20mA; SE; 16bits
Technical data		
Extended functionality	Overload protection	
Pluggable connector	-	pluggable
Number of analog inputs	2	
Signal type	Current	
Signal type (current)	0 ... 20 mADC	
Signal characteristics	Single-ended	
Sensor connection	2 x (2-wire, 3-wire)	
Resolution [bit]	15 bits	
Conversion time (typ.)	80 ms	
Input resistance (max.)	220 Ω	
Input voltage (max.)	24 V	
Input filter frequency (analog)	50 Hz	
Measurement error (reference temperature)	25 °C	
Measurement error, deviation (max.) from the upper-range value	0.1 %	
Temperature error (max.) of the upper-range value	0.01 %/K	
Supply voltage (field)	24 VDC (-25 ... +30 %); via power jumper contacts (power supply via blade contact; transmission via spring contact)	
Current consumption (5 V system supply)	75 mA	
Data width	2 x 16-bit data; 2 x 8-bit control/status (optional)	
Isolation	500 V system/field	
Ambient temperature (operation)	0 ... +55 °C	
Dimensions W x H x D	(12 x 100 x 69.8) mm	
Approvals	CE; Marine; OrdLoc/HazLoc; ATEX/IECEX	
For data sheet and additional information, see:	wago.com/750-472	wago.com/753-472
Accessories	Item no.	Item no.
Plug	-	753-110

Analog input ▶ 0 ... 20 mA ▶ Single-ended



750-453

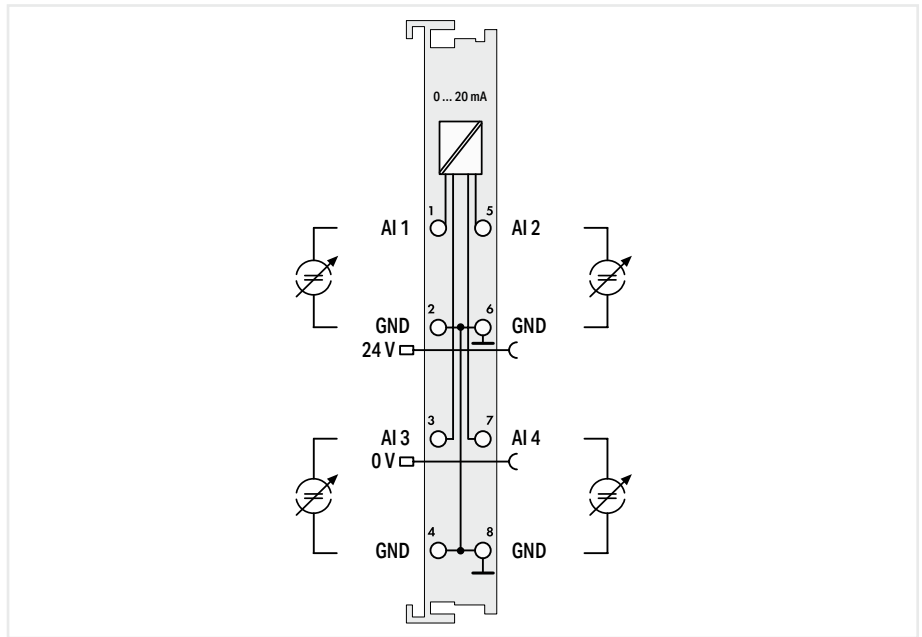

Item description	4-Channel Analog Input; 0 ... 20 mA; Single-ended	
Version	Standard	pluggable (delivery without connector)
Item no.	750-453	753-453
Order Text	4AI; 0-20mA; SE	4AI; 0-20mA; SE
Technical data		
Pluggable connector	-	pluggable
Number of analog inputs	4	
Signal type	Current	
Signal type (current)	0 ... 20 mADC	
Signal characteristics	Single-ended	
Sensor connection	4 x (2-wire)	
Resolution [bit]	12 bits	
Conversion time (typ.)	10 ms	
Input resistance (max.)	100 Ω	
Input voltage (max.)	32 V	
Measurement error (reference temperature)	25 °C	
Measurement error, deviation (max.) from the upper-range value	0.1 %	
Temperature error (max.) of the upper-range value	0.01 %/K	
Supply voltage (field)	24 VDC (-25 ... +30 %); via power jumper contacts (power supply via blade contact; transmission via spring contact)	
Current consumption (5 V system supply)	65 mA	
Data width	4 x 16-bit data; 4 x 8-bit control/status (optional)	
Isolation	500 V system/field	
Ambient temperature (operation)	0 ... +55 °C	
Dimensions W x H x D	(12 x 100 x 69.8) mm	
Approvals	CE; Marine; OrdLoc/HazLoc; ATEX/IECEx	
For data sheet and additional information, see:	wago.com/750-453	wago.com/753-453
Accessories	Item no.	Item no.
Plug	-	753-110

Analog input ▶ 4 ... 20 mA ▶ Differential



750-454

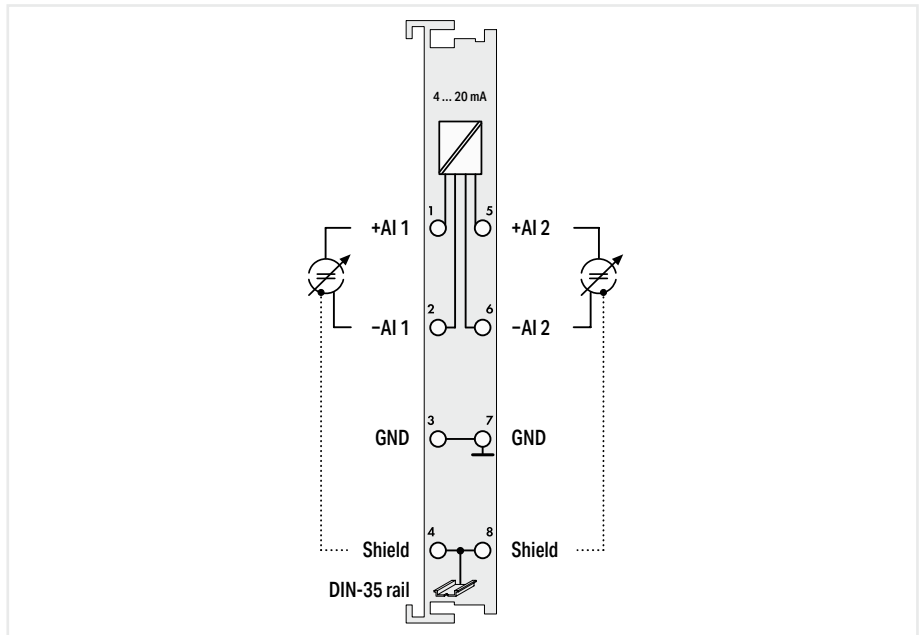

Item description	2-Channel Analog Input; 4 ... 20 mA; Differential input				
Version	Standard	ext. temperature	pluggable (delivery without connector)	Data format (S5 control)	Extended measurement range
Item no.	750-454	750-454/025-000	753-454	750-454/000-200	750-454/000-003
Order Text	2AI; 4-20mA; Diff	2AI; 4-20mA; Diff; T	2AI; 4-20mA; Diff	2AI; 4-20mA; Diff; S5	2AI; 4-20mA; Diff; EM

Technical data					
Pluggable connector	-		pluggable	-	
Customized data format	-			The S5 format allows you to import data with the standard S5 FB 250 function block.	
Number of analog inputs	2				
Signal type	Current				
Signal type (current)	4 ... 20 mADC			3.8 ... 20.5 mADC	
Signal characteristics	Differential				
Sensor connection	2 x (2-wire)				
Resolution [bit]	12 bits				
Conversion time (typ.)	2 ms				
Input resistance (max.)	220 Ω				
Input voltage (max.)	35 V				
Measurement error (reference temperature)	25 °C				
Measurement error, deviation (max.) from the upper-range value	0.2 %				
Temperature error (max.) of the upper-range value	0.01 %/K				
Current consumption (5 V system supply)	70 mA				
Data width	2 x 16-bit data; 2 x 8-bit control/status (optional)				
Isolation	500 V system/field				
Ambient temperature (operation)	0 ... +55 °C	-20 ... +60 °C		0 ... +55 °C	
Dimensions W x H x D	(12 x 100 x 69.8) mm				
Approvals	CE; Marine; OrdLoc/HazLoc; ATEX/IECEx				
For data sheet and additional information, see:	wago.com/750-454		wago.com/753-454	wago.com/750-454/000-200	

Accessories	Item no.	Item no.	Item no.	Item no.	Item no.
Plug	-	-	753-110	-	-

7.4

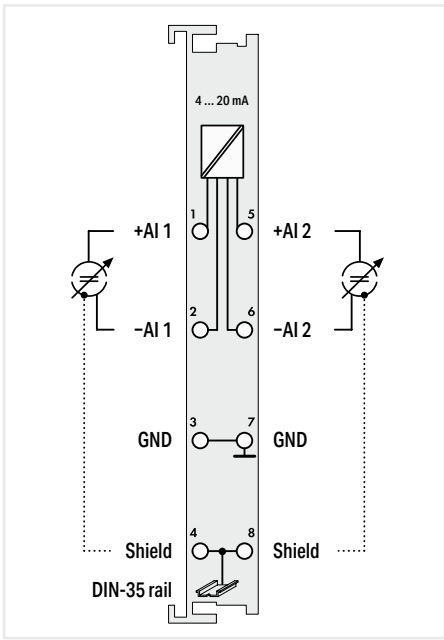

2-Channel Analog Input; 4 ... 20 mA; Differential input
ext. temperature; ext. measurement range

750-454/025-003

2AI; 4-20mA; Diff; EM; T

-
-
2
Current
3.8 ... 20.5 mADC
Differential
2 x (2-wire)
12 bits
2 ms
220 Ω
35 V
25 °C
0.2 %
0.01 %/K
70 mA
2 x 16-bit data; 2 x 8-bit control/status (optional)
500 V system/field
-20 ... +60 °C
(12 x 100 x 69.8) mm
CE; Marine; OrdLoc/HazLoc; ATEX/IECEx
wago.com/750-454/000-200

Item no. -

Analog input ▶ 4 ... 20 mA ▶ Differential



750-492

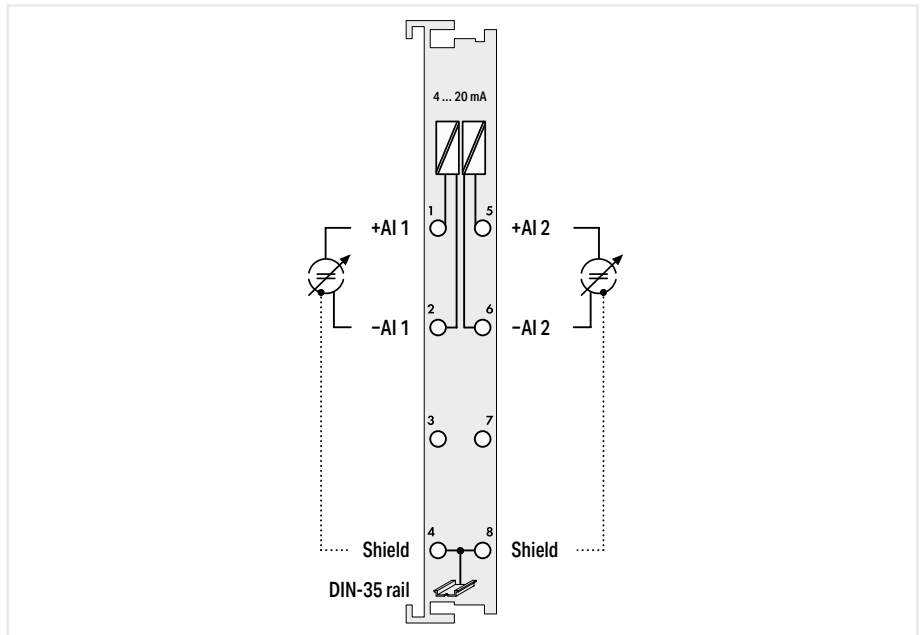

Item description	2-Channel Analog Input; 4 ... 20 mA; Differential input	
Version	Standard	pluggable (delivery without connector)
Item no.	750-492	753-492
Order Text	2AI; 4-20mA; Diff	2AI; 4-20mA; Diff

Technical data		
Extended functionality	Time-synchronized measured value acquisition within the module	
Pluggable connector	-	pluggable
Number of analog inputs	2	
Signal type	Current	
Signal type (current)	4 ... 20 mADC	
Signal characteristics	Differential	
Sensor connection	2 x (2-wire)	
Resolution [bit]	13 bits	
Input resistance (max.)	270 Ω	
Admissible continuous overload	30 V	
Measurement error (reference temperature)	25 °C	
Measurement error, deviation (max.) from the upper-range value	0.05 %	
Temperature error (max.) of the upper-range value	0.01 %/K	
Current consumption (5 V system supply)	80 mA	
Data width	2 x 16-bit data; 2 x 8-bit control/status (optional)	
Isolation	500 V system/field or channel/channel	
Ambient temperature (operation)	0 ... +55 °C	
Dimensions W x H x D	(12 x 100 x 69.8) mm	
Approvals	CE; OrdLoc/HazLoc; ATEX/IECEx	
For data sheet and additional information, see:	wago.com/750-492	wago.com/753-492

Accessories	Item no.	Item no.
Plug	-	753-110

7.4

Analog input ▶ 4 ... 20 mA ▶ Single-ended



750-466

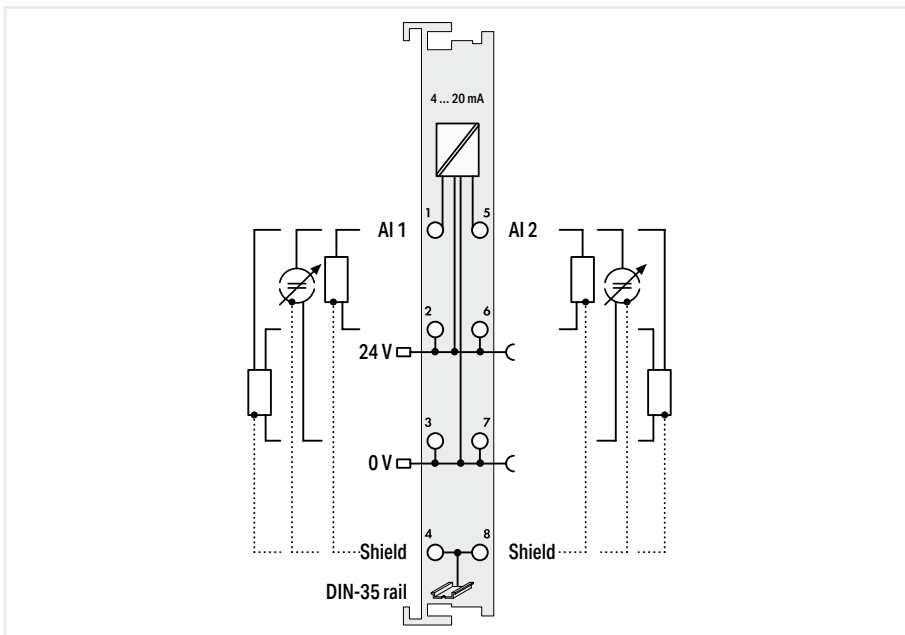

Item description		2-Channel Analog Input; 4 ... 20 mA; Single-ended				
Version	Standard	ext. temperature	pluggable (delivery without connector)	Data format (S5 control)	Extended measurement range	
750-466	750-466	750-466/025-000	753-466	750-466/000-200	750-466/000-003	
Order Text	2AI; 4-20mA; SE	2AI; 4-20mA; SE; T	2AI; 4-20mA; SE	2AI; 4-20mA; SE; S5	2AI; 4-20mA; SE; EM	
Technical data						
Pluggable connector	-	pluggable		-		
Customized data format	-			The S5 format allows you to import data with the standard S5 FB 250 function block.		
Number of analog inputs	2					
Signal type	Current					
Signal type (current)	4 ... 20 mADC				3.8 ... 20.5 mADC	
Signal characteristics	Single-ended					
Sensor connection	2 x (2-wire, 3-wire)					
Resolution [bit]	12 bits					
Conversion time (typ.)	2 ms					
Input resistance (max.)	220 Ω					
Input voltage (max.)	10 V					
Measurement error (reference temperature)	25 °C					
Measurement error, deviation (max.) from the upper-range value	0.2 %					
Temperature error (max.) of the upper-range value	0.01 %/K					
Supply voltage (field)	24 VDC (-25 ... +30 %); via power jumper contacts (power supply via blade contact; transmission via spring contact)					
Current consumption (5 V system supply)	75 mA					
Data width	2 x 16-bit data; 2 x 8-bit control/status (optional)					
Isolation	500 V system/field					
Ambient temperature (operation)	0 ... +55 °C	-20 ... +60 °C	0 ... +55 °C			
Dimensions W x H x D	(12 x 100 x 69.8) mm					
Approvals	CE, OrdLoc/HazLoc, ATEX/IECEx					
For data sheet and additional information, see:	wago.com/750-466	wago.com/753-466	wago.com/750-466/000-200			
Accessories	Item no.	Item no.	Item no.	Item no.	Item no.	
Plug	-	-	753-110	-	-	

Analog input ▶ 4 ... 20 mA ▶ Single-ended



750-473

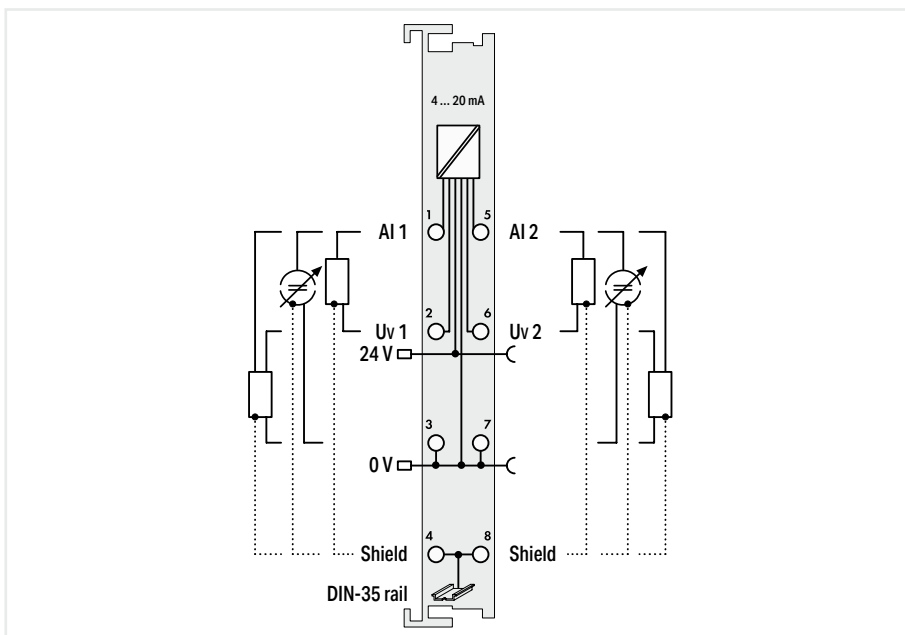

Item description	2-Channel Analog Input; 4 ... 20 mA; Single-ended	
Version	Standard	60 Hz
Item no.	750-473	750-473/005-000
Order Text	2AI; 4-20mA; SE	2AI; 4-20mA; SE; 60Hz

Technical data		
Extended functionality	Short-circuit-protected sensor supply	
Number of analog inputs	2	
Signal type	Current	
Signal type (current)	4 ... 20 mADC	
Signal characteristics	Single-ended	
Sensor connection	2 x (2-wire, 3-wire)	
Resolution [bit]	12 bits	
Conversion time (typ.)	80 ms	
Input resistance (max.)	160 Ω	
Input filter frequency (analog)	50 Hz	60 Hz
Measurement error (reference temperature)	25 °C	
Measurement error, deviation (max.) from the upper-range value	0.1 %	
Temperature error (max.) of the upper-range value	0.01 %/K	
Supply voltage (field)	24 VDC (-25 ... +30 %); via power jumper contacts (power supply via blade contact; transmission via spring contact)	
Current consumption (5 V system supply)	100 mA	
Data width	2 x 16-bit data; 2 x 8-bit control/status (optional)	
Isolation	500 V system/field	
Ambient temperature (operation)	0 ... +55 °C	
Dimensions W x H x D	(12 x 100 x 69.8) mm	
Approvals	CE; Marine; OrdLoc/HazLoc; ATEX/IECEx	
For data sheet and additional information, see:	wago.com/750-473	

Analog input ▶ 4 ... 20 mA ▶ Single-ended



750-482

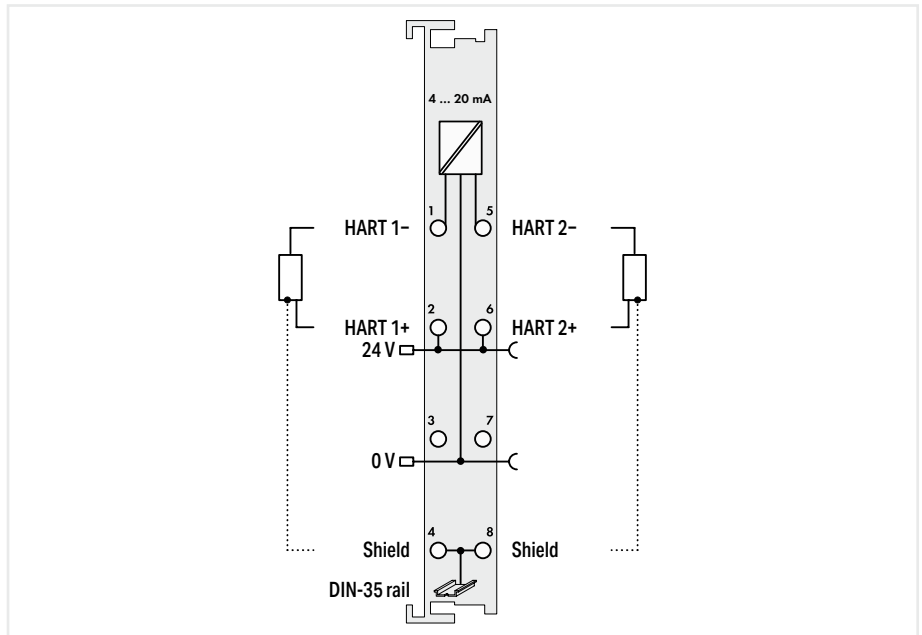

Item description	2-Channel Analog Input; 4 ... 20 mA HART		
Version	Standard	ext. temperature	pluggable (delivery without connector)
Item no.	750-482	750-482/025-000	753-482
Order Text	2AI; 4-20mA HART	2AI; 4-20mA HART; T	2AI; 4-20mA HART

Technical data			
Extended functionality	Overload protection		
Pluggable connector	-		pluggable
Number of analog inputs	2		
Signal type	Current		
Signal type (current)	4 ... 20 mADC		
Signal characteristics	Single-ended		
Sensor connection	2 x (2-wire)		
Resolution [bit]	12 bits		
Conversion time (typ.)	10 ms		
Input voltage (max.)	24 V		
Measurement error (reference temperature)	25 °C		
Measurement error, deviation (max.) from the upper-range value	0.1 %		
Temperature error (max.) of the upper-range value	0.01 %/K		
Supply voltage (field)	24 VDC (-25 ... +30 %); via power jumper contacts (power supply via blade contact; transmission via spring contact)		
Current consumption (5 V system supply)	65 mA		
Data width	2 x 2-byte data; 2 x 2-byte data + 2n x 4-byte data (n = number of dynamic variables); 2 x 2-byte data + 6-byte mailbox		
Configurable functions	4 HART dynamic variables (PV, SV, TV, QV)		
Isolation	500 V system/field		
Ambient temperature (operation)	0 ... +55 °C	-20 ... +60 °C	0 ... +55 °C
Dimensions W x H x D	(12 x 100 x 69.8) mm		
Approvals	CE, IEC, OrdLoc/HazLoc, ATEX/IECEx		
For data sheet and additional information, see:	wago.com/750-482		wago.com/753-482

Accessories	Item no.	Item no.	Item no.
Plug	-	-	753-110

HART devices per channel: 1 device (SingleDrop, no MultiDrop)
 For select fieldbus couplers, FDT/DTM device drivers are available that can be used to integrate the I/O module into a higher-level control system.

Analog input ▶ 4 ... 20 mA ▶ Single-ended



750-482/000-001

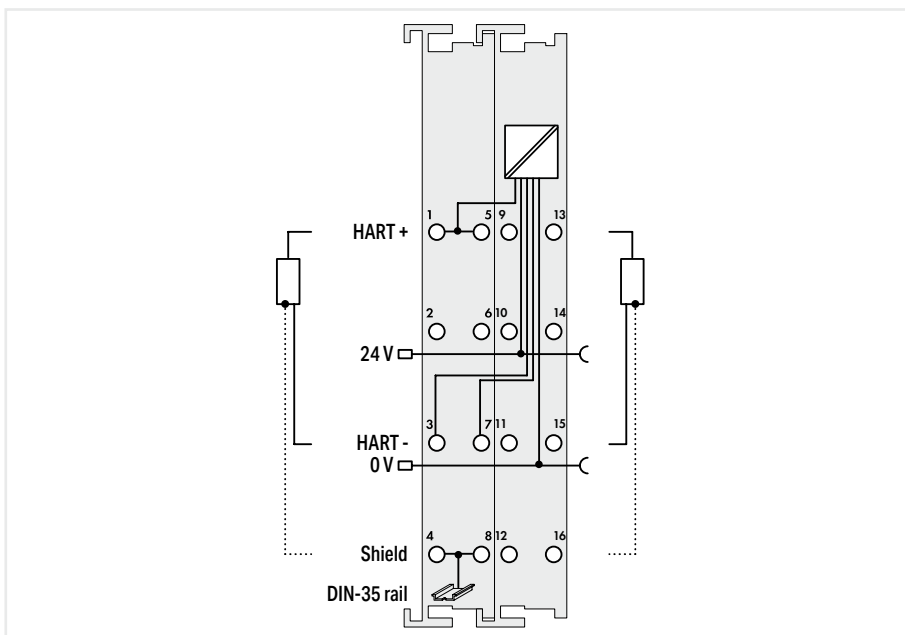

Item description	2-Channel Analog Input; 4 ... 20 mA HART; NAMUR NE 43
Version	NAMUR NE43
Item no.	750-482/000-001
Order Text	2AI; 4-20mA HART; NE43

Technical data	
Extended functionality	Overload protection
Number of analog inputs	2
Signal type	Current
Signal type (current)	3.6 ... 21 mADC
Signal characteristics	Single-ended
Sensor connection	2 x (2-wire)
Resolution [bit]	12 bits
Conversion time (typ.)	315 ms
Input voltage (max.)	24 V
Measurement error (reference temperature)	25 °C
Measurement error, deviation (max.) from the upper-range value	0.2 %
Temperature error (max.) of the upper-range value	0.01 %/K
Supply voltage (field)	24 VDC; via power jumper contacts (power supply via blade contact; transmission via spring contact)
Current consumption (5 V system supply)	25 mA
Data width	2 x 2-byte data; 2 x 2-byte data + 2n x 4-byte data (n = number of dynamic variables); 2 x 2-byte data + 6-byte mailbox
Configurable functions	4 HART dynamic variables (PV, SV, TV, QV)
Isolation	300 VAC system/supply
Ambient temperature (operation)	0 ... +55 °C
Dimensions W x H x D	(24 x 100 x 67.8) mm
Approvals	CE; OrdLoc/HazLoc; ATEX/IECEx
For data sheet and additional information, see:	wago.com/750-482/000-001

HART devices per channel: 1 device (SingleDrop, no MultiDrop)
 For select fieldbus couplers, FDT/DTM device drivers are available that can be used to integrate the I/O module into a higher-level control system.

Analog input ▶ 4 ... 20 mA ▶ Single-ended



750-474

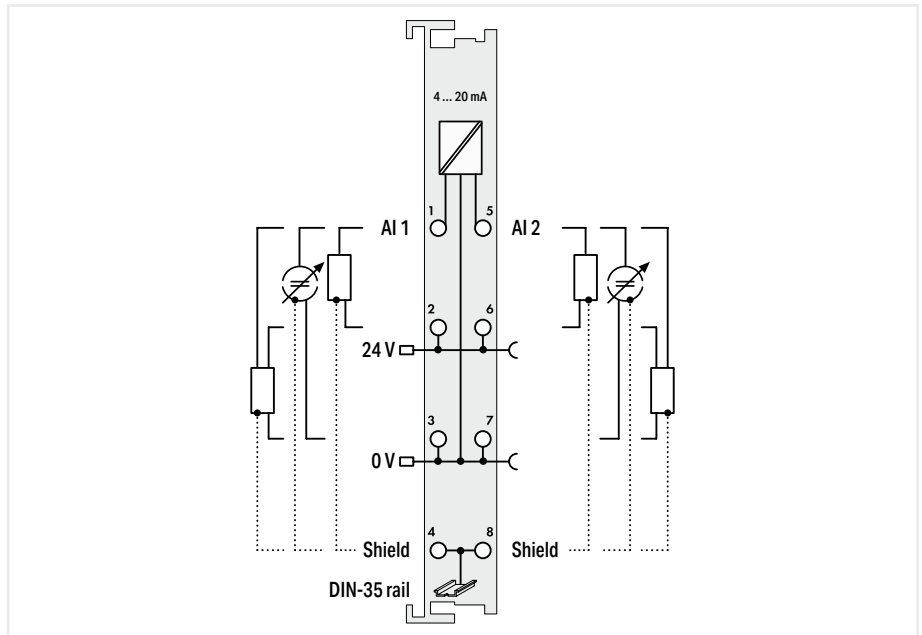

Item description		2-Channel Analog Input; 4 ... 20 mA; Single-ended; 16 bits			
Version	Standard	pluggable (delivery without connector)	Data format (S5 control)	60 Hz	
Item no.	750-474	753-474	750-474/000-200	750-474/005-000	
Order Text	2AI; 4-20mA; SE; 16bits	2AI; 4-20mA; SE; 16bits	2AI; 4-20mA; SE; 16bits; S5	2AI; 4-20mA; SE; 16bits; 60Hz	
Technical data					
Extended functionality	Overload protection				
Pluggable connector	-	pluggable	-		
Customized data format	-		The S5 format allows you to import data with the standard S5 FB 250 function block.		-
Number of analog inputs	2				
Signal type	Current				
Signal type (current)	4 ... 20 mA DC				
Signal characteristics	Single-ended				
Sensor connection	2 x (2-wire, 3-wire)				
Resolution [bit]	15 bits				
Conversion time (typ.)	80 ms				
Input resistance (max.)	220 Ω				
Input voltage (max.)	24 V				
Input filter frequency (analog)	50 Hz		60 Hz		
Measurement error (reference temperature)	25 °C				
Measurement error, deviation (max.) from the upper-range value	0.1 %				
Temperature error (max.) of the upper-range value	0.01 %/K				
Supply voltage (field)	24 VDC (-25 ... +30 %); via power jumper contacts (power supply via blade contact; transmission via spring contact)				
Current consumption (5 V system supply)	75 mA				
Data width	2 x 16-bit data; 2 x 8-bit control/status (optional)				
Isolation	500 V system/field				
Ambient temperature (operation)	0 ... +55 °C				
Dimensions W x H x D	(12 x 100 x 69.8) mm				
Approvals	CE; Marine; OrdLoc/HazLoc; ATEX/IECEx				
For data sheet and additional information, see:	wago.com/750-474	wago.com/753-474	wago.com/750-474/000-200		
Accessories	Item no.	Item no.	Item no.	Item no.	
Plug	-	753-110	-	-	

Analog input ▶ 4 ... 20 mA ▶ Single-ended



750-455/020-000

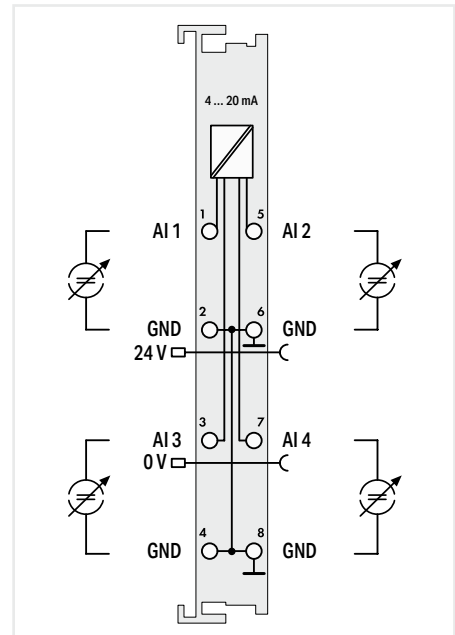
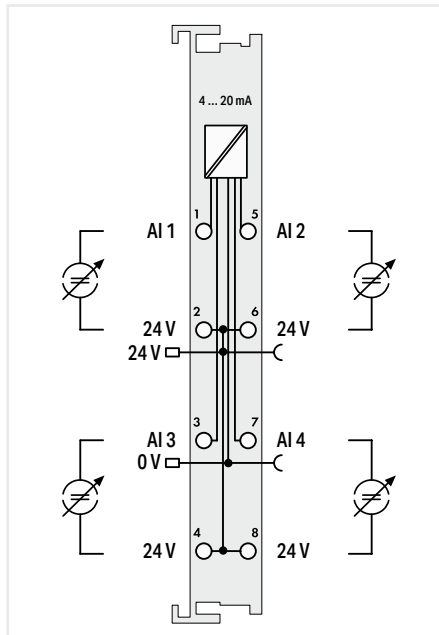

Item description	4-Channel Analog Input; 4 ... 20 mA; Single-ended; 4 x 24 V		4-Channel Analog Input; 4 ... 20 mA; Single-ended; 4 x GND	
Version	4 x 24 V		Standard	
Item no.	750-455/020-000		750-455	
Order Text	4AI; 4-20mA; SE; 4x24V		4AI; 4-20mA; SE	
			ext. temperature	
			750-455/025-000	
			4AI; 4-20mA; SE; T	
Technical data				
Pluggable connector	-			
Number of analog inputs	4			
Signal type	Current			
Signal type (current)	4 ... 20 mADC			
Signal characteristics	Single-ended			
Sensor connection	4 x (2-wire)			
Resolution [bit]	12 bits			
Conversion time (typ.)	10 ms			
Input resistance (max.)	100 Ω			
Input voltage (max.)	32 V			
Measurement error (reference temperature)	25 °C			
Measurement error, deviation (max.) from the upper-range value	0.1 %			
Temperature error (max.) of the upper-range value	0.01 %/K			
Supply voltage (field)	24 VDC (-25 ... +30 %); via power jumper contacts (power supply via blade contact; transmission via spring contact)			
Current consumption (5 V system supply)	65 mA			
Data width	4 x 16-bit data; 4 x 8-bit control/status (optional)			
Isolation	500 V system/field			
Ambient temperature (operation)	0 ... +55 °C			
Dimensions W x H x D	(12 x 100 x 69.8) mm			
Approvals	CE; Marine; OrdLoc/HazLoc; ATEX/IECEx			
For data sheet and additional information, see:	wago.com/750-455/020-000			
Accessories	Item no.		Item no.	
Plug	-		-	

7.4

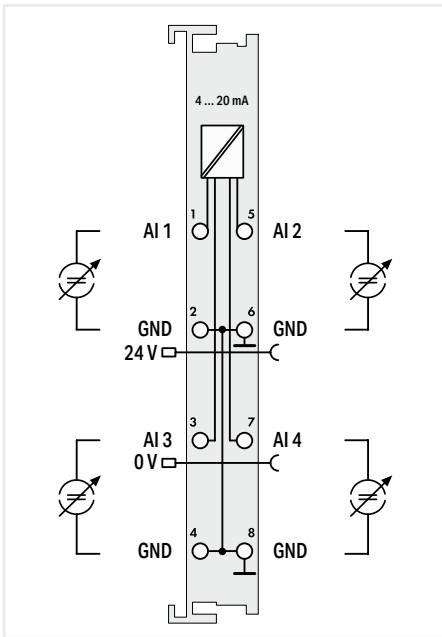

4-Channel Analog Input; 4 ... 20 mA; Single-ended; 4 x GND

pluggable (delivery without connector)

753-455

4AI; 4-20mA; SE

pluggable

4

Current

4 ... 20 mADC

Single-ended

4 x (2-wire)

12 bits

10 ms

100 Ω

32 V

25 °C

0.1 %

0.01 %/K

24 VDC (-25 ... +30 %); via power jumper contacts
(power supply via blade contact; transmission via spring contact)

65 mA

4 x 16-bit data; 4 x 8-bit control/status (optional)

500 V system/field

0 ... +55 °C

(12 x 100 x 69.8) mm

CE; Marine; OrdLoc/HazLoc; ATEX/IECEX

wago.com/753-455

Item no.

753-110

Analog input ► Configurable: current



750-496

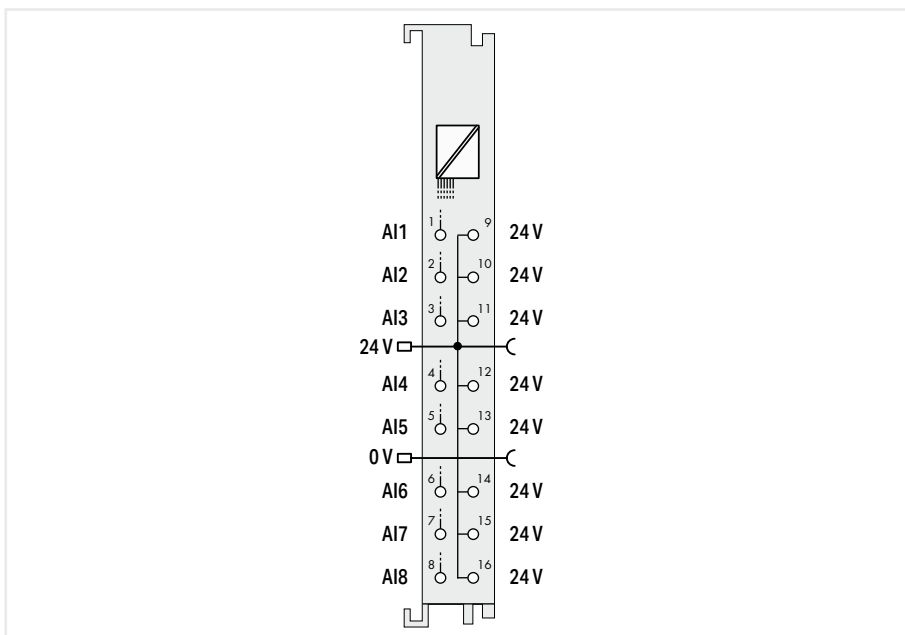

Item description	8-Channel Analog Input; 0/4 ... 20 mA; Single-ended
Version	Standard with 16 connectors
Item no.	750-496
Order Text	8AI; 0/4-20mA; SE

Technical data	
Number of analog inputs	8
Signal type	Current
Signal type (current)	0 ... 20 mADC; 4 ... 20 mADC; 3.6 ... 21 mADC
Sensor connection	8 x (2-wire)
Resolution [bit]	12 bits
Conversion time (typ.)	10 ms
Input resistance (max.)	220 Ω
Input voltage (max.)	31.2 V
Measurement error (reference temperature)	25 °C
Measurement error, deviation (max.) from the upper-range value	0.1 %
Temperature error (max.) of the upper-range value	0.01 %/K
Supply voltage (field)	24 VDC (-25 ... +30 %); via power jumper contacts (power supply via blade contact; transmission via spring contact)
Current consumption (5 V system supply)	69 mA
Data width	8 x 16-bit data; 8 x 8-bit control/status (optional)
Isolation	500 V system/field
Ambient temperature (operation)	0 ... +55 °C
Dimensions W x H x D	(12 x 100 x 69) mm
Approvals	CE; Marine; OrdLoc/HazLoc; ATEX/IECEX

For data sheet and additional information, see:

wago.com/750-496

Analog input ▶ 0 ... 1 A rms (peak value 2.0 A) ▶ Differential



750-475

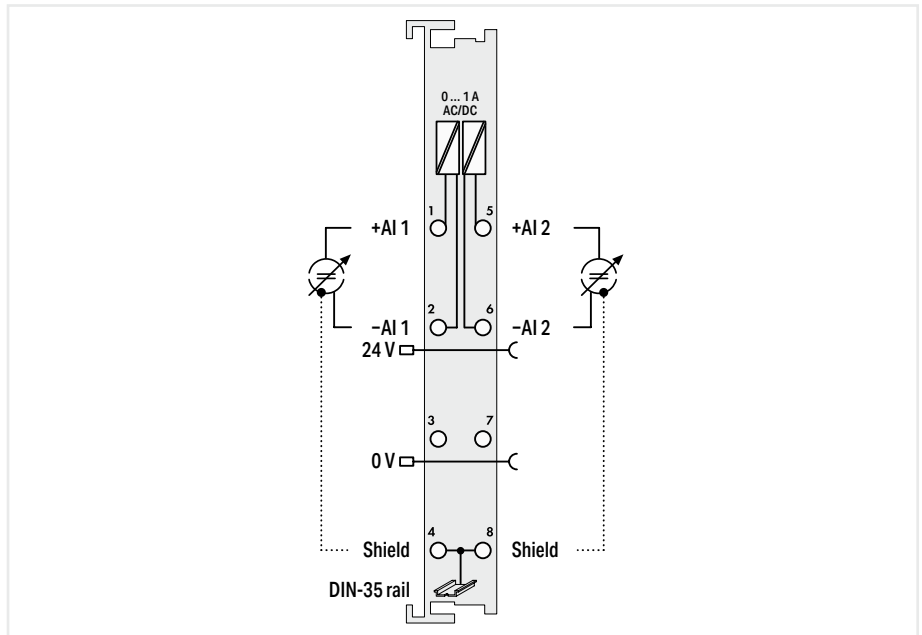

Item description	2-Channel Analog Input; 0 ... 1 VAC/DC; Differential input	
Version	Standard	pluggable (delivery without connector)
Item no.	750-475	753-475
Order Text	2AI; 0-1A AC/DC; Diff	2AI; 0-1A AC/DC; Diff
Technical data		
Pluggable connector	-	pluggable
Number of analog inputs	2	
Signal type	Current	
Signal type (current)	0 ... 1 AAC/DC	
Signal characteristics	Differential	
Sensor connection	2 x (2-wire)	
Resolution [bit]	15 bits	
Conversion time (typ.)	200 ms	
Input resistance (max.)	0.022 Ω	
Input voltage (max.)	24 VAC/DC (-20 ... +20 %)	
Measurement error (reference temperature)	25 °C	
Measurement error, deviation (max.) from the upper-range value	0.1 %	
Temperature coefficient	< ± 110 ppm / K of the full scale value	
Supply voltage (field)	24 VDC (-25 ... +30 %); via power jumper contacts (power supply via blade contact; transmission via spring contact)	
Current consumption (5 V system supply)	80 mA	
Data width	2 x 16-bit data; 2 x 8-bit control/status (optional)	
Isolation	500 V system/field or channel/channel	
Ambient temperature (operation)	0 ... +55 °C	
Dimensions W x H x D	(12 x 100 x 69.8) mm	
Approvals	CE; Marine; OrdLoc/HazLoc; ATEX/IECEx	
For data sheet and additional information, see:	wago.com/750-475	wago.com/753-475
Accessories	Item no.	Item no.
Plug	-	753-110

Analog input ► 0 ... 5 A rms (peak value 6.0 A) ► Differential



750-475/020-000

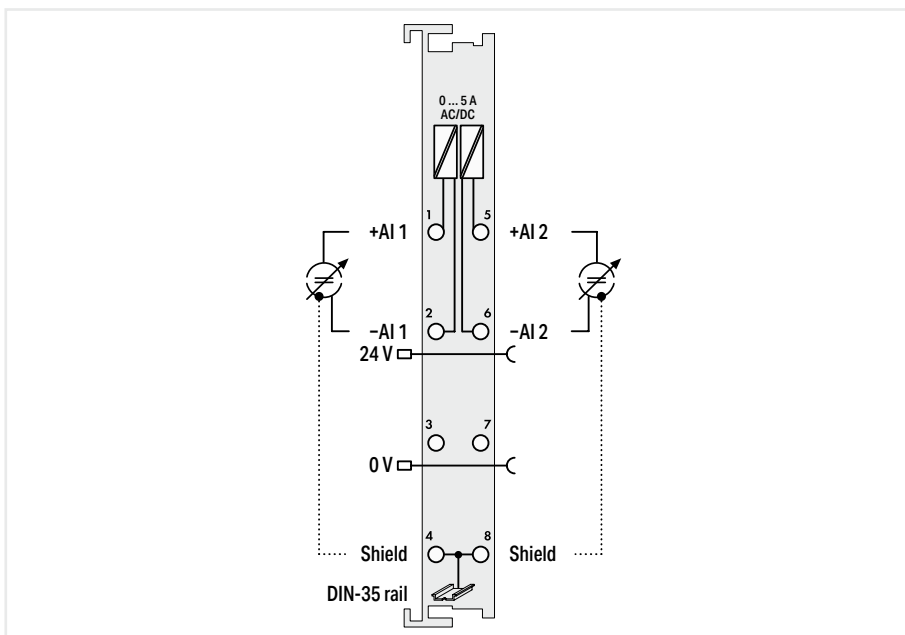

Item description	2-Channel Analog Input; 0 ... 5 VAC/DC; Differential input
Version	0 ... 5 AAC/DC
Item no.	750-475/020-000
Order Text	2AI; 0-5A AC/DC; Diff
Technical data	
Number of analog inputs	2
Signal type	Current
Signal type (current)	0 ... 5 AAC/DC
Signal characteristics	Differential
Sensor connection	2 x (2-wire)
Resolution [bit]	15 bits
Input resistance (max.)	0.022 Ω
Input voltage (max.)	24 VAC/DC (-20 ... +20 %)
Measurement error (reference temperature)	25 °C
Measurement error, deviation (max.) from the upper-range value	0.1 %
Supply voltage (field)	24 VDC (-25 ... +30 %); via power jumper contacts (power supply via blade contact; transmission via spring contact)
Current consumption (5 V system supply)	80 mA
Data width	2 x 16-bit data; 2 x 8-bit control/status (optional)
Isolation	500 V system/field or channel/channel
Ambient temperature (operation)	0 ... +55 °C
Dimensions W x H x D	(12 x 100 x 69.8) mm
Approvals	CE; Marine; OrdLoc/HazLoc; ATEX/IECEX
For data sheet and additional information, see:	wago.com/750-475/020-000

Analog input ▶ ±10 V ▶ Differential



750-456

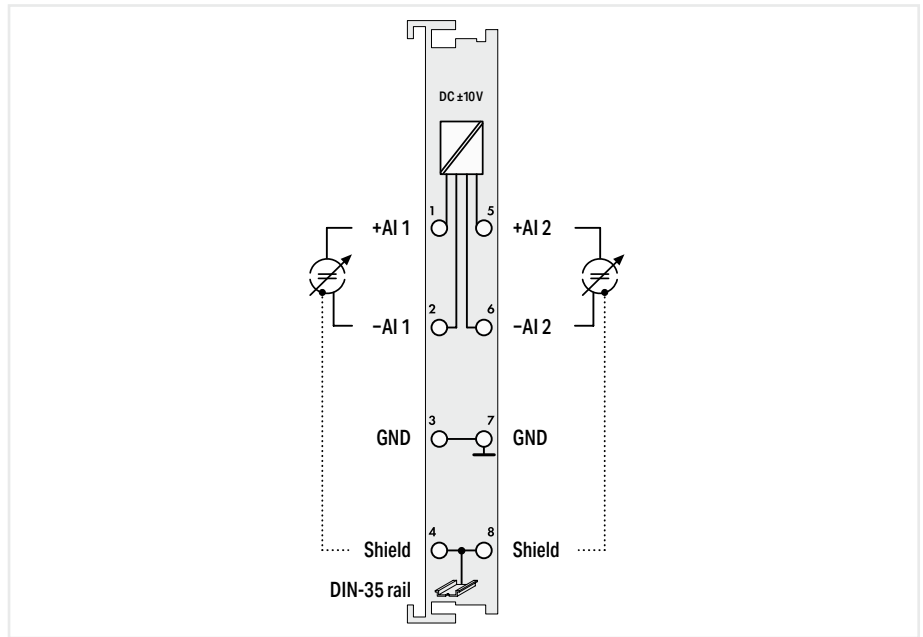

Item description			
Version	2-Channel Analog Input; ±10 VDC; Differential input		
Item no.	750-456	753-456	750-456/000-200
Order Text	2AI; ±10 VDC	2AI; ±10 VDC	2AI; ±10 VDC; S5
Technical data			
Pluggable connector	-	pluggable	-
Customized data format	-	-	The S5 format allows you to import data with the standard S5 FB 250 function block.
Number of analog inputs	2		
Signal type	Voltage		
Signal type (voltage)	-10 ... +10 VDC		
Signal characteristics	Differential		
Sensor connection	2 x (2-wire)		
Resolution [bit]	12 bits		
Conversion time (typ.)	2 ms		
Internal resistance	570 kΩ		
Input voltage (max.)	35 V		
Measurement error (reference temperature)	25 °C		
Measurement error, deviation (max.) from the upper-range value	0.2 %		
Temperature error (max.) of the upper-range value	0.015 %/K		
Current consumption (5 V system supply)	80 mA		
Data width	2 x 16-bit data; 2 x 8-bit control/status (optional)		
Isolation	500 V system/field		
Ambient temperature (operation)	0 ... +55 °C		
Dimensions W x H x D	(12 x 100 x 69.8) mm		
Approvals	CE; Marine; OrdLoc/HazLoc; ATEX/IECEx		
For data sheet and additional information, see:	wago.com/750-456	wago.com/753-456	wago.com/750-456/000-200
Accessories			
Item no.	Item no.	Item no.	Item no.
Plug	-	753-110	-

Analog input ▶ ±10 V ▶ Differential



750-479

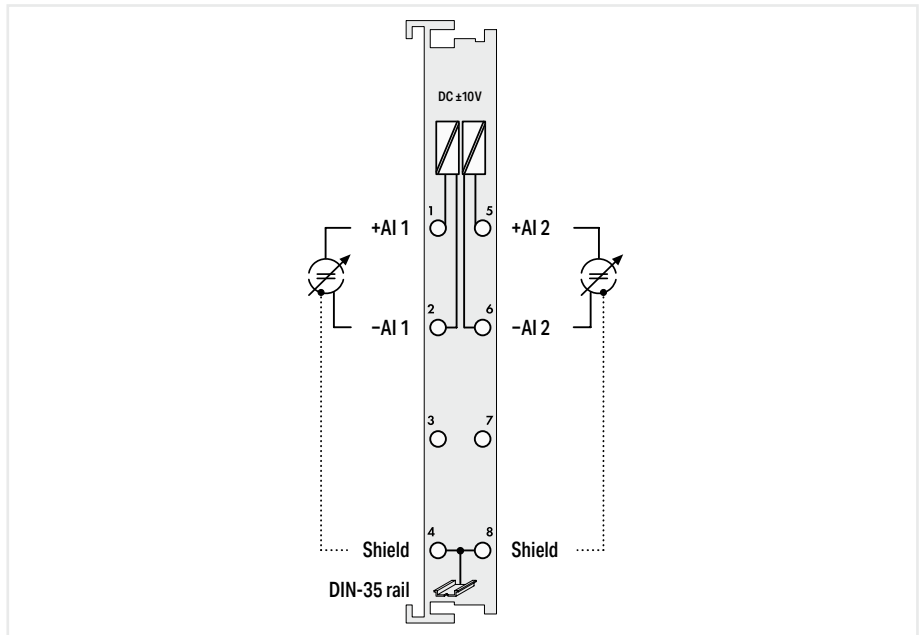

Item description		2-Channel Analog Input; ±10 VDC; Differential input	
Version		Standard	pluggable (delivery without connector)
Item no.	750-479		753-479
Order Text	2AI; ±10 VDC; Diff		2AI; ±10 VDC; Diff
Technical data			
Extended functionality			Time-synchronized measured value acquisition within the module
Pluggable connector	-		pluggable
Number of analog inputs		2	
Signal type		Voltage	
Signal type (voltage)		-10 ... +10 VDC	
Signal characteristics		Differential	
Sensor connection		2 x (2-wire)	
Resolution [bit]		14 bits	
Internal resistance		1000 kΩ	
Admissible continuous overload		60 V	
Measurement error (reference temperature)		25 °C	
Measurement error, deviation (max.) from the upper-range value		0.05 %	
Temperature error (max.) of the upper-range value		0.01 %/K	
Current consumption (5 V system supply)		100 mA	
Data width		2 x 16-bit data; 2 x 8-bit control/status (optional)	
Isolation		500 V system/field or channel/channel	
Ambient temperature (operation)		0 ... +55 °C	
Dimensions W x H x D		(12 x 100 x 69.8) mm	
Approvals		CE; Marine; OrdLoc/HazLoc; ATEX/IECEX	
For data sheet and additional information, see:	wago.com/750-479		wago.com/753-479
Accessories	Item no.		Item no.
Plug	-		753-110

Analog input ▶ ±10 V ▶ Single-ended



750-476

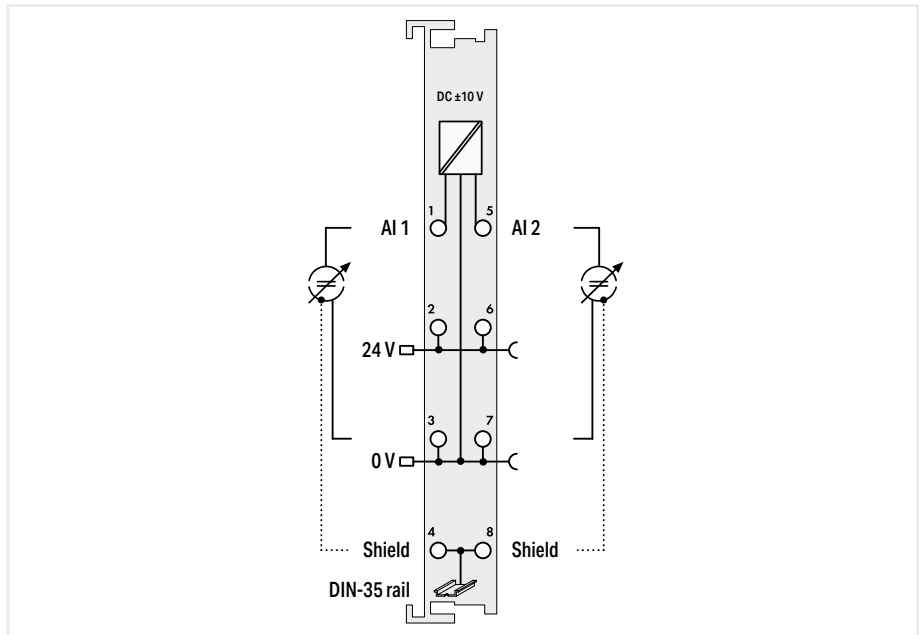

Item description			
Version			
Item no.	750-476	753-476	750-476/000-200
Order Text	2AI; ±10 VDC; SE; 16bits	2AI; ±10 VDC; SE; 16bits	2AI; ±10 VDC; SE; 16bits; S5
Technical data			
Pluggable connector	-	pluggable	-
Customized data format			The S5 format allows you to import data with the standard S5 FB 250 function block.
Number of analog inputs	2		
Signal type	Voltage		
Signal type (voltage)	-10 ... +10 VDC		
Signal characteristics	Single-ended		
Sensor connection	2 x (2-wire)		
Resolution [bit]	16 bits		
Conversion time (typ.)	80 ms		
Internal resistance	130 kΩ		
Input voltage (max.)	24 V		
Input filter frequency (analog)	50 Hz		60 Hz
Measurement error (reference temperature)	25 °C		
Measurement error, deviation (max.) from the upper-range value	0.1 %		
Temperature error (max.) of the upper-range value	0.01 %/K		
Supply voltage (field)	24 VDC (-25 ... +30 %); via power jumper contacts (power supply via blade contact; transmission via spring contact)		
Current consumption (5 V system supply)	75 mA		
Data width	2 x 16-bit data; 2 x 8-bit control/status (optional)		
Isolation	500 V system/field		
Ambient temperature (operation)	0 ... +55 °C		
Dimensions W x H x D	(12 x 100 x 69.8) mm		
Approvals	CE; Marine; OrdLoc/HazLoc; ATEX/IECEx		
For data sheet and additional information, see:	wago.com/750-476	wago.com/753-476	wago.com/750-476/000-200
Accessories	Item no.	Item no.	Item no.
Plug	-	753-110	-

Analog input ▶ ±10 V ▶ Single-ended



750-457

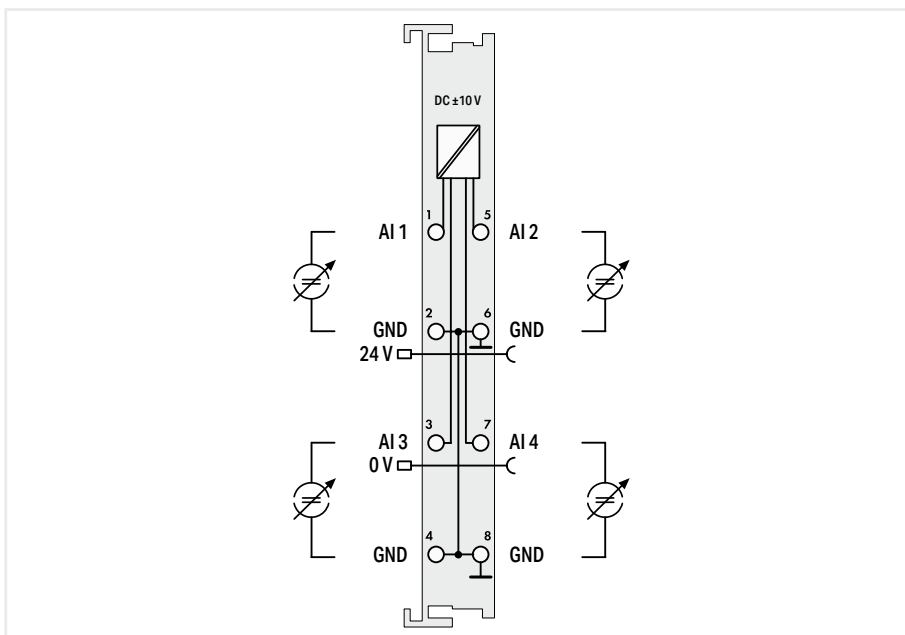

Item description	4-Channel Analog Input; ±10 VDC; Single-ended		
Version	Standard	ext. temperature	pluggable (delivery without connector)
Item no.	750-457	750-457/025-000	753-457
Order Text	4AI; ±10 VDC; SE	4AI; ±10 VDC; SE; T	4AI; ±10 VDC; SE
Technical data			
Pluggable connector	-		pluggable
Number of analog inputs	4		
Signal type	Voltage		
Signal type (voltage)	-10 ... +10 VDC		
Signal characteristics	Single-ended		
Sensor connection	4 x (2-wire)		
Resolution [bit]	12 bits		
Conversion time (typ.)	10 ms		
Internal resistance	100 kΩ		
Input voltage (max.)	±40 V		
Measurement error (reference temperature)	25 °C		
Measurement error, deviation (max.) from the upper-range value	0.1 %		
Temperature error (max.) of the upper-range value	0.01 %/K		
Supply voltage (field)	24 VDC (-25 ... +30 %); via power jumper contacts (power supply via blade contact; transmission via spring contact)		
Current consumption (5 V system supply)	65 mA		
Data width	4 x 16-bit data; 4 x 8-bit control/status (optional)		
Isolation	500 V system/field		
Ambient temperature (operation)	0 ... +55 °C	-20 ... +60 °C	0 ... +55 °C
Dimensions W x H x D	(12 x 100 x 69.8) mm		
Approvals	CE; Marine; OrdLoc/HazLoc; ATEX/IECEX		
For data sheet and additional information, see:	wago.com/750-457		wago.com/753-457
Accessories	Item no.	Item no.	Item no.
Plug	-	-	753-110

Analog input ▶ 0 ... 10 V ▶ Single-ended



750-467

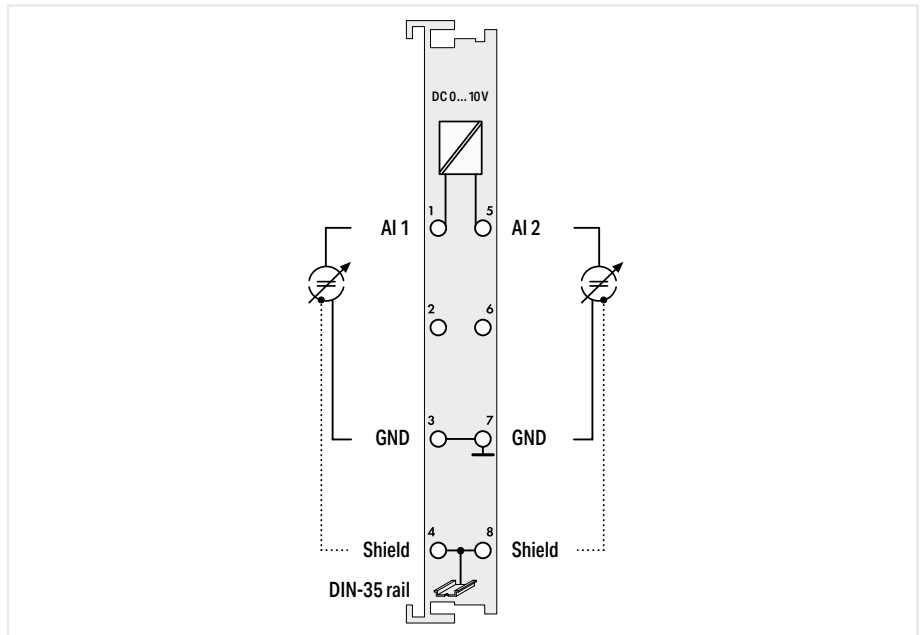

Item description	2-Channel Analog Input; 0 ... 10 VDC; Single-ended	
Version	Standard	pluggable (delivery without connector)
Item no.	750-467	753-467
Order Text	2AI; 0-10 VDC; SE	2AI; 0-10 VDC; SE

Technical data		
Pluggable connector	-	pluggable
Number of analog inputs		2
Signal type		Voltage
Signal type (voltage)		0 ... 10 VDC
Signal characteristics		Single-ended
Sensor connection		2 x (2-wire)
Resolution [bit]		12 bits
Conversion time (typ.)		2 ms
Internal resistance		130 kΩ
Input voltage (max.)		35 V
Measurement error (reference temperature)		25 °C
Measurement error, deviation (max.) from the upper-range value		0.2 %
Temperature error (max.) of the upper-range value		0.01 %/K
Current consumption (5 V system supply)		60 mA
Data width	2 x 16-bit data; 2 x 8-bit control/status (optional)	
Isolation	500 V system/field	
Ambient temperature (operation)	0 ... +55 °C	
Dimensions W x H x D	(12 x 100 x 69.8) mm	
Approvals	CE, OrdLoc/HazLoc, ATEX/IECEx	
For data sheet and additional information, see:	wago.com/750-467	wago.com/753-467

Accessories	Item no.	Item no.
Plug	-	753-110

Analog input ▶ 0 ... 10 V ▶ Single-ended



750-478

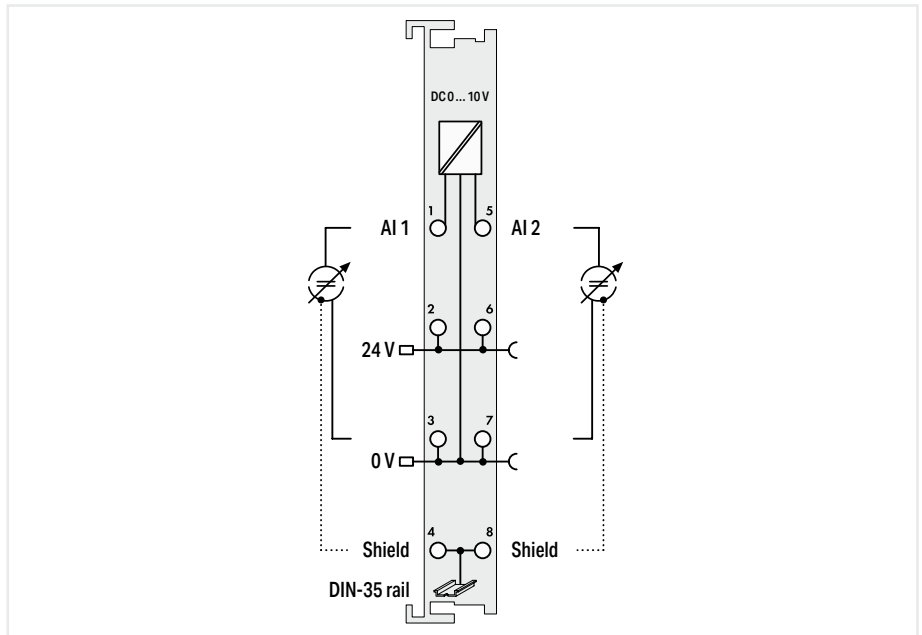

Item description	2-Channel Analog Input; 0 ... 10 VDC; Single-ended; 16 bits		
Version	Standard	pluggable (delivery without connector)	60 Hz
Item no.	750-478	753-478	750-478/005-000
Order Text	2AI; 0-10 VDC; SE; 16bits	2AI; 0-10 VDC; SE; 16bits	2AI; 0-10 VDC; SE; 16bits; 60Hz
Technical data			
Pluggable connector	-	pluggable	-
Number of analog inputs	2		
Signal type	Voltage		
Signal type (voltage)	0 ... 10 VDC		
Signal characteristics	Single-ended		
Sensor connection	2 x (2-wire)		
Resolution [bit]	16 bits		
Conversion time (typ.)	80 ms		
Internal resistance	130 kΩ		
Input voltage (max.)	24 V		
Input filter frequency (analog)	50 Hz	60 Hz	
Measurement error (reference temperature)	25 °C		
Measurement error, deviation (max.) from the upper-range value	0.1 %		
Temperature error (max.) of the upper-range value	0.01 %/K		
Supply voltage (field)	24 VDC (-25 ... +30 %); via power jumper contacts (power supply via blade contact; transmission via spring contact)		
Current consumption (5 V system supply)	75 mA		
Data width	2 x 16-bit data; 2 x 8-bit control/status (optional)		
Isolation	500 V system/field		
Ambient temperature (operation)	0 ... +55 °C		
Dimensions W x H x D	(12 x 100 x 69.8) mm		
Approvals	CE; Marine; OrdLoc/HazLoc; ATEX/IECEx		
For data sheet and additional information, see:	wago.com/750-478	wago.com/753-478	wago.com/750-478/005-000
Accessories	Item no.	Item no.	Item no.
Plug	-	753-110	-

7.4

Analog input ▶ 0 ... 10 V ▶ Single-ended



750-468

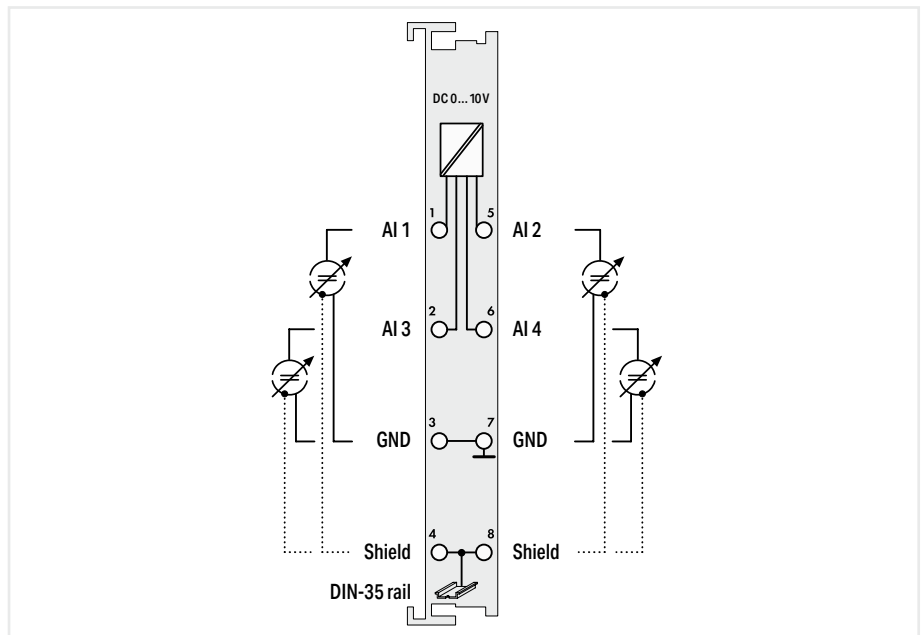

Item description	4-Channel Analog Input; 0 ... 10 VDC; Single-ended	
Version	Standard	ext. temperature
Item no.	750-468	750-468/025-000
Order Text	4AI; 0-10 VDC; SE	4AI; 0-10 VDC; SE; T
Technical data		
Number of analog inputs	4	
Signal type	Voltage	
Signal type (voltage)	0 ... 10 VDC	
Signal characteristics	Single-ended	
Sensor connection	4 x (2-wire)	
Resolution [bit]	12 bits	
Conversion time (typ.)	4 ms	
Internal resistance	133 kΩ	
Input voltage (max.)	35 V	
Measurement error (reference temperature)	25 °C	
Measurement error, deviation (max.) from the upper-range value	0.2 %	
Temperature error (max.) of the upper-range value	0.01 %/K	
Current consumption (5 V system supply)	60 mA	
Data width	4 x 16-bit data; 4 x 8-bit control/status (optional)	
Isolation	500 V system/field	
Ambient temperature (operation)	0 ... +55 °C	-20 ... +60 °C
Dimensions W x H x D	(12 x 100 x 69.8) mm	
Approvals	Marine; OrdLoc/HazLoc; ATEX/IECEX	
For data sheet and additional information, see:	wago.com/750-468	

Analog input ▶ 0 ... 10 V ▶ Single-ended



750-459

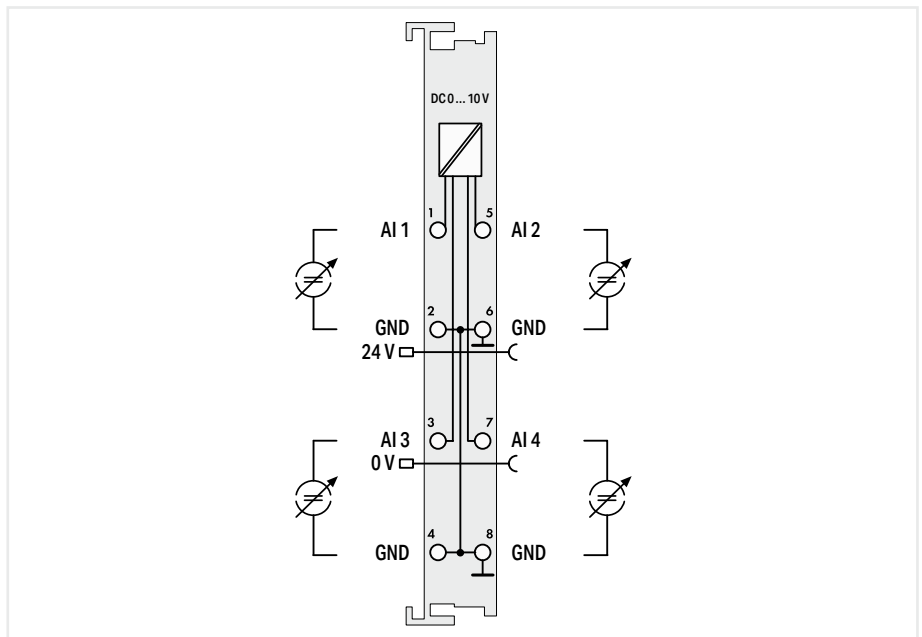

Item description	4-Channel Analog Input; 0 ... 10 VDC; Single-ended	
Version	Standard	pluggable (delivery without connector)
Item no.	750-459	753-459
Order Text	4AI; 0-10 VDC; SE	4AI; 0-10 VDC; SE
Technical data		
Pluggable connector	-	pluggable
Number of analog inputs	4	
Signal type	Voltage	
Signal type (voltage)	0 ... 10 VDC	
Signal characteristics	Single-ended	
Sensor connection	4 x (2-wire)	
Resolution [bit]	12 bits	
Conversion time (typ.)	10 ms	
Internal resistance	100 kΩ	
Input voltage (max.)	±40 V	
Measurement error (reference temperature)	25 °C	
Measurement error, deviation (max.) from the upper-range value	0.1 %	
Temperature error (max.) of the upper-range value	0.01 %/K	
Supply voltage (field)	24 VDC (-25 ... +30 %); via power jumper contacts (power supply via blade contact; transmission via spring contact)	
Current consumption (5 V system supply)	65 mA	
Data width	4 x 16-bit data; 4 x 8-bit control/status (optional)	
Isolation	500 V system/field	
Ambient temperature (operation)	0 ... +55 °C	
Dimensions W x H x D	(12 x 100 x 69.8) mm	
Approvals	CE; Marine; OrdLoc/HazLoc; ATEX/IECEx	
For data sheet and additional information, see:	wago.com/750-459	wago.com/753-459
Accessories	Item no.	Item no.
Plug	-	753-110

7.4

Analog input ► Configurable: voltage



750-497

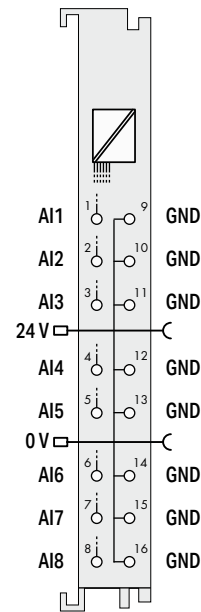

Item description	8-Channel Analog Input; 0 ... 10 VDC/±10 V; Single-ended
Version	Standard with 16 connectors
Item no.	750-497
Order Text	8AI; 0-10 V/±10 VDC; SE
Technical data	
Number of analog inputs	8
Signal type	Voltage
Signal type (voltage)	0 ... 10 VDC; -10 ... +10 VDC
Sensor connection	8 x (2-wire)
Resolution [bit]	12 bits
Internal resistance	100 kΩ
Input voltage (max.)	35 V
Measurement error (reference temperature)	25 °C
Measurement error, deviation (max.) from the upper-range value	0.1 %
Temperature error (max.) of the upper-range value	0.01 %/K
Supply voltage (field)	24 VDC (-25 ... +30 %); via power jumper contacts (power supply via blade contact; transmission via spring contact)
Current consumption (5 V system supply)	105 mA
Data width	8 x 16-bit data; 8 x 8-bit control/status (optional)
Isolation	500 V system/field
Ambient temperature (operation)	0 ... +55 °C
Dimensions W x H x D	(12 x 100 x 69) mm
Approvals	CE; Marine; OrdLoc/HazLoc; ATEX/IECEX
For data sheet and additional information, see:	wago.com/750-497

Analog input ► 0 ... 10 V rms (peak value 20 V) ► Differential



750-477

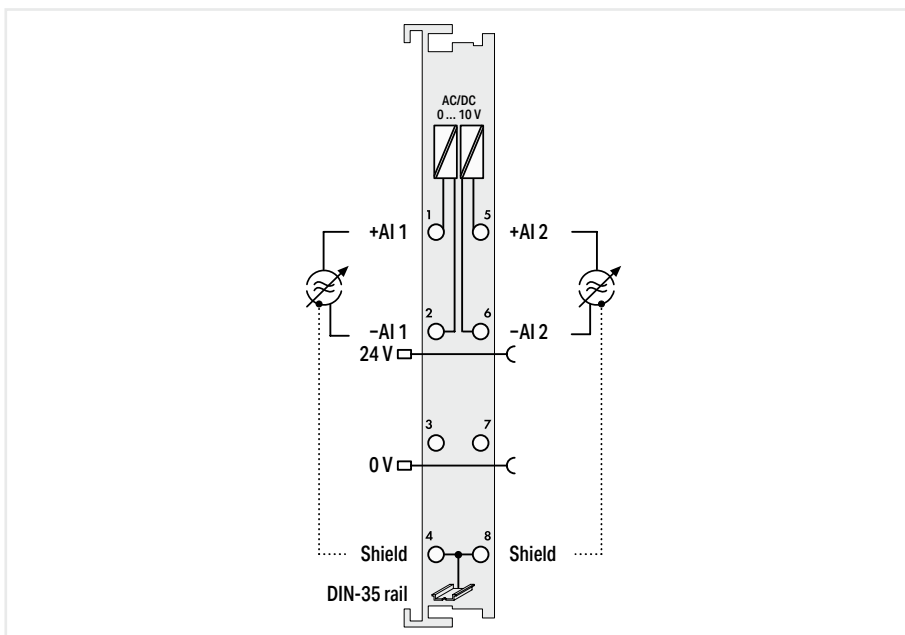

Item description	2-Channel Analog Input; 0 ... 10 VAC/DC; Differential input	
Version	Standard	pluggable (delivery without connector)
Item no.	750-477	753-477
Order Text	2AI; 0-10 VDC; Diff	2AI; 0-10 VAC/VDC; Diff
Technical data		
Pluggable connector	-	pluggable
Number of analog inputs	2	
Signal type	Voltage	
Signal type (voltage)	0 ... 10 VAC/DC	
Signal characteristics	Differential	
Sensor connection	2 x (2-wire)	
Resolution [bit]	15 bits	
Conversion time (typ.)	200 ms	
Internal resistance	120 kΩ	
Measurement error (reference temperature)	25 °C	
Measurement error, deviation (max.) from the upper-range value	0.1 %	
Temperature coefficient	< ±110 ppm/K of greatest measurement range	
Supply voltage (field)	24 VDC (-25 ... +30 %); via power jumper contacts (power supply via blade contact; transmission via spring contact)	
Current consumption (5 V system supply)	80 mA	
Data width	2 x 16-bit data; 2 x 8-bit control/status (optional)	
Isolation	500 V system/field or channel/channel	
Ambient temperature (operation)	0 ... +55 °C	
Dimensions W x H x D	(12 x 100 x 69.8) mm	
Approvals	CE; OrdLoc/HazLoc; ATEX/IECEx	
For data sheet and additional information, see:	wago.com/750-477	wago.com/753-477
Accessories	Item no.	Item no.
Plug	-	753-110

Analog input ▶ 0 ... 30 V ▶ Differential



750-483

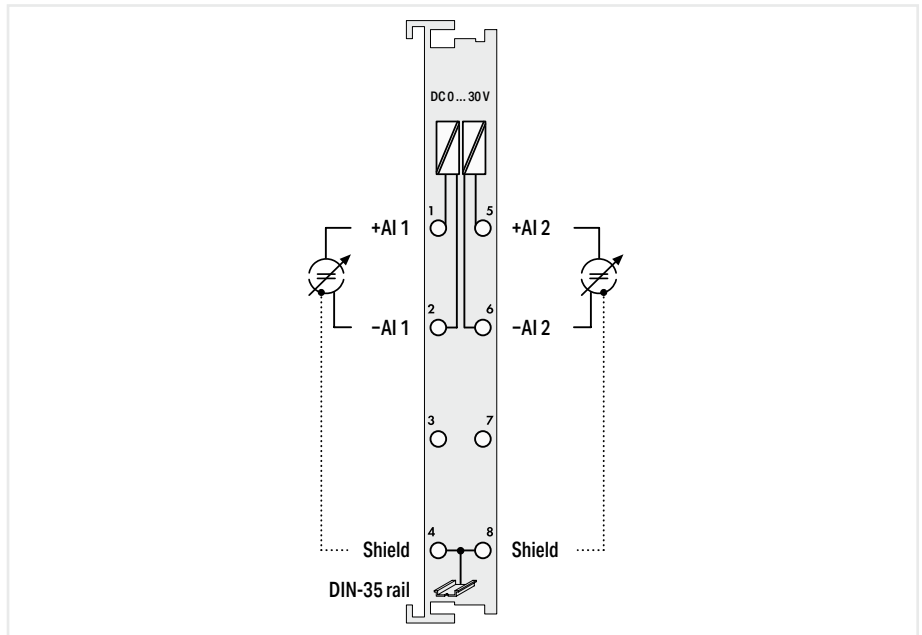

Item description	2-Channel Analog Input; 0 ... 30 VDC; Differential input	
Version	Standard	pluggable (delivery without connector)
Item no.	750-483	753-483
Order Text	2AI; 0-30 VDC; Diff	2AI; 0-30 VDC; Diff

Technical data		
Extended functionality	Time-synchronized measured value acquisition within the module	
Pluggable connector	-	pluggable
Number of analog inputs	2	
Signal type	Voltage	
Signal type (voltage)	0 ... 30 VDC	
Signal characteristics	Differential	
Sensor connection	2 x (2-wire)	
Resolution [bit]	14 bits	
Internal resistance	1000 kΩ	
Admissible continuous overload	60 V	
Measurement error (reference temperature)	25 °C	
Measurement error, deviation (max.) from the upper-range value	0.05 %	
Temperature error (max.) of the upper-range value	0.01 %/K	
Current consumption (5 V system supply)	80 mA	
Data width	2 x 16-bit data; 2 x 8-bit control/status (optional)	
Isolation	500 V system/field or channel/channel	
Ambient temperature (operation)	0 ... +55 °C	
Dimensions W x H x D	(12 x 100 x 69.8) mm	
Approvals	CE; Marine; OrdLoc/HazLoc; ATEX/IECEx	
For data sheet and additional information, see:	wago.com/750-483	wago.com/753-483

Accessories	Item no.	Item no.
Plug	-	753-110

Analog input ► Voltages and currents (configurable channel for channel) ► Differential



750-471

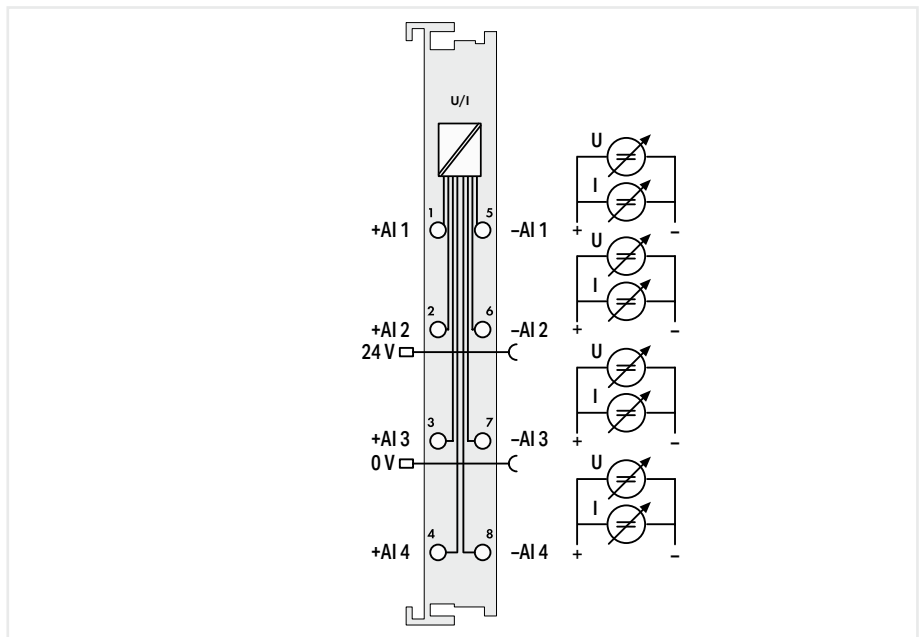

Item description	4-Channel Analog Input; for voltage/current
Version	Standard
Item no.	750-471
Order Text	4AI; U/I; Diff; 16bits; Diagn
Technical data	
Number of analog inputs	4
Signal type	Voltage; Current
Signal type (current)	0 ... 20 mADC; 4 ... 20 mADC; 3.6 ... 21 mADC; -20 ... +20 mADC
Signal type (voltage)	0 ... 10 VDC; -10 ... +10 VDC; -0.2 ... +0.2 VDC
Signal characteristics	Differential
Sensor connection	4 x (2-wire)
Resolution [bit]	16 bits
Conversion time (typ.)	10 ms
Input resistance (max.)	120 Ω
Internal resistance	100 kΩ
Input voltage (max.)	31.2 VDC
Reference for measurement error	Input ranges
Measurement error (reference temperature)	25 °C
Measurement error, deviation (max.) from the upper-range value	0.1 %
Reference for measurement error (2)	±200 mV
Measurement error, reference temperature (2)	25 °C
Measurement error, deviation (max.) of the upper-range value (2)	0.3 %
Temperature error (max.) of the upper-range value	0.01 %/K
Supply voltage (field)	24 VDC; via power jumper contacts (power supply via blade contact; transmission via spring contact)
Current consumption (5 V system supply)	100 mA
Data width	4 x 16-bit data; 4 x 8-bit control/status (optional)
Isolation	Functional insulation: 2000 VDC system/channel; 2000 VDC channel/channel
Ambient temperature (operation)	0 ... +55 °C
Dimensions W x H x D	(12 x 100 x 69.8) mm
Approvals	CE; Marine; OrdLoc/HazLoc; ATEX/IECEX
For data sheet and additional information, see:	wago.com/750-471

Analog input ▶ Resistance sensors



750-461/020-000

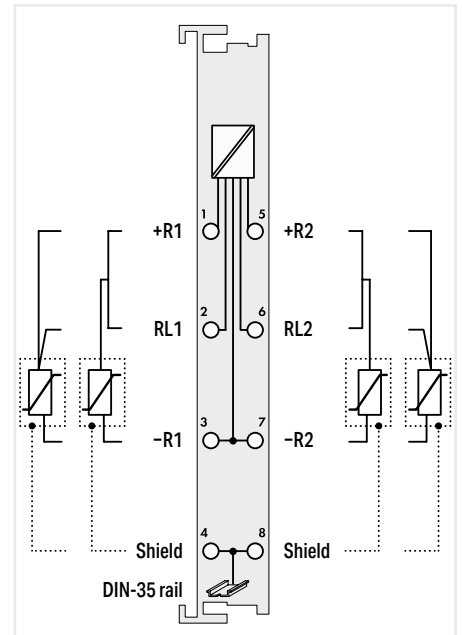
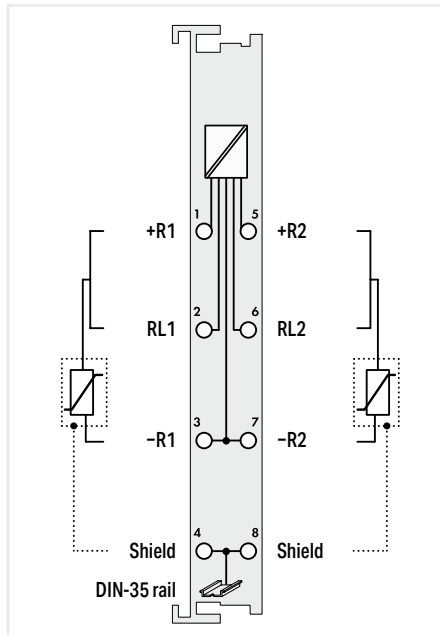

Item description
Version
Item no.
Order Text

2-Channel Analog Input; for resistance sensors
NTC 20k
750-461/020-000
2AI; NTC 20k

2-Channel Analog Input; Resistance measurement
10 ... 1200 Ohm
750-461/000-002
2AI; 10R-1k2
10 ... 5000 Ohm
750-461/000-007
2AI; 10R-5k0

Technical data
Number of analog inputs
Signal type
Sensor types
Sensor connection
Temperature range
Resolution (over entire range)
Conversion time (typ.)
Measuring current (typ.)
Measurement error (25 °C)
Measurement error (reference temperature)
Measurement error, deviation (max.) from the upper-range value
Temperature error (max.) of the upper-range value
Current consumption (5 V system supply)
Data width
Isolation
Ambient temperature (operation)
Dimensions W x H x D
Approvals

2
Resistance measurement
NTC 20 kOhm
2 x (2-wire)
-30 ... +130 °C
0.1 °C
320 ms
0.05 mA
0.5 ... 3.0 K (temperature-dependent)
-
-
0.002 %/K
65 mA
2 x 16-bit data; 2 x 8-bit control/status (optional)
500 V system/field
0 ... +55 °C
(12 x 100 x 69.8) mm
CE; Marine; OrdLoc/HazLoc; ATEX/IECEX

2
Potentiometer positions
10R ... 1k2
10R ... 5k0
2 x (2-wire)
-
0.1 Ohm
0.5 Ohm
320 ms
0.5 mA
-
25 °C
0.2 %
0.01 %/K
80 mA
2 x 16-bit data; 2 x 8-bit control/status (optional)
500 V system/field
0 ... +55 °C
(12 x 100 x 69.8) mm
CE; Marine; OrdLoc/HazLoc; ATEX/IECEX

For data sheet and additional information, see:

wago.com/750-461/020-000

wago.com/750-461/020-000

Analog input ► Resistance sensors



750-461/000-003

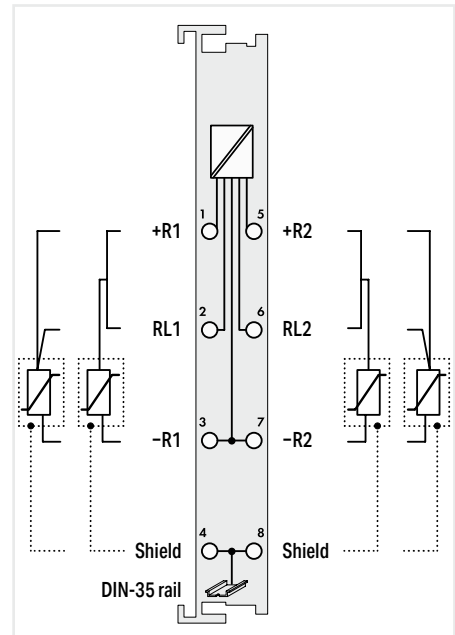
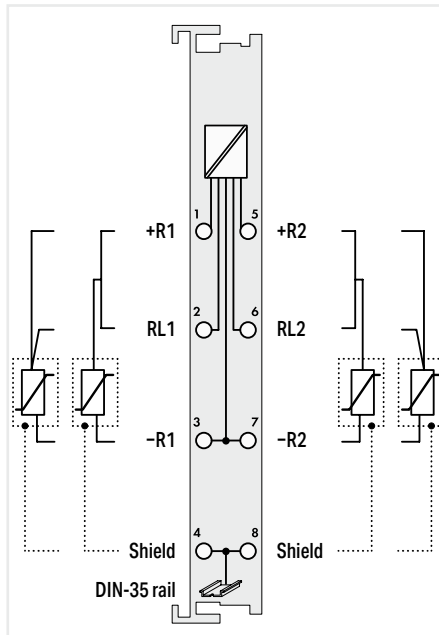

Item description	2-Channel Analog Input; for resistance sensors		2-Channel Analog Input; for Pt100/RTD resistance sensors	
Version	Pt1000/RTD	Ni1000/RTD	Standard	ext. temperature
Item no.	750-461/000-003	750-461/000-005	750-461	750-461/025-000
Order Text	2AI; Pt1000/RTD	2AI; Ni1000/RTD	2AI; Pt100/RTD	2AI; Pt100/RTD; Adjust; T
Technical data				
Pluggable connector	-		-	
Customized data format	-		-	
Number of analog inputs	2		2	
Signal type	Resistance measurement		Resistance measurement	
Sensor types	Pt1000	Ni1000 TK6180	Pt100	
Sensor connection	2 x (2-wire, 3-wire)		2 x (2-wire, 3-wire)	
Temperature range	-200 ... +850 °C	-60 ... +250 °C	-200 ... +850 °C	
Resolution (over entire range)	0.1 °C		0.1 °C	
Conversion time (typ.)	320 ms		320 ms	
Measuring current (typ.)	0.5 mA		0.5 mA	
Measurement error (reference temperature)	25 °C		25 °C	
Measurement error, deviation (max.) from the upper-range value	0.2 %		0.2 %	
Temperature error (max.) of the upper-range value	0.01 %/K		0.01 %/K	
Current consumption (5 V system supply)	80 mA		80 mA	
Data width	2 x 16-bit data; 2 x 8-bit control/status (optional)		2 x 16-bit data; 2 x 8-bit control/status (optional)	
Isolation	500 V system/field		500 V system/field	
Ambient temperature (operation)	0 ... +55 °C		0 ... +55 °C	-20 ... +60 °C
Dimensions W x H x D	(12 x 100 x 69.8) mm		(12 x 100 x 69.8) mm	
Approvals	CE, Marine, OrdLoc/HazLoc, ATEX/IECEx		CE, Marine, OrdLoc/HazLoc, ATEX/IECEx	
For data sheet and additional information, see:	wago.com/750-461/000-003		wago.com/750-461/000-003	
Accessories	Item no.	Item no.	Item no.	Item no.
Plug	-	-	-	-

7.4

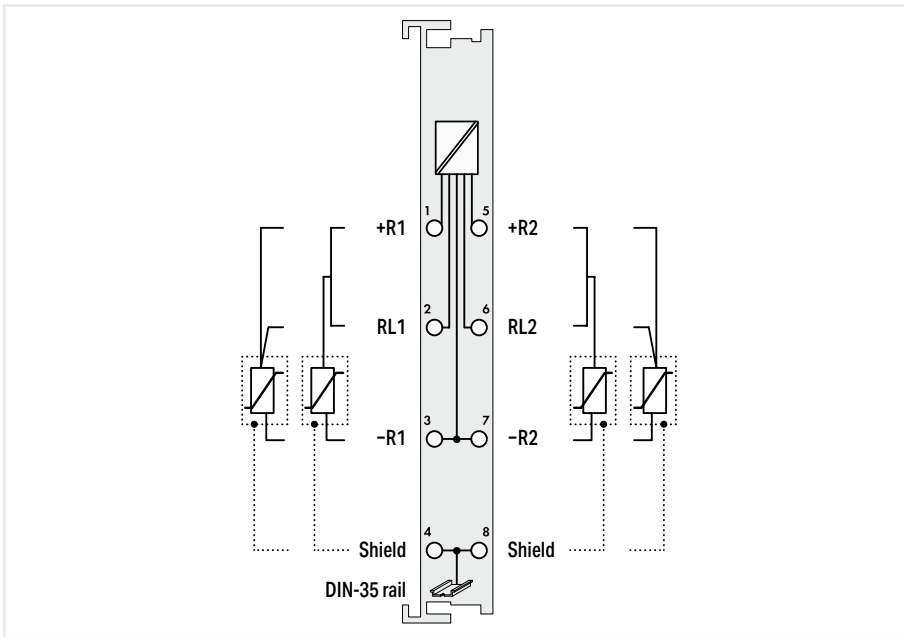

2-Channel Analog Input; for Pt100/RTD resistance sensors

pluggable (delivery without connector)	Data format (S5 control)	adjustable	pluggable (delivery without connector); adjustable
753-461	750-461/000-200	750-461/003-000	753-461/003-000
2AI; Pt100/RTD	2AI; Pt100/RTD; S5	2AI; Pt100/RTD; Adjust	2AI; Pt100/RTD; Adjust

pluggable	-	pluggable
-	The S5 format allows you to import data with the standard S5 FB 250 function block.	-

2

Resistance measurement	
Pt100	Pt100; Configurable: Pt, Ni, Ohm
2 x (2-wire, 3-wire)	
-200 ... +850 °C	-200 °C ... +850 °C (Pt), -60 °C ... +250 °C (Ni)
0.1 °C	
320 ms	
0.5 mA	
25 °C	
0.2 %	
0.01 %/K	
80 mA	
2 x 16-bit data; 2 x 8-bit control/status (optional)	
500 V system/field	
0 ... +55 °C	
(12 x 100 x 69.8) mm	

CE, Marine, OrdLoc/HazLoc, ATEX/IECEx

wago.com/753-461	wago.com/750-461/000-200	wago.com/753-461/003-000
------------------	--------------------------	--------------------------

Item no.	Item no.	Item no.	Item no.
753-110	-	-	753-110

Analog input ► Resistance sensors



750-464/020-000

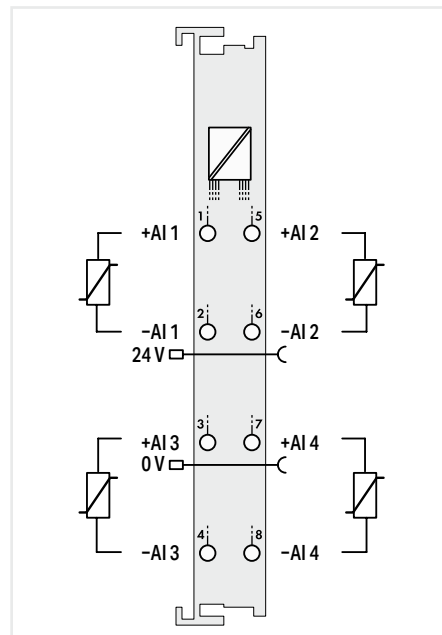
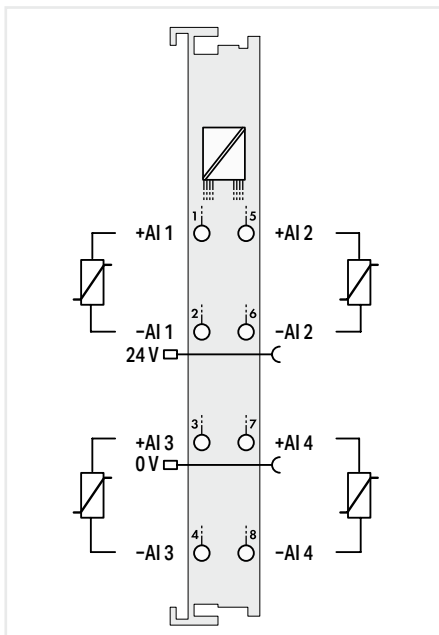

Item description	4-Channel Analog Input; for NTC resistance sensors; Adjustable	4-Channel Analog Input; Resistance measurement
Version	NTC	Measurement range: -30 °C ... +150 °C
Item no.	750-464/020-000	750-463
Order Text	4AI; NTC; Adjust	4AI; RTD; -30°C...+150°C
Technical data		
Number of analog inputs	4	4
Signal type	Resistance measurement	Resistance measurement
Sensor types	NTC 10 kOhm; Configurable: NTC 10 kOhm Thermokon, NTC 20 kOhm, NTC 20 kOhm Thermokon	Pt1000; Configurable: Ni1000, KTY 81
Sensor connection	4 x (2-wire)	4 x (2-wire)
Temperature range	-30 ... +150 °C	-30 ... +150 °C
Resolution (over entire range)	0.1 °C	0.1 °C
Conversion time (typ.)	320 ms	-
Measuring current (typ.)	≤ 350 µA	≤ 350 µA
Measurement error (25 °C)	≤ 2 K within the entire temperature range	≤ 0.5 K in temperature range: -30 ... +150 °C
Temperature coefficient	≤ 20 ppm/K	≤ 20 ppm/K
Supply voltage (field)	24 VDC (-25 ... +30 %); via power jumper contacts (power supply via blade contact; transmission via spring contact)	24 VDC (-25 ... +30 %); via power jumper contacts (power supply via blade contact; transmission via spring contact)
Current consumption (5 V system supply)	50 mA	50 mA
Data width	4 (2) x 16-bit data; 4 (2) x 8-bit control/status (optional)	4 x 16-bit data; 4 x 8-bit control/status (optional)
Isolation	500 V system/field	500 V system/field
Ambient temperature (operation)	0 ... +55 °C	0 ... +55 °C
Dimensions W x H x D	(12 x 100 x 67.8) mm	(12 x 100 x 67.8) mm
Approvals	CE, Marine, OrdLoc/HazLoc, ATEX/IECEx	CE, OrdLoc, ATEX/IECEx
For data sheet and additional information, see:	wago.com/750-464/020-000	wago.com/750-463

Analog input ▶ Resistance sensors



750-464

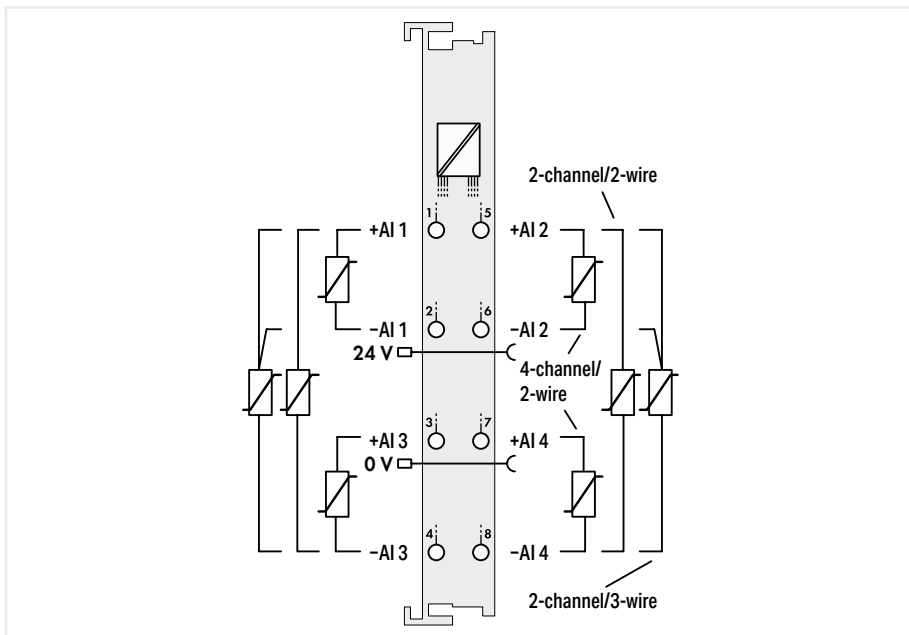

Item description	2/4-Channel Analog Input; Resistance measurement; Adjustable
Version	Standard
Item no.	750-464
Order Text	2/4AI; RTD; Adjust
Technical data	
Number of analog inputs	4
Signal type	Resistance measurement; Potentiometer positions
Sensor types	Pt100; Configurable: Pt200, Pt500, Pt1000, Ni100, Ni120, Ni1000; Potentiometer (2-channel operation only): 10R ... 1k Ω , 10R ... 5k Ω
Sensor connection	4 x (2-wire); 2 x (3-wire)
Temperature range	-200 ... +850 °C (Pt100), -60 ... +300 °C (Ni 100, Ni 1000), -60 ... +250 °C (Ni 1000 TK5000), -80 ... +260 °C (Ni 120)
Resolution (over entire range)	0.1 °C
Conversion time (typ.)	320 ms
Measuring current (typ.)	$\leq 350 \mu\text{A}$
Measurement error (25 °C)	$\leq 1 \text{ K}$ within the entire temperature range, $\leq 0.5 \text{ K}$ within the temperature range (-30 ... +120 °C, Pt 1000)
Temperature coefficient	$\leq 20 \text{ ppm/K}$
Supply voltage (field)	24 VDC (-25 ... +30 %); via power jumper contacts (power supply via blade contact; transmission via spring contact)
Current consumption (5 V system supply)	50 mA
Data width	4 (2) x 16-bit data; 4 (2) x 8-bit control/status (optional)
Isolation	500 V system/field
Ambient temperature (operation)	0 ... +55 °C
Dimensions W x H x D	(12 x 100 x 67.8) mm
Approvals	CE; Marine; OrdLoc/HazLoc; ATEX/IECEX
For data sheet and additional information, see:	wago.com/750-464

Analog input ► Resistance sensors



750-450

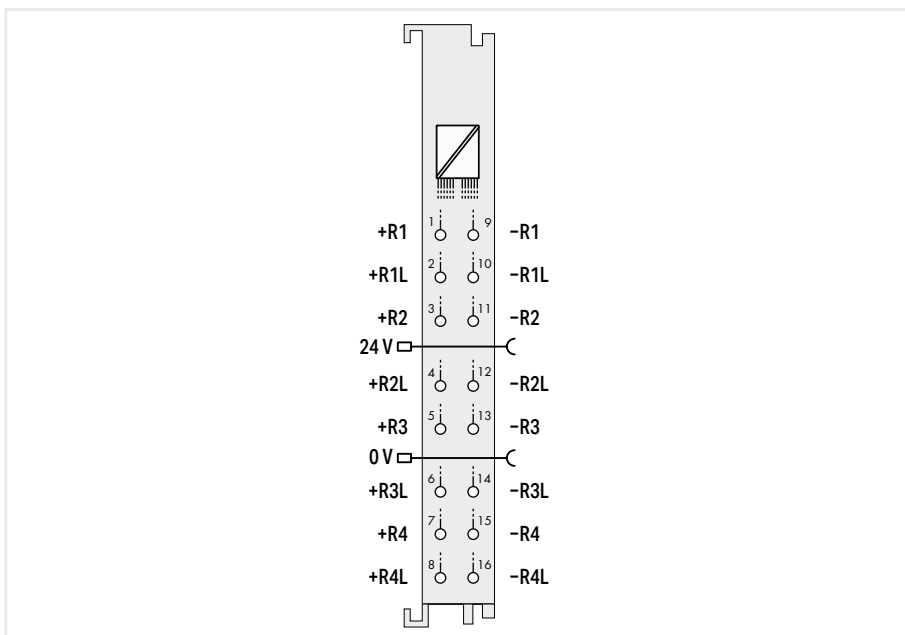

Item description	4-Channel Analog Input; Resistance measurement; Adjustable
Version	Standard with 16 connectors
Item no.	750-450
Order Text	4AI; RTD; Adjust
Technical data	
Number of analog inputs	4
Signal type	Resistance measurement; Potentiometer positions
Sensor types	Pt100; Configurable: Pt200, Pt500, Pt1000, Ni100, Ni120, Ni1000 (TK6180 + TK5000), Potentiometer: 10R ... 1k2, 10R ... 5k0
Sensor connection	4 x (2-wire, 3-wire, 4-wire)
Temperature range	-200 ... +850 °C (Pt100, Pt200, Pt500, Pt1000), -60 ... +250 °C (Ni100, Ni1000), -80 ... +260 °C (Ni120)
Resolution (over entire range)	0.1 °C (over the entire range); 0.01 °C (-50 ... 150 °C; Pt1000, Ni1000)
Conversion time (typ.)	100 ms
Measuring current (typ.)	≤ 350 µA
Measurement error (25 °C)	≤ ±0.6 K (Pt100, Pt200, Pt500, Ni100, Ni120); ≤ ±0.2 K (Pt1000, Ni1000); ±0.3 ... 0.7 Ω for resistance measurement
Supply voltage (field)	24 VDC (-25 ... +30 %); via power jumper contacts (power supply via blade contact; transmission via spring contact)
Current consumption (5 V system supply)	85 mA
Data width	4 x 16-bit data; 4 x 8-bit control/status (optional)
Isolation	500 V system/field
Ambient temperature (operation)	0 ... +55 °C
Dimensions W x H x D	(12 x 100 x 69) mm
Approvals	CE; Marine; OrdLoc/HazLoc; ATEX/IECEx

For data sheet and additional information, see:

wago.com/750-450

Analog input ► Resistance sensors



750-451

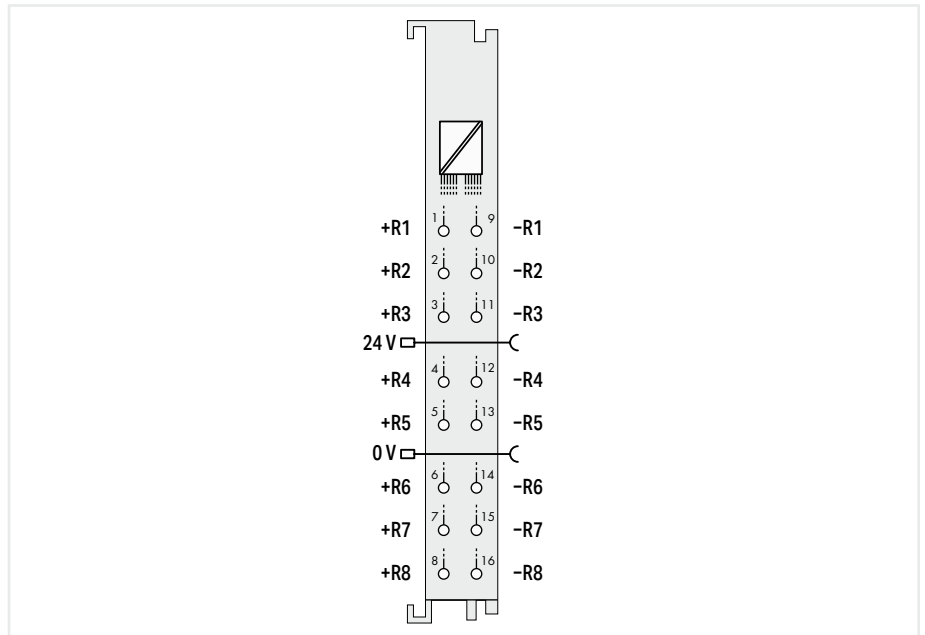

Item description		8-Channel Analog Input; Resistance measurement; Adjustable	
Version		ext. temperature	Standard with 16 connectors
Item no.	750-451/025-000		750-451
Order Text	8AI; RTD; Adjust; T		8AI; RTD; Adjust
Technical data			
Number of analog inputs	8		
Signal type	Resistance measurement; Potentiometer positions		
Sensor types	Pt100; Configurable: Pt200, Pt500, Pt1000, Ni100, Ni120, Ni1000 (TK6180 + TK5000), Potentiometer: 10R ... 1k2, 10R ... 5k0		
Sensor connection	8 x (2-wire)		
Temperature range	-200 ... +850 °C (Pt100, Pt200, Pt500, Pt1000), -60 ... +250 °C (Ni100, Ni1000), -80 ... +260 °C (Ni120)		
Resolution (over entire range)	0.1 °C (over the entire range); 0.01 °C (-50 ... 150 °C; Pt1000, Ni1000)		
Conversion time (typ.)	100 ms		
Measuring current (typ.)	≤ 350 µA		
Measurement error (25 °C)	≤ ±0.6 K (Pt100, Pt200, Pt500, Ni100, Ni120); ≤ ±0.2 K (Pt1000, Ni1000); ≤ ±0.3 Ω for resistance measurement		
Supply voltage (field)	24 VDC (-25 ... +30 %); via power jumper contacts (power supply via blade contact; transmission via spring contact)		
Current consumption (5 V system supply)	110 mA		
Data width	8 x 16-bit data; 8 x 8-bit control/status (optional)		
Isolation	500 V system/field		
Ambient temperature (operation)	-20 ... +60 °C		0 ... +55 °C
Dimensions W x H x D	(12 x 100 x 69) mm		
Approvals			

For data sheet and additional information, see:

wago.com/750-451/025-000

Analog input ▶ Thermocouples



750-469

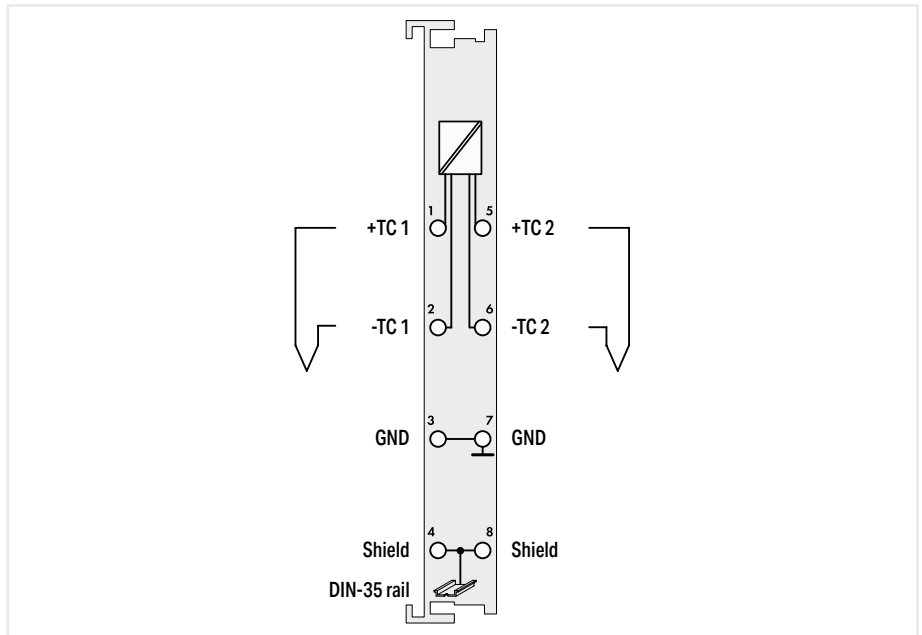

Item description	2-Channel Analog Input; Thermocouple K; Diagnostics				
Version	Standard	pluggable (delivery without connector)	Data format (S5 control)	adjustable	pluggable (delivery without connector); adjustable
Item no.	750-469	753-469	750-469/000-200	750-469/003-000	753-469/003-000
Order Text	2AI; TC K; Diagn	2AI; TC K; Diagn	2AI; TC K; Diagn; S5	2AI; TC K; Diagn Adjust	2AI; TC K; Diagn Adjust

Technical data					
Pluggable connector	-	pluggable	-	-	pluggable
Customized data format	-	-	The S5 format allows you to import data with the standard S5 FB 250 function block.	-	-
Number of analog inputs	2				
Signal type	Thermocouple		Thermocouple; Low voltages		
Sensor types	Thermocouple K		Thermocouple K; Configurable: L, J, E, T, N, U, B, R, S, mV		
Sensor connection	2 x (2-wire)				
Temperature range	-100 ... +1370 °C		Sensor-specific		
Resolution (over entire range)	0.1 °C				
Conversion time (typ.)	320 ms				
Internal resistance	1000 kΩ				
Measurement error (25 °C)	< ±6 K (voltage input < ±2 K; cold junction compensation < ±4 K)				
Temperature coefficient	< ±0.2 K/K				
Cold junction compensation	at each pair of terminal blocks				
Current consumption (5 V system supply)	65 mA				
Data width	2 x 16-bit data; 2 x 8-bit control/status (optional)				
Isolation	500 V system/field				
Ambient temperature (operation)	0 ... +55 °C				
Dimensions W x H x D	(12 x 100 x 69.8) mm				
Approvals	CE; Marine; OrdLoc/HazLoc; ATEX/IECEx				
For data sheet and additional information, see:	wago.com/750-469	wago.com/753-469	wago.com/750-469/000-200	wago.com/753-469/003-000	
Accessories	Item no.	Item no.	Item no.	Item no.	Item no.
Plug	-	753-110	-	-	753-110

7.4

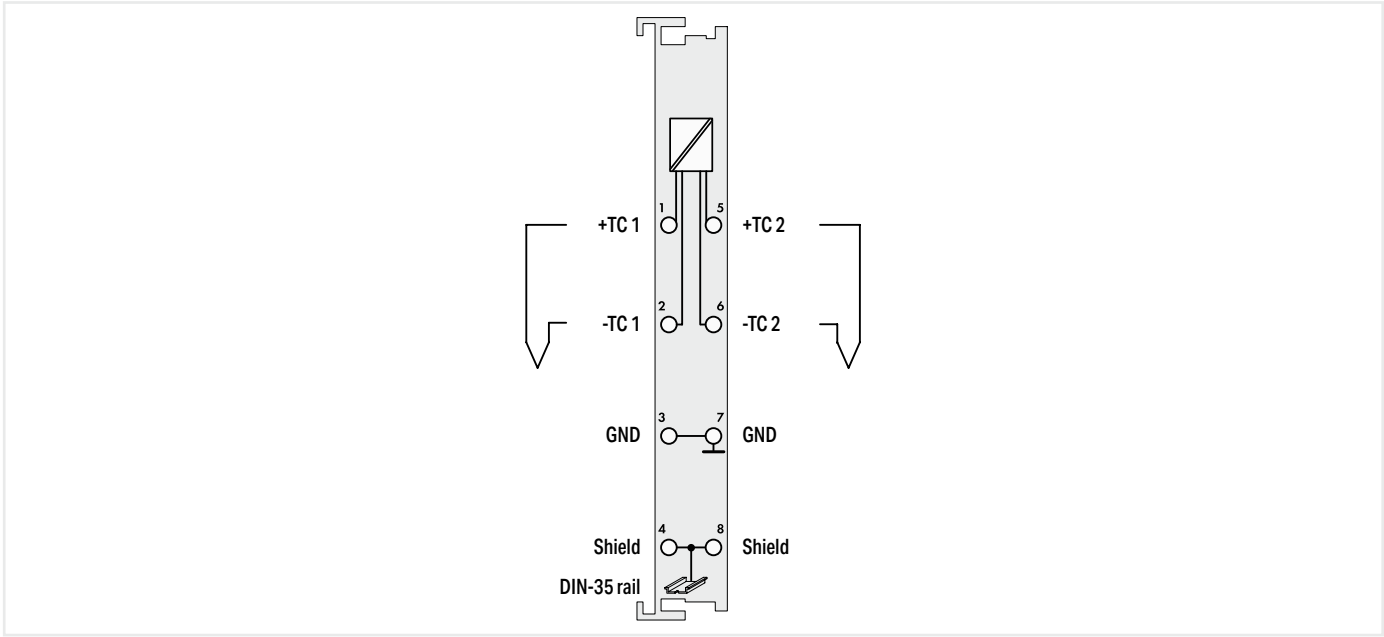

2-Channel Analog Input; Thermocouple; Diagnostics					
Thermocouple S	Thermocouple T	Thermocouple J	Thermocouple E	Thermocouple L	Thermocouple ±120 mV
750-469/000-001	750-469/000-002	750-469/000-006	750-469/000-008	750-469/000-012	750-469/000-003
2AI; TC S; Diagn	2AI; TC T; Diagn	2AI; TC J; Diagn	2AI; TC E; Diagn	2AI; TC L; Diagn	2AI; TC ±120mV; Diagn

-	-	-	-	-	-
---	---	---	---	---	---

2					
Thermocouple S	Thermocouple T	Thermocouple J	Thermocouple E	Thermocouple L	Low voltages ±120 mV
2 x (2-wire)					
-50 ... +1700 °C	-100 ... +400 °C	-100 ... +1200 °C	-100 ... +1000 °C	-100 ... +900 °C	-
0.1 °C					
320 ms					
1000 kΩ					
< ±6 K (voltage input < ±2 K; cold junction compensation < ±4 K)					
< ±0.2 K/K					
at each pair of terminal blocks					
65 mA					
2 x 16-bit data; 2 x 8-bit control/status (optional)					
500 V system/field					
0 ... +55 °C					
(12 x 100 x 69.8) mm					
CE; Marine; OrdLoc/HazLoc; ATEX/IECEx wago.com/750-469/000-001					
Item no.	Item no.	Item no.	Item no.	Item no.	Item no.
-	-	-	-	-	-

Analog input ► Thermocouples



750-498

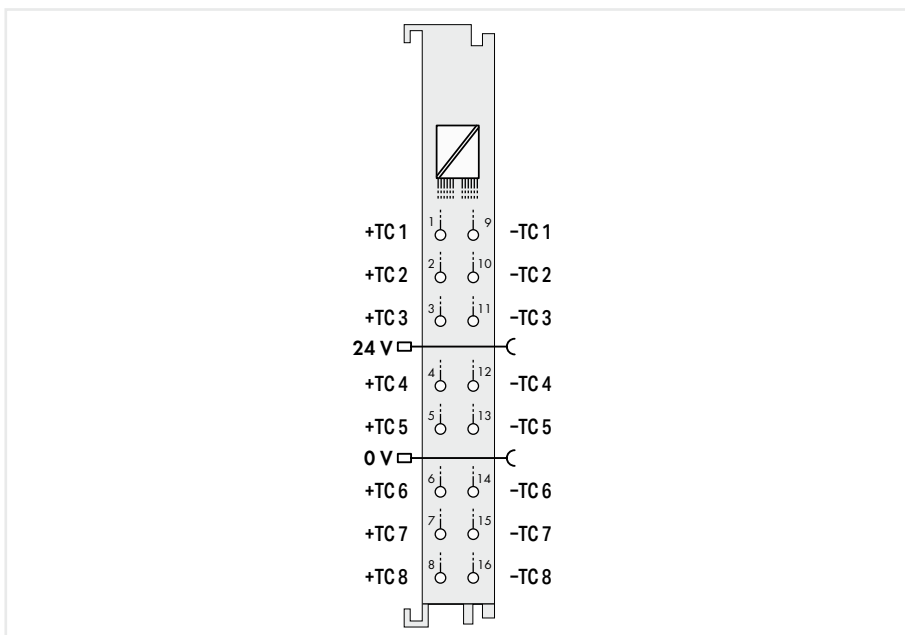

Item description	8-Channel Analog Input; Thermocouple; Adjustable
Version	Standard with 16 connectors
Item no.	750-498
Order Text	8AI; TC; Adjust
Technical data	
Number of analog inputs	8
Signal type	Thermocouple; Low voltages
Sensor types	Type K, J, B, E, N, R, S, T, C; Voltage measurement: ± 30 mV; ± 60 mV; ± 120 mV; ± 240 mV
Sensor connection	8 x (2-wire)
Resolution (over entire range)	0.1 °C
Measurement error (25 °C)	with cold junction compensation: $\leq \pm 1$ K (type E, N, K, T, J) at ≥ -50 °C; $\leq \pm 2$ K (type S, R, C) at ≥ 100 °C; $\leq \pm 3$ K (type B) at ≥ 350 °C; (Please find additional measurement error information in the manual.)
Temperature coefficient	Type K: ± 0.05 K/K of the upper-range value; Voltage measurements: ± 50 ppm/K of the upper-range value
Temperature error (max.) of the upper-range value	0.05 %/K
Cold junction compensation	Module-internal based on a cold junction temperature measurement
Supply voltage (field)	24 VDC (-25 ... +30 %); via power jumper contacts (power supply via blade contact; transmission via spring contact)
Current consumption (5 V system supply)	100 mA
Data width	8 x 16-bit data; 8 x 8-bit control/status (optional)
Isolation	500 V system/field
Ambient temperature (operation)	0 ... +55 °C
Dimensions W x H x D	(12 x 100 x 69) mm
Approvals	CE; Marine; OrdLoc/HazLoc; ATEX/IECEx

For data sheet and additional information, see:

wago.com/750-498

Analog input ► Resistor bridge (strain gauge)



750-491

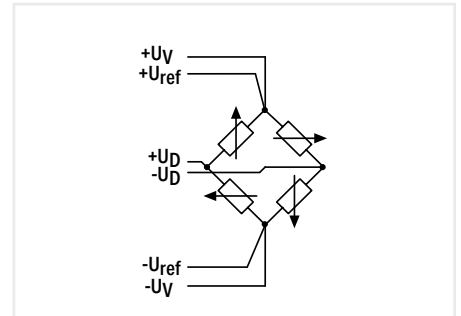
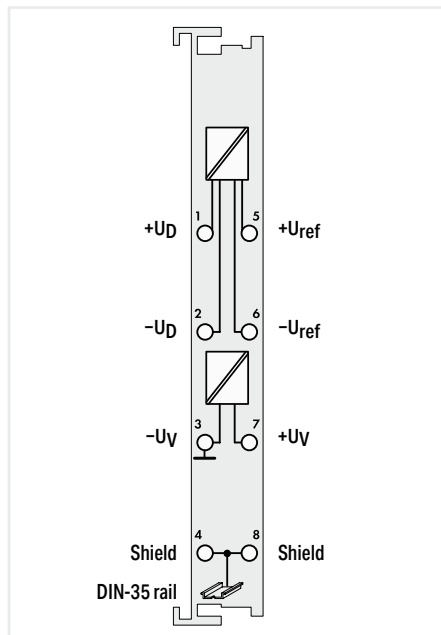

Item description	1-Channel Analog Input; Resistor bridges (strain gauge)	
Version	Standard	Conversion time: 125 ms
Item no.	750-491	750-491/000-001
Order Text	1AI; DMS	1AI; DMS; 125ms
Technical data		
Number of analog inputs	1	
Signal type	Resistor bridge (strain gauge)	
Signal voltage U_D	-15 ... +15 mV	
Signal voltage U_{ref}	2 ... 6 V	
Supply voltage (sensor)	5 VDC; Supply voltage U_V	
Resolution [bit]	16 bits	
Conversion time (typ.)	500 ms	
Measurement error	U_D : $\pm 30 \mu\text{V}$; U_{ref} : $\pm 10 \text{ mV}$	
Filter	50 Hz	200 Hz
Current consumption (5 V system supply)	65 mA	
Data width	2 x 16-bit data; 2 x 8-bit control/status (optional)	
Isolation	500 V system/field	
Ambient temperature (operation)	0 ... +55 °C	
Dimensions W x H x D	(12 x 100 x 69.8) mm	
Approvals	CE,	
For data sheet and additional information, see:	wago.com/750-491	

Analog input ▶ Resistor bridge (strain gauge)



750-1491

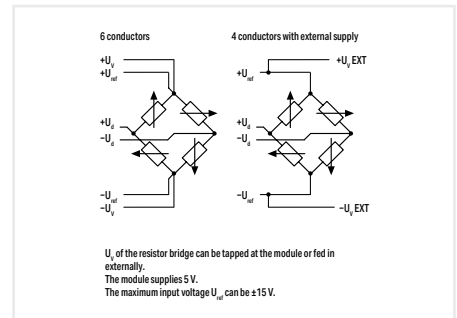
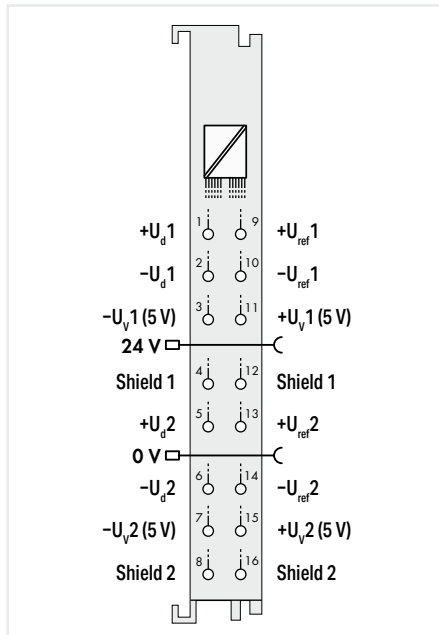

Item description	2-Channel Analog Input; Resistor bridges (strain gauge)
Version	Standard with 16 connectors
Item no.	750-1491
Order Text	2AI Resistor Bridge (Strain Gauge)
Technical data	
Number of analog inputs	2
Signal type	Resistor bridge (strain gauge)
Signal voltage U_D	$\pm 15 \text{ mV}; \pm 30 \text{ mV}; \pm 60 \text{ mV}; \pm 120 \text{ mV}; \pm 240 \text{ mV}; \pm 360 \text{ mV}$
Signal voltage U_{ref}	Internal $\pm 5 \text{ V}$; external $\pm 5 \text{ V}; \pm 10 \text{ V}; \pm 15 \text{ V}$
Supply voltage (sensor)	5 VDC
Resolution [bit]	16 bits
Measurement error (25 °C)	U_D : $\pm 30 \mu\text{V}$; U_{ref} : $\pm 0.05 \%$ of the upper-range value
Current consumption (5 V system supply)	70 mA
Data width	4 x 16-bit data; 4 x 8-bit control/status (optional)
Isolation	per UL 61010-2-201: 1.2 kVDC system/channel and channel/channel
Ambient temperature (operation)	0 ... +55 °C
Dimensions W x H x D	(12 x 100 x 69) mm
Approvals	CE, IEC, OrdLoc/HazLoc
For data sheet and additional information, see:	wago.com/750-1491

Analog input; Power measurement ► Three-phase power measurement



750-493

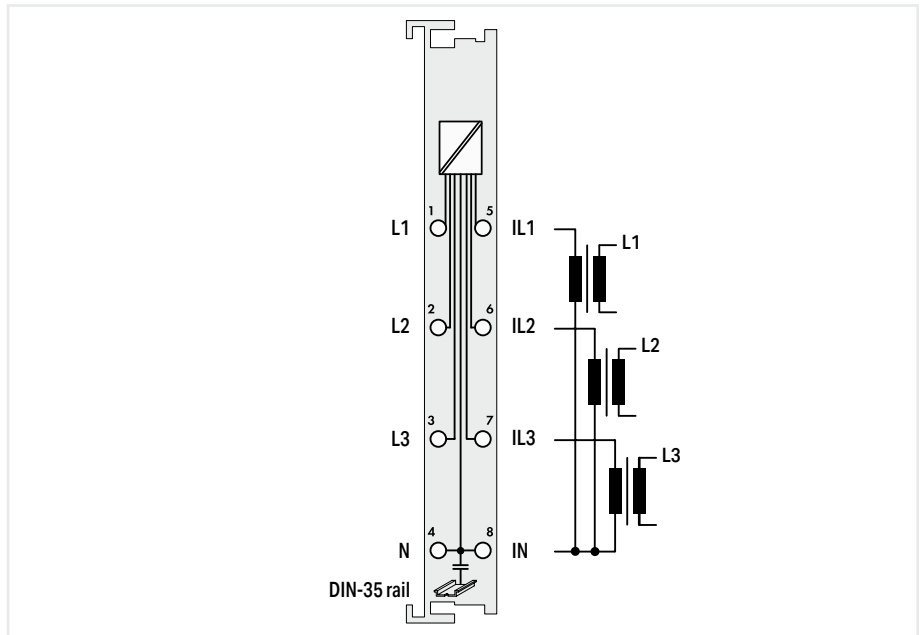

Item description		3-Phase Power Measurement; 480 VAC 1 A	
Version		Standard	ext. temperature
Item no.	750-493	750-493/025-000	480 VAC, 5 A
Order Text	3-PHASE POM; 480VAC 1A	3-PHASE POM; 480VAC 1A; T	750-493/000-001
			3-PHASE POM; 480VAC 5A
Technical data			
Signal type	Power measurement		
Calculated values	Active power, active energy, grid frequency, cos φ		
Measured variable	Voltage; Current; Effective power; reactive power; apparent power; Energy consumption; Frequency; cos phi		
Number of measurement inputs	6 (3 voltage measurement inputs, 3 current measurement inputs)		
Rated voltage	$U_{LN} = 277 \text{ V AC/DC}; U_{LL} = 480 \text{ VAC}$	$U_{LN} = 277 \text{ VAC/DC}; U_{LL} = 480 \text{ VAC}$	
Voltage path input resistance (typ.)		1071 kΩ	
Measurement current (max.)	1 A	1 A	5 A
Current path input resistance (typ.)		0.022 Ω	0.005 Ω
Resolution [bit]	16 bits		
Measurement method	True RMS measurement		
Reference for measurement error	AC current/voltage		
Measurement error (reference temperature)	25 °C		
Measurement error, deviation (max.) from the upper-range value	0.5 %	0.6 %	0.5 %
Frequency range (mains frequency)	45 ... 65 Hz		
Limit frequency	7.2 kHz		
Signal form	Any periodic signals (considering the threshold frequencies)	Any (taking the maximum frequency into account)	
Current consumption (5 V system supply)	100 mA		
Rated surge voltage	4 kV		
Data width	2 x 48-bit data; 2 x 24-bit control/status (optional)		
Isolation	4 kV system/field		
Ambient temperature (operation)	0 ... +55 °C	-20 ... +60 °C	0 ... +55 °C
Dimensions W x H x D	(12 x 100 x 67.8) mm		
Approvals	CE, OrdLoc/HazLoc, ATEX/IECEX		
For data sheet and additional information, see:	wago.com/750-493		

Analog input; Power measurement ► Three-phase power measurement



750-494/000-005

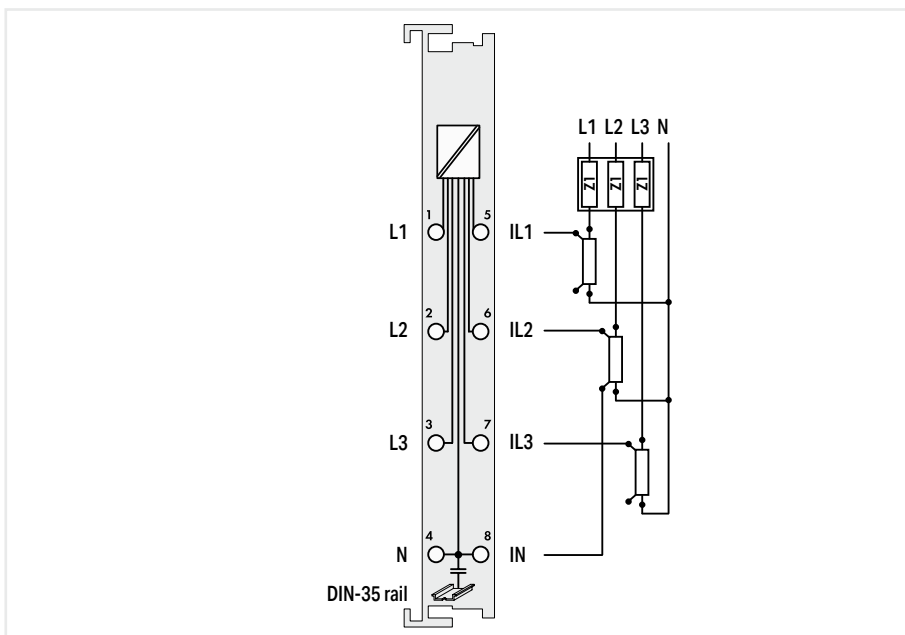

Item description	Power Measurement; 277 VAC/DC; external shunts
Version	Standard
Item no.	750-494/000-005
Order Text	Power measurement; 277 VAC/DC; external shunts
Technical data	
Signal type	Power measurement
Calculated values	Line-to-line voltage, power output, energy, power factors, mains frequency, harmonic analysis (up to the 41st harmonic), THD
Measured variable	Line-to-line voltage; Effective power; reactive power; apparent power; Energy sources; Power factor; Mains frequency; Harmonics analysis (up to 41st harmonic); THD
Number of measurement inputs	6 (3 voltage measurement inputs*, 3 current measurement inputs*) *Only 2 voltage/current measurement inputs can be used for DC measurement!
Rated voltage	$V_{LN} = 277 \text{ V AC/DC}; V_{LL} = 480 \text{ V AC}$
Voltage path input resistance (typ.)	1072 k Ω
Measurement current (max.)	1 ... 20,000 A via ext. shunts (DIN 43703, DIN EN 60051 (50 ... 300 mV))
Current path input resistance (typ.)	15000 Ω
Resolution [bit]	24 bits
Measurement method	True RMS measurement
Reference for measurement error	AC current/voltage
Measurement error (reference temperature)	25 °C
Measurement error, deviation (max.) from the upper-range value	0.5 %
Reference for measurement error (2)	AC current/voltage; DC measurement (2 channels only)
Measurement error, reference temperature (2)	25 °C
Measurement error, deviation (max.) of the upper-range value (2)	1 %
Frequency range (mains frequency)	45 ... 65 Hz
Frequency range (harmonics analysis)	0 ... 3300 Hz
Limit frequency	15.9 kHz
Signal form	Any periodic signals (considering the threshold frequencies)
Current consumption (5 V system supply)	100 mA
Data width	2 x 128-bit data; 2 x 64-bit control/status
Isolation	4 kV system/field
Ambient temperature (operation)	0 ... +55 °C
Dimensions W x H x D	(12 x 100 x 69.8) mm
Approvals	CE; Marine; OrdLoc/HazLoc; ATEX/IECEx

For data sheet and additional information, see:

wago.com/750-494/000-005

Analog input; Power measurement ▶ Three-phase power measurement



750-494

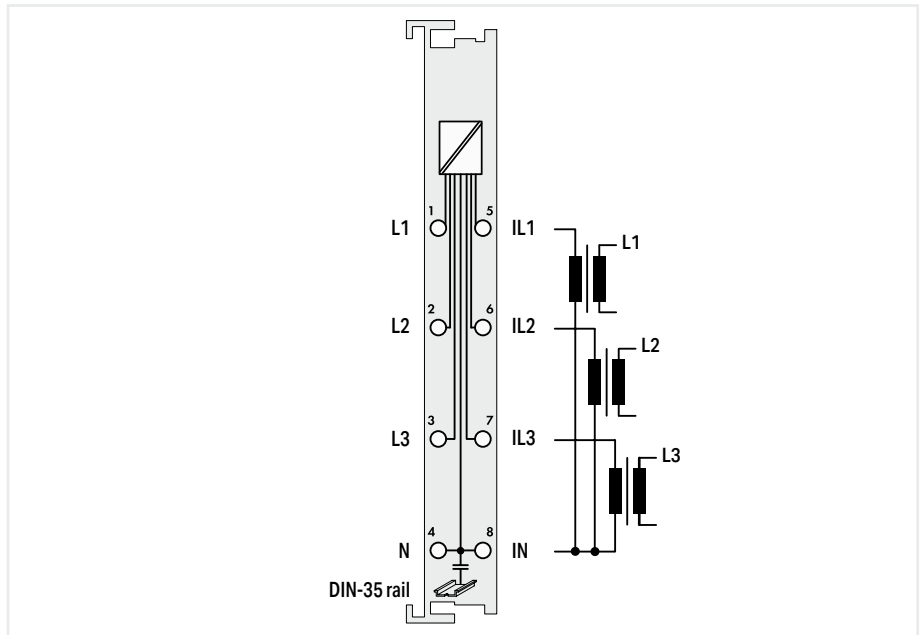

Item description				
Version				
Item no.				
Order Text				
3-Phase Power Measurement; 480 VAC 1 A				
Standard	ext. temperature	480 VAC, 5 A	480 VAC 5 A; extended temperature	
750-494	750-494/025-000	750-494/000-001	750-494/025-001	
3-PHASE POM; 480VAC 1A	3-PHASE POM; 480VAC 1A; T	3-PHASE POM; 480VAC 5A	3-PHASE POM; 480VAC 5A; T	

Technical data				
Signal type				
Calculated values				
Measured variable				
Number of measurement inputs				
Rated voltage				
Voltage path input resistance (typ.)				
Measurement current (max.)				
Current path input resistance (typ.)				
Resolution [bit]				
Measurement method				
Reference for measurement error				
Measurement error (reference temperature)				
Measurement error, deviation (max.) from the upper-range value				
Frequency range (mains frequency)				
Frequency range (harmonics analysis)				
Limit frequency				
Signal form				
Current consumption (5 V system supply)				
Rated surge voltage				
Data width				
Isolation				
Ambient temperature (operation)				
Dimensions W x H x D				
Approvals				

Power measurement			
Line-to-line voltage, power output, energy, power factors, mains frequency, harmonic analysis (up to the 41st harmonic), THD			
Voltage; Current; Effective power; reactive power; apparent power; Energy consumption; Frequency; cos phi; Harmonics (up to 41st harmonic); THD			
6 (3 voltage measurement inputs, 3 current measurement inputs)			
$U_{LN} = 277 \text{ VAC/DC}; U_{LL} = 480 \text{ VAC}$			
1072 kΩ			
1 A		5 A	
0.022 Ω		0.005 Ω	
24 bits			
True RMS measurement			
AC current/voltage			
25 °C			
0.5 %			
45 ... 65 Hz			
0 ... 3300 Hz			
15.9 kHz			
Any periodic signals (considering the threshold frequencies)			
100 mA			
4 kV			
2 x 128-bit data; 2 x 64-bit control/status			
4 kV system/field			
0 ... +55 °C		-20 ... +60 °C	
0 ... +55 °C		-20 ... +60 °C	
(12 x 100 x 67.8) mm			
CE; Marine; OrdLoc/HazLoc; ATEX/IECEx			
wago.com/750-494			

For data sheet and additional information, see:

Analog input; Power measurement ▶ Three-phase power measurement



750-495

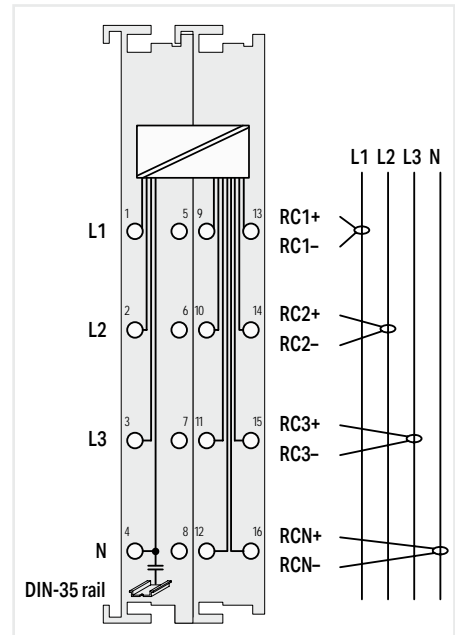
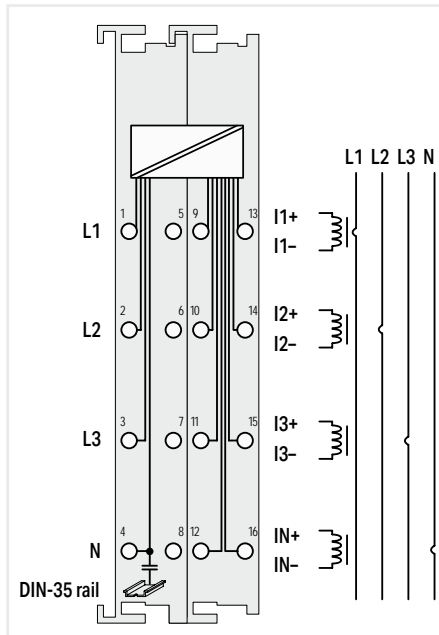

Item description	3-Phase Power Measurement; 690 VAC 1 A		3-Phase Power Measurement; 690 VAC Rogowski coils
Version	Standard	690 VAC 5 A	690 VAC Rogowski coils
Item no.	750-495	750-495/000-001	750-495/000-002
Order Text	3-PHASE POM; 690VAC 1A	3-PHASE POM; 690VAC 5A	3-PHASE POM; 690VAC R.C.
Technical data	Power measurement		Power measurement
Signal type	Line-to-line voltage, power output, energy, power factors, mains frequency, harmonic analysis (up to the 41st harmonic), THD		Line-to-line voltage, power output, energy, power factors, mains frequency, harmonic analysis (up to the 41st harmonic), THD
Calculated values	Voltage; Current; Effective power; reactive power; apparent power; Energy consumption; Frequency; cos phi; Harmonics (up to 41st harmonic); THD; Current measurement in N-conductor		Voltage; Current; Effective power; reactive power; apparent power; Energy consumption; Frequency; cos phi; Harmonics (up to 41st harmonic); THD; Current measurement in N-conductor
Measured variable	7 (3 voltage measurement inputs, 4 differential current measurement inputs)	7 (3 Spannungsmessingänge, 4 differentielle Strommessingänge)	7 (3 Spannungsmessingänge, 4 differentielle Strommessingänge)
Number of measurement inputs	$V_{LN} = 400 \text{ V AC}; V_{LL} = 690 \text{ V AC}$	$U_{LN} = 400 \text{ V AC}; U_{LL} = 690 \text{ V AC}$	$V_{LN} = 400 \text{ VAC}; V_{LL} = 690 \text{ VAC}$
Rated voltage	1429 kΩ		1429 kΩ
Voltage path input resistance (typ.)	1 A	5 A	Rogowski Coils RT500/RT2000
Measurement current (max.)	0.022 Ω	0.005 Ω	44000 Ω
Current path input resistance (typ.)	24 bits		24 bits
Resolution [bit]	True RMS measurement		True RMS measurement
Measurement method	AC current/voltage		AC current/voltage
Reference for measurement error	25 °C		25 °C
Measurement error (reference temperature)	0.5 %		0.5 %
Measurement error, deviation (max.) from the upper-range value	45 ... 65 Hz		45 ... 65 Hz
Frequency range (mains frequency)	0 ... 3300 Hz		0 ... 3300 Hz
Frequency range (harmonics analysis)	15.9 kHz		15.9 kHz
Limit frequency	Any periodic signals (considering the threshold frequencies)		Any periodic signals (considering the threshold frequencies)
Signal form	100 mA		100 mA
Current consumption (5 V system supply)	6 kV		6 kV
Rated surge voltage	2 x 128-bit data; 2 x 64-bit control/status		2 x 128-bit data; 2 x 64-bit control/status
Data width	6 kV system/field		6 kV system/field
Isolation	0 ... +55 °C		0 ... +55 °C
Ambient temperature (operation)	(24 x 100 x 67.8) mm		(24 x 100 x 67.8) mm
Dimensions W x H x D	Marine wago.com/750-495		Marine wago.com/750-495
Approvals	For data sheet and additional information, see:		For data sheet and additional information, see:

Analog Output Modules



Housing Design (750 Series)

Dimensions W x H x D	12 x 100 x 69.8 mm
Depth from upper edge of DIN-rail	62.6 mm
Connection technology	CAGE CLAMP®
Conductor cross-section	0.08 ... 2.5 mm ² / 28 ... 14 AWG
Strip length	8 ... 9 mm / 0.33 inch

Housing Design (753 Series)

Dimensions W x H x D	12 x 100 x 69.8 mm
Depth from upper edge of DIN-rail	62.6 mm
Connection technology	CAGE CLAMP®
Conductor cross-section	0.08 ... 2.5 mm ² / 28 ... 14 AWG
Strip length	9 ... 10 mm / 0.37 inch

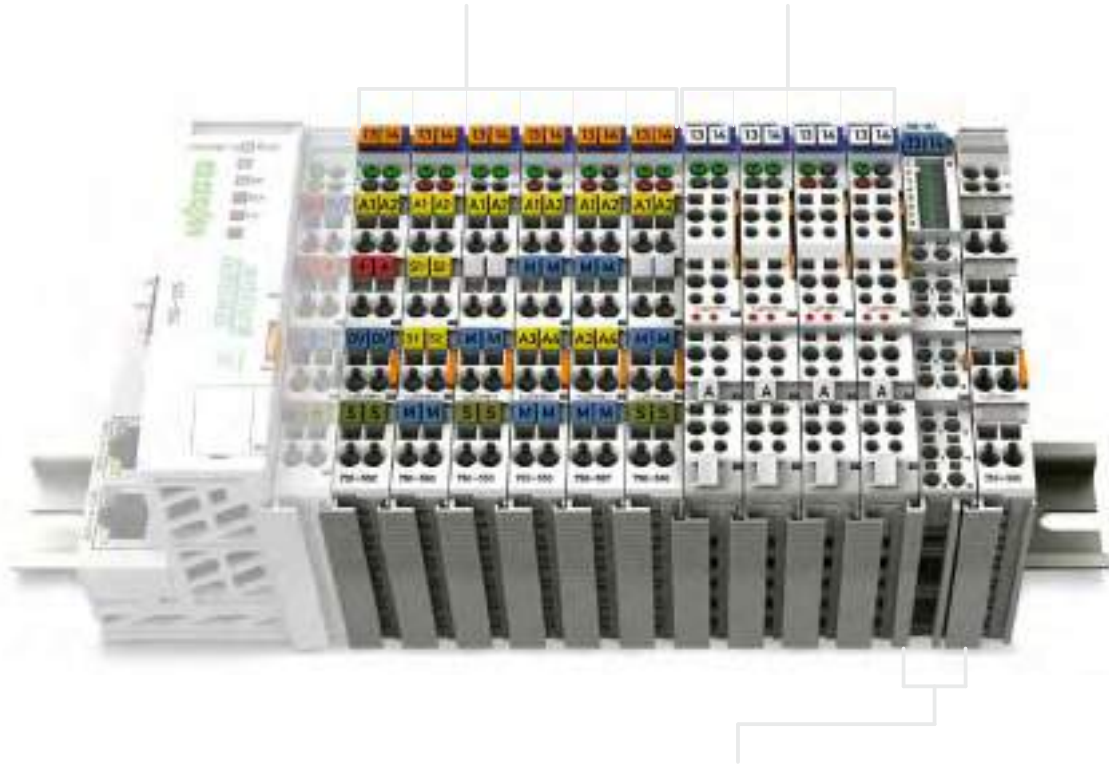

Housing Design (750 Series), with Push-in CAGE CLAMP® Connections (up to 16 connection points)

Dimensions W x H x D	12 x 100 x 69 mm
Depth from upper edge of DIN-rail	61.8 mm
Connection technology	Push-in CAGE CLAMP®
Conductor cross-section	Solid: 0.08 ... 1.5 mm ² / 28 ... 16 AWG Fine-stranded: 0.25 ... 1.5 mm ² / 22 ... 16 AWG
Strip length	8 ... 9 mm / 0.33 inch



I/O System –
750 XTR Series



I/O System – 750 and 753 Series, Analog Output Modules

Contents

Function	2-Channel AO	4-Channel AO	8-Channel AO	Description	Item Number				Page
					Standard	/S5 Customized Data Format	Extended Temperature	Pluggable	
0 ... 20 mA	■			2-Channel Analog Output; 0 ... 20 mA	750-552	750-552/000-200	750-552/025-000	753-552	362
		■		4-Channel Analog Output; 0 ... 20 mA	750-553			753-553	363
4 ... 20 mA	■			2-Channel Analog Output; 4 ... 20 mA	750-554	750-554/000-200	750-554/025-000	753-554	364
		■		4-Channel Analog Output; 4 ... 20 mA	750-555			753-555	365
0/4 ... 20 mA	■			2-Channel Analog Output; 0/4 ... 20 mA; 16 Bits; 6 ... 18 VDC	750-563*				366
±10 V	■			2-Channel Analog Output; ±10 VDC	750-556	750-556/000-200		753-556	367
		■		4-Channel Analog Output; ±10 VDC	750-557*			753-557	368
0 ... 10 V	■			2-Channel Analog Output; 0 ... 10 VDC; 10 Bits; 100 mW/24 V	750-560				369
	■			2-Channel Analog Output; 0 ... 10 VDC	750-550	750-550/000-200		753-550	370
		■		4-Channel Analog Output; 0 ... 10 VDC	750-559*		750-559/025-000	753-559	371
0 ... 10 V/±10 V	■			2-Channel Analog Output; 0 ... 10 VDC/±10 V; 16 Bits	750-562				372
			■	8-Channel Analog Output; 0 ... 10 VDC/±10 V	750-597				373
Voltage/Current		■		4-Channel Analog Output; Voltage/Current	750-564				374
Ex i					See Section 7.9				
*This module is also available as a variant of the 750 XTR Series.					See Section 8				

Analog output ▶ 0 ... 20 mA



750-552

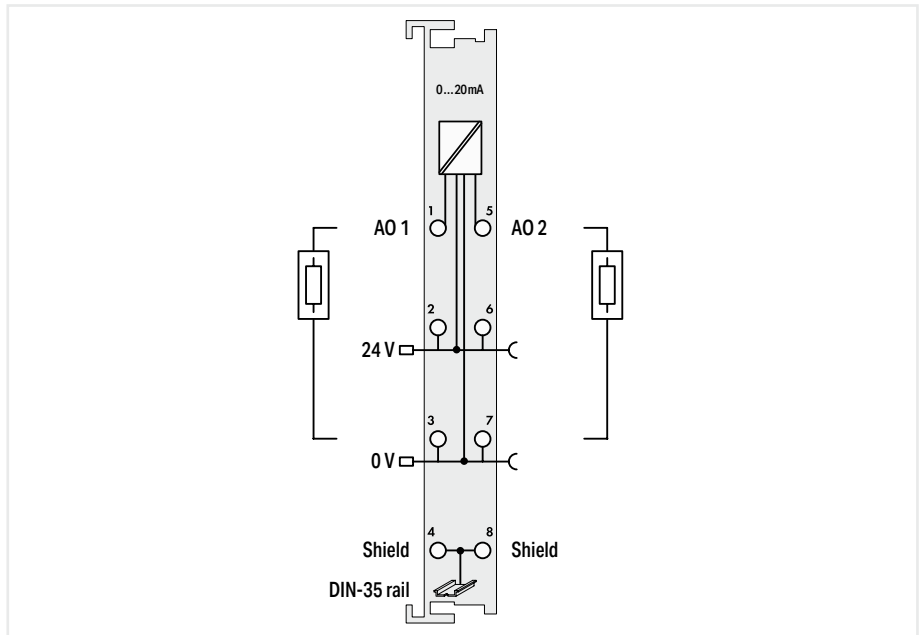

Item description	2-Channel Analog Output; 0 ... 20 mA			
Version	Standard	ext. temperature	pluggable (delivery without connector)	Data format (S5 control)
Item no.	750-552	750-552/025-000	753-552	750-552/000-200
Order Text	2AO; 0-20mA	2AO; 0-20mA; T	2AO; 0-20mA	2AO; 0-20mA; S5

Technical data				
Pluggable connector	-		pluggable	
Customized data format	-			The S5 format allows you to import data with the standard S5 FB 250 function block.
Number of analog outputs	2			
Signal type	Current			
Signal type (current)	0 ... 20 mA DC			
Actuator connection	2 x (2-wire)			
Load impedance (current output)	≤ 600 Ω			
Resolution [bit]	12 bits			
Conversion time (typ.)	2 ms			
Linearity	±10 μA			
Output error, reference temperature	25 °C			
Output error, deviation (max.) of the upper-range value	0.1 %			
Temperature error (max.) of the output range value	0.01 %/K			
Supply voltage (field)	24 VDC (-25 ... +30 %); via power jumper contacts (power supply via blade contact; transmission via spring contact)			
Current consumption (5 V system supply)	70 mA			
Data width	2 x 16-bit data; 2 x 8-bit control/status (optional)			
Isolation	500 V system/field			
Ambient temperature (operation)	0 ... +55 °C	-20 ... +60 °C	0 ... +55 °C	
Dimensions W x H x D	(12 x 100 x 69.8) mm			
Approvals	CE; Marine; OrdLoc/HazLoc; ATEX/IECEx			

For data sheet and additional information, see: wago.com/750-552 wago.com/753-552 wago.com/750-552/000-200

Accessories	Item no.	Item no.	Item no.	Item no.
Plug	-	-	753-110	-

7.5

Analog output ► 0 ... 20 mA



750-553

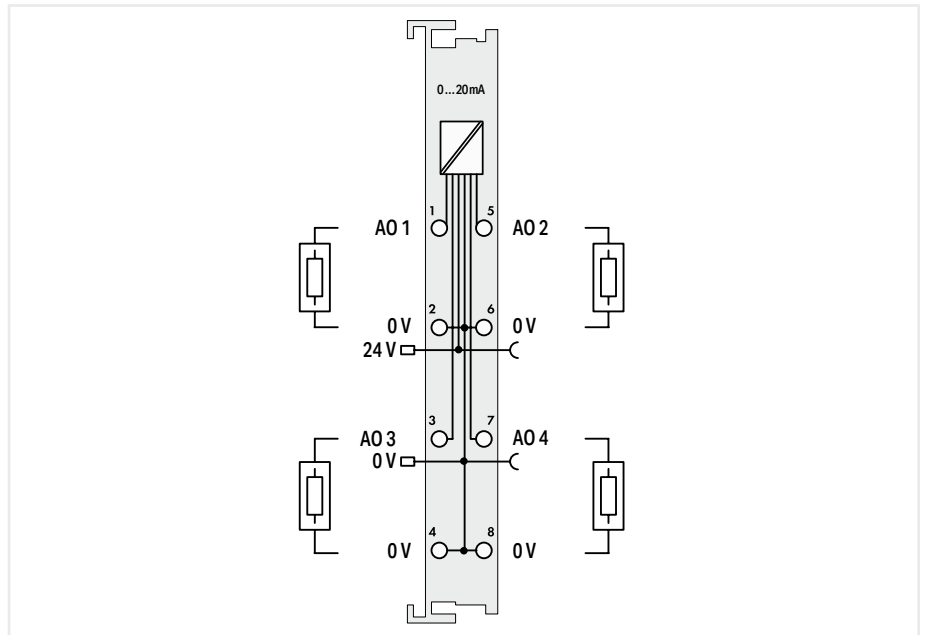

Item description	4-Channel Analog Output; 0 ... 20 mA	
Version	Standard	pluggable (delivery without connector)
Item no.	750-553	753-553
Order Text	4AO; 0-20mA	4AO; 0-20mA
Technical data		
Pluggable connector	-	pluggable
Number of analog outputs		4
Signal type		Current
Signal type (current)		0 ... 20 mA DC
Actuator connection		4 x (2-wire)
Load impedance		Either 0 ... 300 Ω or 300 ... 600 Ω (same resistance for all load impedances)
Resolution [bit]		12 bits
Conversion time (typ.)		10 ms
Output error, reference temperature		25 °C
Output error, deviation (max.) of the upper-range value		0.1 %
Temperature error (max.) of the output range value		0.01 %/K
Supply voltage (field)	24 VDC (-25 ... +30 %); via power jumper contacts (power supply via blade contact; transmission via spring contact)	
Current consumption (5 V system supply)		60 mA
Data width	4 x 16-bit data; 4 x 8-bit control/status (optional)	
Isolation		500 V system/field
Ambient temperature (operation)		0 ... +55 °C
Dimensions W x H x D		(12 x 100 x 69.8) mm
Approvals	CE; Marine; OrdLoc/HazLoc; ATEX/IECEx	
For data sheet and additional information, see:	wago.com/750-553	wago.com/753-553
Accessories	Item no.	Item no.
Plug	-	753-110

Analog output ▶ 4 ... 20 mA



750-554

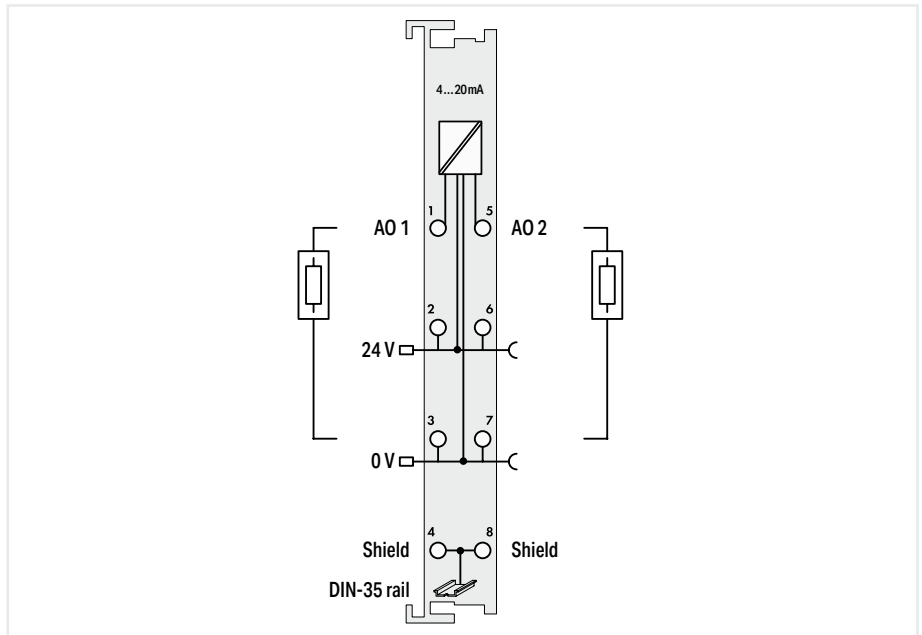

Item description				
Version				
Item no.	750-554	750-554/025-000	753-554	750-554/000-200
Order Text	2AO; 4-20mA	2AO; 4-20mA; T	2AO; 4-20mA	2AO; 4-20mA; S5
Technical data				
Pluggable connector	-		pluggable	-
Customized data format	-			The S5 format allows you to import data with the standard S5 FB 250 function block.
Number of analog outputs	2			
Signal type	Current			
Signal type (current)	4 ... 20 mA DC			
Actuator connection	2 x (2-wire)			
Load impedance (current output)	≤ 600 Ω			
Resolution [bit]	12 bits			
Conversion time (typ.)	2 ms			
Linearity	±10 μA			
Output error, reference temperature	25 °C			
Output error, deviation (max.) of the upper-range value	0.1 %			
Temperature error (max.) of the output range value	0.015 %/K			
Supply voltage (field)	24 VDC (-25 ... +30 %); via power jumper contacts (power supply via blade contact; transmission via spring contact)			
Current consumption (5 V system supply)	70 mA			
Data width	2 x 16-bit data; 2 x 8-bit control/status (optional)			
Isolation	500 V system/field			
Ambient temperature (operation)	0 ... +55 °C	-20 ... +60 °C	0 ... +55 °C	
Dimensions W x H x D	(12 x 100 x 69.8) mm			
Approvals	CE; Marine; OrdLoc/HazLoc; ATEX/IECEx			
For data sheet and additional information, see:	wago.com/750-554		wago.com/753-554	wago.com/750-554/000-200
Accessories	Item no.	Item no.	Item no.	Item no.
Plug	-	-	753-110	-

7.5

Analog output ► 4 ... 20 mA



750-555

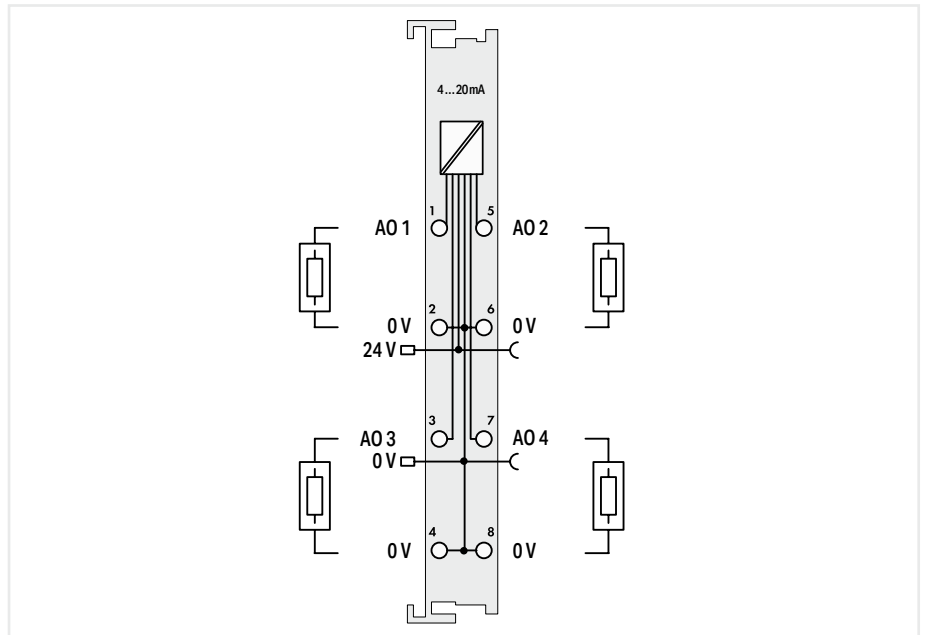

Item description	4-Channel Analog Output; 4 ... 20 mA	
Version	Standard	pluggable (delivery without connector)
Item no.	750-555	753-555
Order Text	4AO; 4-20mA	4AO; 4-20mA
Technical data		
Pluggable connector	-	pluggable
Number of analog outputs		4
Signal type		Current
Signal type (current)		4 ... 20 mA DC
Actuator connection		4 x (2-wire)
Load impedance		Either 0 ... 300 Ω or 300 ... 600 Ω (same resistance for all load impedances)
Resolution [bit]		12 bits
Conversion time (typ.)		10 ms
Output error, reference temperature		25 °C
Output error, deviation (max.) of the upper-range value		0.1 %
Temperature error (max.) of the output range value		0.01 %/K
Supply voltage (field)	24 VDC (-25 ... +30 %); via power jumper contacts (power supply via blade contact; transmission via spring contact)	
Current consumption (5 V system supply)		60 mA
Data width	4 x 16-bit data; 4 x 8-bit control/status (optional)	
Isolation		500 V system/field
Ambient temperature (operation)		0 ... +55 °C
Dimensions W x H x D		(12 x 100 x 69.8) mm
Approvals	CE; L Marine; OrdLoc/HazLoc; ATEX/IECEx	
For data sheet and additional information, see:	wago.com/750-555	wago.com/753-555
Accessories	Item no.	Item no.
Plug	-	753-110

Analog output ► Configurable: current/voltage



750-563

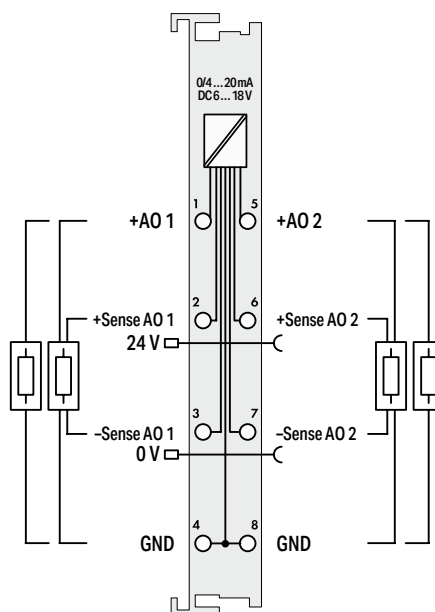

Item description	2-Channel Analog Output; 0/4 ... 20 mA; 16 Bits; 6 ... 18 VDC
Version	Standard
Item no.	750-563
Order Text	2AO; 0/4-20mA; 16bits; 6-18 VDC
Technical data	
Number of analog outputs	2
Signal type	Voltage; Current
Signal type (current)	0 ... 20 mADC; 4 ... 20 mADC
Signal type (voltage)	6 ... 18 VDC
Actuator connection	2 x (2-wire, 4-wire)
Load impedance (current output)	$\leq 500 \Omega$
Load impedance (voltage output)	$\geq 1.8 \text{ k}\Omega$
Resolution [bit]	16 bits
Conversion time (typ.)	5 ms
Output error, reference temperature	25 °C
Output error, deviation (max.) of the upper-range value	0.05 %
Temperature coefficient	$< \pm 100 \text{ ppm}$
Supply voltage (field)	24 VDC (-15 ... +20 %); via power jumper contacts (power supply via blade contact; transmission via spring contact)
Current consumption (5 V system supply)	95 mA
Data width	2 x 16-bit data; 2 x 8-bit control/status (optional)
Isolation	500 V system/field
Ambient temperature (operation)	0 ... +55 °C
Dimensions W x H x D	(12 x 100 x 69.8) mm
Approvals	CE; Marine; OrdLoc/HazLoc; ATEX/IECEx
For data sheet and additional information, see:	wago.com/750-563

Analog output ▶ ±10 V



750-556

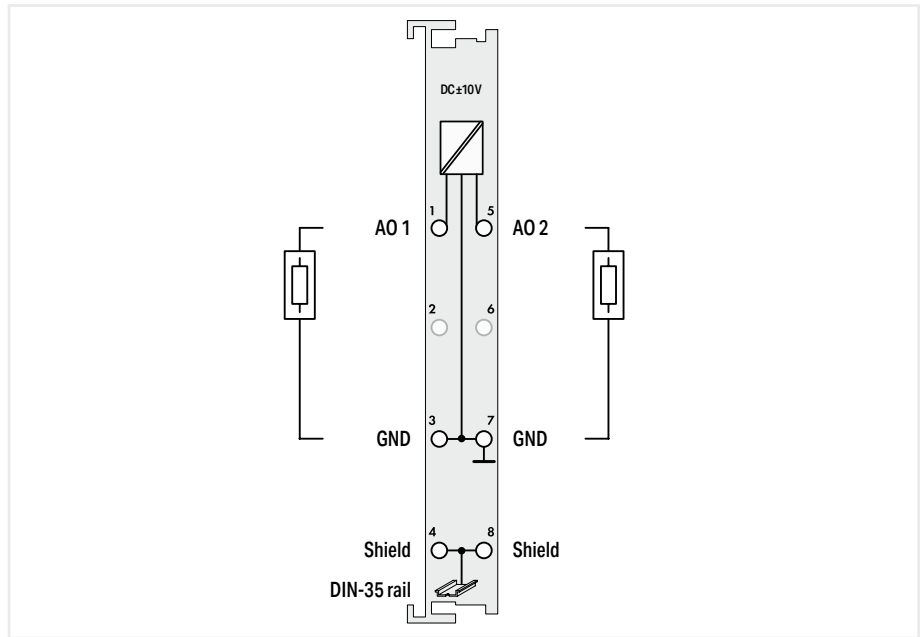

Item description	2-Channel Analog Output; ±10 VDC		
Version	Standard	pluggable (delivery without connector)	Data format (S5 control)
Item no.	750-556	753-556	750-556/000-200
Order Text	2AO; ±10 VDC	2AO; ±10 VDC	2AO; ±10 VDC; S5
Technical data			
Pluggable connector	-	pluggable	-
Customized data format	-	-	The S5 format allows you to import data with the standard S5 FB 250 function block.
Number of analog outputs	2		
Signal type	Voltage		
Signal type (voltage)	-10 ... +10 VDC		
Actuator connection	2 x (2-wire)		
Load impedance (voltage output)	≥ 5 kΩ		
Resolution [bit]	12 bits		
Conversion time (typ.)	2 ms		
Linearity	±10 mV		
Output error, reference temperature	25 °C		
Output error, deviation (max.) of the upper-range value	0.1 %		
Temperature error (max.) of the output range value	0.01 %/K		
Current consumption (5 V system supply)	65 mA		
Data width	2 x 16-bit data; 2 x 8-bit control/status (optional)		
Isolation	500 V system/field		
Ambient temperature (operation)	0 ... +55 °C		
Dimensions W x H x D	(12 x 100 x 69.8) mm		
Approvals	CE; Marine; OrdLoc/HazLoc; ATEX/IECEx		
For data sheet and additional information, see:	wago.com/750-556	wago.com/753-556	wago.com/750-556/000-200
Accessories	Item no.	Item no.	Item no.
Plug	-	753-110	-

Analog output ► ± 10 V

750-557

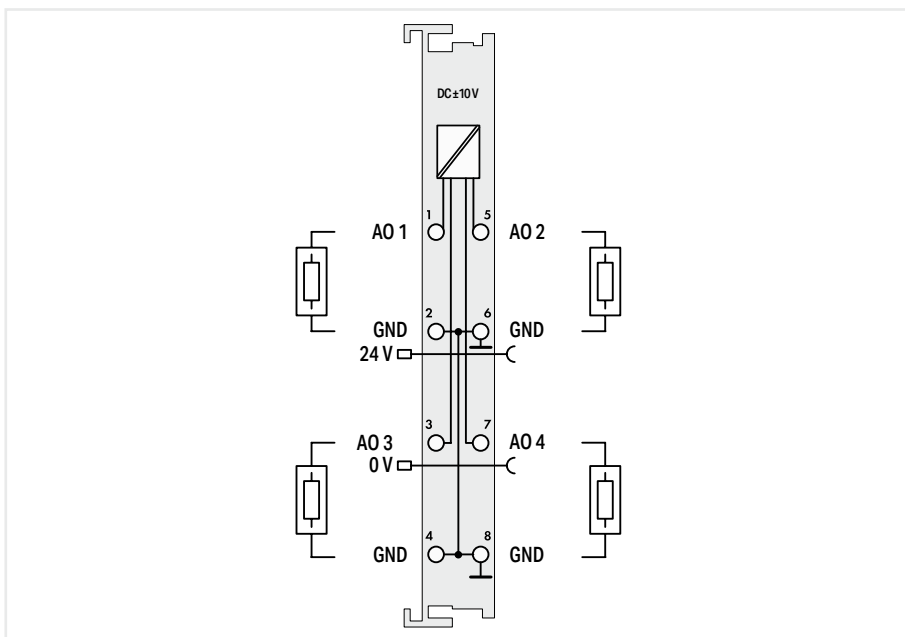

Item description	4-Channel Analog Output; ± 10 VDC	
Version	Standard	pluggable (delivery without connector)
Item no.	750-557	753-557
Order Text	4AO; ± 10 VDC	4AO; ± 10 VDC
Technical data		
Pluggable connector	-	pluggable
Number of analog outputs		4
Signal type		Voltage
Signal type (voltage)		-10 ... +10 VDC
Actuator connection		4 x (2-wire)
Load impedance (voltage output)		≥ 5 k Ω
Resolution [bit]		12 bits
Conversion time (typ.)		10 ms
Output error, reference temperature		25 °C
Output error, deviation (max.) of the upper-range value		0.1 %
Temperature error (max.) of the output range value		0.01 %/K
Supply voltage (field)	24 VDC (-25 ... +30 %); via power jumper contacts (power supply via blade contact; transmission via spring contact)	
Current consumption (5 V system supply)		125 mA
Data width	4 x 16-bit data; 4 x 8-bit control/status (optional)	
Isolation		500 V system/field
Ambient temperature (operation)		0 ... +55 °C
Dimensions W x H x D		(12 x 100 x 69.8) mm
Approvals	CE; Marine; OrdLoc/HazLoc; ATEX/IECEx	
For data sheet and additional information, see:	wago.com/750-557	wago.com/753-557
Accessories	Item no.	Item no.
Plug	-	753-110

Analog output ► 0 ... 10 V



750-560

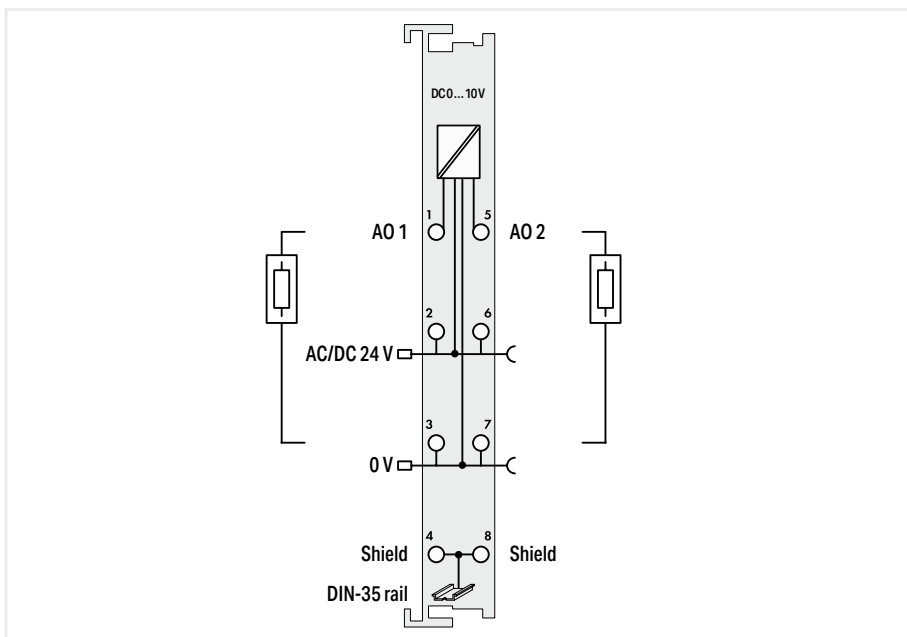

Item description	2-Channel Analog Output; 0 ... 10 VDC; 10 Bits; 100 mW/24 V
Version	Standard
Item no.	750-560
Order Text	2AO; 0-10 VDC; 10Bit; 100mW/ 24V
Technical data	
Number of analog outputs	2
Signal type	Voltage
Signal type (voltage)	0 ... 10 VDC
Actuator connection	2 x (2-wire)
Load impedance (voltage output)	≥ 1 kΩ
Resolution [bit]	10 bits
Conversion time (typ.)	10 ms
Output error, reference temperature	25 °C
Output error, deviation (max.) of the upper-range value	0.2 %
Temperature error (max.) of the output range value	0.02 %/K
Supply voltage (field)	24 VAC/DC (-25 ... +30 %); via power jumper contacts (power supply via blade contact; transmission via spring contact)
Current consumption (5 V system supply)	16 mA
Data width	2 x 16-bit data; 2 x 8-bit control/status (optional)
Isolation	500 V system/field
Ambient temperature (operation)	0 ... +55 °C
Dimensions W x H x D	(12 x 100 x 69.8) mm
Approvals	CE, OrdLoc/HazLoc; ATEX/IECEx
For data sheet and additional information, see:	wago.com/750-560

Analog output ► 0 ... 10 V



750-550

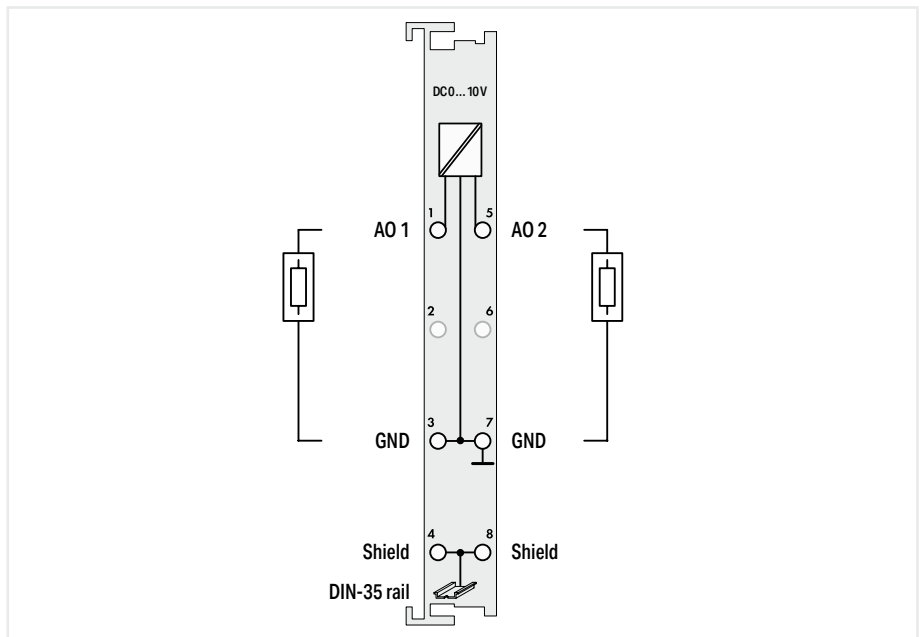

Item description			
Version			
Item no.	750-550	753-550	750-550/000-200
Order Text	2AO; 0-10 VDC	2AO; 0-10 VDC	2AO; 0-10 VDC; S5
Technical data			
Pluggable connector	-	pluggable	-
Customized data format	-	-	The S5 format allows you to import data with the standard S5 FB 250 function block.
Number of analog outputs	2		
Signal type	Voltage		
Signal type (voltage)	0 ... 10 VDC		
Actuator connection	2 x (2-wire)		
Load impedance (voltage output)	≥ 5 kΩ		
Resolution [bit]	12 bits		
Conversion time (typ.)	2 ms		
Linearity	±10 mV		
Output error, reference temperature	25 °C		
Output error, deviation (max.) of the upper-range value	0.1 %		
Temperature error (max.) of the output range value	0.01 %/K		
Current consumption (5 V system supply)	65 mA		
Data width	2 x 16-bit data; 2 x 8-bit control/status (optional)		
Isolation	500 V system/field		
Ambient temperature (operation)	0 ... +55 °C		
Dimensions W x H x D	(12 x 100 x 69.8) mm		
Approvals	Marine; OrdLoc/HazLoc; ATEX/IECEx		
For data sheet and additional information, see:	wago.com/750-550	wago.com/753-550	wago.com/750-550/000-200
Accessories	Item no.	Item no.	Item no.
Plug	-	753-110	-

Analog output ► 0 ... 10 V



750-559

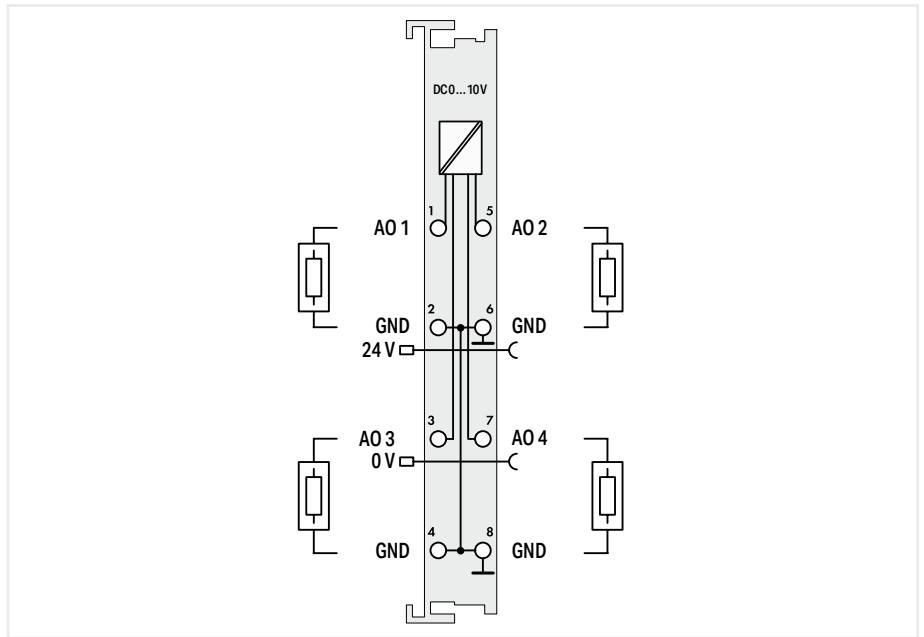

Item description			
Version			
Item no.	750-559	750-559/025-000	753-559
Order Text	4AO; 0-10 VDC	4AO; 0-10 VDC; T	4AO; 0-10 VDC
4-Channel Analog Output; 0 ... 10 VDC			
Standard		ext. temperature	pluggable (delivery without connector)
			pluggable
Technical data			
Pluggable connector			pluggable
Number of analog outputs	4		
Signal type	Voltage		
Signal type (voltage)	0 ... 10 VDC		
Actuator connection	4 x (2-wire)		
Load impedance (voltage output)	≥ 5 kΩ		
Resolution [bit]	12 bits		
Conversion time (typ.)	10 ms		
Output error, reference temperature	25 °C		
Output error, deviation (max.) of the upper-range value	0.1 %		
Temperature error (max.) of the output range value	0.01 %/K		
Supply voltage (field)	24 VDC (-25 ... +30 %); via power jumper contacts (power supply via blade contact; transmission via spring contact)		
Current consumption (5 V system supply)	125 mA		
Data width	4 x 16-bit data; 4 x 8-bit control/status (optional)		
Isolation	500 V system/field		
Ambient temperature (operation)	0 ... +55 °C	-20 ... +60 °C	0 ... +55 °C
Dimensions W x H x D	(12 x 100 x 69.8) mm		
Approvals	CE; L; Marine; OrdLoc/HazLoc; ATEX/IECEX		
For data sheet and additional information, see:	wago.com/750-559		wago.com/753-559
Accessories	Item no.	Item no.	Item no.
Plug	-	-	753-110

Analog output ► Configurable: voltage



750-562

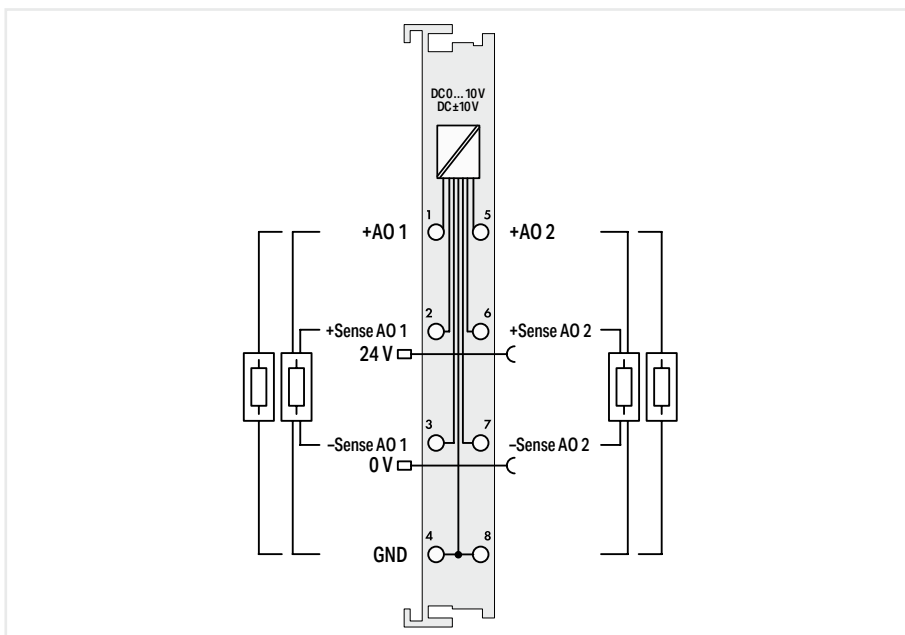

Item description	2-Channel Analog Output; 0 ... 10 VDC/±10 V; 16 bits
Version	Standard
Item no.	750-562
Order Text	2AO; 0-10 V/±10 VDC; 16bits
Technical data	
Number of analog outputs	2
Signal type	Voltage
Signal type (voltage)	0 ... 10 VDC; -10 ... +10 VDC
Actuator connection	2 x (2-wire, 4-wire)
Load impedance (voltage output)	≥ 5 kΩ
Resolution [bit]	16 bits
Conversion time (typ.)	5 ms
Output error, reference temperature	25 °C
Output error, deviation (max.) of the upper-range value	0.05 %
Temperature coefficient	< ±100 ppm
Supply voltage (field)	24 VDC (-15 ... +20 %); via power jumper contacts (power supply via blade contact; transmission via spring contact)
Current consumption (5 V system supply)	125 mA
Data width	2 x 16-bit data; 2 x 8-bit control/status (optional)
Isolation	500 V system/field
Ambient temperature (operation)	0 ... +55 °C
Dimensions W x H x D	(12 x 100 x 69.8) mm
Approvals	CE; OrdLoc/HazLoc; ATEX/IECEx
For data sheet and additional information, see:	wago.com/750-562

Analog output ► Configurable: voltage



750-597

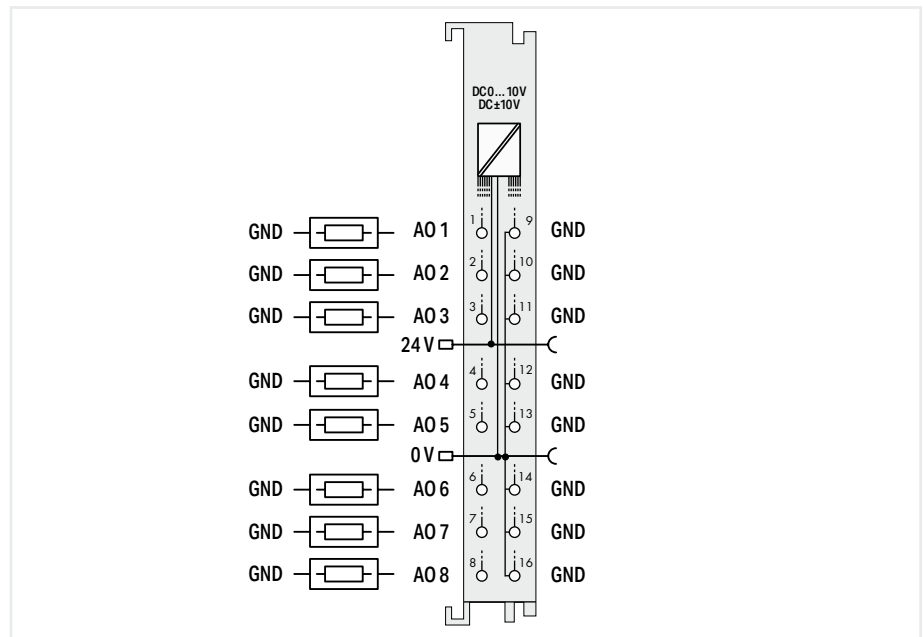

Item description	8-Channel Analog Output; 0 ... 10 VDC/±10 V
Version	Standard with 16 connectors
Item no.	750-597
Order Text	8AO; 0-10 V/±10 VDC
Technical data	
Number of analog outputs	8
Signal type	Voltage
Signal type (voltage)	0 ... 10 VDC
Actuator connection	8 x (2-wire)
Load impedance (voltage output)	≥ 2 kΩ
Resolution [bit]	12 bits
Conversion time (typ.)	13 ms
Output error, reference temperature	25 °C
Output error, deviation (max.) of the upper-range value	0.1 %
Temperature coefficient	≤ ±10 ppm/K of the largest output area
Supply voltage (field)	24 VDC (-15 ... +30 %); via power jumper contacts (power supply via blade contact; transmission via spring contact)
Current consumption (5 V system supply)	61 mA
Data width	8 x 16-bit data; 8 x 8-bit control/status (optional)
Isolation	500 V system/field
Ambient temperature (operation)	0 ... +55 °C
Dimensions W x H x D	(12 x 100 x 69) mm
Approvals	CE, OrdLoc/HazLoc, ATEX/IECEx
For data sheet and additional information, see:	wago.com/750-597

Analog output ► Voltages and currents (configurable channel for channel)



750-564

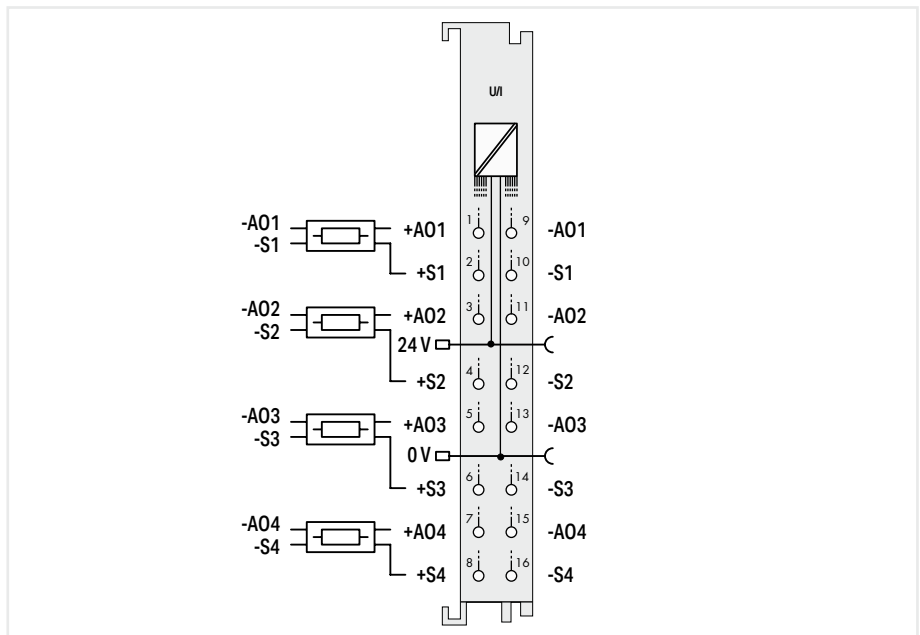

Item description	4-Channel Analog Output; Voltage/Current
Version	Standard with 16 connectors
Item no.	750-564
Order Text	4AO U/I
Technical data	
Number of analog outputs	4
Signal type	Voltage; Current
Signal type (current)	0 ... 10 mA; 2 ... 10 mA; -10 ... +10 mA; 0 ... 20 mA; 4 ... 20 mA; -20 ... +20 mA; 0 ... 22 mA; -22 ... +22 mA; 0 ... 12 mA; -12 ... +12 mA
Signal type (voltage)	0 ... 5 V; 1 ... 5 V; -5 ... +5 V; 0 ... 10 V; 2 ... 10 V; -10 ... +10 V; 0 ... 12 V; -12 ... +12 V
Actuator connection	4 x (2-wire); Voltage outputs can optionally be connected in 4-wire technology via the sense lines.
Load impedance (current output)	≤ 600 Ω
Load impedance (voltage output)	≥ 1 kΩ
Resolution [bit]	16 bits
Conversion time (typ.)	3 ms
Reference for measurement error	Voltage/current
Output error, reference temperature	25 °C
Output error, deviation (max.) of the upper-range value	0.05 %
Temperature coefficient	U: ±25 ppm/K of the upper-range value; I: ±50 ppm/K of the upper-range value
Supply voltage (field)	24 VDC (-25 ... +30 %); via power jumper contacts (power supply via blade contact; transmission via spring contact)
Current consumption (5 V system supply)	55 mA
Data width	4 x 16-bit data; 4 x 8-bit control/status (optional)
Isolation	500 V system/field
Ambient temperature (operation)	0 ... +55 °C
Dimensions W x H x D	(12 x 100 x 69) mm
Approvals	CE; Marine; OrdLoc/HazLoc; ATEX/IECEx
For data sheet and additional information, see:	wago.com/750-564

Function/Technology Modules



Housing Design (750 Series)

Dimensions W x H x D	Housing with 4 LEDs: 12 x 100 x 69.8 mm Housing with 8 LEDs: 12 x 100 x 67.8 mm
Depth from upper edge of DIN-rail	Housing with 4 LEDs: 62.6 mm Housing with 8 LEDs: 60.6 mm
Connection technology	CAGE CLAMP®
Conductor cross-section	0.08 ... 2.5 mm ² / 28 ... 14 AWG
Strip length	8 ... 9 mm / 0.33 inch

Housing Design (753 Series)

Dimensions W x H x D	Housing with 4 LEDs: 12 x 100 x 69.8 mm Housing with 8 LEDs: 12 x 100 x 69 mm
Depth from upper edge of DIN-rail	Housing with 4 LEDs: 62.6 mm Housing with 8 LEDs: 61.8 mm
Connection technology	CAGE CLAMP®
Conductor cross-section	0.08 ... 2.5 mm ² / 28 ... 14 AWG
Strip length	9 ... 10 mm / 0.37 inch

Housing Design (750 Series), Double Width

Dimensions W x H x D	24 x 100 x 69.8 mm
Depth from upper edge of DIN-rail	62.6 mm

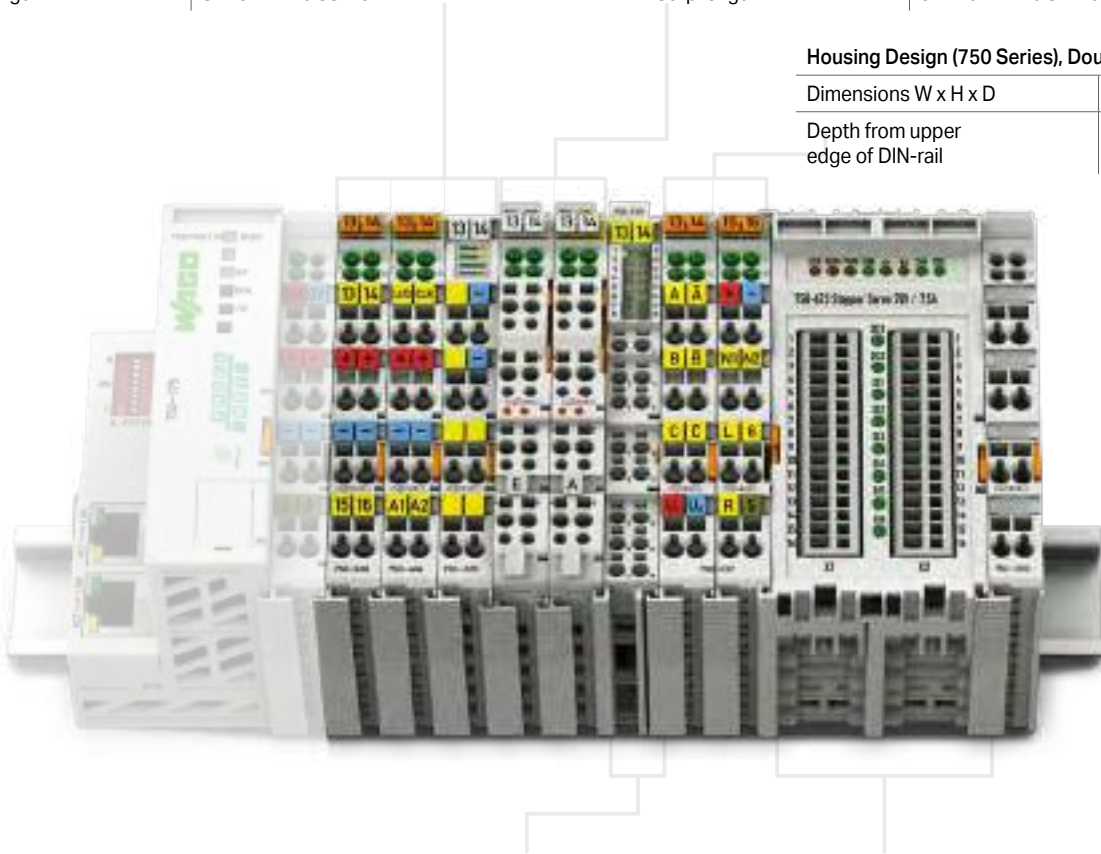

Housing Design (750 Series), with Push-in CAGE CLAMP® Connections (up to 16 connection points)

Dimensions W x H x D	12 x 100 x 69 mm
Depth from upper edge of DIN-rail	61.8 mm
Connection technology	Push-in CAGE CLAMP®
Conductor cross-section	Solid: 0.08 ... 1.5 mm ² / 28 ... 16 AWG Fine-stranded: 0.25 ... 1.5 mm ² / 22 ... 16 AWG
Strip length	8 ... 9 mm / 0.33 inch

Specialty Housing

Dimensions W x H x D	51 x 100 x 69.8 mm
Depth from upper edge of DIN-rail	62.6 mm
Connection technology	CAGE CLAMP®
Conductor cross-section	0.08 ... 1.5 mm ² / 28 ... 14 AWG
Strip length	5 ... 6 mm / 0.22 inch



I/O System -
750 XTR Series



I/O System – 750 and 753 Series, Function/Technology Modules

Contents

Function	Description	Item Number			Page
		Standard	Extended Temperature	Pluggable	
Counter	Up/Down Counter	750-404*		753-404	378
	Up Counter; Enable Input	750-404/000-001			378
	Peak-Time Counter	750-404/000-002			378
	Frequency Counter	750-404/000-003		753-404/000-003	379
	Up/Down Counter; Switch Output	750-404/000-004			378
	2 Up Counters; 16 Bits	750-404/000-005		753-404/000-005	380
	2 Up/Down Counters; 16 Bits; 500 Hz	750-638	750-638/025-000	753-638	381
Pulse Width Output	2 Pulse Width Outputs; 24 VDC; 0.1 A; 250 Hz	750-511		753-511	382
	2 Pulse Width Outputs; 24 VDC; 0.1 A; 2 kHz; Frequency Counter	750-511/000-001			382
	2 Pulse Width Outputs; 24 VDC; 0.1 A; 100 Hz	750-511/000-002			382
	4 Pulse Width Outputs; 24 VDC; 0.2 A; 20 kHz; Adjustable	750-677*			383
Distance and Angle Measurement	SSI Transmitter Interface; 24 Bits; 125 kHz; Gray Code	750-630			384
	SSI Transmitter Interface; 24 Bits; 125 kHz; Binary Code	750-630/000-001			385
	SSI Transmitter Interface; 24 Bits; 250 kHz; Binary Code	750-630/000-002			385
	SSI Transmitter Interface; 24 Bits; 125 kHz; Gray Code; Status Byte	750-630/000-004			384
	SSI Transmitter Interface; 15 Bits; 125 kHz; Gray Code; Status Byte	750-630/000-005			384
	SSI Transmitter Interface; 24 Bits; 250 kHz; Gray Code	750-630/000-006			384
	SSI Transmitter Interface; 25 Bits; 125 kHz; Gray Code	750-630/000-008			385
	SSI Transmitter Interface; 13 Bits; 250 kHz; Binary Code	750-630/000-009			385
	SSI Transmitter Interface; 25 Bits; 125 kHz; Binary Code	750-630/000-011			385
	SSI Transmitter Interface; 13 Bits; 125 kHz; Gray Code	750-630/000-012			385
	SSI Transmitter Interface; 29 Bits; 125 kHz; Binary Code	750-630/000-013			385
	SSI Transmitter Interface; Adjustable	750-630/003-000*			384
	Incremental Encoder Interface; RS-422; 16 Bits	750-631/000-004			387
	Incremental Encoder Interface; RS-422; 32 Bits	750-637*			387
	Incremental Encoder Interface; 24 VDC; Differential Input; 32 Bits	750-637/000-001*			386
	Incremental Encoder Interface; 24 VDC; Single-Ended; 32 Bits	750-637/000-002			386
	Incremental Encoder Interface; 5 VDC; 32 Bits; Single Evaluation	750-637/000-003			387
	Incremental Encoder Interface; 24 VDC; Single-Ended; 32 Bits; Cam Output	750-637/000-004			386
	Digital Impulse Interface	750-635		753-635	388
Vibration Monitoring	2-Channel Vibration Velocity/Bearing Condition Monitoring VIB I/O	750-645			389
Stepper Module	Stepper Controller; RS-422/24 VDC; 20 mA	750-670			390
	Stepper Controller; 24 VDC; 1.5 A	750-671			391
	Stepper Controller; 70 VDC; 7.5 A	750-672			392
	Servo Stepper Controller; 55 VDC; 7.5 A	750-673			393
DC Drive Controller	DC Drive Controller; 24 VDC; 5 A	750-636	750-636/025-000		394
	DC Drive Controller; 24 VDC; 5 A; Separate Motor Power Supply	750-636/000-700			394
	DC Drive Controller; 24 VDC; 5 A; Interference-Free	750-636/000-800			394
Proportional Valve Module	Proportional Valve Module	750-632			395
Ex i					See Section 7.9
*This module is also available as a variant of the 750 XTR Series.					See Section 8

Counter ▶ Up/down counter



750-404

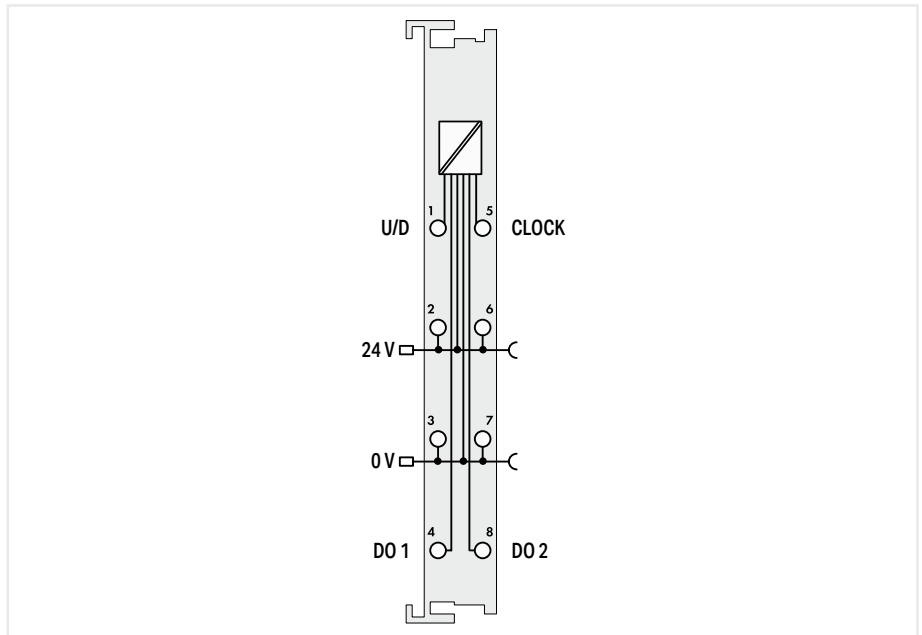

Item description	Up/Down Counter				
Version	Standard	pluggable (delivery without connector)	Switch output	Enable input	Peak-time counter
Item no.	750-404	753-404	750-404/000-004	750-404/000-001	750-404/000-002
Order Text	Up/Down Counter	Up/Down Counter	Up/Down Counter; Switch Output	Up Counter; Release Input	Peak Time Counter

Technical data					
Pluggable connector	-	pluggable	-		
Number of digital outputs			2		
Number of counters			1		
Output current per channel			0.5 A		
Output current			short-circuit-protected		
Voltage range for signal (0)			-3 ... +5 VDC		
Voltage range for signal (1)			15 ... 30 VDC		
Input current (typ.)			6 mA		
Switching frequency (max.)			100 kHz	10 kHz	
Counter depth			32 bits		
Supply voltage (field)	24 VDC (-15 ... +20 %); via power jumper contacts (power supply via blade contact; transmission via spring contact)				
Current consumption (5 V system supply)	70 mA				
Data width	32-bit data; 8-bit control/status				
Isolation	500 V system/field				
Ambient temperature (operation)	0 ... +55 °C				
Dimensions W x H x D	(12 x 100 x 69.8) mm				
Approvals	CE; Marine; OrdLoc/HazLoc; ATEX/IECEx				

For data sheet and additional information, see: wago.com/750-404 | wago.com/753-404 | wago.com/750-404/000-004

Accessories	Item no.	Item no.	Item no.	Item no.	Item no.
Plug	-	753-110	-	-	-
Up/down counter: When the U/D input is switched with +24 V, the counting direction is upward. When an input is not switched or is 0 V, the counting direction is downward.		Up counter: The counting is locked when the GATE input is open or 0 V is present. Counting is enabled with +24 V at the GATE input.		Peak-time counter: The count pulses at the CLOCK input are recorded over a pre-set period of 10 seconds.	

Counter ▶ Frequency counter



750-404/000-003

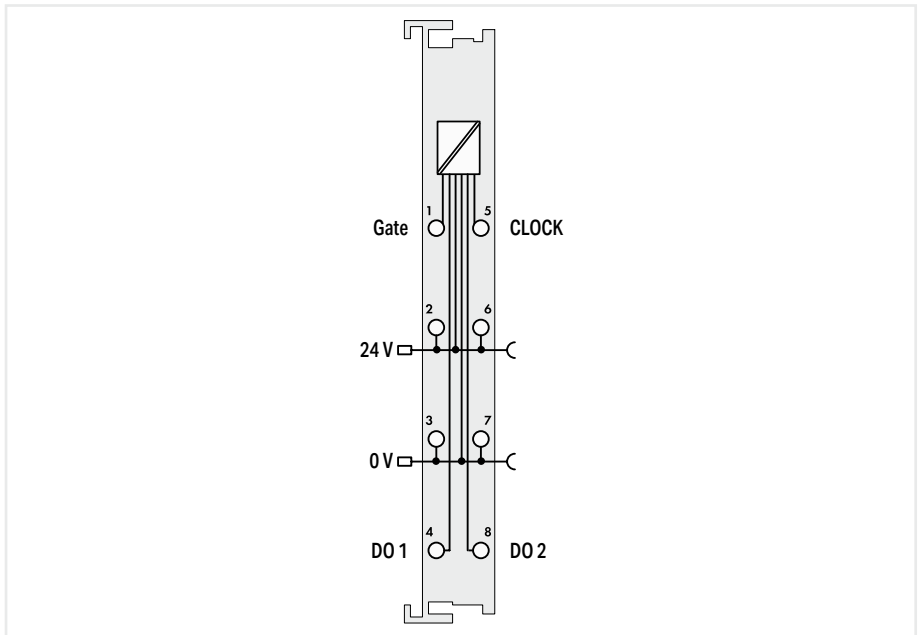

Item description	Frequency Counter	
Version	Standard	pluggable (delivery without connector)
Item no.	750-404/000-003	753-404/000-003
Order Text	Frequency Counter	Frequency Counter; 100kHz
Technical data		
Pluggable connector	-	pluggable
Number of digital outputs	2	
Number of counters	1	
Output current per channel	0.5 A	
Output current	short-circuit-protected	
Voltage range for signal (0)	-3 ... +5 VDC	
Voltage range for signal (1)	15 ... 30 VDC	
Input current (typ.)	5 mA	
Switching frequency (max.)	100 kHz	
Counter depth	32 bits	
Supply voltage (field)	24 VDC (-15 ... +20 %); via power jumper contacts (power supply via blade contact; transmission via spring contact)	
Current consumption (5 V system supply)	70 mA	
Data width	32-bit data; 8-bit control/status	
Isolation	500 V system/field	
Ambient temperature (operation)	0 ... +55 °C	
Dimensions W x H x D	(12 x 100 x 69.8) mm	
Approvals		
For data sheet and additional information, see:	wago.com/750-404/000-003	wago.com/753-404/000-003
Accessories	Item no.	Item no.
Plug	-	753-110

The frequency counter measures the 24 V signal pulse period at the CLOCK input and converts it to a frequency value. The measurement is enabled when the GATE input is open or 0 V is present. Measurement is disabled when 24 V are present at the GATE input.

Counter ▶ 2 up counters



750-404/000-005

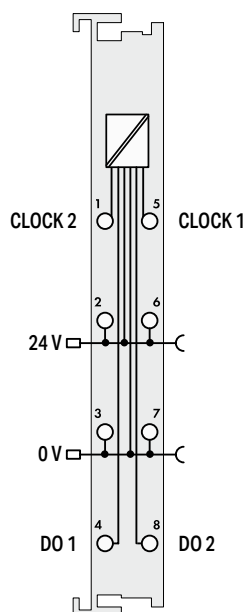

Item description	2 Up Counters; 16 bits	
Version	Standard	pluggable (delivery without connector)
Item no.	750-404/000-005	753-404/000-005
Order Text	2Up Counter; 16bits	2Up Counter; 16bits
Technical data		
Pluggable connector	-	pluggable
Number of digital outputs		2
Number of counters		2
Output current per channel		0.5 A
Output current		short-circuit-protected
Voltage range for signal (0)		-3 ... +5 VDC
Voltage range for signal (1)		15 ... 30 VDC
Input current (typ.)		5 mA
Switching frequency (max.)		5 kHz
Counter depth		16 bits
Supply voltage (field)	24 VDC (-15 ... +20 %); via power jumper contacts (power supply via blade contact; transmission via spring contact)	
Current consumption (5 V system supply)		70 mA
Data width	32-bit data; 8-bit control/status	
Isolation	500 V system/field	
Ambient temperature (operation)	0 ... +55 °C	
Dimensions W x H x D	(12 x 100 x 69.8) mm	
Approvals	CE; Marine; OrdLoc/HazLoc; ATEX/IECEX	
For data sheet and additional information, see:	wago.com/750-404/000-005	wago.com/753-404/000-005
Accessories	Item no.	Item no.
Plug	-	753-110

This module features two 16-bit up counters. The count pulses are recorded at the CLOCK 1 and CLOCK 2 inputs.

Counter ▶ 2 up/down counters



750-638

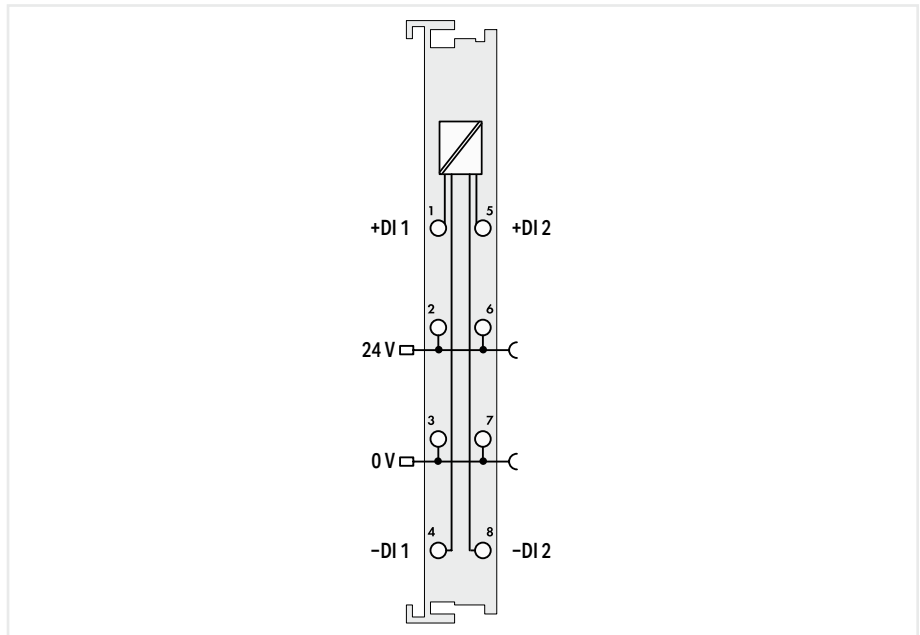

Item description	2 Up/Down Counters; 16 bits; 500 Hz		
Version	Standard	ext. temperature	pluggable (delivery without connector)
Item no.	750-638	750-638/025-000	753-638
Order Text	2Up/Down Counter; 16bits; 500Hz	2Up/Down Counter; 500Hz; T	2Up/Down Counter; 16bits; 500Hz
Technical data			
Pluggable connector	-		pluggable
Number of counters	2		
Voltage range for signal (0)	-3 ... +5 VDC (per EN 61131 Type 1)		
Voltage range for signal (1)	15 ... 30 VDC (per EN 61131 Type 1)		
Switching frequency (max.)	500 Hz		
Minimum pulse width (0, 1)	1 ms		
Counter depth	16 bits		
Supply voltage (field)	24 VDC (-15 ... +20 %); via power jumper contacts (power supply via blade contact; transmission via spring contact)		
Current consumption (5 V system supply)	10 mA		
Data width	2 x 16-bit data; 2 x 8-bit control/status		
Isolation	500 V system/field		
Ambient temperature (operation)	0 ... +55 °C	-20 ... +60 °C	0 ... +55 °C
Dimensions W x H x D	(12 x 100 x 69.8) mm		
Approvals	CE, OrdLoc/HazLoc; ATEX/IECEx		
For data sheet and additional information, see:	wago.com/750-638		wago.com/753-638
Accessories	Item no.	Item no.	Item no.
Plug	-	-	753-110

Pulse width output



750-511

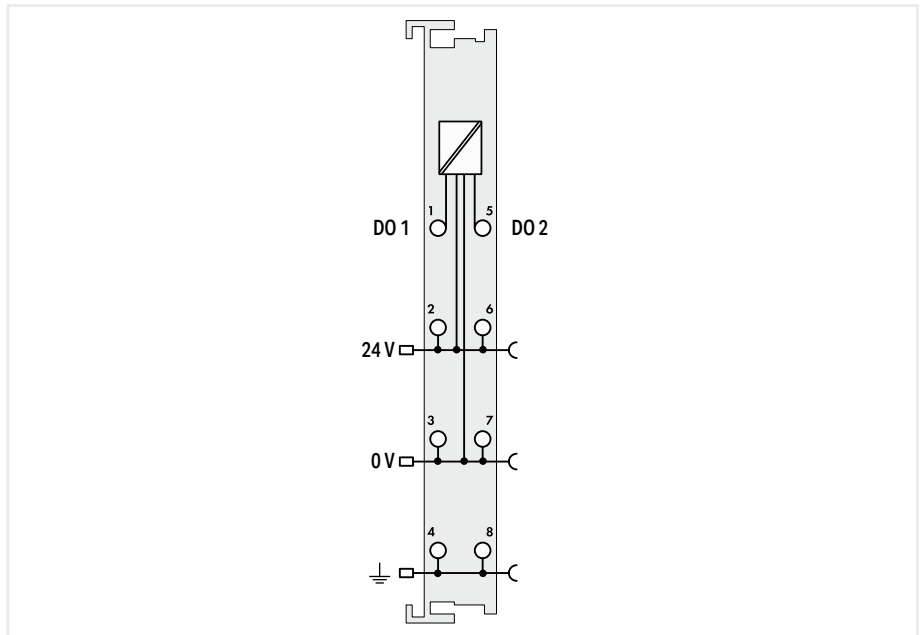

Item description	2 Pulse Width Outputs; 24 VDC; 0.1 A; 250 Hz			
Version	Standard	pluggable (delivery without connector)	2 kHz; Frequency counter	100 Hz
Item no.	750-511	753-511	750-511/000-001	750-511/000-002
Order Text	2PWM; 24 VDC; 0.1A; 250kHz	2PWM; 24 VDC; 0.1A; 250Hz	2PWM; 24 VDC; 0.1A; 2kHz; Frequency Counter	2PWM; 24 VDC; 0.1A; 100Hz

Technical data				
Pluggable connector	-	pluggable	-	
Number of digital outputs	2			
Load type	Resistive, inductive			
Pulse frequency	250 Hz	2 Hz ... 2 kHz	100 Hz	
Duty cycle	0 ... 100 %	50 %	0 ... 100 %	
Output current per channel	0.1 A			
Output current	short-circuit-protected			
Switching frequency (max.)	-			
Resolution [bit]	10 bits			
Supply voltage (field)	24 VDC (-15 ... +20 %); via power jumper contacts (power supply via blade contact; transmission via spring contact)			
Current consumption (5 V system supply)	70 mA			
Data width	2 x 16-bit data; 2 x 8-bit control/status			
Operating mode	-			
Isolation	500 V system/field			
Ambient temperature (operation)	0 ... +55 °C			
Dimensions W x H x D	(12 x 100 x 69.8) mm			
Approvals	CE; OrdLoc/HazLoc; ATEX/IECEx			
Approvals (pending)	-			
For data sheet and additional information, see:	wago.com/750-511	wago.com/753-511	wago.com/750-511/000-001	
Accessories	Item no.	Item no.	Item no.	Item no.
Plug	-	753-110	-	-

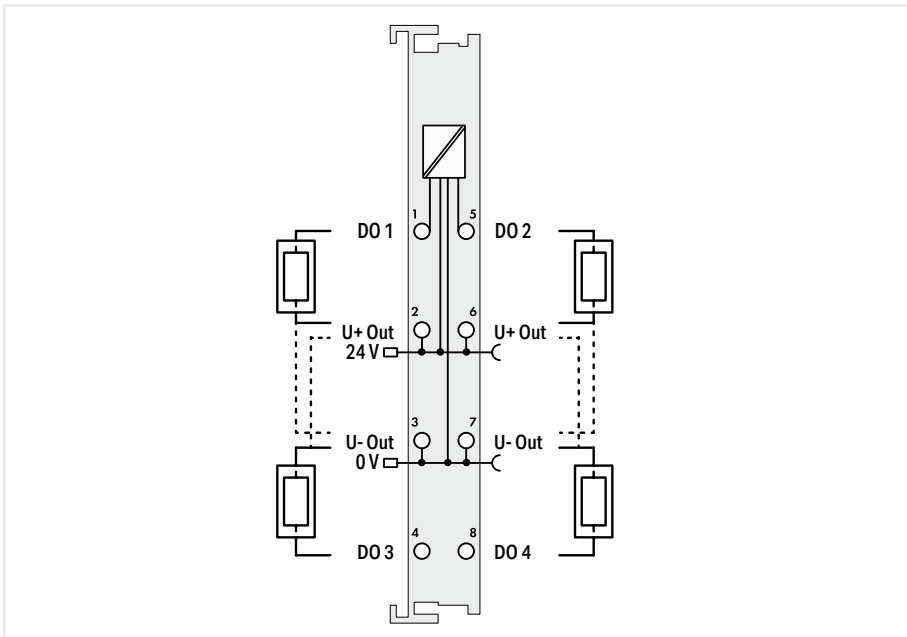

4-Channel Pulse Width Outputs; 24 VDC; 0.2 A; 20 kHz
Standard
750-677
4PWM; 24 VDC; 0.2A; 20kHz

-
4
-
0 ... 20,000 Hz; integer
0 ... 100 %; 11-bit resolution
0.2 A
short-circuit-protected; 0.4 A, short-circuit-protected in bridge mode
20 kHz
-
24 VDC (-25 ... +30 %); via power jumper contacts (power supply via blade contact; transmission via spring contact)
85 mA
4 x 16-bit data; 4 x 8-bit control/status
1: PWM DC (variable duty cycle); 2: PWM Frq (variable frequency); 3: PWM Frq - Cnt; 4: Pulse Frq - Cnt; 5: PWM Pulse - Dir
500 V system/field
0 ... +55 °C
(12 x 100 x 67.8) mm
CE
Marine; OrdLoc/HazLoc
wago.com/750-677

Item no.
-

This module outputs separately adjustable PWM signals at four channels. The channels can be individually configured as LSS (low-side switching) or HSS (high-side switching) and are short-circuit protected. The PWM signals are each 16 bits wide.

The module supports five operating modes. In both "PWM DC" and "PWM Frq" operating modes, all four channels may be used independently. The bridge mode can also be activated if the same operating mode is set on each channel pair (1 and 2 or 3 and 4). Both channels work synchronously and can be connected in parallel. In the other three complex operating modes, two channels functionally correlate with each other.

The first channel outputs the PWM signal and the second channel a static signal ("0" or "1").

Refer to the manual ("Operating Modes" section) for all setting options and the bit signification in the process image.

The "PWM DC" operating mode is set by default.

Distance and angle measurement ► SSI transmitter interface



750-630/003-000

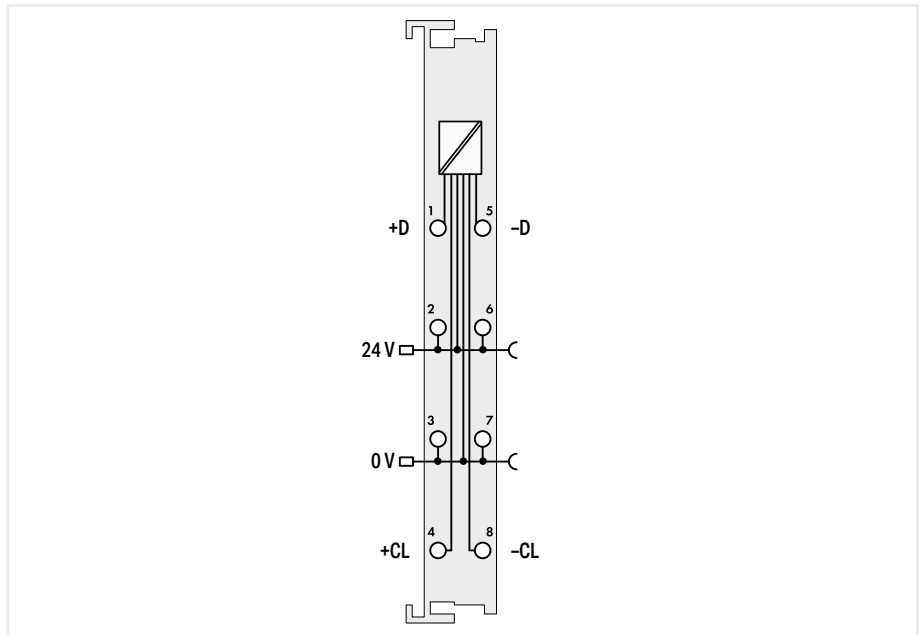

Item description		SSI Transmitter Interface			
Version	adjustable	24 bits; 125 kHz; gray code	24 bits; 125 kHz; gray code; status byte	15 bits; 125 kHz; gray code; status byte	24 bits; 250 kHz; gray code
Item no.	750-630/003-000	750-630	750-630/000-004	750-630/000-005	750-630/000-006
Order Text	SSI Interface; adjust	SSI Interface; 24bits; 125kHz; Gray	SSI Interface; 24bits; 125kHz; Gray; Status	SSI Interface; 15bits; 125kHz; Gray; Status	SSI Interface; 24bits; 250kHz; Gray
Technical data					
Encoder connection	On + D, -D / Off + CI, - CI				
Supply voltage (encoder)	24 VDC; via power jumper contacts				
Data transmission rate	250 kHz	125 kHz		250 kHz	
Serial input	Data width: 1 ... 32 bits	Data width: 24 bits		Data width: 15 bits	Data width: 24 bits
Code	Gray code/binary code	Gray code			
Supply voltage (field)	24 VDC (-15 ... +20 %); via power jumper contacts (power supply via blade contact; transmission via spring contact)				
Current consumption (5 V system supply)	20 mA				
Data width	1 x 32 bits	1 x 32-bit; 1 x 8-bit control/status (optional)			1 x 32 bits
Isolation	500 V system/field				
Ambient temperature (operation)	0 ... +55 °C				
Dimensions W x H x D	(12 x 100 x 69.8) mm				
Approvals	CE; Marine; OrdLoc/HazLoc; ATEX/IECEx				
For data sheet and additional information, see:	wago.com/750-630/003-000				

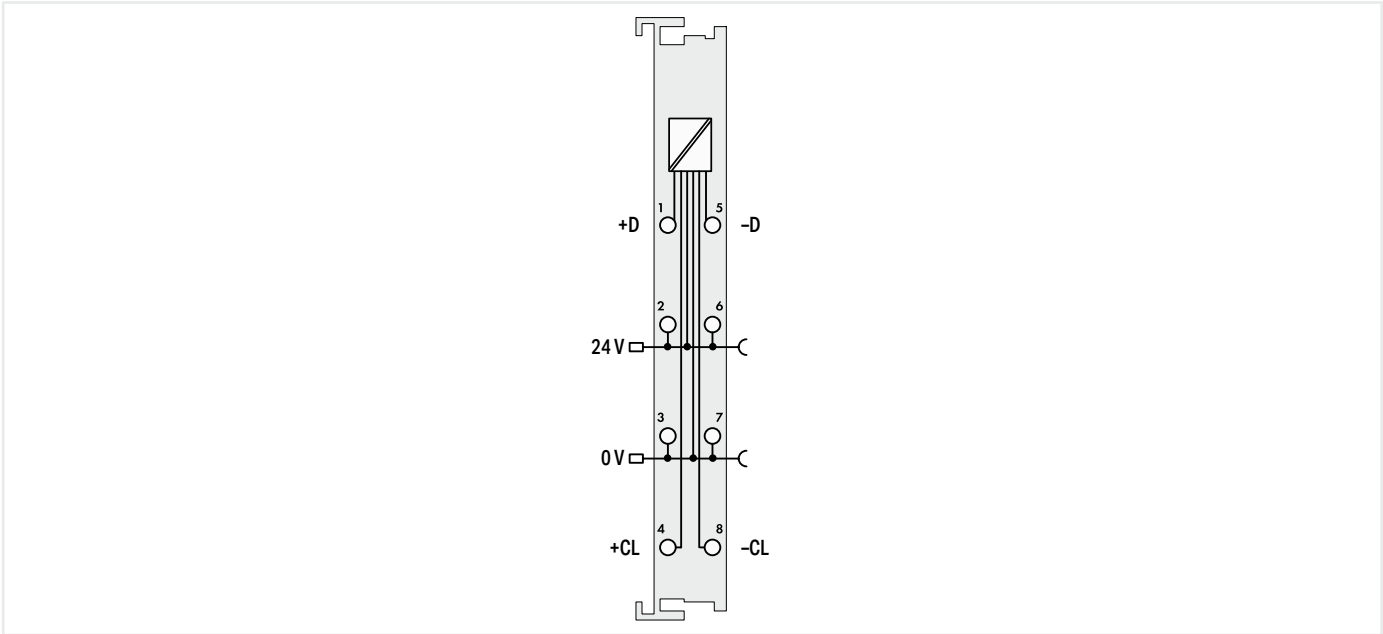

SSI Transmitter Interface

25 bits; 125 kHz; gray code	13 bits; 125 kHz; gray code	24 bits; 125 kHz; bin. code	25 bits; 125 kHz; bin. code	29 bits; 125 kHz; bin. code	24 bits; 250 kHz; bin. code	13 bits; 250 kHz; bin. code
750-630/000-008	750-630/000-012	750-630/000-001	750-630/000-011	750-630/000-013	750-630/000-002	750-630/000-009
SSI Interface; 25bits; 125kHz; Gray	SSI Interface; 13bits; 125kHz; Gray	SSI Interface; 24bits; 125kHz; Bin	SSI Interface; 25bits; 125kHz; Bin	SSI Interface; 29bits; 125kHz; Bin	SSI Interface; 24bits; 250kHz; Bin	SSI Interface; 13bits; 250kHz; Bin

On + D, -D / Off + CL, - CL						
24 VDC; via power jumper contacts						
125 kHz			250 kHz			
Data width: 25 bits	Data width: 13 bits	Data width: 24 bits	Data width: 25 bits	Data width: 29 bits	Data width: 24 bits	Data width: 13 bits
Gray code		Binary code				
24 VDC (-15 ... +20 %); via power jumper contacts (power supply via blade contact; transmission via spring contact)						
20 mA						
1 x 32 bits						
500 V system/field						
0 ... +55 °C						
(12 x 100 x 69.8) mm						
CE, Marine; OrdLoc/HazLoc; ATEX/IECEX wago.com/750-630/003-000						

Distance and angle measurement ► Incremental encoder interface



750-637/000-001

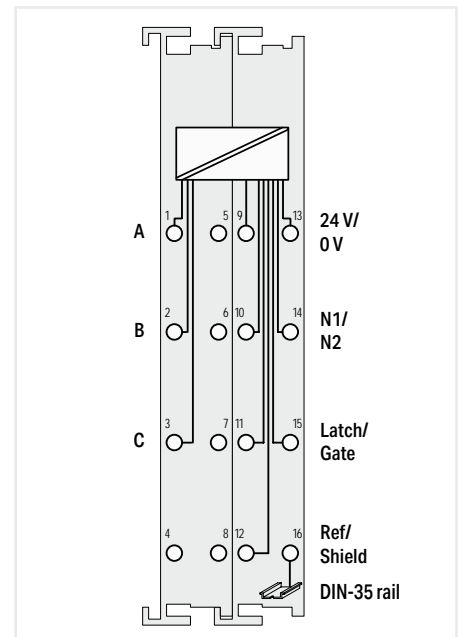
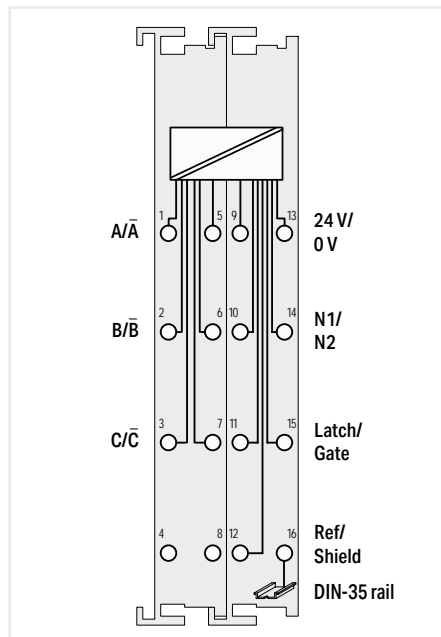

Item description	Incremental Encoder Interface; 24 VDC; Differential input; 32 bits		Incremental Encoder Interface; 24 VDC; Single-ended; 32 bits	
Version	Standard		Standard	Cam output
Item no.	750-637/000-001		750-637/000-002	750-637/000-004
Order Text	Inc. Encoder; 24 VDC; Diff; 32bits		Inc. Encoder; 24 VDC; SE; 32bits	Inc. Encoder; 24 VDC; SE; 32bits; Cam
Technical data				
Encoder connection	A; /A; B; /B; C; /C (differential inputs)		A; B; C (single-ended inputs)	
Counter depth	32 bits		32 bits	
Limit frequency	250 kHz		250 kHz	
Quadrature decoder	4x evaluation		4x evaluation	
Zero impulse (latch)	32 bits		32 bits	
Commands	Reading, setting, activating		Reading, setting, activating	
Supply voltage (encoder)	24 VDC		24 VDC	
Supply current (encoder) max.	300 mA		300 mA	
Output voltage	24 VDC		24 VDC	
Output current per channel	0.5 A		0.5 A	
Output current	short-circuit-protected		short-circuit-protected	
Voltage range for signal (0)	$(U_{ABC} - U_{ABC/}): -30 \dots +15 \text{ VDC}; \text{Latch, gate, ref.: } -3 \dots +5 \text{ VDC}$		$-3 \dots +5 \text{ VDC}$	
Voltage range for signal (1)	$(U_{ABC} - U_{ABC/}): 15 \dots 30 \text{ VDC}; \text{Latch, gate, ref.: } 15 \dots 30 \text{ VDC}$		15 ... 30 VDC	
Input current (typ.)	Latch 5 mA, Gate 7 mA, Ref. 7 mA		Latch 5 mA, Gate 7 mA, Ref. 7 mA	
Current consumption, field supply (module with no external load)	35 mA		35 mA	
Current consumption (5 V system supply)	110 mA		110 mA	
Data width	1 x 32-bit data 2 x 8-bit control/status		1 x 32-bit data 2 x 8-bit control/status	
Isolation	500 V system/field		500 V system/field	
Ambient temperature (operation)	0 ... +55 °C		0 ... +55 °C	
Dimensions W x H x D	(24 x 100 x 69.8) mm		(24 x 100 x 69.8) mm	
Approvals	CE; Marine; OrdLoc/HazLoc; ATEX/IECEx		CE; Marine; OrdLoc/HazLoc; ATEX/IECEx	
For data sheet and additional information, see:	wago.com/750-637/000-001		wago.com/750-637/000-001	

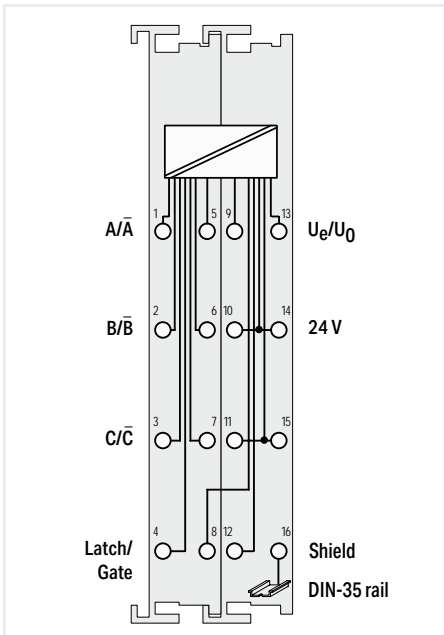

Incremental Encoder Interface; RS-422; 16 bits	
Standard	
750-631/000-004	
Inc. Encoder; RS422	

A; /A; B; /B; C; /C (RS-422 inputs)
16 bits
1000 kHz
4x evaluation
16 bits
Reading, setting, activating
5 VDC
200 mA
-
-
-
$U_{ABC} = 0\text{ V}$, $U_{ABC/} = 5\text{ V}$; Latch, gate $\leq 5.0\text{ V}$; External error $U \geq 5.0\text{ V}$ or open input
[ERROR READING XHTML FRAGMENT]
-
10 mA
50 mA
2-byte output; 5-byte input; 2x 8-bit control/status (optional); 3 additional output bytes (reserved)
500 V system/field
0 ... +55 °C
(24 x 100 x 69.8) mm
CE; Marine; OrdLoc/HazLoc
wago.com/750-631/000-004

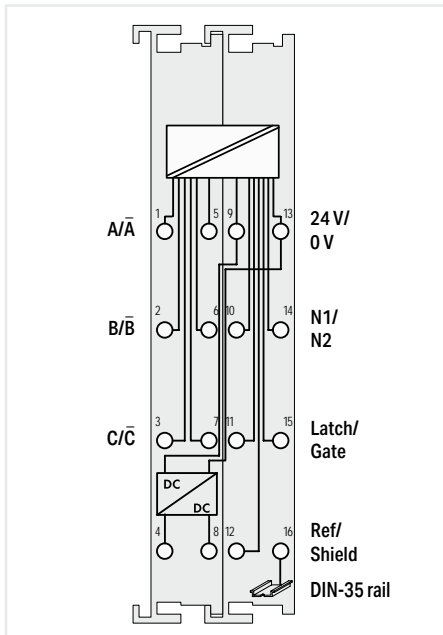

Incremental Encoder Interface; RS-422; 32 bits	
Standard	Single evaluation
750-637	750-637/000-003
Inc. Encoder; RS422; 32bits	Inc. Encoder; RS422; 32bits; Single Interp.

A; /A; B; /B; C; /C (RS-422 inputs)	
32 bits	
250 kHz	
4x evaluation	1x report
32 bits	
Reading, setting, activating	
5 VDC	
300 mA	
24 VDC	
0.5 A	
short-circuit-protected	
$U_{ABC} = \text{RS-422}$; Latch, gate, ref.: -3 ... +5 VDC	
$U_{ABC} = \text{RS-422}$; Latch, gate, ref.: 15 ... 30 VDC	
Latch 5 mA, Gate 7 mA, Ref. 7 mA	
35 mA	
110 mA	
1 x 32-bit data 2 x 8-bit control/status	
500 V system/field	
0 ... +55 °C	
(24 x 100 x 69.8) mm	
CE; Marine; OrdLoc/HazLoc; ATEX/IECEx	
wago.com/750-637	

Distance and angle measurement ► Digital impulse interface



750-635

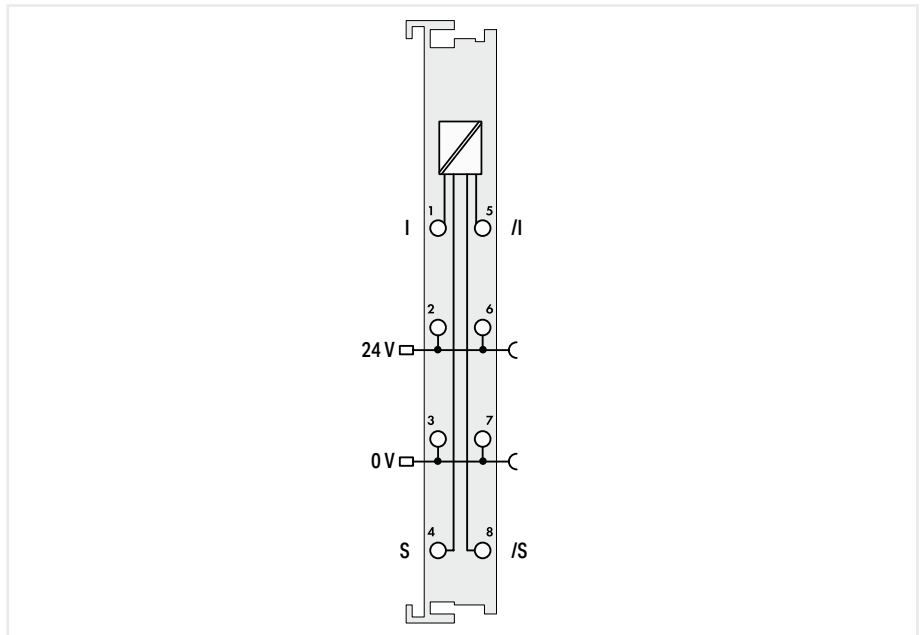

Item description		Digital Impulse Interface	
Version		Standard	pluggable (delivery without connector)
Item no.	750-635	750-635	753-635
Order Text		Digital Impulse Interface	Digital Impulse Interface
Technical data			
Pluggable connector		-	pluggable
Encoder connection		Start/stop; initialization; Uv; ground; shield connection via encoder housing	
Number of inputs		1	
Resolution		1 µm	
Update time (update rate)		2 ms	
Position sensor length		4 m	
Connection requirement (permissible cable type)		RS-422	
Connection requirement (permissible cable length)		500 m	
Supply voltage (field)		24 VDC (-15 ... +20 %); via power jumper contacts (power supply via blade contact; transmission via spring contact)	
Current consumption (5 V system supply)		45 mA	
Data width		1 x 24-bit data 1 x 8-bit control/status	
Isolation		500 V system/field	
Ambient temperature (operation)		0 ... +55 °C	
Dimensions W x H x D		(12 x 100 x 69.8) mm	
Approvals		CE; Ⓢ- OrdLoc/HazLoc; Ⓢ ATEX/IECEx	
For data sheet and additional information, see:		wago.com/750-635	wago.com/753-635
Accessories		Item no.	Item no.
Plug		-	753-110

This digital impulse interface connects position sensors equipped with a start/stop interface. After receiving a read pulse, these sensors deliver a time-delayed reply impulse. The time delay is proportional to the sensor distance. Each sensor may have up to four position transmitters (permanent magnets). Their position data can be accessed serially by the controller and are stored in the process image of the fieldbus coupler as a 24-bit value. Position sensors with the following features can be used:

- Start/stop interface with RS-422 differential signals
- 24 V sensor supply

Manufacturer, e.g., Balluff

Vibration monitoring



750-645

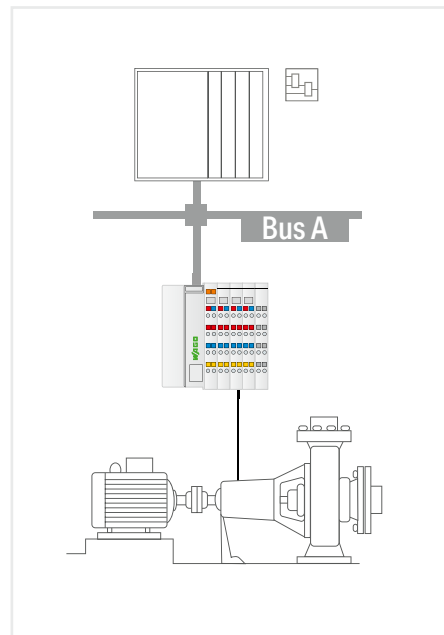
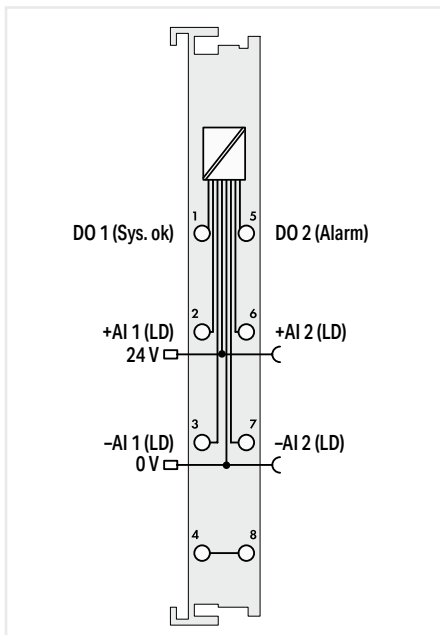

Item description	2-Channel Vibration Velocity/Bearing Condition Monitoring VIB I/O Module
Version	Standard
Item no.	750-645
Order Text	2VIB VRMS/SPM Multi
Technical data	
Encoder connection	+AI1, -AI1, +AI2, -AI2
Number of inputs	2
Number of digital outputs	2
Output voltage	24 VDC
Output current per channel	0.5 A
Output current	short-circuit-protected
Device-specific	Both alarm and warning threshold can be set via process image and engineering software.
Oscillating velocity (RMS)	0 ... 100 mm/s
Shock impulse (SPM)	-10 ... +80 db _{SV}
Supply voltage (field)	24 VDC (-15 ... +20 %); via power jumper contacts (power supply via blade contact; transmission via spring contact)
Current consumption (5 V system supply)	30 mA
Isolation	500 V system/field
Ambient temperature (operation)	0 ... +55 °C
Dimensions W x H x D	(12 x 100 x 67.8) mm
Approvals	CE, OrdLoc/HazLoc; ATEX/IECEX
For data sheet and additional information, see:	wago.com/750-645

This module is used for online monitoring of machine vibration levels. It records the two most important parameters required for status monitoring: vibration severity and roller bearing condition.

Vibration velocity is a measurement for machines' energy and therefore, a suitable indicator for the vibration forces acting on the machine.

Roller bearing condition is evaluated on the basis of high-frequency shock impulse signals. Shock impulses are momentary impulses arising from mechanical damage to roller bearings or the bearing surfaces.

By recording the measurement results and evaluation in a trend curve, bearing damage can be detected at an early stage. A special Tandem-Piezo® acceleration sensor serves as encoder to facilitate simultaneous measurement of machine vibrations and high-frequency shock impulse signals.

Stepper module ▶ Stepper controller



750-670

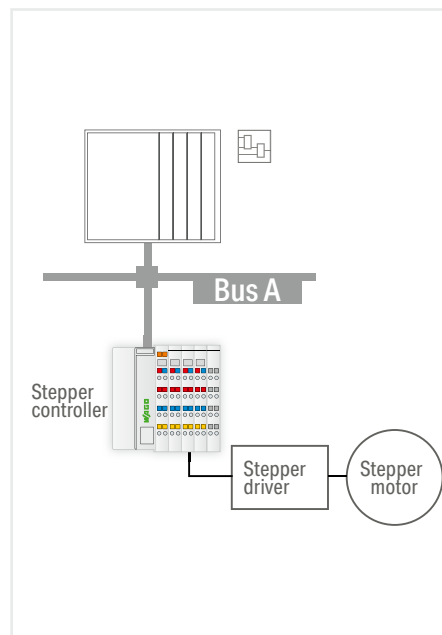
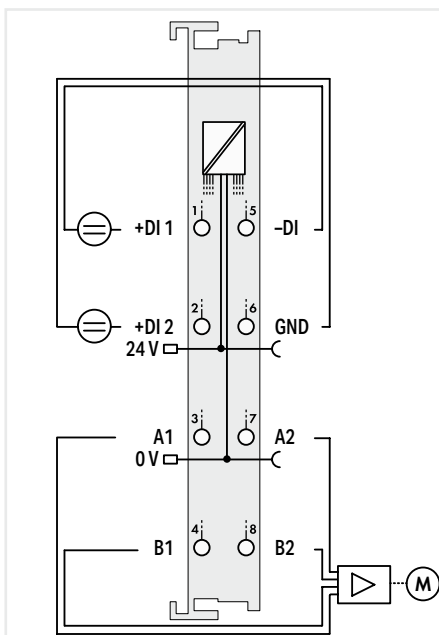

Item description	Stepper Controller; RS-422/24 VDC; 20 mA
Version	Standard
Item no.	750-670
Order Text	Stepper Controller; RS422/24 VDC; 20mA
Technical data	
Number of outputs	1 channel (2 differential outputs A1, A2, B1, B2)
Signal voltage	5 VDC (internal), 5 ... 24 VDC (external)
Resolution	15 bits + 16 bit prescaler
Stepper resolution	23 bits + sign bit
Load type	RS-422, TTL, optocoupler
Output current per channel	0.03 A
Output current	short-circuit-protected
Number of digital inputs	2
Voltage range for signal (0)	-3 ... +5 VDC
Voltage range for signal (1)	15 ... 30 VDC
Input filter	100 µs, software filter can be connected
Supply voltage (field)	24 VDC (-25 ... +30 %); via power jumper contacts (power supply via blade contact; transmission via spring contact)
Current consumption (5 V system supply)	98 mA
Data width	12-byte input/output
Isolation	500 V system/field
Ambient temperature (operation)	0 ... +55 °C
Dimensions W x H x D	(12 x 100 x 67.8) mm
Approvals	CE, OrdLoc/HazLoc, ATEX/IECEX
For data sheet and additional information, see:	wago.com/750-670

This stepper controller is used to control different drive power sections with pulse/direction interface or incremental encoder input.

The 64 times microstepping prevents step losses due to resonance in the acceleration phases and reduces wear on the mechanical parts. Adjustable current limits for stop, acceleration and constant speed help minimize motor power dissipation. Two configurable inputs for start/stop, limit switches, reference cams, jog/tip, etc., are directly processed by the internal software without delay.

Versatile functions, such as positioning with different acceleration ramps, command tables, cam switch, auto referencing and other event-dependent properties provide this controller with a wide spectrum of possible uses.

Operating modes:

- Step positioning
- Reference motion
- Jog
- Tip
- Command table
- Cam switch

Functions include:

- Absolute/relative positioning
- Setpoint change on the fly
- Rotary axis

Additional operating modes:

- Pulse width modulation
- Frequency generator
- Single-shot mode

Stepper module ▶ Stepper controller



750-671

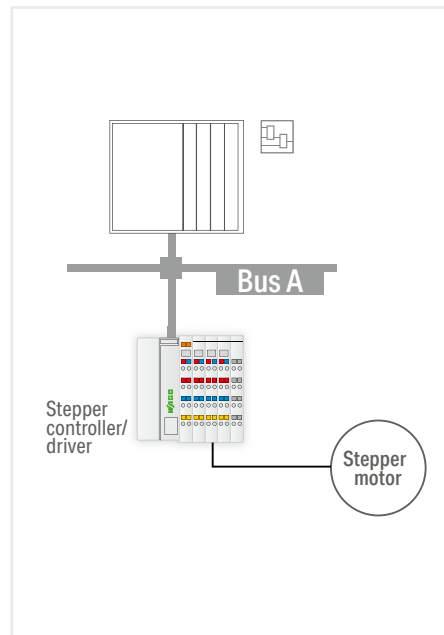
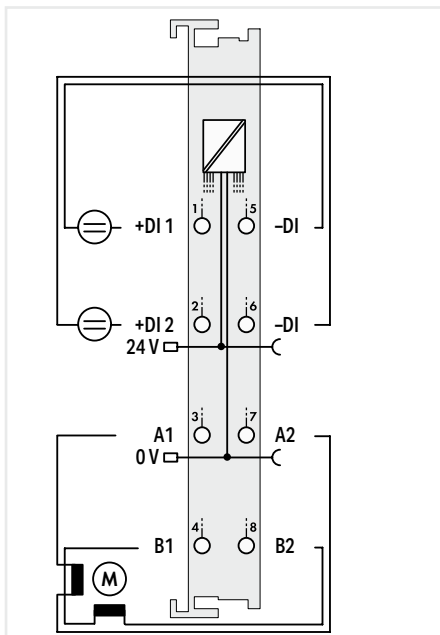

Item description	Stepper Controller; 24 VDC; 1.5 A
Version	Standard
Item no.	750-671
Order Text	Stepper Controller; 24 VDC; 1.5A
Technical data	
Number of outputs	1 stepper motor (2 phases/bipolar)
Output current (max.) (motor)	Up to 2 x 1.5 A peak value; 1 A rms
Stepper frequency (full-step) max.	7812 Hz
Resolution	15 bits + 16 bit prescaler
Stepper resolution	23 bits + sign bit
Number of digital inputs	2
Voltage range for signal (0)	-3 ... +5 VDC
Voltage range for signal (1)	15 ... 30 VDC
Input filter	100 µs, software filter can be connected
Supply voltage (field)	24 VDC (-25 ... +30 %); via power jumper contacts (power supply via blade contact; transmission via spring contact)
Current consumption (5 V system supply)	85 mA
Data width	12-byte input/output
Isolation	500 V system/field
Ambient temperature (operation)	0 ... +55 °C
Dimensions W x H x D	(12 x 100 x 67.8) mm
Approvals	CE; ATEX/IECEX
For data sheet and additional information, see:	wago.com/750-671

This stepper controller has an on-board power driver designed to control 2-phase stepper motors up to 24 V/1.5 A.

The 64 times microstepping prevents step losses due to resonance in the acceleration phases and reduces wear on the mechanical parts. Adjustable current limits for stop, acceleration and constant speed help minimize motor power dissipation. Two configurable inputs for start/stop, limit switches, reference cams, jog/tip, etc., are directly processed by the internal software without delay.

Versatile functions, such as positioning with different acceleration ramps, command tables, cam switch, auto referencing and other event-dependent properties provide this controller with a wide spectrum of possible uses.

Operating modes:

- Step positioning
- Reference motion
- Jog
- Tip
- Command table
- Cam switch

Functions include:

- Absolute/relative positioning
- Setpoint change on the fly
- Rotary axis

Stepper module ▶ Stepper controller



750-672

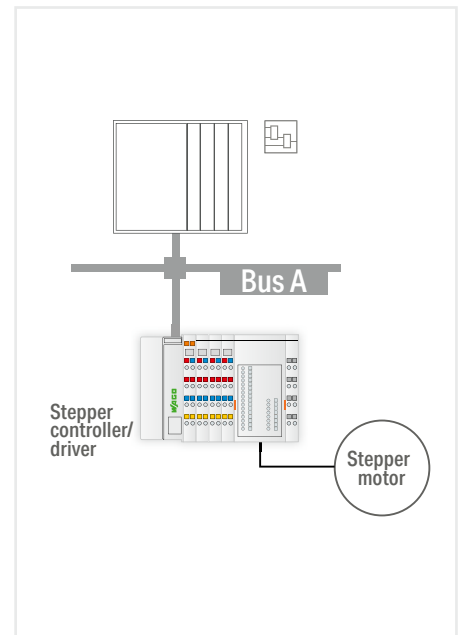
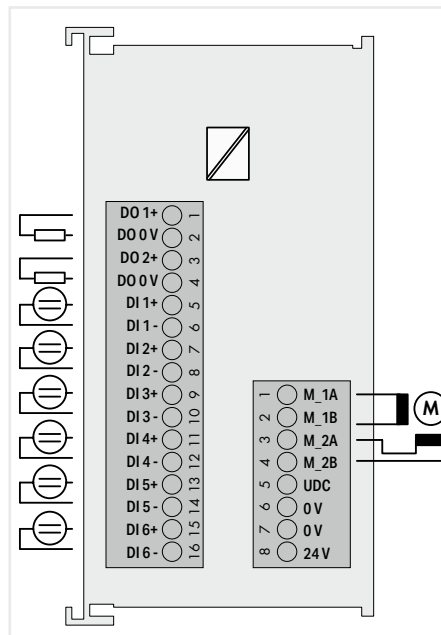

Item description	Stepper Controller; 70 VDC; 7.5 A
Version	Standard
Item no.	750-672
Order Text	Stepper Controller; 70 VDC; 7.5A
Technical data	
Number of motor outputs	1 stepper motor (2 phases)
Supply voltage (motor)	55 VDC; Absolute upper limit: 71.5 V; Absolute lower limit: 18 V
Output current (max.) (motor)	2 x 5.0 A (2 x 7.5 A transient)
Stepper frequency (full-step) max.	7812 Hz
Resolution	15 bits + 16 bit prescaler; 64 microsteps per full step
Stepper resolution	23 bits + sign bit
Load type	Resistive load, inductive load (max. 2 H), lamps
Number of digital outputs	2
Output voltage	Control voltage: 24 VDC (-25 % ... +30 %); Closed current: 120 mA + 2 x 0.5 A (DO1, DO2, load-dependent); Motor voltage: 55 VDC nominal value; Absolute upper limit: 71.5 V; Absolute lower limit: 18 V; Closed current (typ.) = 5 mA; Protection via external fuse 5 A
Output current per channel	0.5 A
Output current	short-circuit-protected
Switching frequency (max.)	5 Hz; Inductive load per IEC 947-5-1, DC 13
Voltage range for signal (0)	-3 ... +5 VDC
Voltage range for signal (1)	15 ... 30 VDC
Input filter	100 µs, software filter can be connected
Current consumption (5 V system supply)	70 mA
Data width	12-byte input/output
Isolation	500 V system/field
Ambient temperature (operation)	0 ... +55 °C
Dimensions W x H x D	(48 x 100 x 69.8) mm
Approvals	CE; UL 61800-5-1
For data sheet and additional information, see:	wago.com/750-672

This stepper controller has an on-board power driver designed to control 2-phase stepper motors.

The 64 times microstepping prevents step losses due to resonance in the acceleration phases and reduces wear on the mechanical parts. Adjustable current limits for stop, acceleration and constant speed help minimize motor power dissipation.

Six configurable inputs are directly processed by the internal software without delay. Two outputs can be linked with internal functions or freely allocated. Versatile functions enable a wide application range.

Inputs:

- Start/stop
- Limit switch (positive and negative direction)
- Reference cam
- Jog/tip (positive and negative direction)

Outputs (default setting):

- Target reached
- Error

Operating modes:

- Single positioning with different acceleration ramps
- Reference motion
- Jog
- Tip
- Command table
- Cam switch

Functions include:

- Absolute/relative positioning
- Setpoint change on the fly
- Rotary axis

Protection

- Short circuit monitoring of motor connections: Winding short circuit and short circuit to 0 V and 24 V
- 24 V supply: reverse voltage protection
- Motor supply: reverse voltage protection via external fuse

Stepper module ▶ Servo stepper controller



750-673

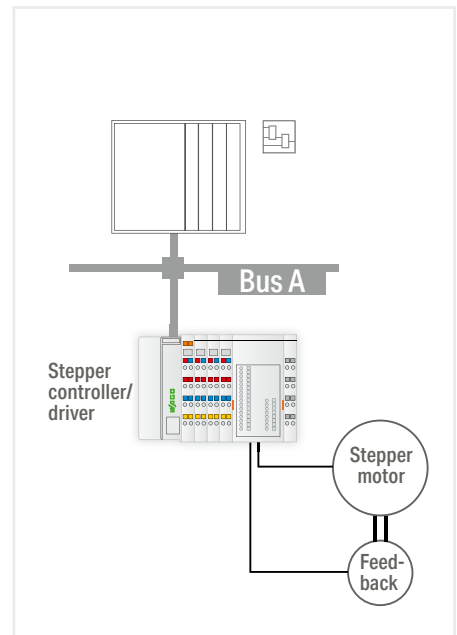
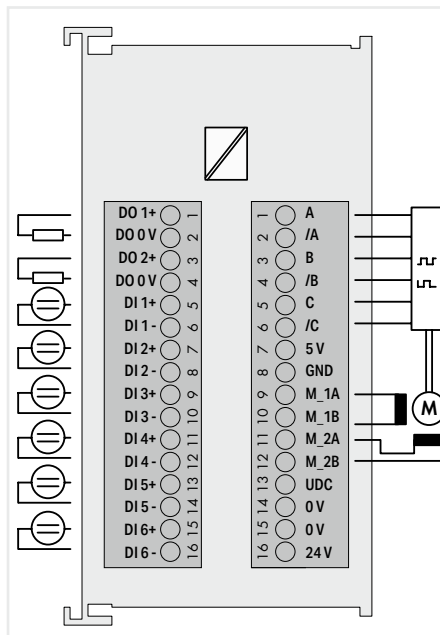

Item description	Servo Stepper Controller; 55 VDC; 7.5 A
Version	Standard
Item no.	750-673
Order Text	Servo Stepper Controller; 55 VDC; 7.5A
Technical data	
Number of motor outputs	1 stepper motor (2 phases)
Supply voltage (motor)	55 VDC; Absolute upper limit: 71.5 V; Absolute lower limit: 18 V
Output current (max.) (motor)	2 x 5.0 A (2 x 7.5 A transient)
Stepper frequency (full-step) max.	7812 Hz
Signal voltage	Compatible with RS-485/-422, common GND with motor voltage and control voltage
Resolution	15 bits + 16 bit prescaler; 64 microsteps per full step
Stepper resolution	23 bits + sign bit
Load type	Resistive load, inductive load (max. 2 H), lamps
Number of digital outputs	2
Output voltage	Control voltage: 24 VDC (-25 % ... +30 %); Closed current: 120 mA + 2 x 0.5 A (DO1, DO2, load-dependent) + approx. 100 mA (encoder); Motor voltage: 55 VDC nominal value; Absolute upper limit: 71.5 V; Absolute lower limit: 18 V; Closed current (typ.) = 5 mA; Protection via external fuse 5 A
Output current per channel	0.5 A
Output current	short-circuit-protected
Switching frequency (max.)	5 Hz; Inductive load per IEC 947-5-1, DC 13
Voltage range for signal (0)	-3 ... +5 VDC
Voltage range for signal (1)	15 ... 30 VDC
Input filter	100 µs, software filter can be connected
Encoder connection	A, /A, B, /B, C, /C
Encoder frequency	1 MHz
Sensor supply	5 VDC, 300 mA, short-circuit-protected
Quadrature decoder	4x evaluation
Counter depth	32 bits
Current consumption (5 V system supply)	70 mA
Data width	12-byte input/output
Isolation	500 V system/field
Ambient temperature (operation)	0 ... +55 °C
Dimensions W x H x D	(48 x 100 x 69.8) mm
Approvals	CE; UL 61800-5-1
For data sheet and additional information, see:	wago.com/750-673

This servo stepper controller has an on-board power driver and an incremental encoder evaluation for controlling 2-phase stepper motors. The 64 times microstepping prevents step losses due to resonance in the acceleration phases and reduces wear on the mechanical parts. Together with the incremental encoder, the integrated vector control contributes to efficient, dynamic rotation speed characteristics. Six configurable inputs are directly processed by the internal software without delay. Two outputs can be linked with internal functions or freely allocated. Versatile functions enable a wide application range.

Inputs:

- Start/stop
- Limit switch (positive and negative direction)
- Reference cam
- Jog/tip (positive and negative direction)

Outputs (default setting):

- Target reached
- Error

Operating modes:

- Single positioning with different acceleration ramps
- Reference motion
- Jog
- Tip
- Command table
- Cam switch

Functions include:

- Absolute/relative positioning
- Setpoint change on the fly
- Rotary axis

Protection

- Short circuit monitoring of motor connections: Winding short circuit and short circuit to 0 V and 24 V
- 24 V supply: reverse voltage protection
- Motor supply: reverse voltage protection via external fuse

DC drive controller



750-636

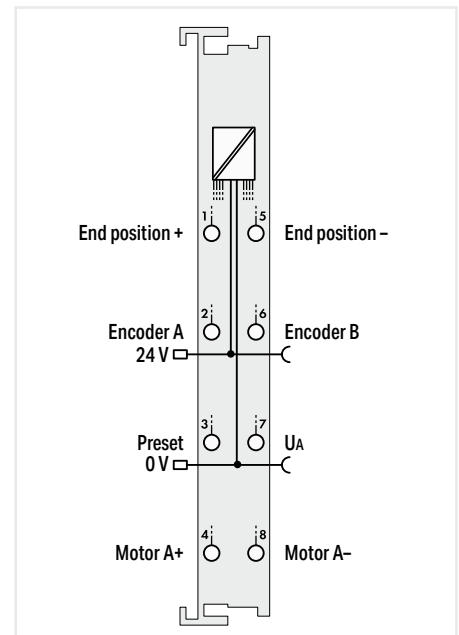
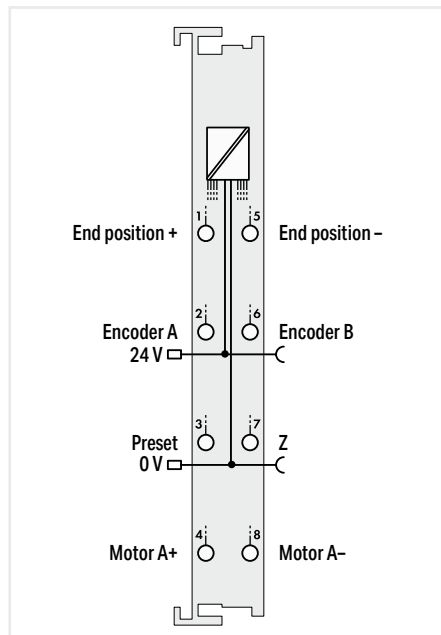

Item description	DC Drive Controller; 24 VDC; 5 A		DC Drive Controller; 24 VDC; 5 A; External motor voltage	
Version	Standard	ext. temperature	Separate motor power supply	Separate motor power supply; interference-free
Item no.	750-636	750-636/025-000	750-636/000-700	750-636/000-800
Order Text	DC-Drive Controller; 24 VDC; 5A	DC-Drive Controller; 24 VDC; 5A; T	DC-Drive Controller; 24 VDC; 5A; UA	DC-Drive Controller; 24 VDC; 5A; IF
Technical data				
Number of outputs	1 (A+; A-; H-bridge output)		1 (A+; A-; H-bridge output)	
Supply voltage (motor)	24 VDC (-20 ... +15 %)		24 VDC (-20 ... +15 %); Separate motor voltage: 24 VDC (-20 ... +30 %)	
Output current (max.) (motor)	5 A (15 A / 500 ms), short-circuit-protected		5 A (15 A / 500 ms), short-circuit-protected	
PWM frequency (typ.)	20 kHz		20 kHz	
Number of digital inputs	3		3	
Input characteristic	Type 1		Type 1	
Input characteristic	high-side switching		high-side switching	
Voltage range for signal (0)	-3 ... +1.5 VDC		-3 ... +1.5 VDC	
Voltage range for signal (1)	2.4 ... 30 VDC		2.4 ... 30 VDC	
Encoder connection	A, B, zero low-side switching; 5 ... 24 VDC / open collector		A, B, zero low-side switching; 5 ... 24 VDC / open collector	
Quadrature decoder	1x, 2x, 4x evaluation		1x, 2x, 4x evaluation	
Supply voltage (field)	24 VDC (-15 ... +20 %); via power jumper contacts (power supply via blade contact; transmission via spring contact)		24 VDC (-15 ... +20 %); via power jumper contacts (power supply via blade contact; transmission via spring contact)	
Current consumption (5 V system supply)	55 mA		55 mA	
Data width	32-bit set/actual value; 16-bit control or status		32-bit set/actual value; 16-bit control or status	
Isolation	500 V system/field		500 V system/field	
Ambient temperature (operation)	0 ... +55 °C		0 ... +55 °C	
Dimensions W x H x D	(12 x 100 x 67.8) mm		(12 x 100 x 67.8) mm	
Approvals	CE		CE	
For data sheet and additional information, see:	wago.com/750-636		wago.com/750-636	

This DC drive controller is a single-channel, intelligent positioning controller for 24 VDC motors up to 5 A with incremental position feedback. Three 24 V inputs record the limit switches and a preset signal. An incremental encoder interface evaluates signals from the position sensor and determines the actual value. Current reduction is possible via pulse width modulation (PWM).

As an option, the motor voltage can be supplied separately.

This DC drive controller is a single-channel, intelligent positioning controller for 24 VDC motors up to 5 A with incremental position feedback. Three 24 V inputs record the limit switches and a preset signal. An incremental encoder interface evaluates signals from the position sensor and determines the actual value. Current reduction is possible via pulse width modulation (PWM).

As an option, the motor voltage can be supplied separately.

Proportional valve controller



750-632

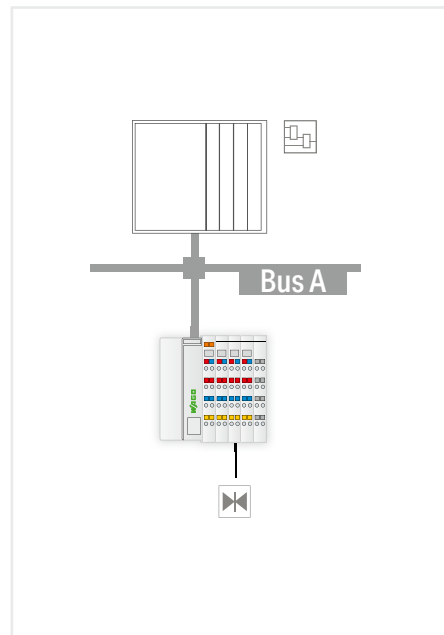
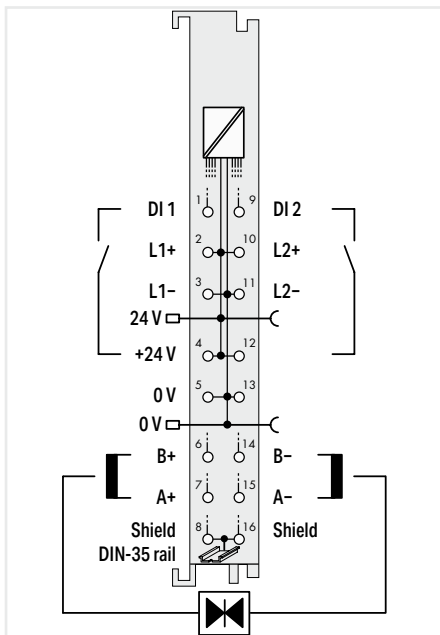

Item description
Version
Item no.
Order Text

Proportional Valve Module
Standard with 16 connectors
750-632
Proportional Valve Module

Technical data

Number of outputs
Type of output
Load type
Output current
Input current (typ.)
Dither frequency
PWM frequency (typ.)
Nominal output voltage
Number of digital inputs
Input characteristic
Input characteristic
Supply voltage (field)
Current consumption (5 V system supply)
Data width
Isolation
Ambient temperature (operation)
Dimensions W x H x D
Approvals

2 bipolar outputs (A+, A- and B+, B-)
H-bridge output with current-regulated PWM output (short-circuit-proof and thermal overload-proof for each channel)
Operating range: inductive (1 mH ... 600 mH); Internal load resistance (> 8 Ohm)
1-channel operation: 2 A; 2-channel operation: 1.6 A per channel
2.7 mA at 24 V
250 Hz; 125 Hz; 62.5 ... 1 Hz (parameterizable)
50 kHz
24 VDC (-25 ... +30 %)
2
Type 1
high-side switching
24 VDC (-25 ... +30 %); via power jumper contacts (power supply via blade contact; transmission via spring contact)
125 mA
6 bytes: single-channel operating mode; 12 bytes: dual-channel operating mode
500 V system/field
0 ... +55 °C
(12 x 100 x 69) mm
CE; Marine; OrdLoc/HazLoc; ATEX/IECEX

For data sheet and additional information, see:

wago.com/750-632

This proportional valve module controls two single-coil valves or one valve.

The module features two current-controlled PWM outputs with adjustable dither. Both unipolar and bipolar valve control are possible. Additionally, operation of a valve with two unipolar coils is also provided. The module is single-channel in this operating mode! Characteristic curve adaptations, such as zero offset, dual gain compensation or range limitations, can be adjusted via parameters.

The module functions can be internally triggered via digital outputs without any detours.

Communication Modules



Housing Design (750 Series)

Dimensions W x H x D	Housing with 4 LEDs: 12 x 100 x 69.8 mm Housing with 8 LEDs: 12 x 100 x 67.8 mm
Depth from upper edge of DIN-rail	Housing with 4 LEDs: 62.6 mm Housing with 8 LEDs: 60.6 mm
Connection technology	CAGE CLAMP®
Conductor cross-section	0.08 ... 2.5 mm ² / 28 ... 14 AWG
Strip length	8 ... 9 mm / 0.33 inch

Housing Design (753 Series)

Dimensions W x H x D	Housing with 4 LEDs: 12 x 100 x 69.8 mm Housing with 8 LEDs: 12 x 100 x 69 mm
Depth from upper edge of DIN-rail	Housing with 4 LEDs: 62.6 mm Housing with 8 LEDs: 61.8 mm
Connection technology	CAGE CLAMP®
Conductor cross-section	0.08 ... 2.5 mm ² / 28 ... 14 AWG
Strip length	9 ... 10 mm / 0.37 inch



RS-485

EnOcean-RS-485-Gateway; 868 MHz

Dimensions Diameter x Height	95 x 36 mm
Protection type	IP30 (front side)
Connection technology	PUSH WIRE®
Conductor cross-section	Solid: 0.4 ... 0.8 mm ² / 26 ... 20 AWG
Strip length	6 ... 7 mm

Housing Design (750 Series), with Push-in CAGE CLAMP® Connections (up to 16 connection points)

Dimensions W x H x D	12 x 100 x 69 mm
Depth from upper edge of DIN rail	61.8 mm
Connection technology	Push-in CAGE CLAMP®
Conductor cross-section	Solid: 0.08 ... 1.5 mm ² / 28 ... 16 AWG Fine-stranded: 0.25 ... 1.5 mm ² / 22 ... 16 AWG
Strip length	8 ... 9 mm / 0.33 inch



I/O System – 750 XTR Series

I/O System – 750 and 753 Series, Communication Modules

Contents

Function	Description	Item Number			Page
		Standard	Extended Temperature	Pluggable	
Serial Interface	Serial Interface RS-232 C; 9600 Baud	750-650		753-650	398
	Serial Interface RS-232 C; 9600 Baud; 5 Bytes	750-650/000-001			398
	Serial Interface RS-232 C; 9600 Baud; Even; 7/2 Bits	750-650/000-002			399
	Serial Interface RS-232 C; 9600 Baud; Even; 8/1 Bits	750-650/000-006			399
	Serial Interface RS-232 C; 19200 Baud; None; 8/1 Bits	750-650/000-010			399
	Serial Interface RS-232 C; 19200 Baud; Even; 8/1 Bits	750-650/000-011			399
	Serial Interface RS-232 C; 2400 Baud; None; 8/1 Bits	750-650/000-012			399
	Serial Interface RS-232 C; 4800 Baud; Even; 8/1 Bits; 5 Bytes	750-650/000-015			399
	Serial Interface RS-232 C; Adjustable	750-650/003-000		753-650/003-000	398
	Serial Interface RS-485	750-653	750-653/025-018	753-653	400
	Serial Interface RS-485; 9600 Baud; Even; 7/2 Bits	750-653/000-001			401
	Serial Interface RS-485; 9600 Baud; Even; 8/1 Bits	750-653/000-002			401
	Serial Interface RS-485; 2400 Baud; None; 8/1 Bits	750-653/000-007			401
	Serial Interface RS-485; Adjustable	750-653/003-000	750-653/025-000	753-653/003-000	400
	Serial Interface RS-232/485	750-652*	750-652/025-000	753-652	402
	Serial Interface RS-232/485/422	750-1652		753-1652	403
	Serial TTY Interface; 9600 Baud; None; 8/1 Bits	750-651			404
	Serial TTY Interface; 9600 Baud; Even; 8/1 Bits	750-651/000-002			404
EnOcean®	EnOcean-RS-485-Gateway; 868 MHz	750-940			405
KNX	KNX/EIB/TP1 Interface			753-646	406
DALI	DALI Multi-Master			753-647	407
LON®	LON® FTT Interface			753-648	408
MP-Bus	MP-Bus Master	750-643			409
M-Bus	M-Bus Master			753-649	410
SMI	SMI Master Module; for Drives with 230 VAC			753-1630	411
	SMI Master Module; Low Voltage			753-1631	411
AS-Interface Master	AS-Interface Master	750-655		753-655	412
IO-Link Master	IO-Link Master	750-657			413
CAN Gateway	CAN Gateway	750-658*			414

Serial interface RS-232 C



750-650/003-000

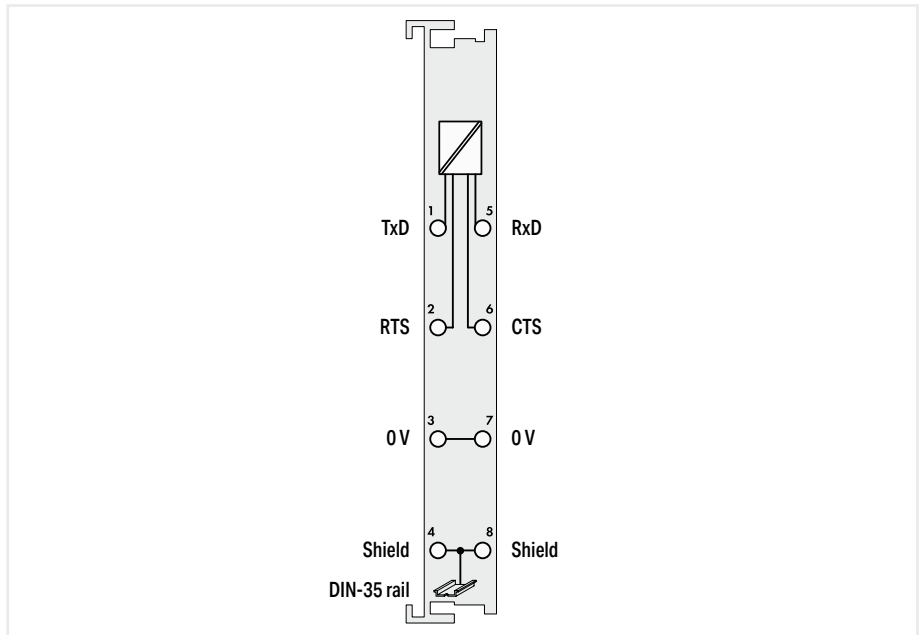

Item description	Serial Interface RS-232 C				
Version	adjustable	pluggable (delivery without connector); adjustable	9600 baud	9600 baud; pluggable (delivery without connector)	9600 baud; 5 bytes
Item no.	750-650/003-000	753-650/003-000	750-650	753-650	750-650/000-001
Order Text	RS232 C Interface; Adjust	RS232 C Interface; Adjust	RS232 C Interface; 9600Bd	RS232 C Interface	RS232 C Interface; 9600Bd; 5byte
Technical data					
Pluggable connector	-	pluggable	-	pluggable	-
Signal type	RS-232				
Transmission channels	1 TxD / 1 RxD, full-duplex				
Baud rate	1.2 kBd ... 57.6 kBd (9600 baud (default setting))		9.6 kBd		
Parity	None/Even, adjustable		None		
Number of data bits	7/8, adjustable		8		-
Number of stop bits	1/2, adjustable		1		-
Buffer	120-byte input / 16-byte output				
Current consumption (5 V system supply)	55 mA				
Data width	1 x 24-bit input/output (3-byte user data); 1 x 40-bit input/output (5-byte user data); 1 x 8-bit control/status		1 x 24-bit input/output (3-byte user data); 1 x 8-bit control/status		1 x 40-bit input/output (5-byte user data); 1 x 8-bit control/status
Isolation	500 V system/field				
Ambient temperature (operation)	0 ... +55 °C				
Dimensions W x H x D	(12 x 100 x 69.8) mm				
Approvals	CE; Marine; OrdLoc/HazLoc; ATEX/IECEX				
For data sheet and additional information, see:	wago.com/750-650/003-000	wago.com/753-650/003-000	wago.com/750-650	wago.com/753-650	wago.com/750-650/000-001
Accessories	Item no.	Item no.	Item no.	Item no.	Item no.
Plug	-	753-110	-	753-110	-

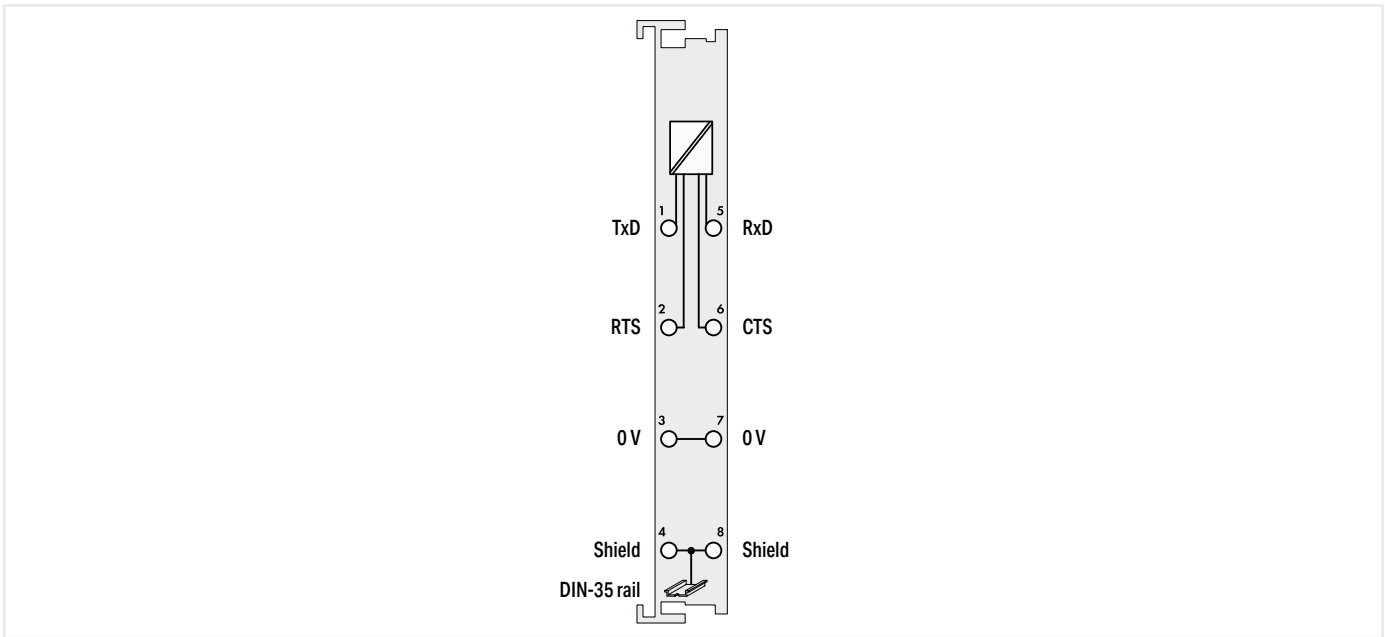

Serial Interface RS-232 C

9600 baud; even; 7/2 bits	9600 baud; even; 8/1 bits	4800 baud; even; 8/1 bits; 5 bytes	2400 baud; none; 8/1 bits	19200 baud; none; 8/1 bits	19200 baud; even; 8/1 bits
750-650/000-002	750-650/000-006	750-650/000-015	750-650/000-012	750-650/000-010	750-650/000-011
RS232 C Interface; 9600Bd; E; 7/2	RS232 C Interface; 9600Bd; E; 8/1	RS232 C Interface; 4800Bd; E; 8/1; 5byte	RS232 C Interface; 2400Bd; N; 8/1	RS232 C Interface; 19200Bd; N; 8/1	RS232 C Interface; 19200Bd; E; 8/1

-					
RS-232					
1 TxD / 1 RxD, full-duplex					
9.6 kBd	4.8 kBd		2.4 kBd	19.2 kBd	
Even			None		Even
7					8
2					1
120-byte input / 16-byte output					
55 mA					
1 x 24-bit input/output (3-byte user data); 1 x 8-bit control/status		1 x 40-bit input/output (5-byte user data); 1 x 8-bit control/status		1 x 24-bit input/output (3-byte user data); 1 x 8-bit control/status	
500 V system/field					
0 ... +55 °C					
(12 x 100 x 69.8) mm					
CE; Marine; OrdLoc/HazLoc; ATEX/IECEX wago.com/750-650/000-001					

Item no.	Item no.	Item no.	Item no.	Item no.	Item no.
-	-	-	-	-	-

Serial interface RS-485



750-653

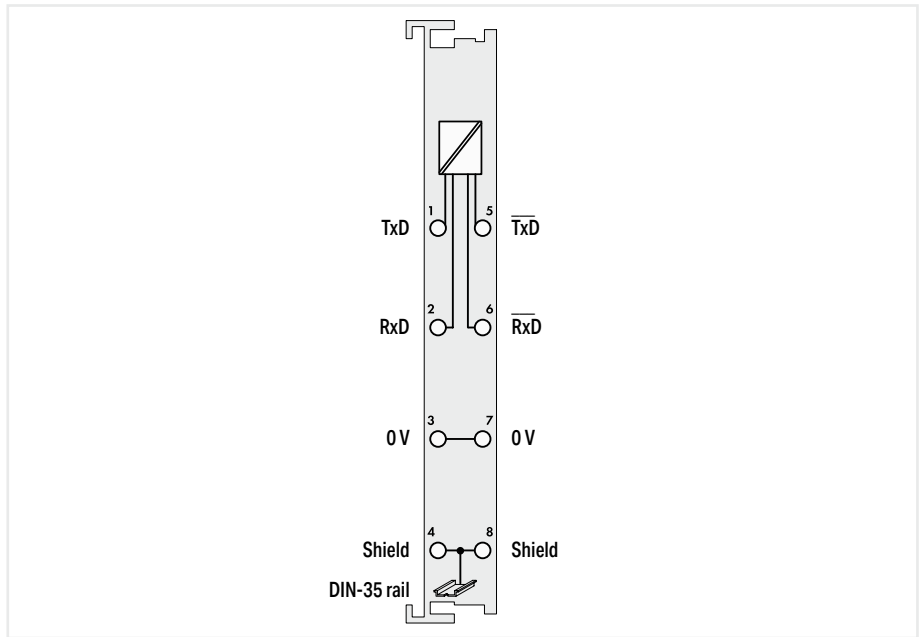

Item description
Version
Item no.
Order Text

Serial Interface RS-485				
Standard	pluggable (delivery without connector)	adjustable	pluggable (delivery without connector); adjustable	adjustable; ext. temperature
750-653	753-653	750-653/003-000	753-653/003-000	750-653/025-000
RS485 Interface	RS485 Interface; 9600Bd; N; 8/1	RS485 Interface; Adjust	RS485 Interface; Adjust	RS485 Interface; Adjust; T

Technical data
Pluggable connector
Signal type
Transmission channels
Baud rate
Parity
Number of data bits
Number of stop bits
Buffer
Current consumption (5 V system supply)
Data width
Isolation
Ambient temperature (operation)
Dimensions W x H x D
Approvals

-	pluggable	-	pluggable	-
RS-422 / RS-485				
1 TxD / 1 RxD, full-duplex				
9.6 kBd	1.2 kBd ... 19.2 kBd (9600 baud (default setting))			
None	None/Even, adjustable			
8	7/8, adjustable			
1	1/2, adjustable			
120-byte input / 16-byte output				
65 mA				
1 x 24-bit input/output (3-byte user data); 1 x 8-bit control/status				
500 V system/field				
0 ... +55 °C				-20 ... +60 °C
(12 x 100 x 69.8) mm				

For data sheet and additional information, see:

wago.com/750-653	wago.com/753-653	wago.com/750-653/003-000	wago.com/753-653/003-000	wago.com/750-653/025-000

Accessories
Plug

Item no.	Item no.	Item no.	Item no.	Item no.
-	753-110	-	753-110	-

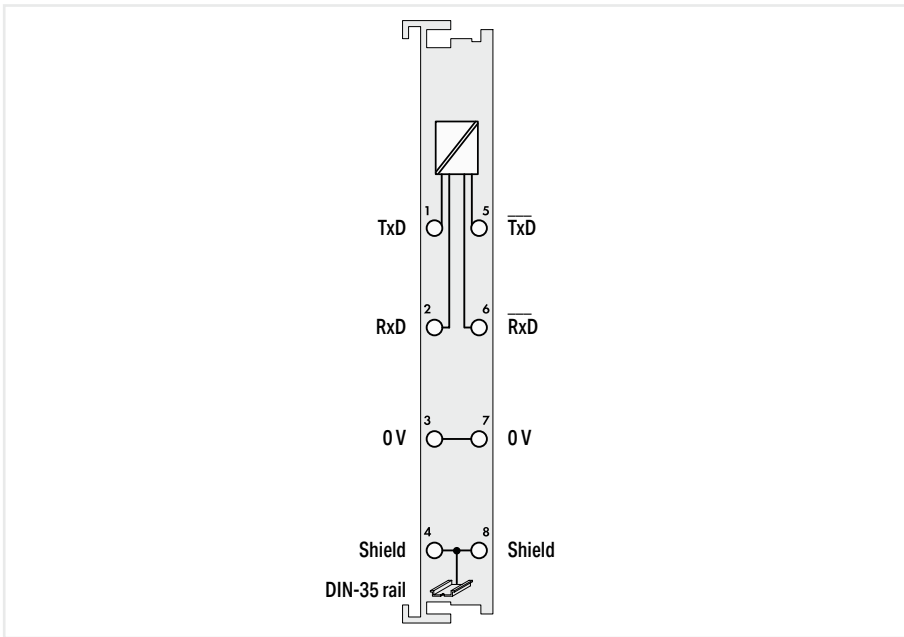

Serial Interface RS-485			
9600 baud; none; 8/1 bits; extended temperature	9600 baud; even; 7/2 bits	9600 baud; even; 8/1 bits	2400 baud; none; 8/1 bits
750-653/025-018	750-653/000-001	750-653/000-002	750-653/000-007
RS485 Interface; 9600Bd; N; 8/1; 5byte; T	RS485 Interface; 9600Bd; E; 7/2	RS485 Interface; 9600Bd; E; 8/1	RS485 Interface; 2400Bd; N; 8/1

RS-422 / RS-485			
1 TxD / 1 RxD, full-duplex			
9.6 kBd		2.4 kBd	
None	Even	None	
8	7	8	
1	2	1	
120-byte input / 16-byte output			
65 mA			
1 x 40-bit input/output (5-byte user data); 1 x 8-bit control/status	1 x 24-bit input/output (3-byte user data); 1 x 8-bit control/status		
500 V system/field		0 ... +55 °C	
-20 ... +60 °C	(12 x 100 x 69.8) mm		
CE, Marine, OrdLoc/HazLoc, ATEX/IECEx wago.com/750-653/025-000			

Item no.	Item no.	Item no.	Item no.
-	-	-	-

Serial interface RS-232/485



750-652

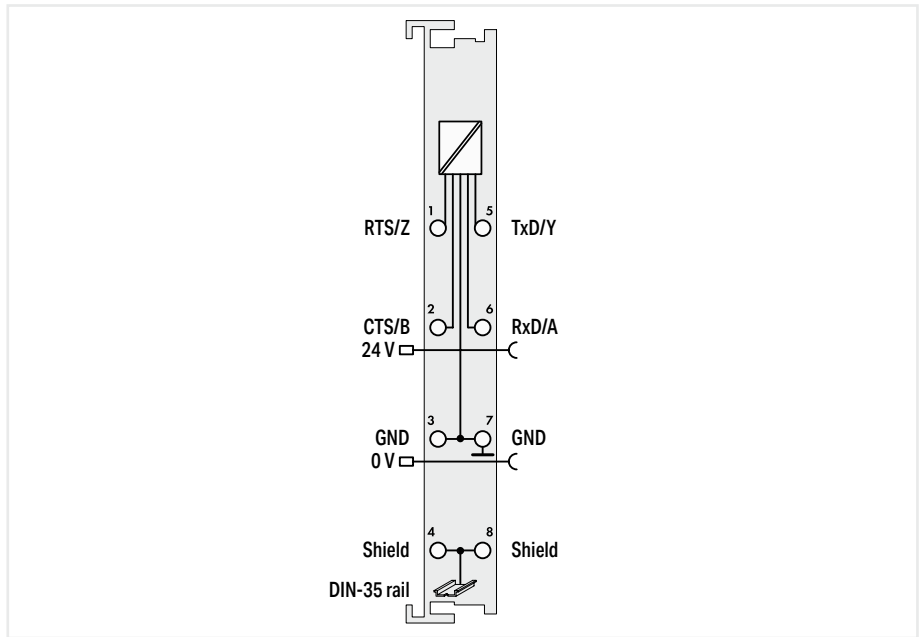

Item description
Version
Item no.
Order Text

Serial Interface RS-232/485		
Standard	ext. temperature	pluggable (delivery without connector)
750-652	750-652/025-000	753-652
RS232/485 Interface	RS232/485 Interface; T	RS232/485 Interface

Technical data
Pluggable connector
Signal type
Transmission channels
Baud rate
Parity
Number of data bits
Number of stop bits
Buffer
Supply voltage (field)
Current consumption (5 V system supply)
Data width
Isolation
Ambient temperature (operation)
Dimensions W x H x D
Approvals
For data sheet and additional information, see:

		pluggable
	RS-232; RS-422 / RS-485	
	1 TxD / 1 RxD, full-duplex, half-duplex	
	300 Bd ... 115.2 kBd	
	None/Odd/Even	
	7/8, adjustable	
	1/2, adjustable	
	2560-byte input / 512-byte output	
	24 VDC; via power jumper contacts (power supply via blade contact; transmission via spring contact)	
	85 mA	
	1 x 46/1 x 22/1 x 6-byte input/output (parameterizable), 2-byte control/status	
	500 V system/field	
	0 ... +55 °C	-20 ... +60 °C
	(12 x 100 x 67.8) mm	(12 x 100 x 69) mm
	CE; Marine; OrdLoc/HazLoc; ATEX/IECEX	
	wago.com/750-652	wago.com/753-652

Accessories
Plug

Item no.	Item no.	Item no.
-	-	753-110

Serial Interface RS-232/485/422



750-652

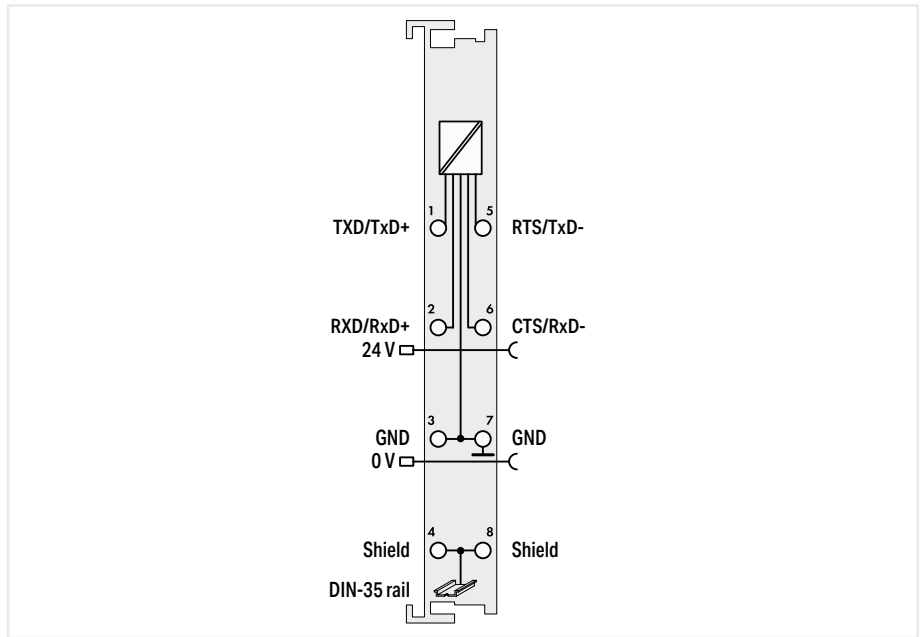

Item description
Version
Item no.
Order Text

Serial Interface RS-232/485/422	
Standard	pluggable (delivery without connector)
750-1652	753-1652
RS-232/485 Serial Interface	RS-232/485 Serial Interface

Technical data	
Signal type	RS-232; RS-422 / RS-485
Transmission channels	1 TxD / 1 RxD, full-duplex, half-duplex
Baud rate	150 Bd ... 250 kBd
Parity	None/Odd/Even/Mark/Space
Number of data bits	7 ... 8, adjustable
Number of stop bits	1/2, adjustable
Buffer	8192-byte input / 2048-byte output
Supply voltage (field)	24 VDC; via power jumper contacts (power supply via blade contact; transmission via spring contact)
Current consumption (5 V system supply)	120 mA
Data width	Serial modes: 1 x 46/1 x 22/1 x 6-byte input/output (parameterizable), 2-byte control/status
Isolation	500 V system/field
Ambient temperature (operation)	0 ... +55 °C
Dimensions W x H x D	(12 x 100 x 67.8) mm (12 x 100 x 69) mm
Approvals	CE
Approvals (pending)	Marine; OrdLoc/HazLoc
For data sheet and additional information, see:	wago.com/750-1652 wago.com/753-1652

Item no.	Item no.
-	753-110

Accessories
Plug

Serial TTY interface



750-651

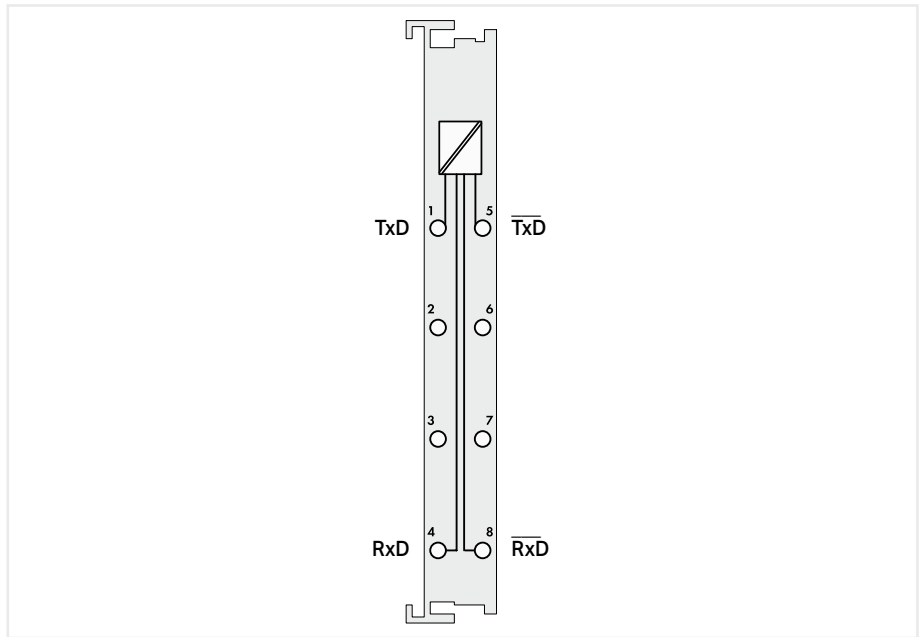

Item description	Serial TTY Interface	
Version	9600 baud; none; 8/1 bits	9600 baud; even; 8/1 bits
Item no.	750-651	750-651/000-002
Order Text	TTY Interface; 9600Bd; N; 8/1	TTY Interface; 9600Bd; E; 8/1
Technical data		
Signal type	TTY, 20 mA	
Transmission channels	1 TxD / 1 RxD, full-duplex	
Baud rate	1.2 kBd ... 19.2 kBd (9600 baud (default setting))	
Load impedance (current output) max.	500 Ω	
Parity	None	Even
Number of data bits	8	
Number of stop bits	1	
Buffer	128-byte input / 16-byte output	
Current consumption (5 V system supply)	55 mA	
Data width	1 x 24-bit input/output (3-byte user data); 1 x 8-bit control/status	
Isolation	500 V system/field	
Ambient temperature (operation)	0 ... +55 °C	
Dimensions W x H x D	(12 x 100 x 69.8) mm	
Approvals		

For data sheet and additional information, see:

wago.com/750-651

EnOcean® RS-485 Gateway



750-940

Item description
Version
Item no.

EnOcean® RS-485 Gateway; 868 MHz
direct ceiling/wall mounting or mounting rail (through integrated adapter)
750-940

Technical Data	
Wireless technology	EnOcean®
Frequency band	868 MHz
Transmission range	Approx. 30 m within buildings; >100 m in open space
Antenna	Internal (external antenna optional via SMA socket)
Interface	RS-485
Protocol	ESP3, Modbus®
Transmission rate	9600 ... 115200 Baud
Data width	50 bytes
Cable length	100 m (max.)
Power supply	24 VDC (-25 ... +30 %)
Input current	2 A (max.)
Connection technology	RS-485 connection: 5-pole 2-conductor compact PCB connectors with PUSH WIRE® (252-155 is included); Supply connection: 2-pole 2-conductor compact PCB connectors with PUSH WIRE® (252-152 is included); Antenna: SMA socket for external antenna
Conductor cross-section	Solid: 0.4 ... 0.8 mm² / 26 ... 20 AWG
Strip length	6 ... 7 mm
Dimensions (mm) Diameter x Height	95 x 36
Weight	103 g
Protection type	IP30 (front side)
Surrounding air temperature (operation)	0 ... +55 °C
Surrounding air temperature (storage)	-20 ... +85 °C
EMC immunity to interference	EN 61000-6-2
EMC emission of interference	EN 61000-6-3 + A1
Approvals	CE

For data sheet and additional information, see::

wago.com/750-940

The EnOcean® RS-485 Gateway integrates maintenance-free, battery-free and wireless sensors/actuators based on EnOcean® wireless technology (ISO/IEC 14543-3-1x) into intelligent control systems such as the WAGO I/O System. This gateway communicates with the remote station via RS-485 interface and ESP3 telegrams (EnOcean®) or via Modbus® protocol.

It may be mounted directly to the ceiling or wall. The device can also be mounted on a DIN-rail via an integrated adapter. The gateway has an internal antenna and also has a connector for an optional external antenna.

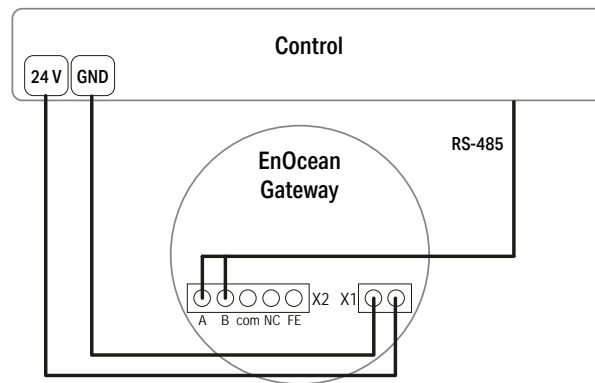

KNX/EIB/TP1 Interface



753-646

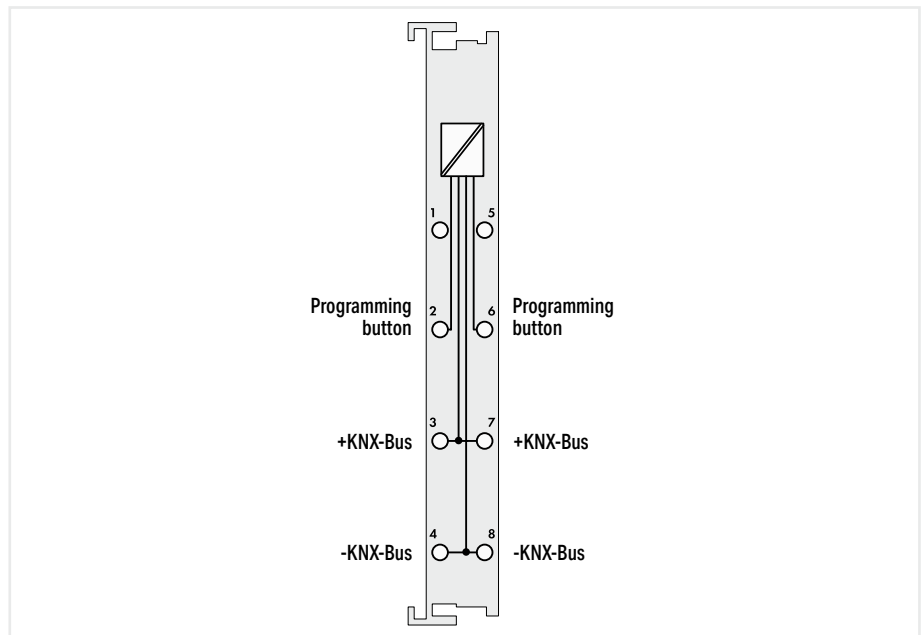

Item description	KNX/EIB/TP1 Interface
Version	pluggable
Item no.	753-646
Order Text	KNX/EIB/TP1 Interface
Technical data	
Pluggable connector	pluggable
Device specification	KNX/TP1 Bus Specification: 1.0
Device-specific	Number of group addresses: 254; Number of communication objects: 253; Number of associations: 254
Baud rate	9.6 kBd (KNX)
Power supply	KNX: via KNX power supply unit
Connection point (other) designation	Programming button; bridge 2/6
Application	on controllers
Commissioning	WAGO-I/O-PRO V2.3
Current consumption (5 V system supply)	25 mA
Data width	24 bytes
Isolation	2.5 kV (rms)
Ambient temperature (operation)	0 ... +55 °C
Dimensions W x H x D	(12 x 100 x 69) mm
Approvals	CE; Marine; OrdLoc

For data sheet and additional information, see:

wago.com/753-646

The KNX/EIB/TP1 Module connects to a KNX/EIB/TP1 network. This module supports two different functions:

1. Device mode:

With this module, all programmable fieldbus controllers relevant for building automation can be connected to a KNX/TP1 network. The module is a standard KNX device and is linked via ETS Professional Commissioning Tool. An ETS plug-in is required so that data from the application program can be allocated to group addresses for the programming software.

2. Router mode:

When connected to a KNX/IP Controller (e.g., 750-889), the combination becomes a KNXnet/IP router. The module is switched to the router mode automatically. An application program is not required for operation in router mode. Additional modules that are connected to a KNX IP Controller are addressed in device mode by the application. The bus connections are internally bridged inside the plug, so the bus is not interrupted when the plug is pulled from the module. The plug is included with delivery.

DALI Multi-Master



753-647

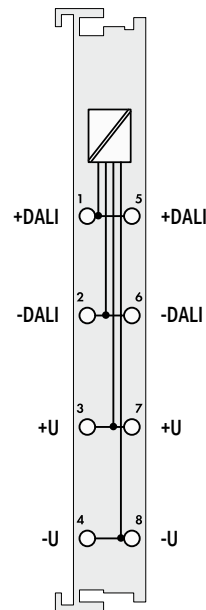

Item description
Version
Item no.
Order Text

DALI Multi-Master
pluggable
753-647
DALI Multi-Master

Technical data
Pluggable connector
Device specification
Device-specific
Topology
Power supply
Application
Commissioning
Current consumption (5 V system supply)
Data width
Isolation
Ambient temperature (operation)
Dimensions W x H x D
Approvals
For data sheet and additional information, see:

pluggable
DALI-2 Specification: DIN IEC 62386 only in conjunction with 753-620 or 787-2857 Power Supplies
Current consumption from DALI bus with alternative supply via DALI bus: 10 mA
Number of control gears/control devices (DALI): 64 control gears + 64 control devices (addressable)
DALI: 18 V (external)
for programmable fieldbus controllers
via WAGO-I/O-CHECK
85 mA
24-byte data
2100 VDC DALI bus/local bus
0 ... +55 °C
(12 x 100 x 69) mm
CE; Marine; OrdLoc
wago.com/753-647

Accessories
DALI Multi-Master DC/DC Converter
Power supply; Compact; 1-phase; 18 VDC output voltage; 1.25 A output current

Item no.
753-620
787-2857

This manufacturer-independent DALI standard ensures interoperability of DALI devices in lighting applications. This standard is substitute for the 1–10 V dimmer interface.

In addition to 64 DALI actuators (ECGs), a DALI Multi-Master Module supports up to 16 multi-sensors (max. 64 sensor addresses). Each DALI ECG can be assigned to 16 groups and 16 scenes. The DALI Multi-Master Module also offers 16 additional virtual groups on the DALI bus.

DALI control devices can be seamlessly integrated with all other building systems. Several DALI masters can be connected to a single fieldbus node. The maximum number of modules that can be connected to a controller depends on the memory required by the application. Function blocks prepared for DALI are available for programming fieldbus nodes.

Alternatively, an "EASY Mode" allows lighting functions to be readily controlled without any PLC programming. The DALI Configurator (Section "Software") simplifies commissioning of the DALI network. It provides the following functions: easy commissioning, configuration, service, support and maintenance of the DALI network.

LON® FTT Interface



753-648

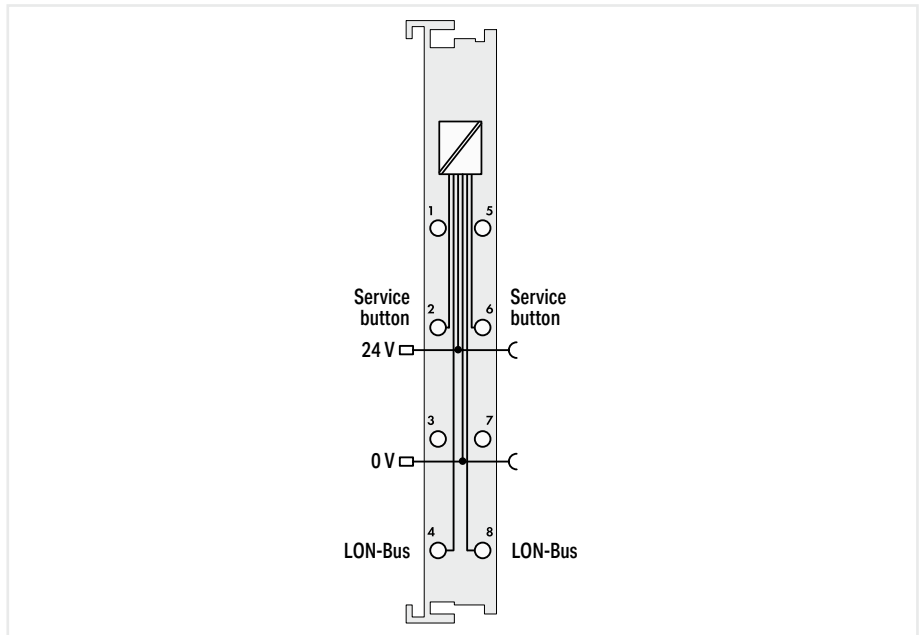

Item description	LON® FTT Interface
Version	pluggable
Item no.	753-648
Order Text	LON FTT Interface
Technical data	
Pluggable connector	pluggable
Device-specific	Number of network variables: max. 254 (249 for application)
Number of aliases (max.)	127
Baud rate	0.078 Mbit/s
Bus segment length (max.)	500 m (free topology); 2700 m (bus topology)
Transmission medium	Twisted pair – FTT
Topology	per LON specification
Application	for controllers; max. 2 per controller
Commissioning	via WAGO-I/O-CHECK or WAGO-I/O-PRO V2.3
Supply voltage (field)	24 VDC; via power jumper contacts (power supply via blade contact; transmission via spring contact)
Current consumption (5 V system supply)	30 mA
Data width	24-byte data
Isolation	500 V system/field
Ambient temperature (operation)	0 ... +55 °C
Dimensions W x H x D	(12 x 100 x 69) mm
Approvals	CE, OrdLoc/HazLoc
For data sheet and additional information, see:	wago.com/753-648

The LON® FTT Interface is a full-fledged and flexible LON® device within LonWorks® FT or LP network. The module's network variable interface defines 249 network variables of any type and supports both LonMark® objects and configuration properties.

MP-Bus Master



750-643

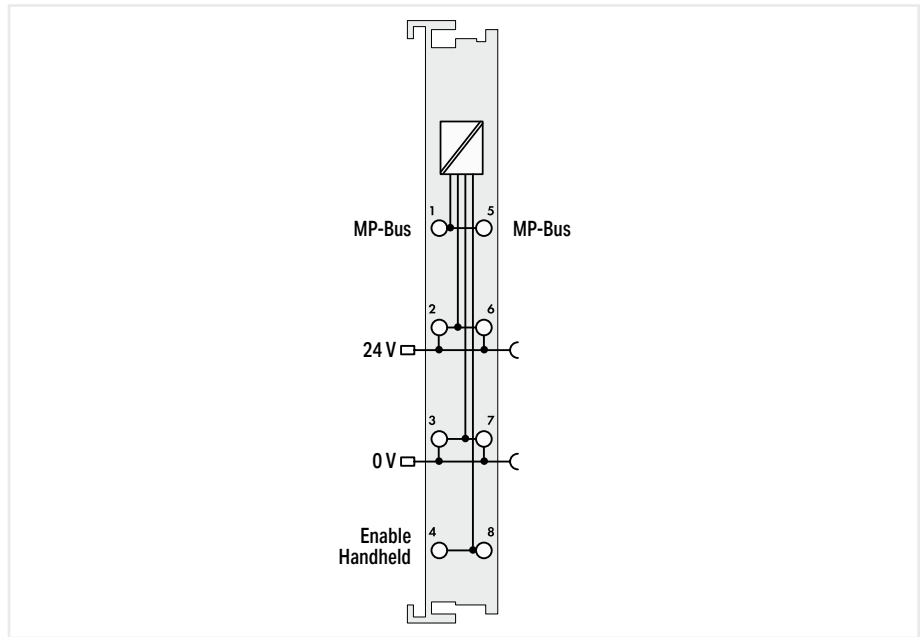

Item description	MP-Bus Master
Version	Standard
Item no.	750-643
Order Text	MP-Bus Master

Technical data	
Device specification	MP-Bus Specification: PP/MP Specification V1.21 from Belimo (Valid since 1.10.2002)
Topology	Number of participants: 8 slaves (max.)
Power supply	MP-Bus: 24 VDC, via power jumper contacts on controllers
Application	24 VDC; via power jumper contacts (power supply via blade contact; transmission via spring contact)
Supply voltage (field)	15 mA
Current consumption (5 V system supply)	1-byte C/S, 7-byte data
Data width	500 V (rms) MP-Bus/system
Isolation	0 ... +55 °C
Ambient temperature (operation)	(12 x 100 x 69.8) mm
Dimensions W x H x D	CE, OrdLoc/HazLoc, ATEX/IECEX
Approvals	wago.com/750-643
For data sheet and additional information, see:	

MP-Bus Master
Standard
750-643
MP-Bus Master

MP-Bus Specification: PP/MP Specification V1.21 from Belimo (Valid since 1.10.2002)
Number of participants: 8 slaves (max.)
MP-Bus: 24 VDC, via power jumper contacts on controllers
24 VDC; via power jumper contacts (power supply via blade contact; transmission via spring contact)
15 mA
1-byte C/S, 7-byte data
500 V (rms) MP-Bus/system
0 ... +55 °C
(12 x 100 x 69.8) mm
CE, OrdLoc/HazLoc, ATEX/IECEX
wago.com/750-643

This module acts as a master for the MP bus (Multi-Point bus from Belimo/Switzerland) and allows the bus to be integrated into a higher level bus network. The MP-Bus controls HVAC actuators for dampers, regulator valves or VAV air volume controls.

The actuators have connections for sensors (temperature, humidity, on/off switch) that are also accessible via MP-Bus. An MP-Bus master can manage up to 8 slaves (actuators) + 8 sensors (1 sensor per slave) via a common bus line, which considerably reduces actuator and sensor wiring.

M-Bus Master



753-649

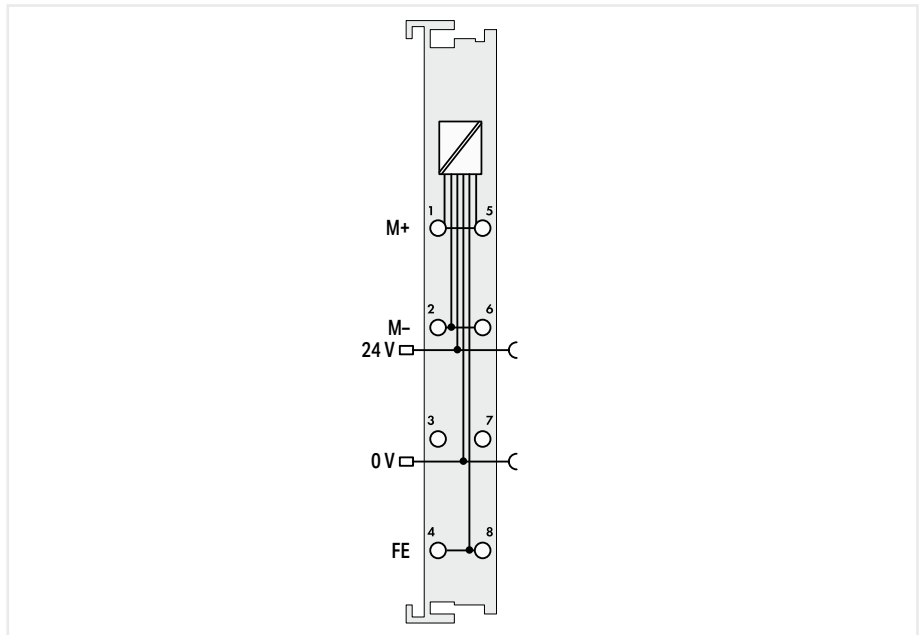

Item description	M-Bus Master
Version	pluggable
Item no.	753-649
Order Text	M-Bus Master
Technical data	
Pluggable connector	pluggable
Device-specific	Line length (overall network): up to 1000 m at 9600 baud; up to 2000 m at 2400 baud; up to 6000 m at 300 baud; Master/slave distance: up to 500 m at 9600 baud; up to 1000 m at 2400 or 300 baud; M-Bus loads (max.): 40 (1.5 mA each); Overcurrent shutdown: Active current monitoring; Threshold value: approx. 120 mA; Minimum shutdown time: 500 ms
Transmission channels	1, bidirectional
Baud rate	300 Bd ... 9.6 kBd (2400 baud (default))
Topology	Star, tree and line topology
Connection requirement (permissible cable type)	2-line, shielded or unshielded
Commissioning	WAGO-I/O-PRO V2.3, e!COCKPIT
Supply voltage (field)	24 VDC (-2.5 ... +5 %); via power jumper contacts (power supply via blade contact; transmission via spring contact)
Current consumption (5 V system supply)	40 mA
Data width	24 bytes (mailbox 2.0 with 22-byte length)
Isolation	500 V system/field
Ambient temperature (operation)	0 ... +55 °C
Dimensions W x H x D	(12 x 100 x 69.8) mm
Approvals	CE, OrdLoc/HazLoc
For data sheet and additional information, see:	wago.com/753-649

SMI Master Module



753-1631

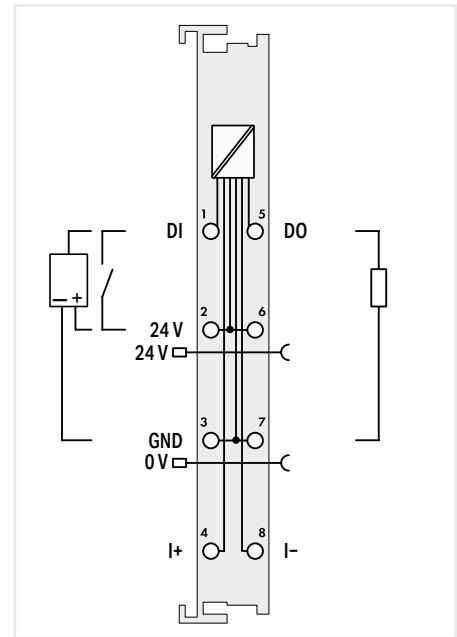
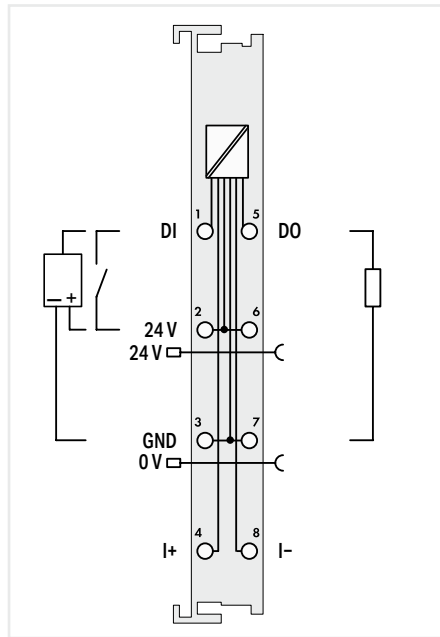

Item description
Version
Item no.
Order Text

SMI Master Module; Low voltage
LoVo; pluggable
753-1631
SMI Master LoVo; 24 VDC

SMI Master Module; for drives with 230 VAC
pluggable
753-1630
SMI Master; 230 VAC

Technical data	
Pluggable connector	
Device specification	
Number of SMI channels	
Number of digital inputs	
Input characteristic	
Input voltage (max.)	
Number of digital outputs	
Output current per channel	
Connection requirement (permissible cable type)	
Connection requirement (permissible cable length)	
Commissioning	
Supply voltage (field)	
Current consumption (5 V system supply)	
Data width	
Isolation	
Ambient temperature (operation)	
Dimensions W x H x D	
Approvals	

pluggable	
SMI Master Interface per "SMI Data Format and Framework Protocol" Specifications Rev. 2.3.2 and "HMI Hardware Specification" Rev. 2.0	
Number of SMI channels	1 (1 ... 16 SMI slaves per channel)
Number of digital inputs	1
Input characteristic	Type 1
Input voltage (max.)	31.2 VDC
Number of digital outputs	1
Output current per channel	0.5 A
Connection requirement (permissible cable type)	2-line, unshielded
Connection requirement (permissible cable length)	350 m
Commissioning	via WAGO SMI Configurator or IEC libraries
Supply voltage (field)	24 VDC (-25 ... +30 %); via power jumper contacts (power supply via blade contact; transmission via spring contact)
Current consumption (5 V system supply)	42 mA
Data width	12-byte data
Isolation	3 kVAC RMS, 4 kV surge (system/SMI); 1.5 kVAC RMS, 2.5 kV surge (system/field)
Ambient temperature (operation)	0 ... +55 °C
Dimensions W x H x D	(12 x 100 x 69.8) mm
Approvals	CE
For data sheet and additional information, see:	wago.com/753-1631

pluggable	
SMI Master Interface per "SMI Data Format and Framework Protocol" Specifications Rev. 2.3.2 and "HMI Hardware Specification" Rev. 2.0	
Number of SMI channels	1 (1 ... 16 SMI slaves per channel)
Number of digital inputs	1
Input characteristic	Type 1
Input voltage (max.)	31.2 VDC
Number of digital outputs	1
Output current per channel	0.5 A
Connection requirement (permissible cable type)	2-line, unshielded
Connection requirement (permissible cable length)	350 m
Commissioning	via WAGO SMI Configurator or IEC libraries
Supply voltage (field)	24 VDC (-25 ... +30 %); via power jumper contacts (power supply via blade contact; transmission via spring contact)
Current consumption (5 V system supply)	42 mA
Data width	12-byte data
Isolation	3 kVAC RMS, 4 kV surge (system/SMI); 1.5 kVAC RMS, 2.5 kV surge (system/field)
Ambient temperature (operation)	0 ... +55 °C
Dimensions W x H x D	(12 x 100 x 69.8) mm
Approvals	CE
For data sheet and additional information, see:	wago.com/753-1630

AS-Interface Master



750-655

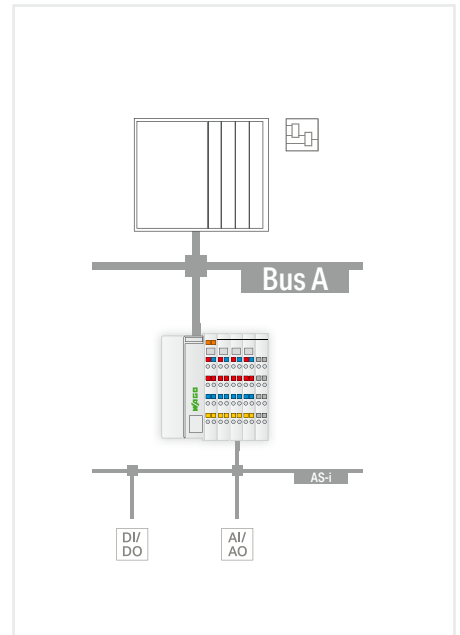
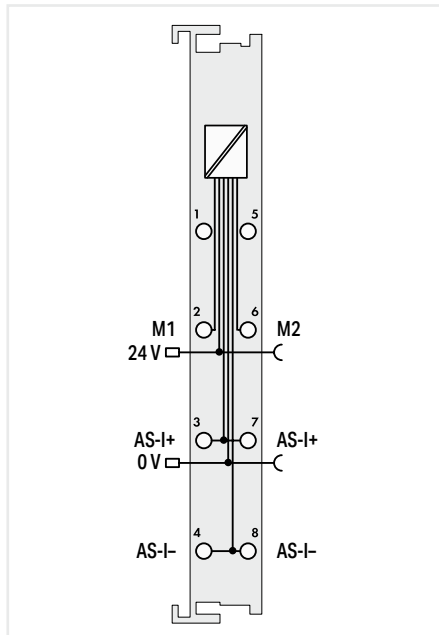

Item description
Version
Item no.
Order Text

AS-Interface Master	
Standard	pluggable (delivery without connector)
750-655	753-655
AS-Interface Master	AS-InterfaceMaster

The AS-Interface Master Module connects AS-Interface devices to a higher-level fieldbus.

It acts as a master for the AS-Interface and via the fieldbus coupler, as a slave for the fieldbus. The AS-i functions are provided both cyclically and acyclically via the fieldbus.

Technical data
Pluggable connector
Device specification
Device-specific
Topology
Cycle time (AS-I)
Power supply
Supply voltage (field)
Current consumption (5 V system supply)
Data width
Isolation
Ambient temperature (operation)
Dimensions W x H x D
Approvals
For data sheet and additional information, see:
Accessories
Plug

-	pluggable
AS-i master class: M4; AS-I Specification: 3.0	
AS-I cable length (max.): 100 m, with repeater 300 m	
Number of slaves: up to 62; Slave profiles: V3.0 with transaction types 1 ... 5	
0.3 ... 10 ms, depending on the number of slaves	
AS-I: 26.5 ... 31.6 V	
24 VDC (-15 ... +20 %); via power jumper contacts (power supply via blade contact; transmission via spring contact)	
55 mA	
12 ... 48 bytes (max.), configurable, including 1 byte control/status	
500 V system/supply/AS-I	
0 ... +55 °C	
(12 x 100 x 67.8) mm	(12 x 100 x 69) mm
CE, Marine, OrdLoc/HazLoc, ATEX/IECEX	
wago.com/750-655	wago.com/753-655
Item no.	Item no.
-	753-110

Diagnostics, which go far beyond the AS-i specifications, simplify detection of both sporadic configuration errors and AS-i communication interference sources. An auto-installation mode allows an AS-Interface network to be created via sequential slave installation, with no addressing tool required.

Both signal transmission and operating status, as well as trouble-free local bus communication, are indicated via LEDs.

IO-Link Master



750-657

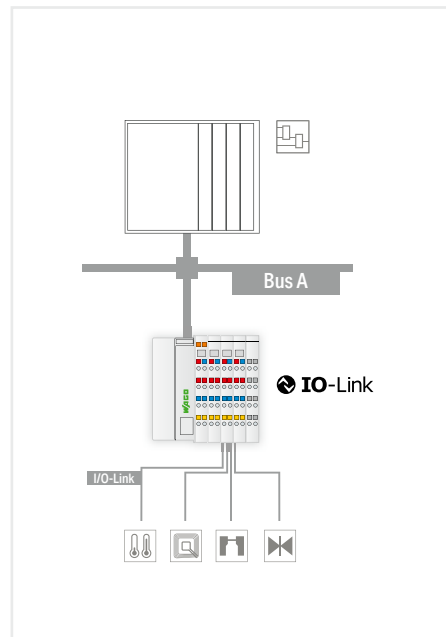
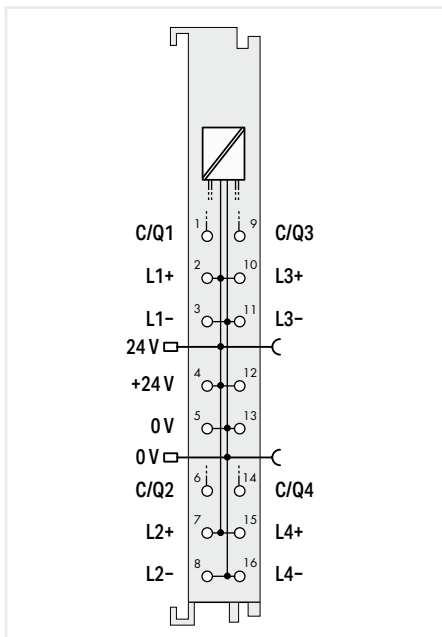

Item description
Version
Item no.
Order Text

IO-Link Master
Standard with 16 connectors
750-657
IO-Link Master

Four different IO-Link devices or standard digital sensors/actuators can simultaneously connect to the IO-Link Master. Process data, as well as acyclic data for identification, configuration, parameterization and diagnostics can be communicated to the respective device via a 3-wire connection.

Technical data
Transmission modes
Topology
Connection requirement (permissible cable length)
Supply voltage (field)
Current consumption (5 V system supply)
Data width
Isolation
Ambient temperature (operation)
Dimensions W x H x D
Approvals

4.8 kBaud (COM 1), 38.4 kBaud (COM 2), 230.4 kBaud (COM 3)
Number of IO-Link ports: 4
20 m
24 VDC (-15 ... +20 %); via power jumper contacts (power supply via blade contact; transmission via spring contact)
40 mA
4–24 bytes, configurable
500 V system/field
0 ... +55 °C
(12 x 100 x 69) mm
CE, OrdLoc/HazLoc; ATEX/IECEx

The functions and performance data are defined in device description files for master and devices; these are easy to customize via engineering tool. If a device must be replaced, the IO-Link devices' configuration and parameterization can be automatically restored without maintenance personnel. This makes project design, installation and operation considerably simpler!

For data sheet and additional information, see:

wago.com/750-657

CAN Gateway



750-658

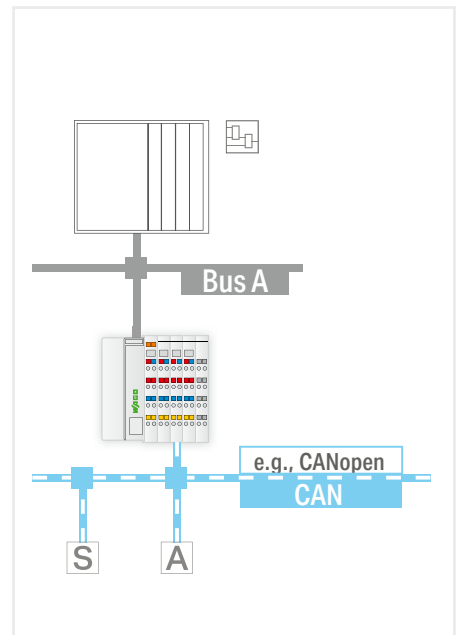
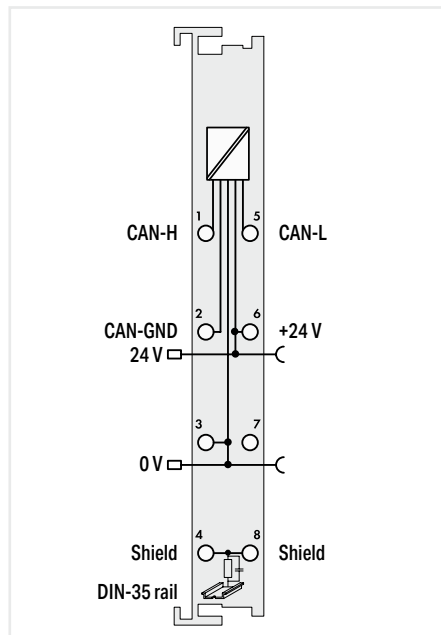

Item description	CAN Gateway
Version	Standard
Item no.	750-658
Order Text	CAN Gateway
Technical data	
Device-specific	Operating modes: Sniffer mode, transparent mode, mapped mode
Number of inputs	1 (CAN interface)
Transmission modes	10 kbit/s; 20 kbit/s; 50 kbit/s; 125 kbit/s; 250 kbit/s; 500 kbit/s; 800 kbit/s (auto-baudrate); Data formats: per 2.0 A standard (11-bit ID); per 2.0 B extended (29-bit ID)
Supply voltage (field)	24 VDC; via power jumper contacts (power supply via blade contact; transmission via spring contact)
Current consumption (5 V system supply)	50 mA
Data width	Configurable to 8, 12, 16, 20, 24, 32, 40, 48 bytes; incl. control/status byte
Ambient temperature (operation)	0 ... +55 °C
Dimensions W x H x D	(12 x 100 x 67.8) mm
Approvals	CE, Marine, OrdLoc/HazLoc, ATEX/IECEX
For data sheet and additional information, see:	wago.com/750-658

The CAN Gateway allows a CAN bus to be installed as a sub-bus beneath a fieldbus coupler or controller. It enables special sensors/actuators that are only available with the widely used CAN bus to also be integrated under other bus systems. Function blocks allow the gateway to read and write higher-protocol telegrams, e.g., CANopen.

The module offers three different operating modes:

- Sniffer mode: Detailed analysis of the CAN bus through passive "snooping"
- Transparent mode: Active CAN subscriber that can send and receive any type of CAN telegram
- Mapped mode: Enables direct generation of CAN telegrams from the process image, or selective copying of process values from received CAN telegrams into the input process image (cyclic or event-based).



Housing Design (750/753 Series)

Dimensions W x H x D	750 Series: 12 or 24 x 67.8 x 100 mm 753 Series: 12 or 24 x 69 x 100 mm
Height from upper edge of DIN-rail	750 Series: 60.6 mm; 753 Series: 61.8 mm
Connection technology	CAGE CLAMP®
Conductor cross-section	0.08 ... 2.5 mm ² / 28 ... 14 AWG
Strip length	750 Series: 8 ... 9 mm / 0.33 inch 753 Series: 9 ... 10 mm / 0.37 inch

Specialty Housing

Dimensions W x H x D	48 x 69.8 x 100
Height from upper edge of DIN-rail	62.6 mm
Connection technology	Push-in CAGE CLAMP®
Conductor cross-section	0.05 ... 1.5 mm ² / 20 ... 14 AWG
Strip length	8 ... 9 mm / 0.33 inch

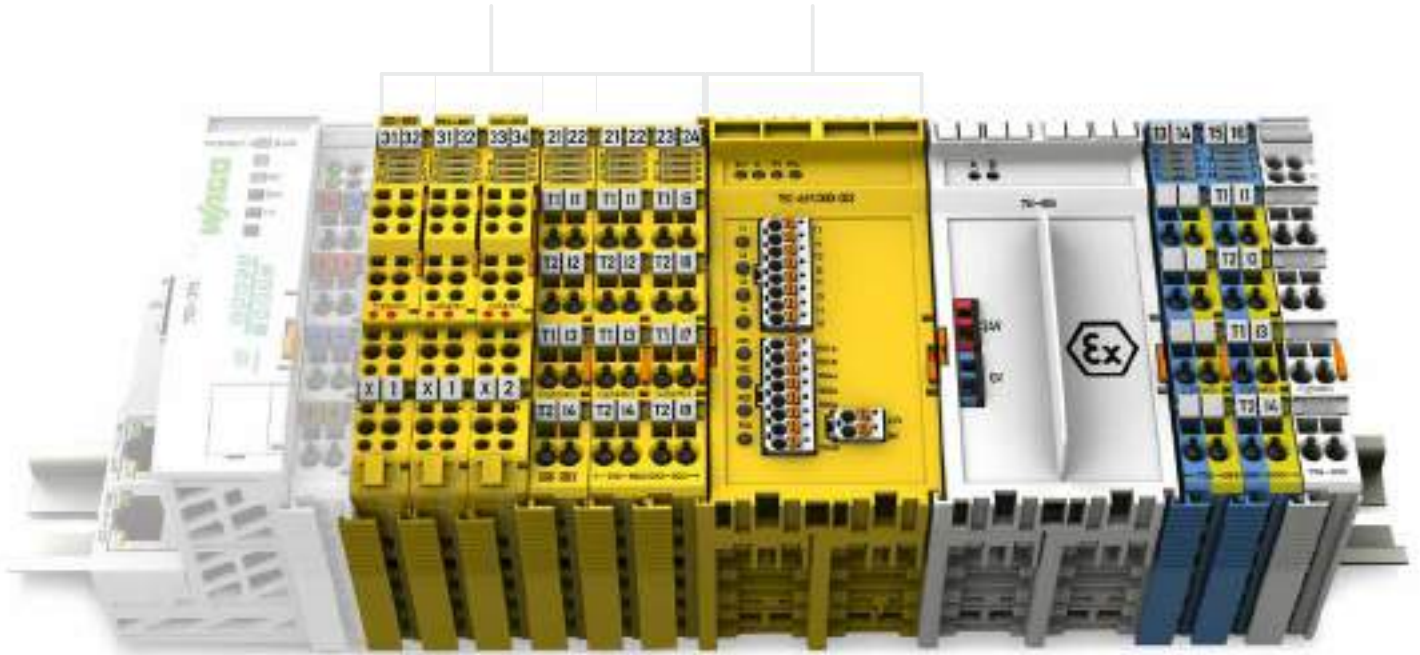

Functional Safety

In the European Union, the machinery directive defines the requirements for machine and system safety. This ensures a uniform standard for protecting the "life and limb" of workers within a machine's operating area.

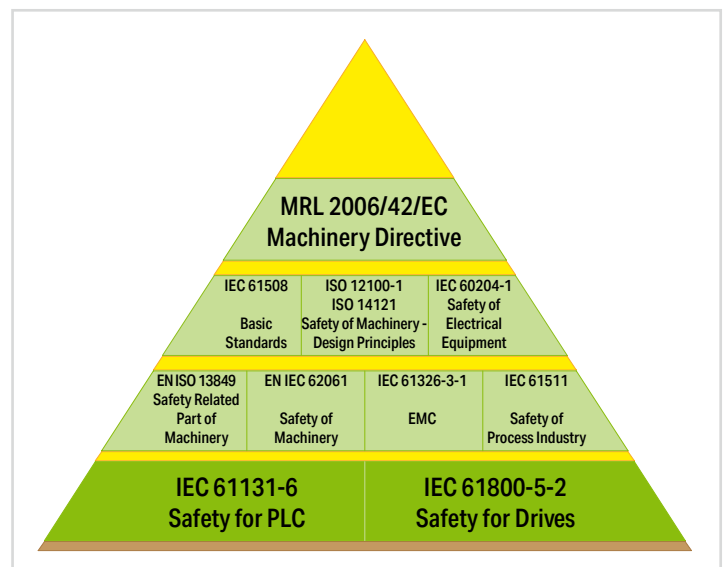

The required risk assessment is based on harmonized standards (e.g., EN 13849) and identifies existing risks and required risk reduction (SIL or PL quality). Based on the risk assessment, safety functions can be implemented, e.g., by presence detection or protection zone violations, using secure switches or light arrays to shut down the "risk" immediately. For this purpose, the safety signals are detected by the "yellow" safety modules and transmitted via "PROFsafe" to the fail-safe PLC for additional processing. The result is then executed via safe actuator (e.g., output module or controller).

The unique safety characteristics of the WAGO modules facilitate calculation of the final safety function up to Cat. 4/PL according to EN 13849, or SIL3 according to EN 62061 or IEC 61511.



I/O System – 750 and 753 Series, Functional Safety

Contents

Function	Description	Item Number		Page
		Standard	Pluggable	
Fail-Safe Digital Input; PROFIsafe	Safe 4-channel digital input; 24 VDC; PROFIsafe	750-661/000-004	753-661/000-004	422
	Safe 8-channel digital input; 24 VDC; PROFIsafe	750-662/000-004	753-662/000-004	423
Fail-Safe Digital Input/Output; PROFIsafe	Safe 4/2 channel digital input/output; 24 VDC; 10 A; PROFIsafe	750-666/000-004		424
	Safe 4/4 channel digital input/output; 24 VDC; 2 A; PROFIsafe	750-667/000-004	753-667/000-004	425
	Safe 4/4 channel digital input/relay output; 48 VAC/60 VDC; 6 A; PROFIsafe V2.0 iPar	750-669/000-003		426
Intrinsically Safe Digital Input for Functional Safety	Intrinsically Safe 4-Channel Digital Input; 24 VDC; PROFIsafe V 2.0 iPar	750-663/000-003		428
Fail-Safe Analog Input; PROFIsafe	Safe 4 channel analog input; 0/4 ... 20 mA; Differential input; PROFIsafe	750-668/000-004	753-668/000-004	427
	Classification of binary 24 V interfaces with functional safety testing according to Position Paper CB24I of the German Electrical and Electronic Manufacturer's Association (ZVEI)			418
Power Supply Ex i 	The intrinsically safe I/O module with inputs for functional safety (750-663/000-003) must only be operated with a 24 VDC Ex i supply module (e.g., 750-606, 750-625/000-001)! General information (e.g., installation regulations) on explosion protection is available in the WAGO I/O System 750 manuals!			
	Supply Module; 24 VDC; Diagnostics; Intrinsically Safe	750-606		432
	Supply Module; 24 VDC; Intrinsically Safe	750-625/000-001		432
Filter Module 	The mixed operation of safe and conventional I/O modules streamlines system configuration. For increased electromagnetic immunity (EMC standard), WAGO offers compact power supply filter modules (see Section 7.10). Specific power supply features must be considered, which are described in the corresponding manuals.			
	Field Supply Filter (Surge); 24 VDC; Higher Isolation	750-624/020-000		466
	Supply Filter; 24 VDC; Higher Isolation	750-626/020-000		468

Position Paper CB24I of the German Electrical and Electronic Manufacturer's Association (ZVEI)

7.8

Safe digital interfaces differ from conventional digital interfaces through higher safety testing for both inputs and outputs. They include dynamic digital interfaces of different characteristics and functions. At first glance, the combination of inputs to outputs results in a variety of possible variants due to the different applications. For this reason, ZVEI has issued the Position Paper CB24i in order to increase functional safety and simplify engineering processes.

The purpose of this paper is to:

- describe terms
- define characteristics of interface types
- specify product information (technical data) per interface type to be supplied by the manufacturer.

This paper provides a technical description for all interface types. No safety-related assessment is made.

The variety of possible combinations was divided into just four interface types (see right).

For both interface types C and D, four "performance" classes are also available to match the time requirements of the test pulses.

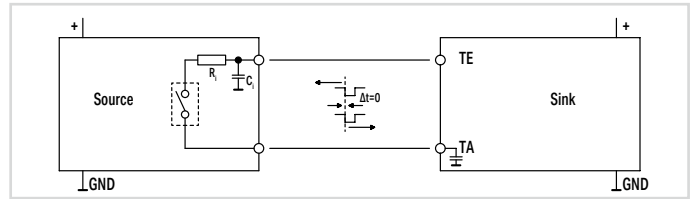

Interface type A

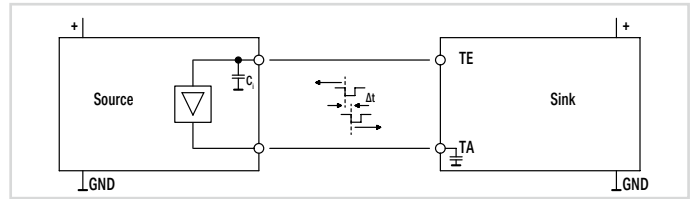

Interface type B

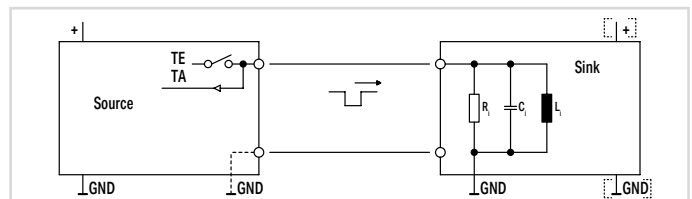

Interface type C

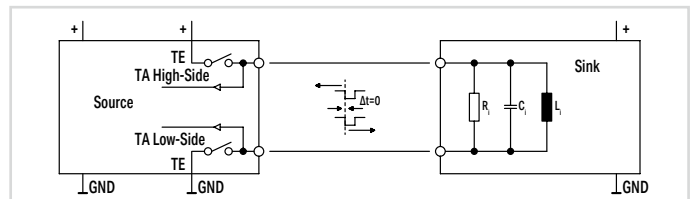

Interface type D

The identifying key has the following structure:

Source/Sink	Interface type (and class)	Additional measures "M"	Sink/Source	Suitable interface type (and class)	Suitable interface type (and class)	Suitable interface type (and class)
-------------	----------------------------	-------------------------	-------------	-------------------------------------	-------------------------------------	-------------------------------------

The first position describes the interface type and, if necessary, the class of the product. The second position indicates if additional measures are necessary. Next, the interface type suitable for this product is specified. Up to three interface types can be indicated. A row can only contain interface types of the same kind. Depending on the product, several identifying keys may also be used.

Examples:

a) Manufacturer information for a source of interface type C/class 2 (e.g., sensor):

Source	C2		Sink	C1	C2	
--------	----	--	------	----	----	--

Explanation: In this case, a source of type C2 is compatible with a sink of type C1 and also with a sink of type C2.

b) Manufacturer information for a sink of interface type C/class 2 (e.g., safety PLC):

Sink	C2		Source	C2	C3	
------	----	--	--------	----	----	--

Explanation: In this case, a sink of type C2 is compatible with a source of type C2 and also with a sink of type C3.

c) Manufacturer information for a sink of interface type A (e.g., safety evaluation unit):

Sink	A	M	Source	A		
------	---	---	--------	---	--	--

Explanation: In this case, a sink of type A is compatible with a source of type A subject to "M" additional measures.

Complete information can be found in the ZVEI Position Paper CB24i. This position paper is available for download in German and English via the ZVEI website.

Classification of Binary 24 V Interfaces with Testing in the Field of Functional Safety per ZVEI Position Paper CB24I

WAGO – Functional Safety		Identifying Key per ZVEI Position Paper CB24I										
Description	Item No.	Source/Sink	Interface type	Additional measures "M"	Measures			Sink/Source	Suitable interface type	Suitable interface type	Suitable interface type	Suitable interface type
					Parameterize filter time/short circuit test	Parameterize/switch off test pulse duration	Protected wiring					
Inputs												
Safe 4-channel digital input; 24 VDC; PROFIsafe	750-661/000-004	Sink	A	-				Source	A	-	-	-
		Sink	C0	M	x			Source	C0	C1	C2	C3
Safe 4-channel digital input; 24 VDC; PROFIsafe	753-661/000-004	Sink	A	-				Source	A	-	-	-
		Sink	C0	M	x			Source	C0	C1	C2	C3
Safe 8-channel digital input; 24 VDC; PROFIsafe	750-662/000-004	Sink	A	-				Source	A	-	-	-
		Sink	C0	M	x			Source	C0	C1	C2	C3
Safe 8-channel digital input; 24 VDC; PROFIsafe	753-662/000-004	Sink	A	-				Source	A	-	-	-
		Sink	C0	M	x			Source	C0	C1	C2	C3
Inputs/outputs												
Safe 4/2 channel digital input/output; 24 VDC; 10 A; PROFIsafe	750-666/000-004	Sink	A	-				Source	A	-	-	-
		Sink	C0	M	x			Source	C0	C1	C2	C3
		Source	C0	M		x		Sink	C0	C1	C2	C3
		Source	D0	M		x		Sink	D0	D1	D2	D3
Safe 4/4 channel digital input/output; 24 VDC; 2 A; PROFIsafe	750-667/000-004	Sink	A	-				Source	A	-	-	-
		Sink	C0	M	x			Source	C0	C1	C2	C3
		Source	C0	M		x		Sink	C0	C1	C2	C3
		Source	D0	M		x		Sink	D0	D1	D2	D3
Safe 4/4 channel digital input/output; 24 VDC; 2 A; PROFIsafe	753-667/000-004	Sink	A	-				Source	A	-	-	-
		Sink	C0	M	x			Source	C0	C1	C2	C3
		Source	C0	M		x		Sink	C0	C1	C2	C3
		Source	D0	M		x		Sink	D0	D1	D2	D3
Safe 4/4 channel digital input/relay output; 48 VAC/ 60 VDC; 6 A; PROFIsafe V2.0 iPar	750-669/000-003	Sink	A	-				Source	A	-	-	-
		Sink	C0	M	x			Source	C0	C1	C2	C3
		Source	A	-				Sink	A	-	-	-
		Source	C0	M			x	Sink	C0	C1	C2	C3
Intrinsically Safe Input												
Intrinsically safe 4-channel digital input; 24 VDC; PROFIsafe V2.0 iPar	750-663/000-003	Sink	A	-				Source	A	-	-	-
		Sink	C0	M	x			Source	C0	C1	C2	C3

Classification of Binary 24 V Interfaces with Testing in the Field of Functional Safety per ZVEI Position Paper CB241

7.8

Interface Type A – Sink		Item: 75x-661/000-004; 75x-662/000-004; 750-666/000-004; 75x-667/000-004; 750-669/000-003			Item: 750-663/000-003		
Parameters	Min.	Typ. (24 V)	Max.	Min.	Typ. (24 V)	Max.	
Input current I_i (in the ON state)	>2 mA	-	<9 mA	>2 mA	3 mA	<9 mA	
Output voltage U_i	Field power supply -0.2 V	-	-	Field power supply -0.2 V	-	-	
Input capacitance C_i	-	-	12 nF	-	-	12 nF	
Additional measure "M"	Parameterize filter time; activate short circuit test			Parameterize filter time; activate short circuit test			

Interface Type C – Sink, Class C0		Item: 75x-661/000-004; 75x-662/000-004; 750-666/000-004; 75x-667/000-004; 750-669/000-003			Item: 750-663/000-003		
Parameters	Min.	Typ. (24 V)	Max.	Min.	Typ. (24 V)	Max.	
Test pulse duration t_i	0.5 ms	-	200 ms	0.5 ms	-	200 ms	
Test pulse interval T	18 ms	42 ms	1230 ms	18 ms	42 ms	1230 ms	
Input resistance R	-	3.6 k Ω	8.5 k Ω	-	2.4 k Ω	8.5 k Ω	
Input capacitance C_L	-	-	12 nF	-	-	12 nF	
Inductance L_L	-	-	-	-	-	-	
Additional measure "M"	Parameterize filter time Deactivate short circuit test			Parameterize filter time Deactivate short circuit test			

Interface Type C – Sink, Class C1		Item: 75x-661/000-004; 75x-662/000-004; 750-666/000-004; 75x-667/000-004; 750-669/000-003			Item: 750-663/000-003		
Parameters	Min.	Typ. (24 V)	Max.	Min.	Typ. (24 V)	Max.	
Test pulse duration t_i	2 ms	-	200 ms	2 ms	-	200 ms	
Test pulse interval T	18 ms	42 ms	1230 ms	18 ms	42 ms	1230 ms	
Input resistance R	-	3.6 k Ω	8.5 k Ω	-	2.4 k Ω	8.5 k Ω	
Input capacitance C_L	-	-	12 nF	-	-	12 nF	
Inductance L_L	-	-	-	-	-	-	
Additional measure "M"	Parameterize filter time to at least 2 ms Deactivate short circuit test			Parameterize filter time to at least 2 ms Deactivate short circuit test			

Interface Type C – Sink, Class C2		Item: 75x-661/000-004; 75x-662/000-004; 750-666/000-004; 75x-667/000-004; 750-669/000-003			Item: 750-663/000-003		
Parameters	Min.	Typ. (24 V)	Max.	Min.	Typ. (24 V)	Max.	
Test pulse duration t_i	1 ms	-	200 ms	1 ms	-	200 ms	
Test pulse interval T	18 ms	42 ms	1230 ms	18 ms	42 ms	1230 ms	
Input resistance R	-	3.6 k Ω	8.5 k Ω	-	2.4 k Ω	8.5 k Ω	
Input capacitance C_L	-	-	12 nF	-	-	12 nF	
Inductance L_L	-	-	-	-	-	-	
Additional measure "M"	Parameterize filter time to at least 1 ms Deactivate short circuit test			Parameterize filter time to at least 1 ms Deactivate short circuit test			

Interface Type C – Sink, Class C3		Item: 75x-661/000-004; 75x-662/000-004; 750-666/000-004; 75x-667/000-004; 750-669/000-003			Item: 750-663/000-003		
Parameters	Min.	Typ. (24 V)	Max.	Min.	Typ. (24 V)	Max.	
Test pulse duration t_i	0.5 ms	-	200 ms	0.5 ms	-	200 ms	
Test pulse interval T	18 ms	42 ms	1230 ms	18 ms	42 ms	1230 ms	
Input resistance R	-	3.6 k Ω	8.5 k Ω	-	2.4 k Ω	8.5 k Ω	
Input capacitance C_L	-	-	12 nF	-	-	12 nF	
Inductance L_L	-	-	-	-	-	-	
Additional measure "M"	Parameterize filter time to at least 0.5 ms Deactivate short circuit test			Parameterize filter time to at least 0.5 ms Deactivate short circuit test			

Classification of Binary 24 V Interfaces with Testing in the Field of Functional Safety per ZVEI Position Paper CB24I

Interface Type A – Source		Item: 750-669/000-003		
Parameters	Min.	Typ.	Max.	
Switching current I_i	3 mA	-	6 A per contact	
Switching voltage U_i	10 V	-	60 VDC / 48 VAC	
Internal resistance R_i (in the switched state)	-	-	100 mΩ	
Load capacitance C_L	-	-	-	
Load inductance L_L	-	-	1.2 H	
Potential-free	Yes			

Interface Type C – Source, Class C0		Item: 750-666/000-004			Item: 75x-667/000-004		
Parameters	Min.	Typ.	Max.	Min.	Typ.	Max.	
Test pulse duration t_i	2 ms	-	500 ms	1 ms	-	500 ms	
Leakage current I Leakage of the output in the OFF state	-	-	<1 mA	-	-	1.2 mA	
Nominal current I_N of the output in the ON state	-	-	10 A	20 mA	2 A	2.4 A	
Capacitive load C_L	-	-	10,000 μF	-	-	2.2 μF	
Inductive load L_L	-	-	1.2 H	-	-	1.2 H	
Additional measure "M"	Parameterize test pulse duration Parameterize output tolerance time			Parameterize test pulse duration			

Interface Type D – Source, Class D0		Item: 750-666/000-004			Item: 75x-667/000-004		
Parameters	Min.	Typ.	Max.	Min.	Typ.	Max.	
Test pulse duration t_i	2 ms	-	500 ms	1 ms	-	500 ms	
Leakage current I Leakage of the output in the OFF state	-	-	<1 mA	-	-	1.2 mA	
Nominal current I_N of the output in the ON state	-	-	10 A	20 mA	2 A	2.4 A	
Capacitive load C_L	-	-	10,000 μF	-	-	2.2 μF	
Inductive load L_L	-	-	1.2 H	-	-	1.2 H	
Additional measure "M"	Parameterize test pulse duration Parameterize output tolerance time			Parameterize test pulse duration			

Interface Type D – Source, Class D1		Item: 75x-667/000-004		
Parameters	Min.	Typ.	Max.	
Test pulse duration t_i	-	-	1 ms	
Leakage current I Leakage of the output in the OFF state	-	-	1.2 mA	
Nominal current I_N of the output in the ON state	20 mA	2 A	2.4 A	
Capacitive load C_L	-	-	2.2 μF	
Inductive load L_L	-	-	1.2 H	
Additional measure "M"	Parameterize test pulse duration to 1 ms			

Interface Type D – Source, Class D1, D2, D3		Item: 750-666/000-004			Item: 75x-667/000-004		
Parameters	Min.	Typ.	Max.	Min.	Typ.	Max.	
Test pulse duration t_i	-	-	-	-	-	-	
Leakage current I Leakage of the output in the OFF state	-	-	<1 mA	-	-	1.2 mA	
Nominal current I_N of the output in the ON state	20 mA	2 A	10 A	20 mA	2 A	2.4 A	
Capacitive load C_L	-	-	10,000 μF	-	-	2.2 μF	
Inductive load L_L	-	-	1.2 H	-	-	1.2 H	
Additional measure "M"	Parameterize test pulse duration to 0 ms (off) Parameterize output tolerance time Program safety application for automatic test: Switch off the output once every 8 h Parameterize output configuration			Parameterize test pulse duration to 0 ms (off) Program safety application for automatic test: Switch off the output once every 8 h			

Functional safety ► Digital input

7.8



750-661/000-004

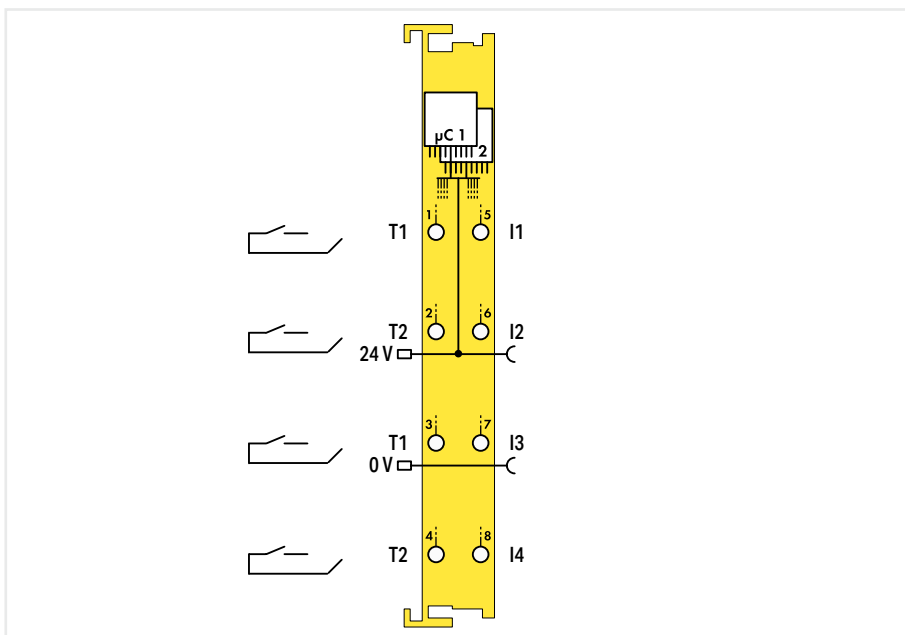

Item description	Safe 4-channel digital input; 24 VDC; PROFIsafe	
Version	Standard	pluggable
Item no.	750-661/000-004	753-661/000-004
Order Text	4FDI 24V PROFIsafe	4FDI 24V PROFIsafe
Technical data	fixed	pluggable
Pluggable connector		
Number of digital inputs	4	
Achievable safety classes	SIL 3; Category 4, PLe (two-channel); SIL 2; Category 2; PLd (one-channel)	
Interface types according to ZVEI (inputs)	Drain; A, C0, C1, C2, C3	
Protocols	PROFIsafe V2.6 (PROFINET)	
Configuration options	PROFIsafe address adjustable via DIP switch or engineering software	
Sensor connection	4 x (Fail-safe input with test pulse)	
Input characteristic	clock sensitive	
Input characteristic	Type 1 per IEC 61131	
Input current per channel for signal (1) typ.	3 mA	
Signal frequency (max.)	50 Hz	
Output current per channel	0.1 A	
Supply voltage (field)	24 VSELV/PELV DC (-25 ... +30 %); via power jumper contacts (power supply via blade contact; transmission via spring contact)	
Current consumption (5 V system supply)	120 mA	
Ambient temperature (operation)	0 ... +55 °C	
Dimensions W x H x D	(12 x 100 x 67.8) mm	
Functional safety	IEC 61508-1 ... -7; EN ISO 13849-1; EN 62061	
Approvals	CE; Marine; OrdLoc/HazLoc	
For data sheet and additional information, see:	wago.com/750-661/000-004	wago.com/753-661/000-004
Accessories	Item no.	Item no.
Plug; Safety	-	753-120

Support for iPar servers allows automatic parameter restoration when replacing an I/O module.

Functional safety ▶ Digital input



750-662/000-004

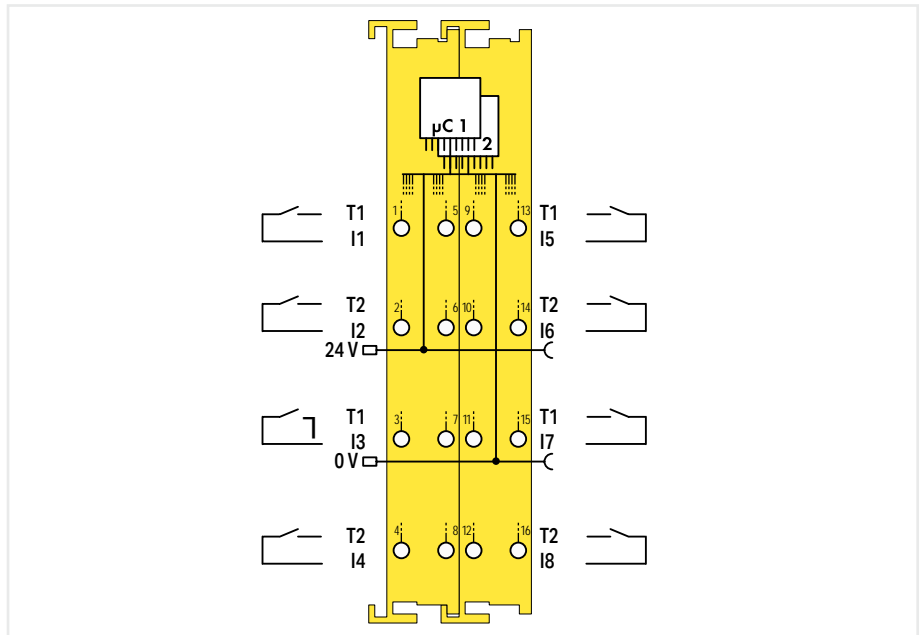

Item description
Version
Item no.
Order Text

Safe 8-channel digital input; 24 VDC; PROFIsafe	
Standard	pluggable
750-662/000-004	753-662/000-004
8FDI 24V PROFIsafe	8FDI 24V PROFIsafe

Technical data
Pluggable connector
Number of digital inputs
Achievable safety classes
Interface types according to ZVEI (inputs)
Protocols
Configuration options
Sensor connection
Input characteristic
Input characteristic
Input current per channel for signal (1) typ.
Signal frequency (max.)
Output current per channel
Supply voltage (field)
Current consumption (5 V system supply)
Ambient temperature (operation)
Dimensions W x H x D
Functional safety
Safety standards
Approvals
For data sheet and additional information, see:
Accessories

	fixed	pluggable
	8	
	SIL 3; Category 4, PL _e (two-channel); SIL 2; Category 2; PL _d (one-channel)	
	Drain; A, C0, C1, C2, C3	
	PROFIsafe V2.6 (PROFINET)	
	PROFIsafe address adjustable via DIP switch or engineering software	
	8 x (Fail-safe input with test pulse)	
	clock sensitive	
	Type 1 per IEC 61131	
	3 mA	
	50 Hz	
	0.1 A	
	24 VSELV/PELV DC (-25 ... +30 %); via power jumper contacts (power supply via blade contact; transmission via spring contact)	
	120 mA	
	0 ... +55 °C	
	(24 x 100 x 67.8) mm	
	IEC 61508-1 ... -7; EN ISO 13849-1; EN 62061	
	CE; Marine; OrdLoc/HazLoc	
	wago.com/750-662/000-004	wago.com/753-662/000-004
Item no.		Item no.

Plug; Safety

- 753-120

Support for iPar servers allows automatic parameter restoration when replacing an I/O module.

Functional safety ► Digital input; Digital output

7.8



750-666/000-004

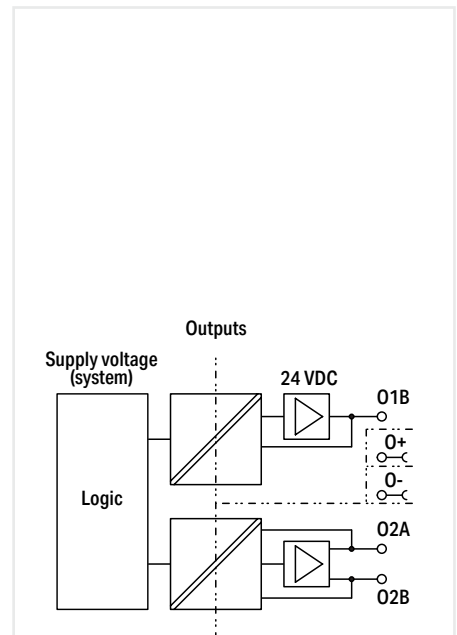
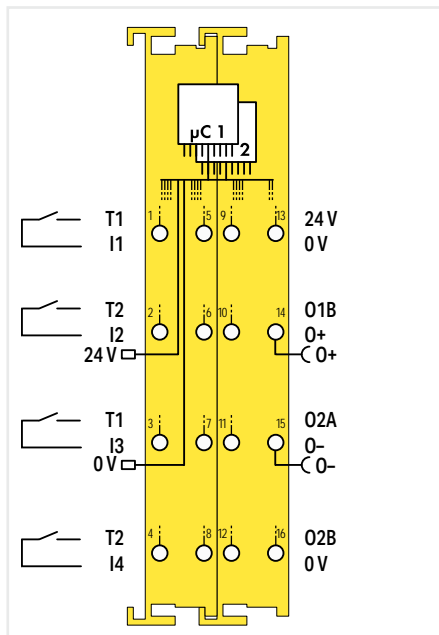

Item description	Safe 4/2 channel digital input/output; 24 VDC; 10 A; PROFIsafe
Version	Standard
Item no.	750-666/000-004
Order Text	4FDI/2FDO 24V/10A PROFIsafe
Technical data	
Pluggable connector	fixed
Number of digital inputs	4
Achievable safety classes	SIL 3; Category 4, PL _e (two-channel); SIL 2; Category 2; PL _d (one-channel)
Interface types according to ZVEI (inputs)	Drain; A, C0, C1, C2, C3
Protocols	PROFIsafe V2.6 (PROFINET)
Configuration options	PROFIsafe address adjustable via DIP switch or engineering software
Sensor connection	4 x (Fail-safe input with test pulse)
Input characteristic	clock sensitive
Input characteristic	Type 1 per IEC 61131
Input current per channel for signal (1) typ.	3 mA
Signal frequency (max.)	50 Hz
Number of digital outputs	2
Interface types according to ZVEI (outputs)	Source; C0, C1, C2, C3, D0, D1, D2, D3
Output circuit design	Power outputs
Actuator connection	2 x (fail-safe output with test pulse)
Output current per channel	10 A
Output current	short-circuit-protected
Output current (module)	20 A
Switching frequency (max.)	50 Hz; Resistive load
Switching frequency (max.) (2)	0.1 Hz; Inductive load
Switching frequency (max.) (3)	0.1 Hz; Capacitive load
Supply voltage (field)	24 VSELV/PELV DC (-25 ... +30 %); via power jumper contacts (power supply via blade contact)
Current consumption (5 V system supply)	120 mA
Ambient temperature (operation)	0 ... +55 °C
Dimensions W x H x D	(24 x 100 x 67.8) mm
Functional safety	
Safety standards	IEC 61508-1 ... -7; EN ISO 13849-1; EN 62061
Approvals	CE; Marine; OrdLoc/HazLoc
For data sheet and additional information, see:	wago.com/750-666/000-004

This module enables a fail-safe 2-channel switch-off (single failure protection) when the power outputs are used in a bipolar configuration. If a fail-safe 1-channel switch-off is adequate, two independent switching channels are available.

The module is capable of safely shutting off the supply voltage of entire actuator groups which are connected to the standard modules arranged to the right. The 2-channel circuit types P-M and P-P, as well as the 1-channel circuit types P, P or P, M are available.

Support for iPar servers allows automatic parameter restoration when replacing an I/O module.

Functional safety ▶ Digital input; Digital output



750-667/000-004

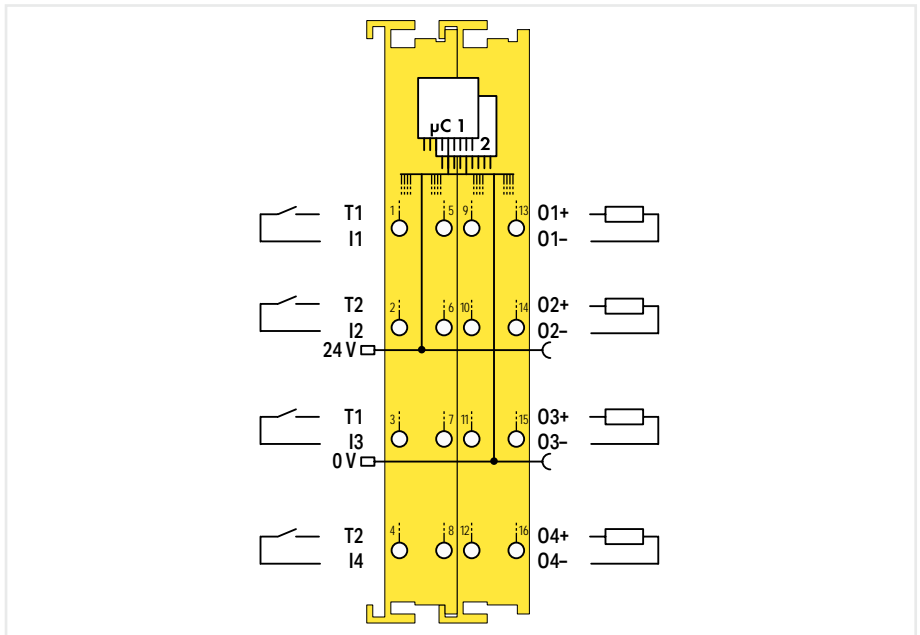

Item description	Safe 4/4 channel digital input/output; 24 VDC; 2 A; PROFIsafe	
Version	Standard	pluggable
Item no.	750-667/000-004	753-667/000-004
Order Text	4FDI/4FDO 24V/2A PROFIsafe	4FDI/4FDO 24V/2A PROFIsafe

Technical data	fixed	pluggable
Pluggable connector		
Number of digital inputs	4	
Achievable safety classes	SIL 3; Category 4, PL _e (two-channel); SIL 2; Category 2; PL _d (one-channel)	
Interface types according to ZVEI (inputs)	Drain; A, C0, C1, C2, C3	
Protocols	PROFIsafe V2.6 (PROFINET)	
Configuration options	PROFIsafe address adjustable via DIP switch or engineering software	
Sensor connection	4 x (Fail-safe input with test pulse)	
Input characteristic	clock sensitive	
Input characteristic	Type 1 per IEC 61131	
Input current per channel for signal (1) typ.	3 mA	
Signal frequency (max.)	50 Hz	
Number of digital outputs	4	
Interface types according to ZVEI (outputs)	Source; C0, C1, C2, C3, D0, D1, D2, D3	
Output circuit design	Power outputs	
Actuator connection	4 x (fail-safe output with test pulse)	
Output current per channel	2 A	
Output current	short-circuit-protected	
Output current (module)	8 A	
Capacitive load for each channel	O1 ... O4; 47 µF	
Switching frequency (max.)	50 Hz; Resistive load	
Switching frequency (max.) (2)	0.1 Hz; Inductive load	
Supply voltage (field)	24 VSELV/PELV DC (-25 ... +20 %); via power jumper contacts (power supply via blade contact; transmission via spring contact)	
Current consumption (5 V system supply)	120 mA	
Ambient temperature (operation)	0 ... +55 °C	
Dimensions W x H x D	(24 x 100 x 67.8) mm	
Functional safety		
Safety standards	IEC 61508-1 ... -7; EN ISO 13849-1; EN 62061	
Approvals	CE; Marine; OrdLoc/HazLoc	
For data sheet and additional information, see:	wago.com/750-667/000-004	wago.com/753-667/000-004
Accessories	Item no.	Item no.
Plug; Safety	-	753-120

Support for iPar servers allows automatic parameter restoration when replacing an I/O module.

Functional safety ► Digital input; Relay output

7.8



750-669/000-003

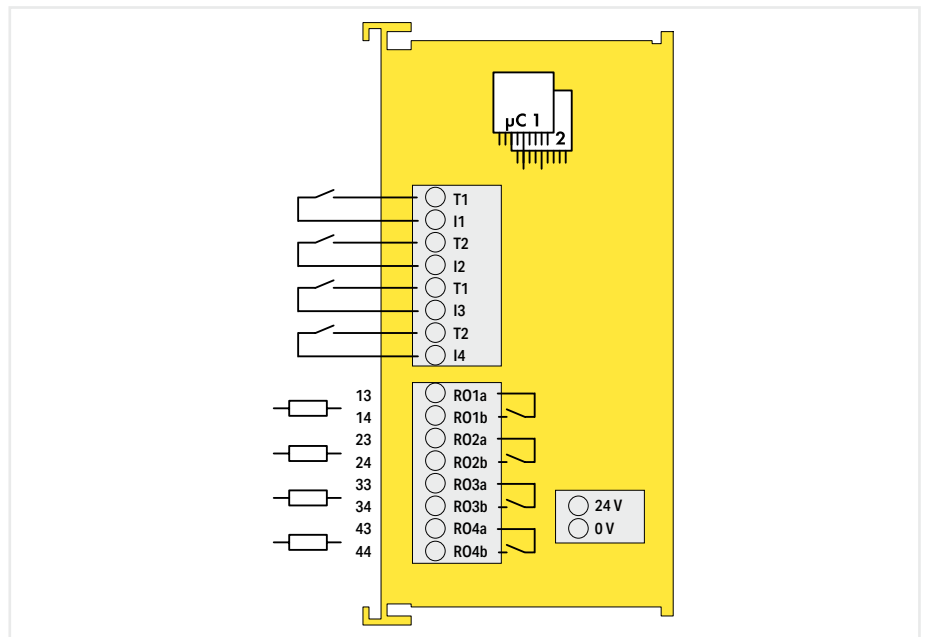

Item description	Safe Digital Input/Relay Output, 4/4 Channels; 48 VAC/60 VDC; 6 A; PROFIsafe V 2.0 iPar
Item no.	750-669/000-003
Order Text	4FDI/4FRO; 48VAC/ 60VDC; 6A; PROFIsafe V2 iPar
Technical data	
Number of digital inputs	4
Achievable safety classes	SIL 3; Category 4, PL e
Protocols	PROFIsafe V2
Configuration options	PROFIsafe address adjustable via DIP switch or engineering software
Sensor connection	4 x (Fail-safe input with test pulse)
Input characteristic	clock sensitive
Input characteristic	Type 1
Input current per channel for signal (1) typ.	2.2 mA
Signal frequency (max.)	50 Hz
Number of digital outputs	4
Output circuit design	Relay outputs
Actuator connection	4 x (fail-safe output with test pulse)
Switching voltage range	5 ... 60 VDC (SELV/PELV); 5 ... 48 VAC
Isolation voltage	Relay outputs: 48 VAC, 60 VDC
Switching current (note)	Switching current range compatible with the WAGO 75x-66x/000-003 PROFIsafe I/O Module
Output current per channel	6 A
Output current (module)	24 A
Switching delay	50 ms
Supply voltage (system and sensor)	24 VDC(-25 ... +30 %)
Supply voltage (field)	24 VDC; via pluggable connector (Push-in CAGE CLAMP® connection)
Current consumption (5 V system supply)	145 mA
Isolation	500 V system/field
Ambient temperature (operation)	0 ... +55 °C
Dimensions W x H x D	(48 x 100 x 69.8) mm
Functional safety	
Safety standards	IEC 61508-1 ... -7; EN ISO 13849-1; EN 62061
Approvals	CE; OrdLoc/HazLoc; ATEX/IECEx
For data sheet and additional information, see:	wago.com/750-669/000-003

Support for iPar servers allows automatic parameter restoration when replacing an I/O module.

Functional safety ▶ Analog input



750-668/000-004

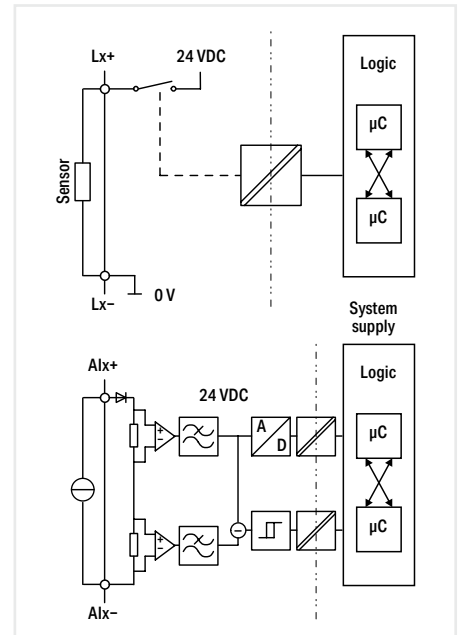
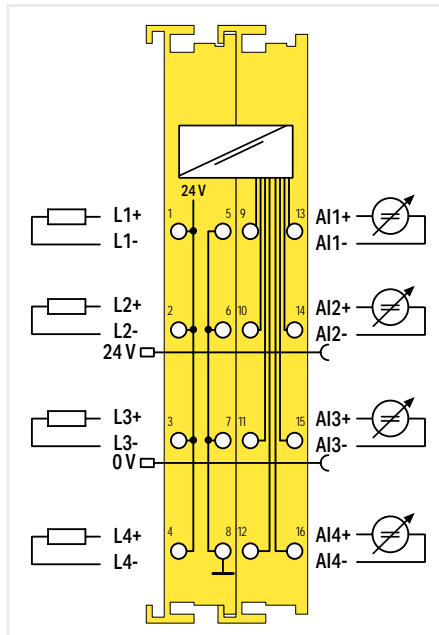

Item description	Safe Analog Input, 4 Channels; 0/4 ... 20 mA; Differential Input; PROFIsafe	
Version	Standard	pluggable
Item no.	750-668/000-004	753-668/000-004
Order Text	4FAI 0/4-20 mA Diff PROFIsafe	4FAI 0/4-20 mA Diff PROFIsafe
Technical data		
Number of analog inputs	4	
Achievable safety classes	SIL 3; Category 4, PL _e (two-channel); SIL 2; Category 2; PL _d (one-channel)	
Protocols	PROFIsafe V2	
Configuration options	PROFIsafe address adjustable via DIP switch or engineering software	
Sensor connection	4 x (2-wire, 3-wire, 4-wire)	
Signal characteristics	Differential	
Resolution [bit]	16 bits	
Load impedance	300 Ω	
Common-mode voltage (max.)	60 V	
Noise rejection at sampling frequency	38 dB	
Measurement error (reference temperature)	25 °C	
Measurement error, deviation (max.) from the upper-range value	0.05 %	
Temperature error (max.) of the upper-range value	0.006 %/K	
Output current per channel	1.5 A	
Output current (module)	1.5 A	
Current carrying capacity	40 mA	
Sensor supply	Outputs L1 ... L4	
Supply voltage (field)	24 VSELV/PELV DC (-15 ... +30 %); via power jumper contacts (power supply via blade contact; transmission via spring contact)	
Current consumption (5 V system supply)	120 mA	
Isolation	500 V system/field	
Ambient temperature (operation)	0 ... +55 °C	
Dimensions W x H x D	(24 x 100 x 67.8) mm	(24 x 100 x 69) mm
Functional safety	IEC 61508-1 ... -7; EN ISO 13849-1; EN 62061	
Safety standards	CE; Marine; OrdLoc/HazLoc; ATEX/IECEx	
Approvals	wago.com/750-668/000-004	
For data sheet and additional information, see:	wago.com/750-668/000-004	wago.com/753-668/000-004
Accessories	Item no.	Item no.
Plug; Safety	-	753-120

Functional safety ► Intrinsically safe modules (Ex i); Digital input

7.8



750-663/000-003

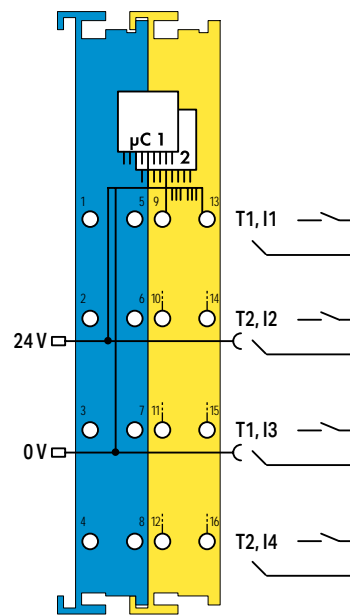

Item description	Intrinsically Safe 4-Channel Digital Input; 24 VDC; PROFIsafe V 2.0 iPar
Version	intrinsically safe
Item no.	750-663/000-003
Order Text	4F-Ex i DI; 24 VDC; PROFIsafe V2 iPar
Technical data	
Number of digital inputs	4
Protocols	PROFIsafe V2
Configuration options	PROFIsafe address adjustable via DIP switch or engineering software
Sensor connection	4 x (Fail-safe input with test pulse)
Input characteristic	clock sensitive
Input characteristic	Type 1
Input filter	0 ... 200 ms (parameterizable in steps)
Input current per channel for signal (1) typ.	3 mA
Signal frequency (max.)	50 Hz
Short-circuit current	≤ 25 mA
Output current per channel	0.05 A
Supply voltage (field)	24 VDC; (Ex i power supply: $U_o = \text{max. } 27.3 \text{ V}$); via power jumper contacts (power supply via blade contact; transmission via spring contact)
Current consumption (5 V system supply)	145 mA
Isolation	300 VAC system/field
Ambient temperature (operation)	0 ... +55 °C
Dimensions W x H x D	(24 x 100 x 67.8) mm
Functional safety	
Achievable risk reduction	SIL 3 per IEC 61508; SIL 3 per IEC 61511; SIL 3 per IEC 62061; Cat. 4, PL e per EN ISO 13849
Safety standards	IEC 61508; IEC 62061; EN ISO 13849; IEC 61511
Explosion protection	
Safety-relevant data (circuit)	$U_o = 27.3 \text{ V}$; $I_o = 23 \text{ mA}$; $P_o = 157 \text{ mW}$; linear characteristic curve
Reactances Ex ia IIC	$L_o = 61 \text{ mH}$; $C_o = 64 \text{ nF}$
Reactances Ex ia IIB	$L_o = 100 \text{ mH}$; $C_o = 552 \text{ nF}$
Reactances Ex ia IIA	$L_o = 100 \text{ mH}$; $C_o = 2.28 \text{ } \mu\text{F}$
Reactances Ex ia I	$L_o = 100 \text{ mH}$; $C_o = 2.95 \text{ } \mu\text{F}$
Reactances (note)	Reactances without accounting for the concurrence of capacitance (C_o) and inductance (L_o)
Ex standard	EN IEC 60079-0, -7, -11
Approvals	CE; Marine; OrdLoc/HazLoc/AEx; ATEX/IECEX; INMETRO
Marking	ATEX/IECEX: II 3 (1) G Ex ec [ia Ga] IIC T4 Gc; II (1) D [Ex ia Da] IIIC; I (M1) [Ex ia Ma] I
For data sheet and additional information, see:	wago.com/750-663/000-003

This module combines intrinsic safety with functional safety and was specifically developed for reliable acquisition from potential-free, contact-based emergency stop switches, safety interlock switches, mode selectors and safety sensors that are located in hazardous environments.

Thus, safety functions with fail-safe sensors from Ex Zones 0 and 1 can be implemented.

Support for iPar servers allows automatic parameter restoration when replacing an I/O module.

Intrinsically Safe Modules Ex i



Specialty Housing

Dimensions W x H x D	48 x 100 x 70.9 mm
Depth from upper edge of DIN-rail	63.7 mm
Connection technology	CAGE CLAMP®
Conductor cross-section	0.08 ... 1.5 mm ² / 28 ... 16 AWG
Strip length	5 ... 6 mm / 0.22 inch

Housing Design (750 Series)

Dimensions W x H x D	12 or 24 x 100 x 67.8 mm
Depth from upper edge of DIN-rail	60.6 mm
Connection technology	CAGE CLAMP®
Conductor cross-section	0.08 ... 2.5 mm ² / 28 ... 14 AWG
Strip length	8 ... 9 mm / 0.33 inch

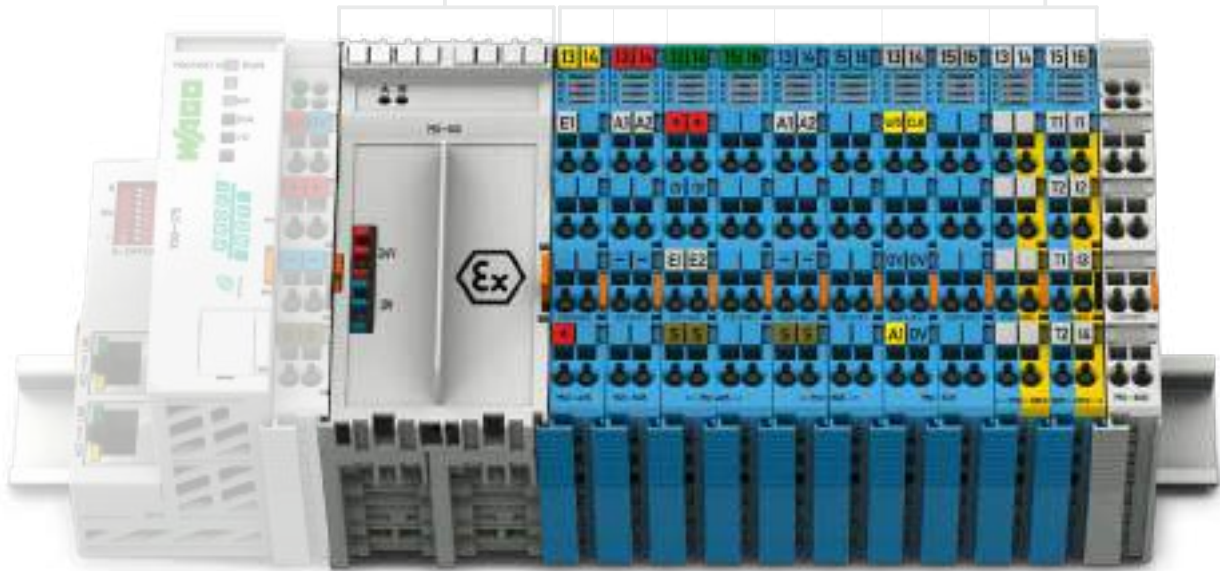

Use in Hazardous Areas

In many plants across the chemical and petro-chemical industries, as well as in the production and process automation sectors, installations are operated that process explosive gas- or dust-air mixtures. This is why electrical equipment must be explosion-proof in order to avoid injuries to personnel and damage to facilities.

The modules within the WAGO I/O System 750 are designed for use in both non-hazardous and hazardous areas. The direct application of fieldbus technology in potentially explosive areas is typically resource-intensive. When used in hazardous areas of Zone 2/22, the I/O System 750 offers a safe, easy and economical connection to the sensors/actuators of Zones 0/20 and 1/21. The "blue" Ex i I/O modules were specially developed for this purpose. They form an intrinsically safe section that can be integrated into a standard fieldbus node, offering all the advantages of state-of-the-art fieldbus technology. The WAGO I/O System 750 is also approved for mining applications.

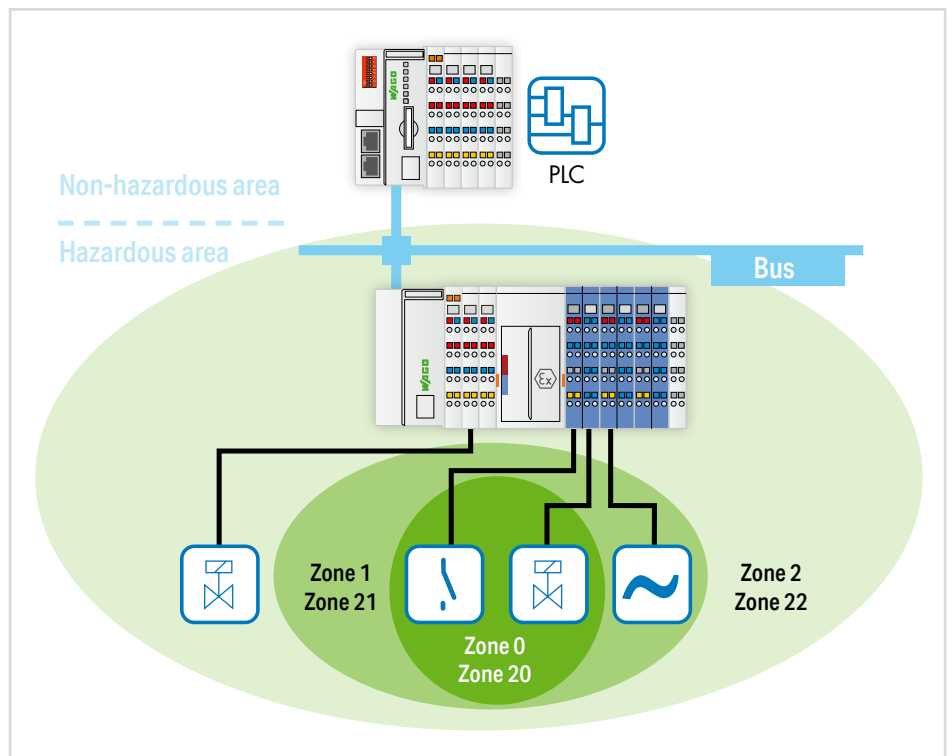

I/O System – 750 and 753 Series, Intrinsically Safe Modules Ex i

Contents

Function	Description	Item Number	Page
Power Supply Ex i	Supply Module; 24 VDC; Diagnostics; Intrinsically Safe	750-606*	432
	Supply Module; 24 VDC; Intrinsically Safe	750-625/000-001	432
Digital Input Ex i for Proximity Sensors per EN 60947-5-6	1-Channel Digital Input; NAMUR; Intrinsically Safe	750-435	433
	2-Channel Digital Input; NAMUR; Intrinsically Safe	750-438	434
	Intrinsically Safe 4-Channel Digital Input; 24 VDC; PROFIsafe V 2.0 iPar	750-663/000-003	428
	8-Channel Digital Input; NAMUR; Intrinsically Safe	750-439*	435
Digital Output Ex i	2-Channel Digital Output; 24 VDC; Intrinsically Safe	750-535*	436
	4-Channel Digital Output; 24 VDC; Valve; Intrinsically Safe	750-539	437
	2-Channel Relay Output; Changeover Contact; Potential-Free; Intrinsically Safe	750-538	438
Analog Input Ex i	2-Channel Analog Input; 4 ... 20 mA; Intrinsically Safe	750-485	439
	4-Channel Analog Input; 0/4 ... 20 mA; NAMUR NE43; Intrinsically Safe	750-486*	440
	2-Channel Analog Input; 4 ... 20 mA HART; Intrinsically Safe	750-484*	441
	2-Channel Analog Input; 4 ... 20 mA HART; NAMUR NE43; Intrinsically Safe	750-484/000-001	442
	4-Channel Analog Input; RTD/TC; Intrinsically Safe	750-489	443
Analog Output Ex i	2-Channel Analog Output; 0 ... 20 mA; Intrinsically Safe	750-585*	444
	2-Channel Analog Output; 4 ... 20 mA; Intrinsically Safe	750-586	445
Function Module Ex i	Up/Down Counter; Intrinsically Safe	750-633*	446
*This module is also available as a variant of the 750 XTR Series.		See Section 8	



I/O System –
750 XTR Series

Intrinsically safe modules (Ex i) ▶ Supply module

7.9



750-625/000-001

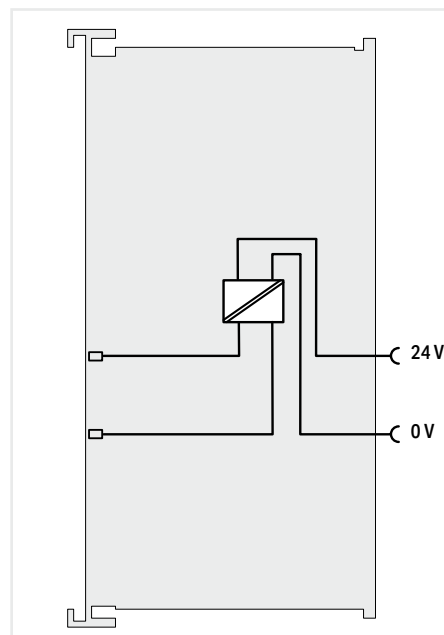
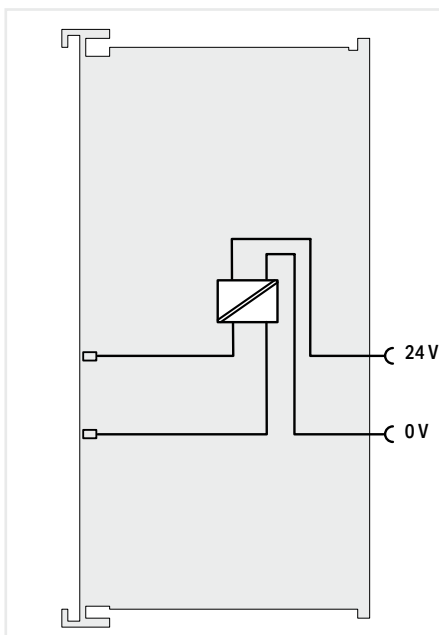

Item description
Version
Item no.
Order Text

Power Supply; 24 VDC
intrinsically safe
750-625/000-001
Power Supply; 24 VDC; Ex i

Power Supply; 24 VDC; Diagnostics
Diagnostics; intrinsically safe
750-606
Power Supply; 24 VDC; Diagn; Ex i

Technical data

Current consumption (5 V system supply)
Input voltage (note)
Supply voltage (field)

7.5 mA
24 VDC (-25 % ... +30 %)
24 VDC (-25 ... +30 %); (Adjacent Ex i modules are supplied with $U_o = \text{max. } 27.3 \text{ V}$); via power jumper contacts (power supply via CAGE CLAMP® connection; transmission via spring contact)

7.5 mA
24 VDC (-25 % ... +30 %)
24 VDC (-25 ... +30 %); (Adjacent Ex i modules are supplied with $U_o = \text{max. } 27.3 \text{ V}$); via power jumper contacts (power supply via CAGE CLAMP® connection; transmission via spring contact)

Current carrying capacity (power jumper contacts)

Fuse

Data width

Ambient temperature (operation)

Dimensions W x H x D

Explosion protection

Power supply (input)

Power supply (output)

1 A
electronic
-
0 ... +55 °C
(48 x 100 x 70.9) mm

1 A
electronic
2 bits (input voltage failure, fuse triggered)
0 ... +55 °C
(48 x 100 x 70.9) mm

Ex standard

Approvals

Marking

For data sheet and additional information, see:

$U_n = 24 \text{ VDC} (-25 \% \dots +30 \%)$; $P_{\text{max.}} = 29 \text{ W}$; $U_m = 253 \text{ V}$ $U_o = 26.8 \text{ V}$ (safe voltage per IEC 60079-11, protection level ia); $U_n = 24 \text{ V} \pm 0.3 \text{ V}$, $I_n = 1 \text{ A}$ EN IEC 60079-0, -7, -11 CE; Marine; OrdLoc/HazLoc/AEx; ATEX/IECEX; INMETRO ATEX/IECEX: II 3G Ex ec IIC T4 Gc wago.com/750-625/000-001

$U_n = 24 \text{ VDC} (-25 \% \dots +30 \%)$; $P_{\text{max.}} = 29 \text{ W}$; $U_m = 253 \text{ V}$ $U_o = 26.8 \text{ V}$ (safe voltage per IEC 60079-11, protection level ia); $U_n = 24 \text{ V} \pm 0.3 \text{ V}$, $I_n = 1 \text{ A}$ EN IEC 60079-0, -7, -11 CE; Marine; OrdLoc/HazLoc/AEx; ATEX/IECEX; INMETRO ATEX/IECEX: II 3G Ex ec IIC T4 Gc wago.com/750-606

The supply modules monitor the voltage supply of the downstream intrinsically safe segment and separate the intrinsically safe from the non-intrinsically safe section of the I/O system. The input and output sides are electrically isolated from each other.

Note: If, due to load conditions, more than one supply module is required per station, four spacer modules (750-616) must be placed between the intrinsically safe sections.

General information (e.g., installation regulations) on explosion protection is available in the WAGO I/O System 750 manuals!

The supply modules monitor the voltage supply of the downstream intrinsically safe segment and separate the intrinsically safe from the non-intrinsically safe section of the I/O system. The input and output sides are electrically isolated from each other.

Note: If, due to load conditions, more than one supply module is required per station, four spacer modules (750-616) must be placed between the intrinsically safe sections.

General information (e.g., installation regulations) on explosion protection is available in the WAGO I/O System 750 manuals!

Intrinsically safe modules (Ex i) ▶ Digital input



750-435

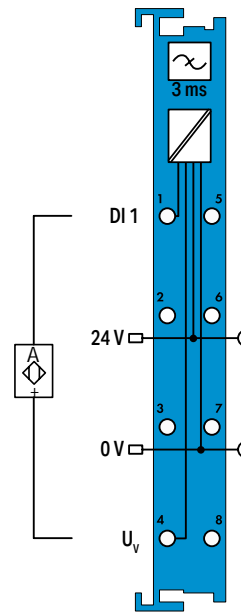

Item description
Version
Item no.
Order Text

1-Channel Digital Input; NAMUR

intrinsically safe

750-435

1DI; NAMUR; Ex i

Technical data
Number of digital inputs
Signal type
Sensor connection
Input characteristic
Input filter (digital)
Open-circuit voltage
Diagnostics
Supply voltage (sensor)
Supply voltage (field)
Current consumption, field supply (module with no external load)
Current consumption (5 V system supply)
Input data width (internal) max.
Data width
Isolation
Ambient temperature (operation)
Dimensions W x H x D
Explosion protection
Safety-relevant data (circuit)
Reactances Ex ia IIC
Reactances Ex ia IIB
Reactances Ex ia IIA
Reactances Ex ia I
Reactances (note)
Ex standard
Approvals
Marking

1
NAMUR
1 x (2-wire)
high-side switching
3 ms
8.2 V
Short circuit, wire break
8.2 VDC; short-circuit-protected, each channel supplied separately
24 VDC; (Ex i power supply: $U_o = \max. 27.3 \text{ V}$); via power jumper contacts (power supply via blade contact; transmission via spring contact)
13 mA
2.5 mA
2 bits
2-bit input: 1-bit status, 1-bit error (short circuit/wire break)
300 VAC system/field
0 ... +55 °C
(12 x 100 x 67.8) mm
$U_o = 12 \text{ V}$; $I_o = 16 \text{ mA}$; $P_o = 48 \text{ mW}$; linear characteristic curve
$L_o = 180 \text{ mH}$; $C_o = 1.4 \text{ }\mu\text{F}$
$L_o = 560 \text{ mH}$; $C_o = 9 \text{ }\mu\text{F}$
$L_o = 900 \text{ mH}$; $C_o = 36 \text{ }\mu\text{F}$
$L_o = 1 \text{ H}$; $C_o = 38 \text{ }\mu\text{F}$
Reactances without accounting for the concurrence of capacitance (C_o) and inductance (L_o)
EN IEC 60079-0, -7, -11
CE; Marine; OrdLoc/HazLoc/AEx; ATEX/IECEx; INMETRO
ATEX/IECEx: II 3 (1) G Ex ec [ia Ga] IIC T4 Gc; II (1) D [Ex ia Da] IIC; I (M1) [Ex ia Ma] I
wago.com/750-435

For data sheet and additional information, see:

Intrinsically safe modules (Ex i) ► Digital input



750-438

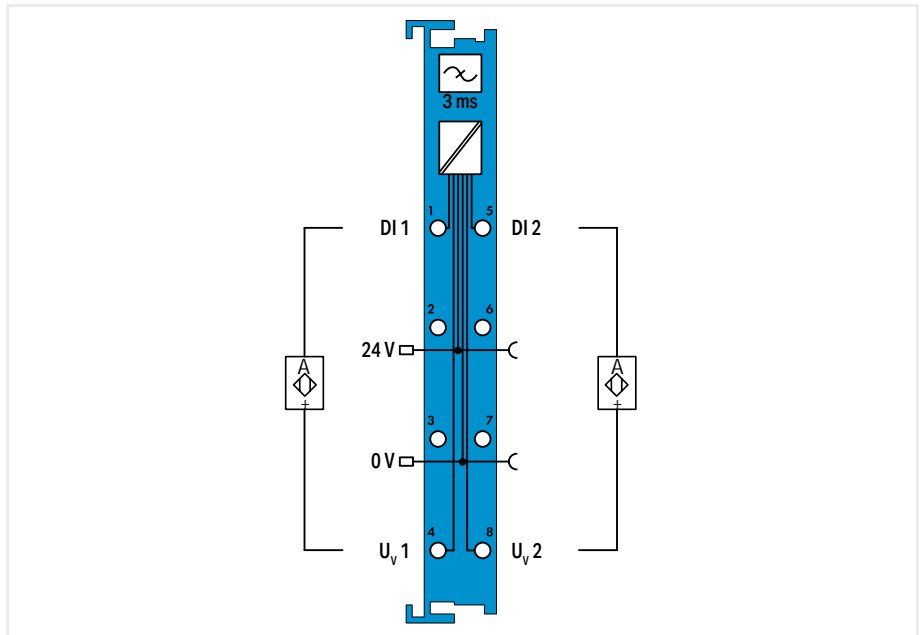

Item description	2-Channel Digital Input; NAMUR
Version	intrinsically safe
Item no.	750-438
Order Text	2DI; NAMUR; Ex i
Technical data	
Number of digital inputs	2
Signal type	NAMUR
Sensor connection	2 x (2-wire)
Input characteristic	high-side switching
Input filter (digital)	3 ms
Open-circuit voltage	8.2 V
Supply voltage (sensor)	8.2 VDC; short-circuit-protected, each channel supplied separately
Supply voltage (field)	24 VDC; (Ex i power supply: $U_o = \text{max. } 27.3 \text{ V}$); via power jumper contacts (power supply via blade contact; transmission via spring contact)
Current consumption, field supply (module with no external load)	16 mA
Current consumption (5 V system supply)	2.5 mA
Input data width (internal) max.	2 bits
Isolation	300 VAC system/field
Ambient temperature (operation)	0 ... +55 °C
Dimensions W x H x D	(12 x 100 x 67.8) mm
Explosion protection	
Safety-relevant data (circuit)	$U_o = 12 \text{ V}$; $I_o = 13.5 \text{ mA}$; $P_o = 40.5 \text{ mW}$; linear characteristic curve
Reactances Ex ia IIC	$L_o = 190 \text{ mH}$; $C_o = 1.4 \mu\text{F}$
Reactances Ex ia IIB	$L_o = 600 \text{ mH}$; $C_o = 9 \mu\text{F}$
Reactances Ex ia IIA	$L_o = 1 \text{ H}$; $C_o = 36 \mu\text{F}$
Reactances Ex ia I	$L_o = 1 \text{ H}$; $C_o = 38 \mu\text{F}$
Reactances (note)	Reactances without accounting for the concurrence of capacitance (C_o) and inductance (L_o)
Ex standard	EN IEC 60079-0, -7, -11
Approvals	CE; Marine; OrdLoc/HazLoc/AEx; ATEX/IECEX; INMETRO
Marking	ATEX/IECEX: II 3 (1) G Ex ec [ia Ga] IIC T4 Gc; II (1) D [Ex ia Da] IIIC; I (M1) [Ex ia Ma] I
For data sheet and additional information, see:	wago.com/750-438

Intrinsically safe modules (Ex i) ▶ Digital input



750-439

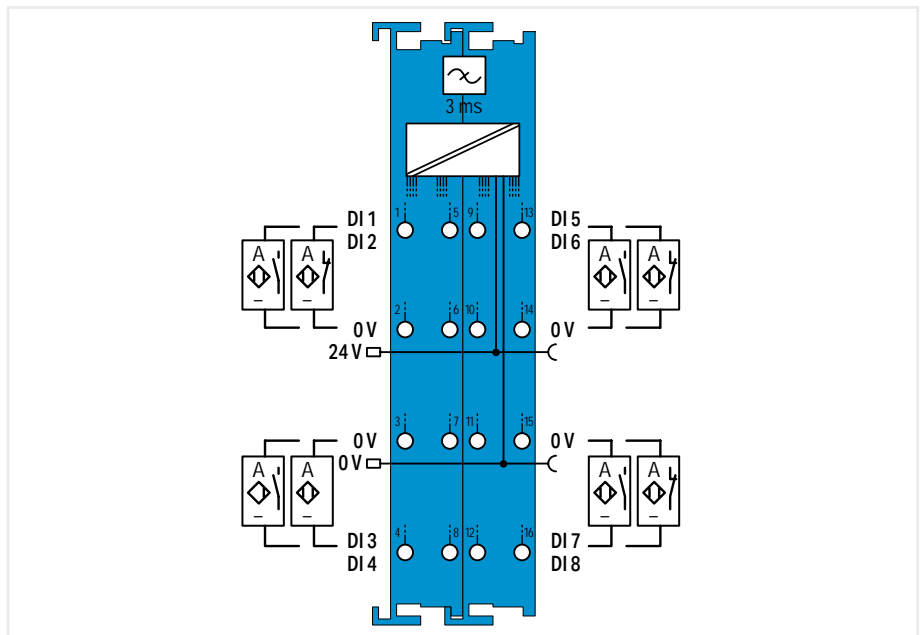

Item description	8-Channel Digital Input; NAMUR
Version	intrinsically safe
Item no.	750-439
Order Text	8DI; NAMUR; Ex i
Technical data	
Number of digital inputs	8
Signal type	NAMUR
Sensor connection	4 x (2-wire)
Input characteristic	high-side switching
Input filter (digital)	3 ms
Open-circuit voltage	8.2 V
Diagnostics	Short circuit; wire break (can be switched off)
Supply voltage (sensor)	8.2 VDC; short-circuit-protected, each channel supplied separately
Supply voltage (field)	24 VDC; (Ex i power supply: $U_0 = \max. 27.3 \text{ V}$); via power jumper contacts (power supply via blade contact; transmission via spring contact)
Current consumption, field supply (module with no external load)	11 mA
Current consumption (5 V system supply)	56 mA
Input data width (internal) max.	16 bits
Output data width (internal) max.	16 bits
Isolation	300 VAC system/field
Ambient temperature (operation)	0 ... +55 °C
Dimensions W x H x D	(24 x 100 x 67.8) mm
Explosion protection	
Safety-relevant data (circuit)	$U_0 = 11.76 \text{ V}$; $I_0 = 12.4 \text{ mA}$; $P_0 = 36.67 \text{ mW}$; linear characteristic curve
Reactances Ex ia IIC	$L_0 = 100 \text{ mH}$; $C_0 = 1 \mu\text{F}$
Reactances Ex ia IIB	$L_0 = 100 \text{ mH}$; $C_0 = 9.9 \mu\text{F}$
Reactances Ex ia IIA	$L_0 = 100 \text{ mH}$; $C_0 = 39 \mu\text{F}$
Reactances Ex ia I	$L_0 = 100 \text{ mH}$; $C_0 = 30 \mu\text{F}$
Reactances (note)	Reactances without accounting for the concurrence of capacitance (C_0) and inductance (L_0)
Ex standard	EN IEC 60079-0, -7, -11
Approvals	CE; Marine; OrdLoc/HazLoc/AEx; ATEX/IECEx; INMETRO
Marking	ATEX/IECEx: II 3 (1) G Ex ec [ia Ga] IIC T4 Gc; II (1) D [Ex ia Da] IIC; I (M1) [Ex ia Ma] I
For data sheet and additional information, see:	wago.com/750-439

The process image can be used to define the sensor type (break or make contact) as well as to switch off the diagnostics (e.g., if contact monitoring in order to suppress the LED diagnostics).

Intrinsically safe modules (Ex i) ► Digital output



750-535

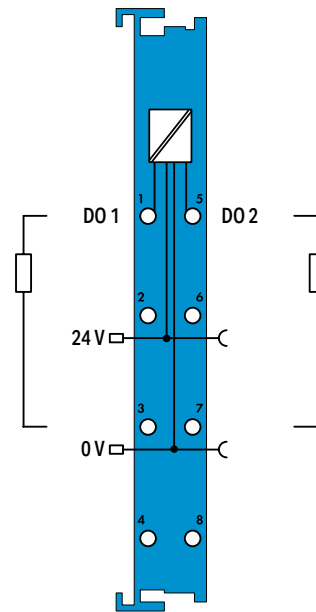

Item description	2-Channel Digital Output; 24 VDC
Version	intrinsically safe
Item no.	750-535
Order Text	2DO; 24 VDC; Ex i
Technical data	
Number of digital outputs	2
Signal type	Digital
Signal type (voltage)	24 VDC
Output characteristic	high-side switching
Load type	Resistive, inductive, lamp load
Actuator connection	2 x (2-wire)
Switching frequency (max.)	1 kHz
Supply voltage (field)	24 VDC; (Ex i power supply: $U_o = \text{max. } 27.3 \text{ V}$); via power jumper contacts (power supply via blade contact; transmission via spring contact)
Current consumption, field supply (module with no external load)	8.5 mA
Current consumption (5 V system supply)	7 mA
Output data width (internal) max.	2 bits
Isolation	300 VAC system/field
Ambient temperature (operation)	0 ... +55 °C
Dimensions W x H x D	(12 x 100 x 67.8) mm
Explosion protection	
Safety-relevant data (circuit)	$U_o = 27.3 \text{ V}$; $I_o = 106 \text{ mA}$; $P_o = 723 \text{ mW}$; linear characteristic curve
Reactances Ex ia IIC	$L_o = 3 \text{ mH}$; $C_o = 88 \text{ nF}$
Reactances Ex ia IIB	$L_o = 12 \text{ mH}$; $C_o = 680 \text{ nF}$
Reactances Ex ia IIA	$L_o = 18 \text{ mH}$; $C_o = 2.2 \mu\text{F}$
Reactances Ex ia I	$L_o = 20 \text{ mH}$; $C_o = 3.6 \mu\text{F}$
Reactances (note)	Reactances without accounting for the concurrence of capacitance (C_o) and inductance (L_o)
Ex standard	EN IEC 60079-0, -7, -11
Approvals	CE, Marine, OrdLoc/HazLoc/AEx, ATEX/IECEX, INMETRO
Marking	ATEX/IECEX: II 3 (1) G Ex ec [ia Ga] IIC T4 Gc; II (1) D [Ex ia Da] IIIC; I (M1) [Ex ia Ma] I
For data sheet and additional information, see:	wago.com/750-535

Intrinsically safe modules (Ex i) ▶ Digital output



750-539

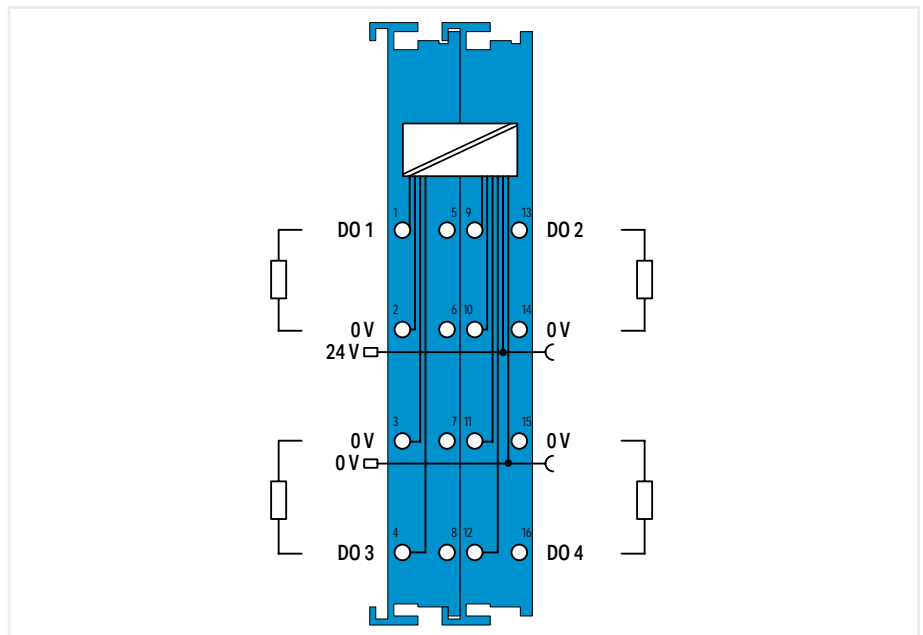

Item description	4-Channel Digital Output; 24 VDC; Valve
Version	intrinsically safe
Item no.	750-539
Order Text	4DO; 24 VDC; valve; Ex i
Technical data	
Number of digital outputs	4
Signal type	Digital
Signal type (voltage)	24 VDC
Output characteristic	high-side switching
Load type	Resistive, inductive, lamp load
Actuator connection	4 x (2-wire)
Switching frequency (max.)	100 Hz
Supply voltage (field)	24 VDC; (Ex i power supply: $U_0 = \max. 27.3 \text{ V}$); via power jumper contacts (power supply via blade contact; transmission via spring contact)
Current consumption, field supply (module with no external load)	10 mA
Current consumption (5 V system supply)	20 mA
Input data width (internal) max.	4 bits
Output data width (internal) max.	4 bits
Isolation	300 VAC system/field
Ambient temperature (operation)	0 ... +55 °C
Dimensions W x H x D	(24 x 100 x 67.8) mm
Explosion protection	
Safety-relevant data (circuit)	$U_0 = 27.3 \text{ V}$; $I_0 = 117.5 \text{ mA}$; $P_0 = 800.1 \text{ mW}$; linear characteristic curve
Reactances Ex ia IIC	$L_0 = 13 \text{ } \mu\text{H}$; $C_0 = 88 \text{ nF}$
Reactances Ex ia IIB	$L_0 = 8.1 \text{ mH}$; $C_0 = 683 \text{ nF}$
Reactances Ex ia IIA	$L_0 = 14 \text{ mH}$; $C_0 = 2.28 \text{ } \mu\text{F}$
Reactances Ex ia I	$L_0 = 21 \text{ mH}$; $C_0 = 540 \text{ nF}$
Reactances (note)	Reactances without accounting for the concurrence of capacitance (C_0) and inductance (L_0)
Ex standard	EN IEC 60079-0, -7, -11
Approvals	CE, Marine; OrdLoc/HazLoc; ATEX/IECEx; INMETRO
Marking	ATEX/IECEx: II 3 (1) G Ex ec [ia Ga] IIC T4 Gc; II (1) D [Ex ia Da] IIIC; I (M1) [Ex ia Ma] I
For data sheet and additional information, see:	wago.com/750-539

Intrinsically safe modules (Ex i) ► Digital output



750-538

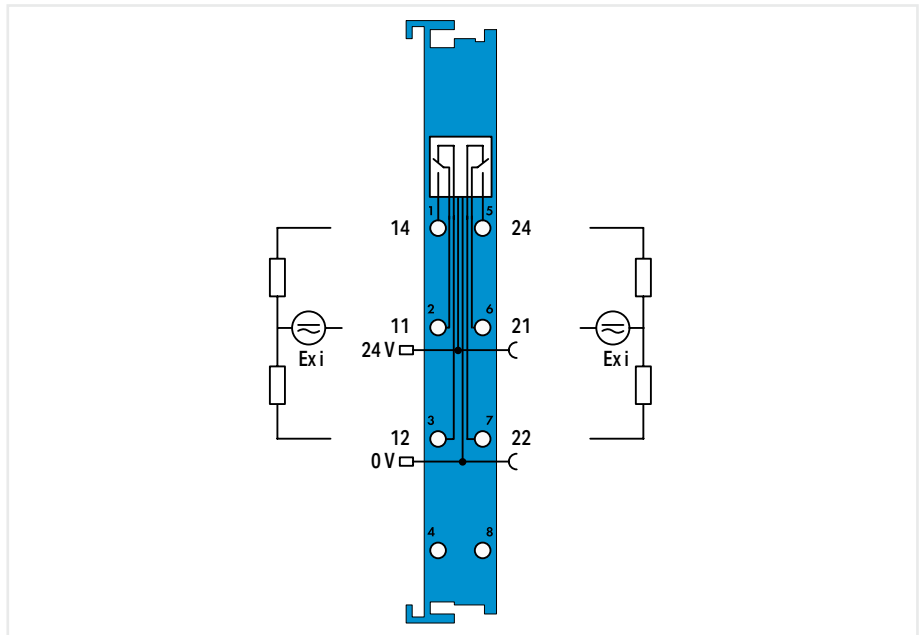

Item description	2-Channel Relay Output; Changeover contact; Potential-free
Version	intrinsically safe
Item no.	750-538
Order Text	2RO; 100 VAC/ 30 VDC; Pot-free; Relay2CO
Technical data	
Number of digital outputs	2
Signal type	Digital
Signal type (voltage)	100 VAC; 30 VDC
Output circuit design	2 changeover contacts; Relay
Output characteristic	potential-free
Switching current (max.)	0.5 A
Switching current (note)	0.5 A at 100 VAC; 1 A at 30 VDC
Load type	Resistive, inductive, lamp load
Actuator connection	2 x (2-wire)
Switching frequency (max.)	0.3 Hz
Supply voltage (field)	24 VDC; (Ex i power supply: $U_o = \text{max. } 27.3 \text{ V}$); via power jumper contacts (power supply via blade contact; transmission via spring contact)
Current consumption, field supply (module with no external load)	24 mA
Current consumption (5 V system supply)	26 mA
Output data width (internal) max.	2 bits
Isolation	300 VAC system/field
Ambient temperature (operation)	0 ... +55 °C
Dimensions W x H x D	(12 x 100 x 67.8) mm
Explosion protection	
Safety-relevant data (circuit)	Relay output: $U_i = 30 \text{ VDC}; I_i = 1 \text{ A}; P_i = 30 \text{ W}; U_i = 100 \text{ VAC}; I_i = 0.5 \text{ A}; P_i = 50 \text{ VA}; L_i = \text{negligibly small}; C_i = \text{negligibly small}$
Ex standard	EN IEC 60079-0, -7, -11
Approvals	CE; Marine; OrdLoc/HazLoc/AEx; ATEX/IECEX; INMETRO
Marking	ATEX/IECEX: II 3 (1) G Ex ec [ia Ga] IIC T4 Gc; II (1) D [Ex ia Da] IIIC; I (M1) [Ex ia Ma] I
For data sheet and additional information, see:	wago.com/750-538

Details on relay!

Both maximum switching current and voltage must comply with EN 60079-11.

Intrinsically safe modules (Ex i) ▶ Analog input ▶ 4 ... 20 mA



750-485

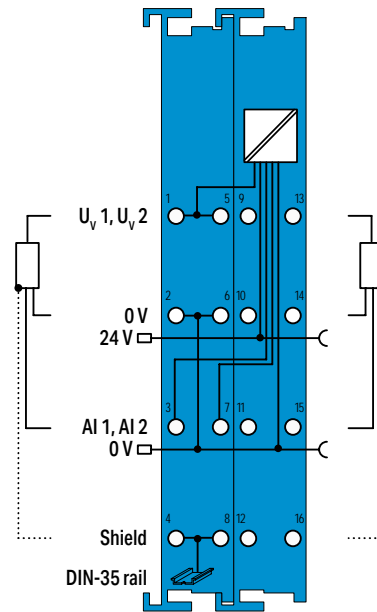

Item description	2-Channel Analog Input; 4 ... 20 mA
Version	intrinsically safe
Item no.	750-485
Order Text	2AI; 4-20mA; SE; Ex i
Technical data	
Number of analog inputs	2
Signal type	Current
Signal type (current)	4 ... 20 mADC
Sensor connection	2 x (3-wire)
Signal characteristics	Single-ended
Resolution [bit]	12 bits
Conversion time (typ.)	2 ms
Input resistance (max.)	100 Ω
Measurement error (reference temperature)	25 °C
Measurement error, deviation (max.) from the upper-range value	0.2 %
Temperature error (max.) of the upper-range value	0.01 %/K
Supply voltage (sensor)	16 VDC; Transmitter supply U_v at 20 mA
Supply voltage (field)	24 VDC; (Ex i power supply: $U_o = \text{max. } 27.3 \text{ V}$); via power jumper contacts (power supply via blade contact; transmission via spring contact)
Current consumption, field supply (module with no external load)	11 mA
Current consumption (5 V system supply)	31 mA
Data width	2 x 16-bit data; 2 x 8-bit control/status (optional)
Isolation	300 VAC system/field
Ambient temperature (operation)	0 ... +55 °C
Dimensions W x H x D	(24 x 100 x 67.8) mm
Explosion protection	
Safety-relevant data (circuit)	$U_o = 27.3 \text{ V}$; $I_o = 90 \text{ mA}$; $P_o = 0.61 \text{ W}$; linear characteristic curve
Reactances Ex ia IIC	$L_o = 5 \text{ mH}$; $C_o = 88 \text{ nF}$
Reactances Ex ia IIB	$L_o = 18 \text{ mH}$; $C_o = 680 \text{ nF}$
Reactances Ex ia IIA	$L_o = 40 \text{ mH}$; $C_o = 2.2 \text{ μF}$
Reactances Ex ia I	$L_o = 100 \text{ mH}$; $C_o = 3.5 \text{ μF}$
Reactances (note)	Reactances without accounting for the concurrence of capacitance (C_o) and inductance (L_o)
Ex standard	EN IEC 60079-0, -7, -11
Approvals	CE, Marine; OrdLoc/HazLoc/AEx; ATEX/IECEX; INMETRO
Marking	ATEX/IECEX: II 3 (1) G Ex ec [ia Ga] IIC T4 Gc; II (1) D [Ex ia Da] IIIC; I (M1) [Ex ia Ma] I
For data sheet and additional information, see:	wago.com/750-485

Intrinsically safe modules (Ex i) ▶ Analog input ▶ 0/4 ... 20 mA; NAMUR NE43

7.9



750-486

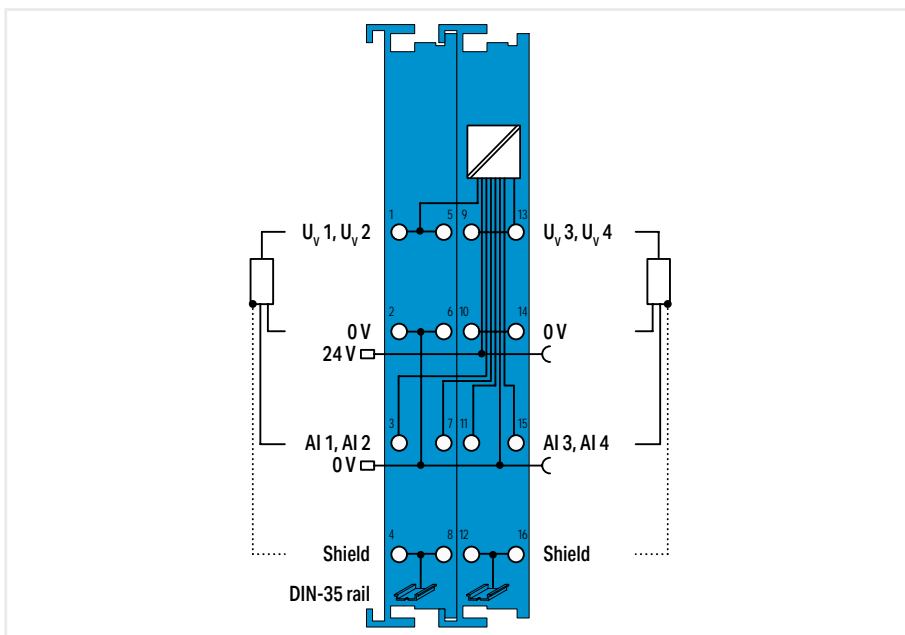

Item description	4-Channel Analog Input; 0/4 ... 20 mA; NAMUR NE43
Version	NAMUR NE43; intrinsically safe
Item no.	750-486
Order Text	4AI; 0/4-20mA; SE; 12bits; Diagn; Ex i
Technical data	
Number of analog inputs	4
Signal type	Current
Signal type (current)	0 ... 20 mADC; 4 ... 20 mADC
Sensor connection	2 x (3-wire)
Signal characteristics	Single-ended
Resolution [bit]	12 bits
Conversion time (typ.)	10 ms
Input resistance (max.)	200 Ω
Measurement error (reference temperature)	25 °C
Measurement error, deviation (max.) from the upper-range value	0.1 %
Temperature error (max.) of the upper-range value	0.01 %/K
Supply voltage (sensor)	15 VDC; Transmitter supply U_V at 20 mA
Supply voltage (field)	24 VDC; (Ex i power supply: $U_0 = \text{max. } 27.3 \text{ V}$); via power jumper contacts (power supply via blade contact; transmission via spring contact)
Current consumption, field supply (module with no external load)	19 mA
Current consumption (5 V system supply)	45 mA
Data width	4 x 16-bit data; 4 x 8-bit control/status (optional)
Isolation	300 VAC system/field
Ambient temperature (operation)	0 ... +55 °C
Dimensions W x H x D	(24 x 100 x 67.8) mm
Explosion protection	
Safety-relevant data (circuit)	$U_0 = 27.3 \text{ V}$; $I_0 = 98.4 \text{ mA}$; $P_0 = 0.672 \text{ W}$; linear characteristic curve
Reactances Ex ia IIC	$L_0 = 970 \mu\text{H}$; $C_0 = 88 \text{ nF}$
Reactances Ex ia IIB	$L_0 = 13 \text{ mH}$; $C_0 = 683 \text{ nF}$
Reactances Ex ia IIA	$L_0 = 22 \text{ mH}$; $C_0 = 2.28 \mu\text{F}$
Reactances Ex ia I	$L_0 = 31 \text{ mH}$; $C_0 = 3.6 \mu\text{F}$
Reactances (note)	Reactances without accounting for the concurrence of capacitance (C_0) and inductance (L_0)
Ex standard	EN IEC 60079-0, -7, -11
Approvals	CE; Marine; OrdLoc/HazLoc; ATEX/IECEX; INMETRO
Marking	ATEX/IECEX: II 3 (1) G Ex ec [ia Ga] IIC T4 Gc; II (1) D [Ex ia Da] IIIC; I (M1) [Ex ia Ma] I
For data sheet and additional information, see:	wago.com/750-486

Intrinsically safe modules (Ex i) ▶ Analog input ▶ 4 ... 20 mA HART



750-484

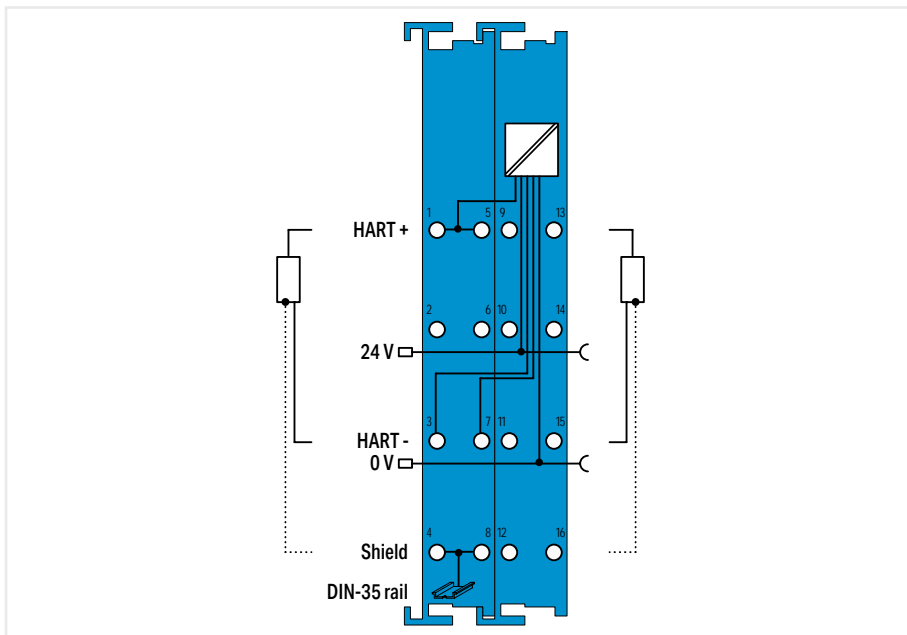

Item description	2-Channel Analog Input; 4 ... 20 mA HART
Version	intrinsically safe
Item no.	750-484
Order Text	2AI; 4-20mA HART; Ex i
Technical data	
Number of analog inputs	2
Signal type	Current
Signal type (current)	4 ... 20 mADC
Sensor connection	2 x (2-wire)
Input filter	parameterizable
Signal characteristics	Single-ended
Resolution [bit]	12 bits
Conversion time (typ.)	10 ms
Measurement error (reference temperature)	25 °C
Measurement error, deviation (max.) from the upper-range value	0.2 %
Temperature error (max.) of the upper-range value	0.01 %/K
Overvoltage protection	30 V, reverse polarity protected
Diagnostics	Wire break, measurement range overflow
Supply voltage (sensor)	16.5 VDC; Transmitter supply U_o at 20 mA
Supply voltage (field)	24 VDC; (Ex i power supply: $U_o = \max. 27.3 \text{ V}$); via power jumper contacts (power supply via blade contact; transmission via spring contact)
Current consumption, field supply (module with no external load)	26 mA
Current consumption (5 V system supply)	25 mA
Data width	2 x 2-byte data; 2 x 2-byte data + 2n x 4-byte data (n = number of dynamic variables); 2 x 2-byte data + 6-byte mailbox
Isolation	300 VAC system/field
Ambient temperature (operation)	0 ... +55 °C
Dimensions W x H x D	(24 x 100 x 67.8) mm
Explosion protection	
Safety-relevant data (circuit)	$U_o = 27.3 \text{ V}$; $I_o = 92.7 \text{ mA}$; $P_o = 630 \text{ mW}$; linear characteristic curve
Reactances Ex ia IIC	$L_o = 1.5 \text{ mH}$; $C_o = 87 \text{ nF}$
Reactances Ex ia IIB	$L_o = 15 \text{ mH}$; $C_o = 670 \text{ nF}$
Reactances Ex ia IIA	$L_o = 38 \text{ mH}$; $C_o = 2.2 \mu\text{F}$
Reactances Ex ia I	$L_o = 36 \text{ mH}$; $C_o = 3.49 \mu\text{F}$
Reactances (note)	Reactances without accounting for the concurrence of capacitance (C_o) and inductance (L_o)
Ex standard	EN IEC 60079-0, -7, -11
Approvals	CE; Marine; OrdLoc/HazLoc/AEx; ATEX/IECEx; INMETRO
Marking	ATEX/IECEx: II 3 (1) G Ex ec [ia Ga] IIC T4 Gc; II (1) D [Ex ia Da] IIC; I (M1) [Ex ia Ma] I
For data sheet and additional information, see:	wago.com/750-484

In addition to analog signal processing, this module offers optional HART communication for parameterizing or re-recording dynamic variables.

Intrinsically safe modules (Ex i) ▶ Analog input ▶ 4 ... 20 mA HART; NAMUR NE43



750-484/000-001

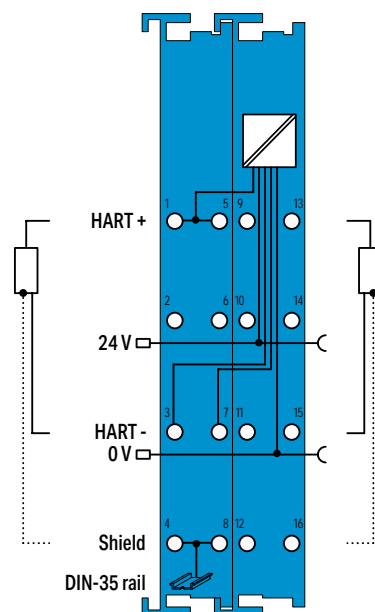

Item description	2-Channel Analog Input; 4 ... 20 mA HART; NAMUR NE43
Version	NAMUR NE43; intrinsically safe
Item no.	750-484/000-001
Order Text	2AI; 4-20mA HART; NE43; Ex i
Technical data	
Number of analog inputs	2
Signal type	Current
Signal type (current)	4 ... 20 mADC
Sensor connection	2 x (2-wire)
Input filter	parameterizable
Signal characteristics	Single-ended
Resolution [bit]	12 bits
Conversion time (typ.)	10 ms
Measurement error (reference temperature)	25 °C
Measurement error, deviation (max.) from the upper-range value	0.2 %
Temperature error (max.) of the upper-range value	0.01 %/K
Overvoltage protection	30 V, reverse polarity protected
Diagnostics	Wire break, measurement range overflow
Supply voltage (sensor)	16.5 VDC; Transmitter supply U_T at 20 mA
Supply voltage (field)	24 VDC; (Ex i power supply: $U_o = \text{max. } 27.3 \text{ V}$); via power jumper contacts (power supply via blade contact; transmission via spring contact)
Current consumption, field supply (module with no external load)	26 mA
Current consumption (5 V system supply)	25 mA
Data width	2 x 2-byte data; 2 x 2-byte data + 2n x 4-byte data (n = number of dynamic variables); 2 x 2-byte data + 6-byte mailbox
Isolation	300 VAC system/field
Ambient temperature (operation)	0 ... +55 °C
Dimensions W x H x D	(24 x 100 x 67.8) mm
Explosion protection	
Safety-relevant data (circuit)	$U_o = 27.3 \text{ V}$; $I_o = 92.7 \text{ mA}$; $P_o = 630 \text{ mW}$; linear characteristic curve
Reactances Ex ia IIC	$L_o = 1.5 \text{ mH}$; $C_o = 87 \text{ nF}$
Reactances Ex ia IIB	$L_o = 15 \text{ mH}$; $C_o = 670 \text{ nF}$
Reactances Ex ia IIA	$L_o = 38 \text{ mH}$; $C_o = 2.2 \text{ }\mu\text{F}$
Reactances Ex ia I	$L_o = 36 \text{ mH}$; $C_o = 3.49 \text{ }\mu\text{F}$
Reactances (note)	Reactances without accounting for the concurrence of capacitance (C_o) and inductance (L_o)
Ex standard	EN IEC 60079-0, -7, -11
Approvals	CE; Ⓢ- OrdLoc/HazLoc; Ⓢ ATEX/IECEX; INMETRO
Marking	ATEX/IECEX: II 3 (1) G Ex ec [ia Ga] IIC T4 Gc; II (1) D [Ex ia Da] IIIC; I (M1) [Ex ia Ma] I
For data sheet and additional information, see:	wago.com/750-484/000-001

In addition to analog signal processing, this module offers optional HART communication for parameterizing or recording dynamic variables.

Intrinsically safe modules (Ex i) ▶ Analog input ▶ Resistance sensors/thermocouples



750-489

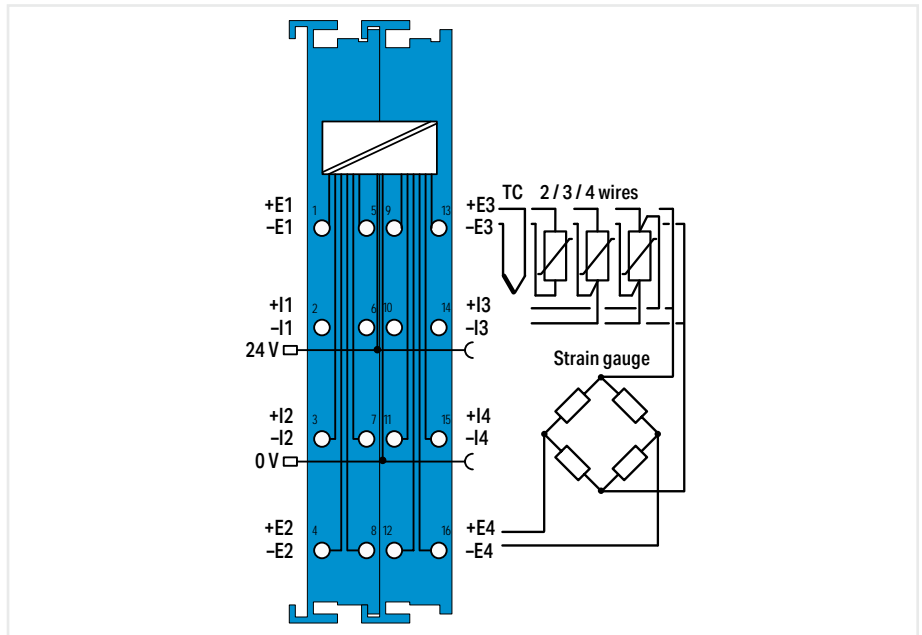

Item description	4-Channel Analog Input; RTD/TC
Version	intrinsically safe
Item no.	750-489
Order Text	4AI; RTD/TC; Ex i
Technical data	
Number of analog inputs	4
Signal type	Potentiometer positions; Thermocouple; Resistive temperature device; Resistors; mV encoder
Sensor connection	4 x (2-wire); RTD/R: 3-wire; 4-wire
Resolution (over entire range)	0.1 K of full scale value; 0.01 K of full scale value (restricted to -50 °C ... +150 °C)
Conversion time	≥10 ms/2 wires (per channel)*; ≥20 ms/3 wires, 4 wires (per channel)*; *for RTD/R; TC/U conversion time depends on module setting
Measurement error (25 °C)	In delivery state: ±0.2 % of the upper-range value (value achieved during calibration in operating environment 0 ≤ TA ≤ 55 °C); After user calibration: ±0.05 % of the upper-range value (only valid in the thermally stable operating state)
Temperature coefficient	±0.001 %/K of the upper-range value
Cold junction compensation	integrated
Supply voltage (field)	24 VDC; (Ex i power supply: U _o = max. 27.3 V); via power jumper contacts (power supply via blade contact; transmission via spring contact)
Current consumption, field supply (module with no external load)	120 mA
Current consumption (5 V system supply)	60 mA
Data width	4 x 16-bit data; 4 x 8-bit control/status (optional)
Isolation	per EN/IEC 60079-11: 300 VAC system/supply; per EN/UL 61010-2-201: 1200 VDC system/supply/channel
Ambient temperature (operation)	0 ... +55 °C
Dimensions W x H x D	(24 x 100 x 67.8) mm
Explosion protection	
Safety-relevant data (circuit)	U _o = 4 V; I _o = 13.46 mA; P _o = 13.46 mW; linear characteristic curve
Reactances Ex ia IIC	L _o = 0.19 H; C _o = 100 µF
Reactances Ex ia IIB	L _o = 0.78 H; C _o = 1000 µF
Reactances Ex ia IIA	L _o = 1.57 H; C _o = 1000 µF
Reactances Ex ia I	L _o = 2.57 H; C _o = 1000 µF
Reactances (note)	Reactances, if the internal inductance L _i or capacitance C _i (without cable) of the connected device is ≤1 % of the specified values.
Ex standard	EN IEC 60079-0, -7, -11
Approvals	CE; Marine; OrdLoc/HazLoc; ATEX/IECEx
Marking	ATEX/IECEx: II 3 (1) G Ex ec [ia Ga] IIC T4 Gc; II (1) D [Ex ia Da] IIIC; I (M1) [Ex ia Ma] I
For data sheet and additional information, see:	wago.com/750-489

Intrinsically safe modules (Ex i) ▶ Analog output ▶ 0 ... 20 mA



750-585

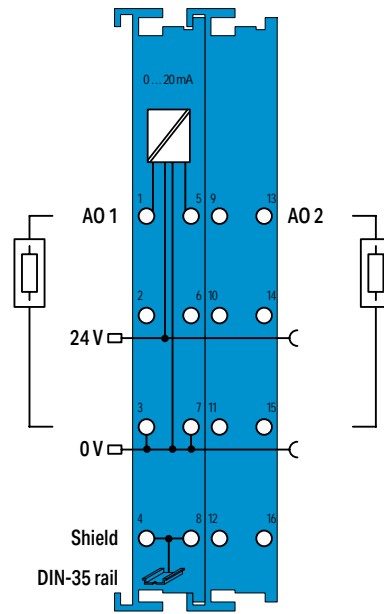

Item description	2-Channel Analog Output; 0 ... 20 mA
Version	intrinsically safe
Item no.	750-585
Order Text	2AO; 0-20mA; Ex i
Technical data	
Number of analog outputs	2
Signal type	Current
Signal type (current)	0 ... 20 mA DC
Signal characteristics	Single-ended
Load impedance (current output) max.	500 Ω
Resolution [bit]	12 bits
Conversion time (typ.)	2 ms
Output error, reference temperature	25 °C
Output error, deviation (max.) of the upper-range value	0.2 %
Temperature error (max.) of the output range value	0.01 %/K
Actuator connection	2 x (2-wire)
Supply voltage (field)	24 VDC; (Ex i power supply: $U_o = \text{max. } 27.3 \text{ V}$); via power jumper contacts (power supply via blade contact; transmission via spring contact)
Current consumption, field supply (module with no external load)	19 mA
Current consumption (5 V system supply)	21 mA
Data width	2 x 16-bit data
Isolation	300 VAC system/field
Ambient temperature (operation)	0 ... +55 °C
Dimensions W x H x D	(24 x 100 x 67.8) mm
Explosion protection	
Safety-relevant data (circuit)	$U_o = 27.3 \text{ V}$; $I_o = 57.5 \text{ mA}$; $P_o = 392 \text{ mW}$; linear characteristic curve
Reactances Ex ia IIC	$L_o = 11 \text{ mH}$; $C_o = 88 \text{ nF}$
Reactances Ex ia IIB	$L_o = 56 \text{ mH}$; $C_o = 680 \text{ nF}$
Reactances Ex ia IIA	$L_o = 90 \text{ mH}$; $C_o = 2.2 \text{ μF}$
Reactances Ex ia I	$L_o = 110 \text{ mH}$; $C_o = 3.5 \text{ μF}$
Reactances (note)	Reactances without accounting for the concurrence of capacitance (C_o) and inductance (L_o)
Ex standard	EN IEC 60079-0, -7, -11
Approvals	CE; Marine; OrdLoc/HazLoc/AEx; ATEX/IECEX; INMETRO
Marking	ATEX/IECEX: II 3 (1) G Ex ec [ia Ga] IIC T4 Gc; II (1) D [Ex ia Da] IIIC; I (M1) [Ex ia Ma] I
For data sheet and additional information, see:	wago.com/750-585

Intrinsically safe modules (Ex i) ▶ Analog output ▶ 4 ... 20 mA



750-586

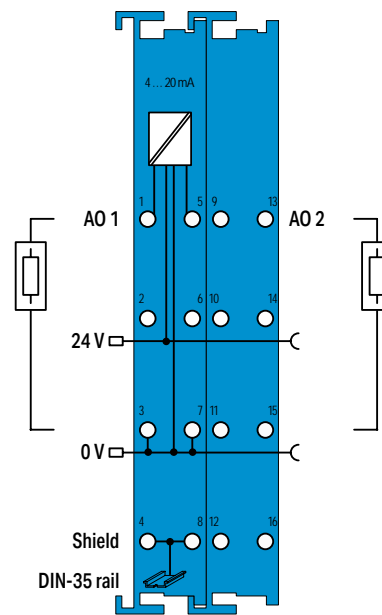

Item description	2-Channel Analog Output; 4 ... 20 mA
Version	intrinsically safe
Item no.	750-586
Order Text	2AO; 2-4-wire; Ex i
Technical data	
Number of analog outputs	2
Signal type	Current
Signal type (current)	4 ... 20 mA DC
Signal characteristics	Single-ended
Load impedance (current output) max.	500 Ω
Resolution [bit]	12 bits
Conversion time (typ.)	2 ms
Output error, reference temperature	25 °C
Output error, deviation (max.) of the upper-range value	0.2 %
Temperature error (max.) of the output range value	0.01 %/K
Actuator connection	2 x (2-wire)
Supply voltage (field)	24 VDC; (Ex i power supply: $U_0 = \text{max. } 27.3 \text{ V}$); via power jumper contacts (power supply via blade contact; transmission via spring contact)
Current consumption, field supply (module with no external load)	19 mA
Current consumption (5 V system supply)	21 mA
Data width	2 x 16-bit data
Isolation	300 VAC system/field
Ambient temperature (operation)	0 ... +55 °C
Dimensions W x H x D	(24 x 100 x 67.8) mm
Explosion protection	
Safety-relevant data (circuit)	$U_0 = 27.3 \text{ V}$; $I_0 = 57.5 \text{ mA}$; $P_0 = 392 \text{ mW}$; linear characteristic curve
Reactances Ex ia IIC	$L_0 = 11 \text{ mH}$; $C_0 = 88 \text{ nF}$
Reactances Ex ia IIB	$L_0 = 56 \text{ mH}$; $C_0 = 680 \text{ nF}$
Reactances Ex ia IIA	$L_0 = 90 \text{ mH}$; $C_0 = 2.2 \text{ μF}$
Reactances Ex ia I	$L_0 = 110 \text{ mH}$; $C_0 = 3.5 \text{ μF}$
Reactances (note)	Reactances without accounting for the concurrence of capacitance (C_0) and inductance (L_0)
Ex standard	EN IEC 60079-0, -7, -11
Approvals	CE; Marine; OrdLoc/HazLoc/AEx; ATEX/IECEx; INMETRO
Marking	ATEX/IECEx: II 3 (1) G Ex ec [ia Ga] IIC T4 Gc; II (1) D [Ex ia Da] IIIC; I (M1) [Ex ia Ma] I
For data sheet and additional information, see:	wago.com/750-586

Intrinsically safe modules (Ex i) ► Counter



750-633

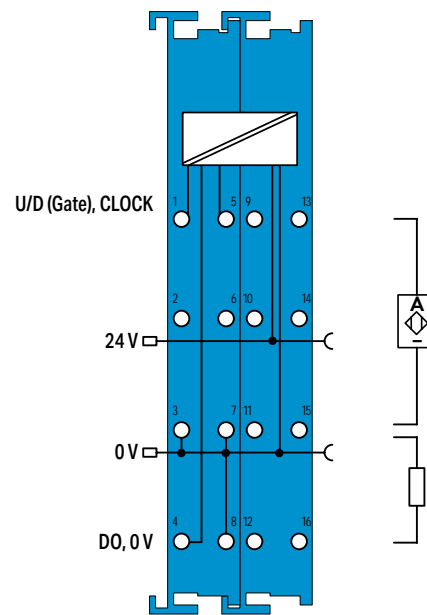

Item description	Up/Down Counter
Version	intrinsically safe
Item no.	750-633
Order Text	Up/Down Counter; Ex i
Technical data	
Number of counters	1
Number of digital outputs	1
Sensor supply U_v	8.2 V
Switching frequency	20 Hz ... 50 kHz
Counter depth	32 bits
Output voltage	24 VDC
Input filter	10 μ s
Input resistance (max.)	1000 Ω
Open-circuit voltage	8.2 V
Supply voltage (field)	24 VDC; (Ex i power supply: $U_o = \text{max. } 26.8 \text{ V}$); via power jumper contacts (power supply via blade contact; transmission via spring contact)
Current consumption, field supply (module with no external load)	31 mA
Current consumption (5 V system supply)	25 mA
Data width	1 x 32-bit data, 1 x 8-bit status/diagnostics
Isolation	300 VAC system/field
Ambient temperature (operation)	0 ... +55 $^{\circ}\text{C}$
Dimensions W x H x D	(24 x 100 x 67.8) mm
Explosion protection	
Safety data (input)	$U_o = 12 \text{ V}$; $I_o = 13.5 \text{ mA}$; $P_o = 40.5 \text{ mW}$; linear characteristic curve
Reactances of Ex ia IIC inputs	$L_o = 100 \text{ mH}$; $C_o = 1.4 \mu\text{F}$
Reactances of Ex ia IIB inputs	$L_o = 100 \text{ mH}$; $C_o = 9 \mu\text{F}$
Reactances of Ex ia IIA inputs	$L_o = 100 \text{ mH}$; $C_o = 36 \mu\text{F}$
Reactances of Ex ia I inputs	$L_o = 100 \text{ mH}$; $C_o = 38 \mu\text{F}$
Safety data (output)	$U_o = 26.8 \text{ V}$; $I_o = 96.7 \text{ mA}$; $P_o = 648 \text{ mW}$; linear characteristic curve
Reactances of Ex ia IIC output	$L_o = 0.5 \text{ mH}$; $C_o = 88 \text{ nF}$
Reactances of Ex ia IIB output	$L_o = 10 \text{ mH}$; $C_o = 683 \text{ nF}$
Reactances of Ex ia IIA output	$L_o = 18 \text{ mH}$; $C_o = 2.2 \mu\text{F}$
Reactances of Ex ia I output	$L_o = 26 \text{ mH}$; $C_o = 3.6 \mu\text{F}$
Reactances (note)	Reactances without accounting for the concurrence of capacitance (C_o) and inductance (L_o)
Ex standard	EN IEC 60079-0, -7, -11
Approvals	CE, Marine, OrdLoc/HazLoc/AEX; ATEX/IECEx; INMETRO
Marking	ATEX/IECEx: II 3 (1) G Ex ec [ia Ga] IIC T4 Gc; I (M1) [Ex ia Ma] I; II (1) D [Ex ia Da] IIIC
For data sheet and additional information, see:	wago.com/750-633

Supply/Segment Modules

Housing Design (750/753 Series)

Dimensions W x H x D	12 x 100 x 69.8 mm
Depth from upper edge of DIN rail	62.6 mm
Connection technology	CAGE CLAMP®
Conductor cross-section	0.08 ... 2.5 mm ² / 28 ... 14 AWG
Strip length	750 Series: 8 ... 9 mm / 0.33 inch 753 Series: 9 ... 10 mm / 0.37 inch

Housing Design (750 Series), with Push-in CAGE CLAMP® Connections (up to 16 connection points)

Dimensions W x H x D	12 x 100 x 69 mm
Depth from upper edge of DIN rail	61.8 mm
Connection technology	Push-in CAGE CLAMP®
Conductor cross-section	Solid: 0.08 ... 2.5 mm ² / 28 ... 16 AWG Fine-stranded: 0.25 ... 1.5 mm ² / 22 ... 16 AWG
Strip length	8 ... 9 mm / 0.33 inch

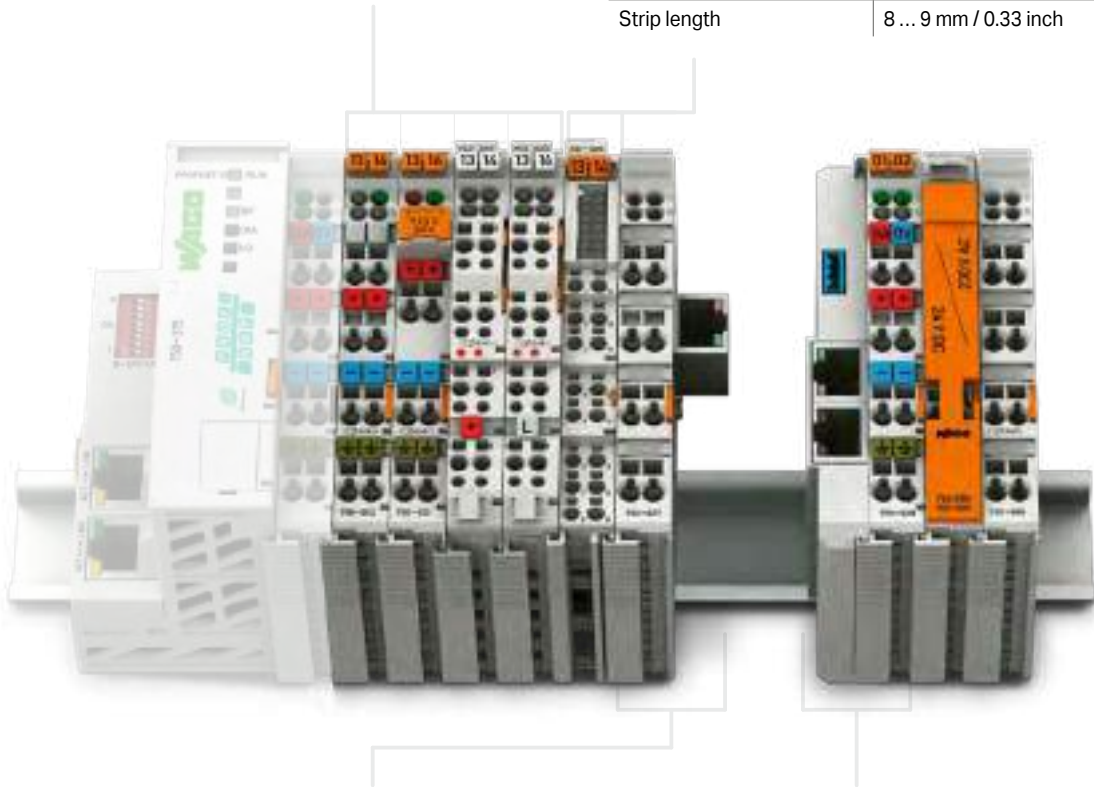

Specialty Housing (End Module for Bus Extension)

Dimensions W x H x D	24 x 100 x 69.8 mm
Depth from upper edge of DIN rail	62.6 mm

Specialty Housing (Coupler Module for Bus Extension)

Dimensions W x H x D	24 x 100 x 69.8 mm
Depth from upper edge of DIN rail	62.6 mm



I/O System –
750 XTR Series

I/O System – 750 and 753 Series, Supply/Segment Modules

Contents

Function	Description	Item Number			Page
		Standard	Extended Temperature	Pluggable	
Power Supply 24 VDC	Power Supply; 24 VDC	750-602*	750-602/025-000	753-602	450
	Power Supply; 24 VDC/5 ... 15 VDC	750-623			451
	Power Supply; 24 VDC; Fuse Holder	750-601*			452
230 VAC/DC 24 VAC 120 VAC 230 VAC	Power Supply; 24 VDC; Fuse Holder; Diagnostics	750-610*			453
	Power Supply; 0 ... 230 VAC/DC	750-612*		753-612	454
	Power Supply; 24 VAC; Fuse Holder	750-617			455
DALI Multi-Master DC/DC Converter 24 VDC with Bus Power Supply	Power Supply; 120 VAC; Fuse Holder	750-615			456
	Power Supply; 230 VAC; Fuse Holder	750-609			457
	Power Supply; 230 VAC; Fuse Holder; Diagnostics	750-611			457
Potential Multiplication Module	DALI Multi-Master DC/DC Converter			753-620	458
	System Power Supply; 24 VDC	750-613*			459
	Potential Multiplication	750-614*		753-614	460
	Potential Multiplication; 8x 24 V	750-603		753-603	461
	Potential Multiplication; 8x 0 V	750-604		753-604	462
	Potential Multiplication; 16x 24 V	750-1605*			463
Filter Module	Potential Multiplication; 16x 0 V	750-1606*			464
	Potential Multiplication; 8x 24 V/8x 0 V	750-1607			465
	Field Supply Filter (Surge); 24 VDC; Higher Isolation	750-624/020-000*			466
	Field Supply Filter (Surge); 24 VDC; Higher Isolation; Without Power Jumper Contacts	750-624/020-001*			467
	Field Supply Filter (Surge); 24 VDC; Higher Isolation; Ground Fault Diagnostics	750-624/020-002			466
	Field Supply Filter (Surge); 24 VDC	750-624			466
	Field Supply Filter (Surge); 24 VDC; without Power Jumper Contacts	750-624/000-001			467
	Supply Filter; 24 VDC; Higher Isolation	750-626/020-000*	750-626/025-001		468
Supply Filter; 24 VDC; Higher Isolation; Ground Fault Diagnostics	750-626/020-002			468	
Local Bus Extension	Filter Module; 24 VDC	750-626	750-626/025-000		468
	Bus Extension End Module	750-627			469
Spacer Module	Coupler Module for Bus Extension	750-628			470
	Binary Spacer Module	750-622			471
	Spacer Module; Active			753-1629	472
	Spacer Module; Active; Without Power Jumper Contacts			753-1629/000-001	472
Distance Module	Spacer Module; Passive			753-629/020-000	473
	Distance Module	750-616*			474
	Distance Module; 24 VDC/230 VAC	750-616/030-000			474
End Module	Distance Module	750-621			475
	End Module	750-600*	750-600/025-000		476
	End Module; with Potential Group	750-600/000-001*			477
Ex i		See Section 7.9			
*This module is also available as a variant of the 750 XTR Series.		See Section 8			

Supply module ▶ 24 VDC



750-602

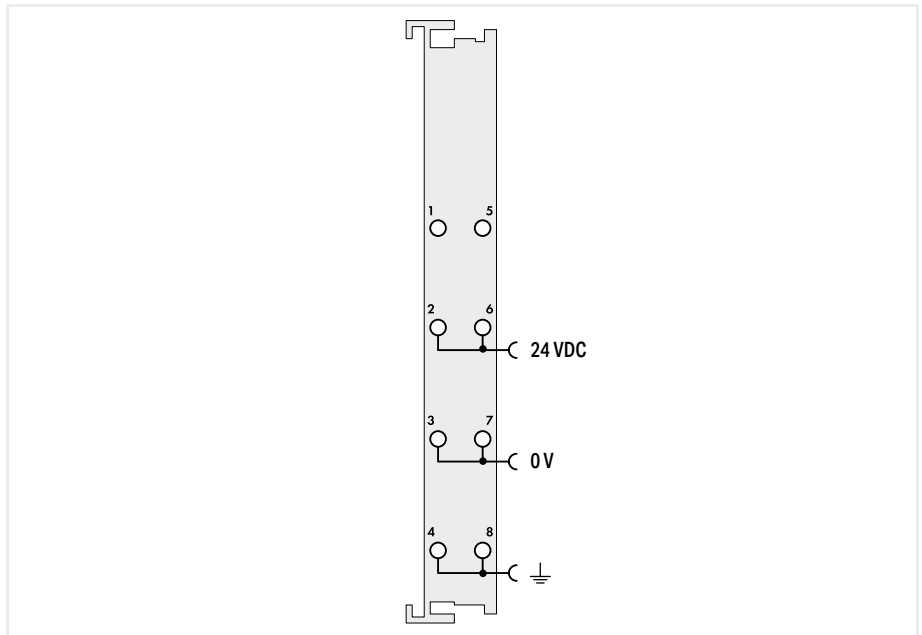

7.10

Item description			
Version			
Item no.			
Order Text			
Technical data			
Pluggable connector	-		pluggable
Supply voltage (system)	5 VDC; via data contacts		
Supply voltage (field)	24 VDC (-25 ... +30 %); via power jumper contacts (power supply via CAGE CLAMP® connection; transmission via spring contact)		
Current carrying capacity (power jumper contacts)	10 A		
Ambient temperature (operation)	0 ... +55 °C	-20 ... +60 °C	0 ... +55 °C
Dimensions W x H x D	(12 x 100 x 69.8) mm		
Approvals	CE; Marine; OrdLoc/HazLoc; ATEX/IECEX		
For data sheet and additional information, see:	wago.com/750-602		wago.com/753-602
Accessories	Item no.	Item no.	Item no.
Plug	-	-	753-110

This I/O module provides the applied supply voltage to the field devices connected to downstream I/O modules.

Supply module ▶ 24 VDC; DIP switch



750-623

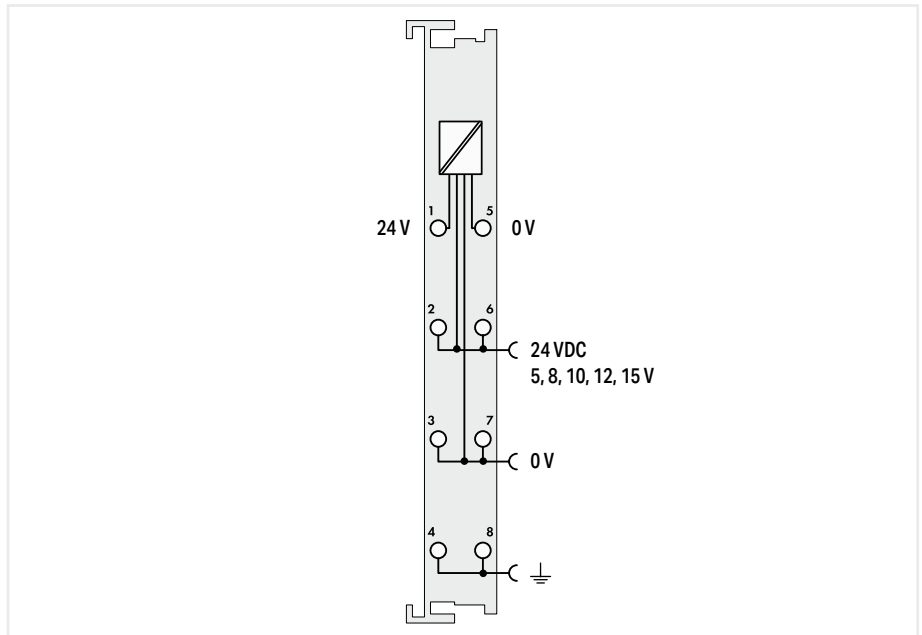

Item description	Power Supply; 24 VDC/5 ... 15 VDC
Version	Standard
Item no.	750-623
Order Text	Power Supply; 24/5-15 VDC
Technical data	
Supply voltage (system)	5 VDC; via data contacts
Supply voltage (field)	24 VDC (-15 ... +20 %); via power jumper contacts (power supply via CAGE CLAMP® connection; transmission via spring contact); Output voltage adjustable in steps via DIP switch: 5 V; 8 V; 10 V; 12 V; 15 V
Total current (system supply)	500 mA
Ambient temperature (operation)	0 ... +55 °C
Dimensions W x H x D	(12 x 100 x 69.8) mm
Approvals	CE; Marine; OrdLoc/HazLoc; ATEX/IECEx
For data sheet and additional information, see:	wago.com/750-623

This I/O module converts the applied supply voltage to a value selected via DIP switch and provides it to the field devices connected to the downstream I/O modules.

Supply module ► 24 VDC; fuse holder



750-601

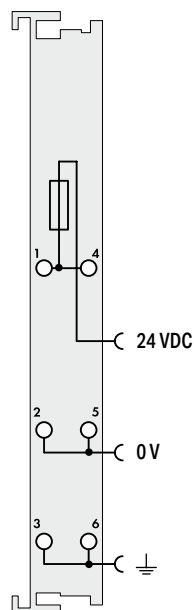

Item description	Power Supply; 24 VDC; Fuse holder
Version	Standard
Item no.	750-601
Order Text	Power Supply; 24 VDC
Technical data	
Supply voltage (system)	5 VDC; via data contacts
Supply voltage (field)	24 VDC (-25 ... +30 %); via power jumper contacts (power supply via CAGE CLAMP® connection; transmission via spring contact)
Current carrying capacity (power jumper contacts)	6.3 A
Fuse	5 x 20; T 6.3 A (not included)
Ambient temperature (operation)	0 ... +55 °C
Dimensions W x H x D	(12 x 100 x 69.8) mm
Approvals	CE; Marine; OrdLoc/HazLoc; ATEX/IECEx
For data sheet and additional information, see:	wago.com/750-601

This I/O module provides the applied supply voltage, protected by a fuse, to the field devices connected to downstream I/O modules. A blown fuse is indicated by an LED.

Supply module ▶ 24 VDC; fuse holder; diagnostics



750-610

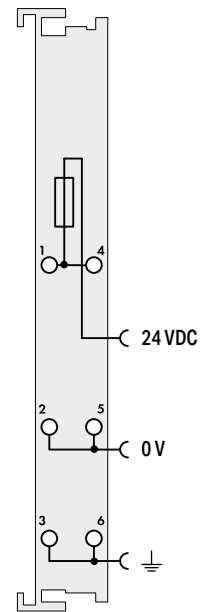

Item description	Power Supply; 24 VDC; Fuse holder; Diagnostics
Version	Diagnostics
Item no.	750-610
Order Text	Power Supply; 24 VDC; Fuse; Diagn
Technical data	
Supply voltage (system)	5 VDC; via data contacts
Supply voltage (field)	24 VDC (-25 ... +30 %); via power jumper contacts (power supply via CAGE CLAMP® connection; transmission via spring contact)
Current consumption (5 V system supply)	5 mA
Current carrying capacity (power jumper contacts)	6.3 A
Fuse	5 x 20; T 6.3 A (not included)
Diagnostics	Supply voltage (field): Detection "on" at > 15 VDC; Detection "off" at < 5 VDC
Data width	2 bits (1 bit current monitoring, 1 bit fuse fault)
Ambient temperature (operation)	0 ... +55 °C
Dimensions W x H x D	(12 x 100 x 69.8) mm
Approvals	CE; Marine; OrdLoc/HazLoc; ATEX/IECEX
For data sheet and additional information, see:	wago.com/750-610

This I/O module provides the applied supply voltage, protected by a fuse, to the field devices connected to downstream I/O modules. A blown fuse is indicated by an LED. The fuse status can also be queried from the fieldbus coupler.

Supply module ▶ 0 ... 230 VAC/DC



750-612

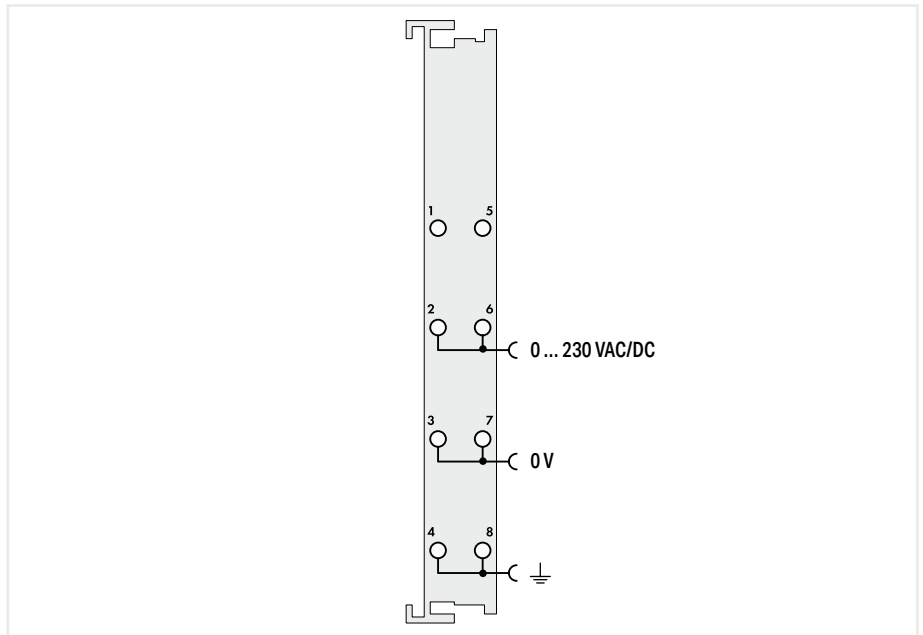

7.10

Item description	Power Supply; 0 ... 230 VAC/DC	
Version	Standard	pluggable (delivery without connector)
Item no.	750-612	753-612
Order Text	Power Supply; 0-230 VAC/VDC	Power Supply; 0-230 VAC/VDC
Technical data		
Pluggable connector	-	pluggable
Supply voltage (system)	5 VDC; via data contacts	
Supply voltage (field)	230 VAC/DC (-15 ... +10 %); via power jumper contacts (power supply via CAGE CLAMP® connection; transmission via spring contact)	
Current carrying capacity (power jumper contacts)	10 A	
Ambient temperature (operation)	0 ... +55 °C	
Dimensions W x H x D	(12 x 100 x 69.8) mm	
Approvals		
For data sheet and additional information, see:	wago.com/750-612	wago.com/753-612
Accessories	Item no.	Item no.
Plug	-	753-110

This I/O module provides the applied supply voltage to the field devices connected to downstream I/O modules.

Supply module ▶ 24 VAC



750-617

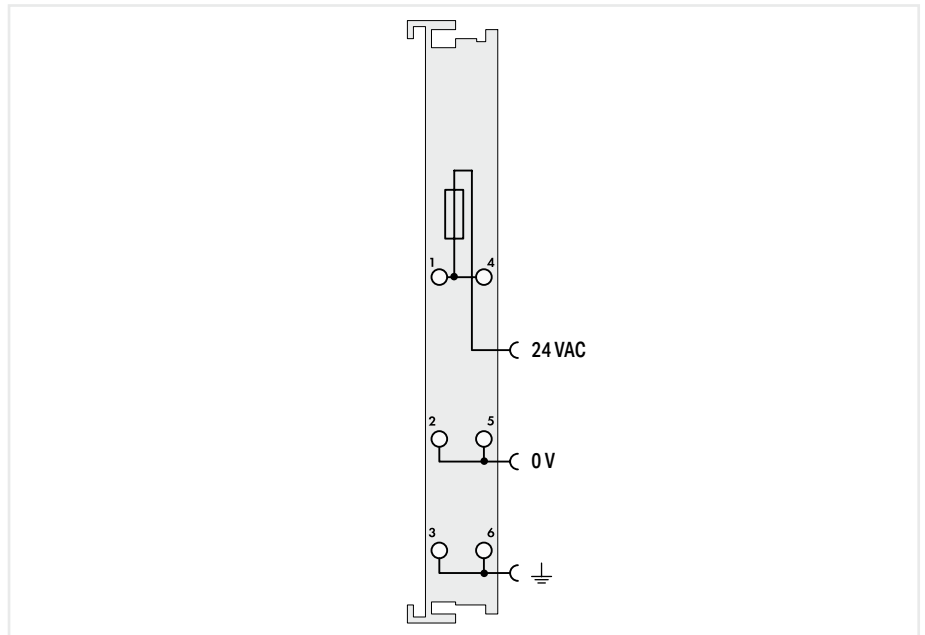

Item description	Power Supply; 24 VAC; Fuse holder
Version	Standard
Item no.	750-617
Order Text	Power Supply; 24 VAC; Fuse
Technical data	
Supply voltage (system)	5 VDC; via data contacts
Supply voltage (field)	24 VAC; via power jumper contacts (power supply via CAGE CLAMP® connection; transmission via spring contact)
Current carrying capacity (power jumper contacts)	6.3 A
Fuse	5 x 20; T 6.3 A (not included)
Ambient temperature (operation)	0 ... +55 °C
Dimensions W x H x D	(12 x 100 x 69.8) mm
Approvals	CE, UL, OrdLoc
For data sheet and additional information, see:	wago.com/750-617

This I/O module provides the applied supply voltage, protected by a fuse, to the field devices connected to downstream I/O modules. A blown fuse is indicated by an LED.

Supply module ▶ 120 VAC



750-615

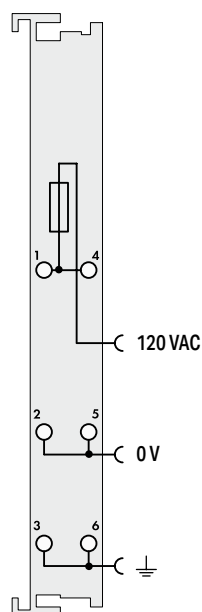

Item description

Version

Item no.

Order Text

Power Supply; 120 VAC; Fuse holder

Standard

750-615

Power Supply; 120 VAC; Fuse

Technical data

Supply voltage (system)

5 VDC; via data contacts

Supply voltage (field)

120 VAC; via power jumper contacts (power supply via CAGE CLAMP® connection; transmission via spring contact)

Current carrying capacity (power jumper contacts)

6.3 A

Fuse

5 x 20; T 6.3 A (not included)

Ambient temperature (operation)

0 ... +55 °C

Dimensions W x H x D

(12 x 100 x 69.8) mm

Approvals

CE; OrdLoc/HazLoc; ATEX/IECEx

For data sheet and additional information, see:

wago.com/750-615

This I/O module provides the applied supply voltage, protected by a fuse, to the field devices connected to downstream I/O modules. A blown fuse is indicated by an LED.

Supply module ▶ 230 VAC



750-609

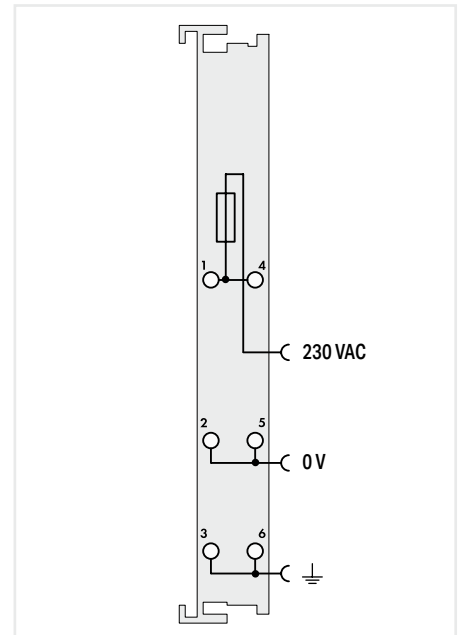
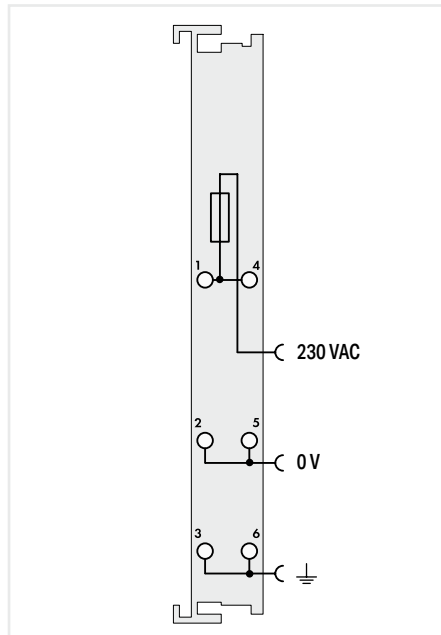

Item description
Version
Item no.
Order Text

Power Supply; 230 VAC; Fuse holder
Standard
750-609
Power Supply; 230 VAC; Fuse

Power Supply; 230 VAC; Fuse holder; Diagnostics
Diagnostics
750-611
Power Supply; 230 VAC; Fuse; Diagn

Technical data
Supply voltage (system)
Supply voltage (field)
Current consumption (5 V system supply)
Current carrying capacity (power jumper contacts)
Fuse
Diagnostics
Data width
Ambient temperature (operation)
Dimensions W x H x D
Approvals

5 VDC; via data contacts
230 VAC (-15 ... +10 %); via power jumper contacts (power supply via CAGE CLAMP® connection; transmission via spring contact)
-
6.3 A
5 x 20; T 6.3 A (not included)
-
-
0 ... +55 °C
(12 x 100 x 69.8) mm
CE; Marine; OrdLoc/HazLoc; ATEX/IECEX

5 VDC; via data contacts
230 VAC (-15 ... +10 %); via power jumper contacts (power supply via CAGE CLAMP® connection; transmission via spring contact)
5 mA
6.3 A
5 x 20; T 6.3 A (not included)
Supply voltage (field): Detection "on" at > 164 VAC; Detection "off" at < 40 VAC
2 bits (1 bit current monitoring, 1 bit fuse fault)
0 ... +55 °C
(12 x 100 x 69.8) mm
CE; Marine; OrdLoc/HazLoc; ATEX/IECEX

For data sheet and additional information, see:

wago.com/750-609
This I/O module provides the applied supply voltage, protected by a fuse, to the field devices connected to downstream I/O modules. A blown fuse is indicated by an LED.

wago.com/750-611
This I/O module provides the applied supply voltage, protected by a fuse, to the field devices connected to downstream I/O modules. A blown fuse is indicated by an LED. The fuse status can also be queried from the fieldbus coupler.

Supply module ► DALI



753-620

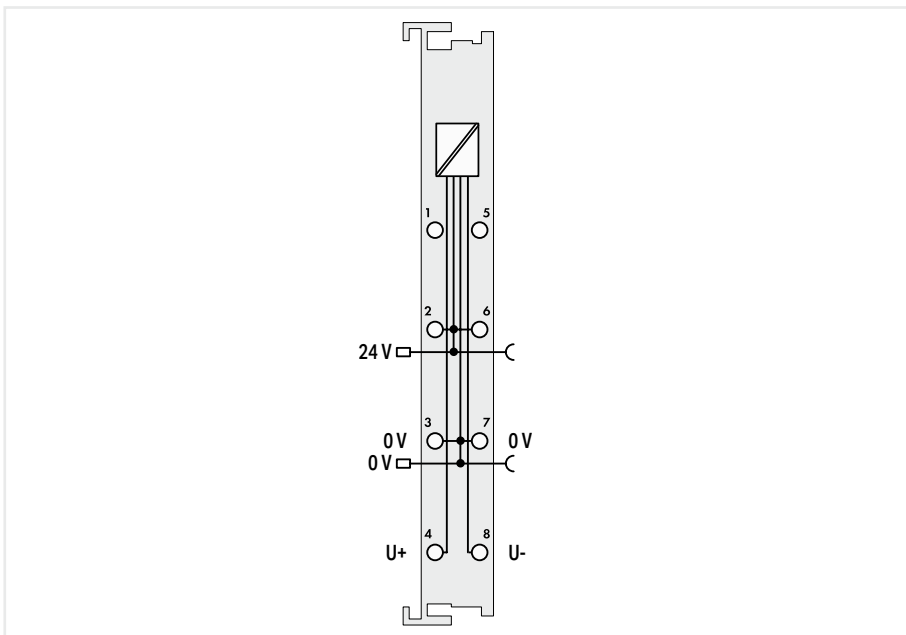

7.10

Item description	DALI Multi-Master DC/DC Converter
Version	pluggable
Item no.	753-620
Order Text	DALI Multi-Master DC/DC-Converter
Technical data	
Pluggable connector	pluggable
Supply voltage (system)	5 VDC; via data contacts
Supply voltage (field)	24 VDC (-25 ... +30 %); via power jumper contacts (power supply via blade contact; transmission via spring contact); Supply voltage (DALI): 18 VDC; at +U and -U via CAGE CLAMP® connection
Total current (system supply)	200 mA
Current carrying capacity (power jumper contacts)	10 A
Test voltage (input/output)	1.5 kV
Ambient temperature (operation)	0 ... +55 °C
Dimensions W x H x D	(12 x 100 x 69.8) mm
Approvals	CE; Marine; OrdLoc
For data sheet and additional information, see:	wago.com/753-620

This I/O module powers the DALI Multi-Master (753-647). It uses the field supply, which is connected via the power jumper contacts. Cable bridges connect the module to the DALI Multi-Master.

System power supply ► 24 VDC; system power supply



750-613

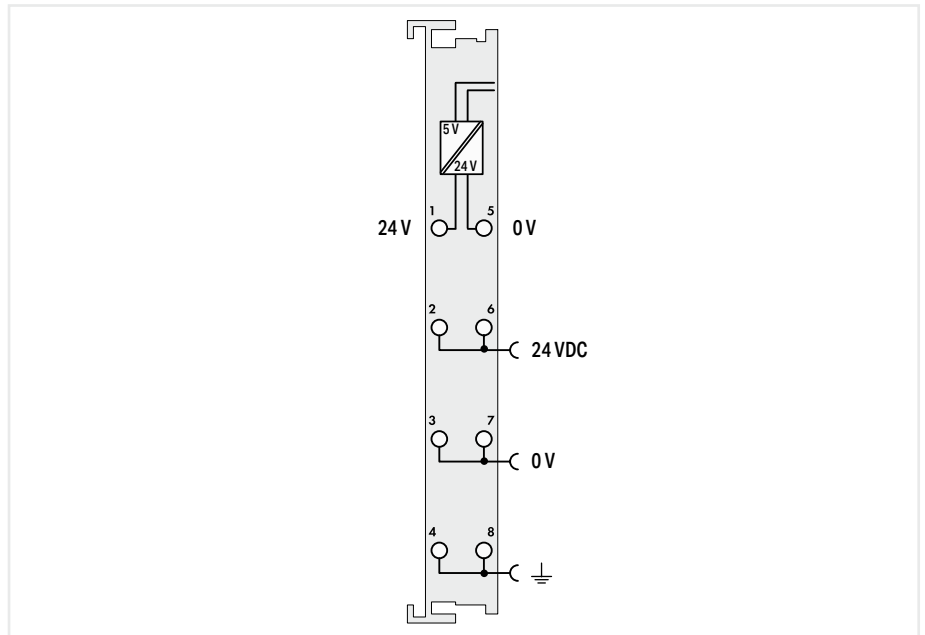

Item description	System Power Supply; 24 VDC
Version	Standard
Item no.	750-613
Order Text	System Power Supply; 24 VDC
Technical data	
Supply voltage (system)	24 VDC (-25 ... +30 %); via pluggable connector (CAGE CLAMP® connection)
Input current (typ.) at nominal load (24 V)	500 mA
Power supply efficiency (typ.) at nominal load (24 V)	90 %
Supply voltage (field)	24 VDC (-25 ... +30 %); via power jumper contacts (power supply via CAGE CLAMP® connection; transmission via spring contact)
Total current (system supply)	2000 mA
Current carrying capacity (power jumper contacts)	10 A
Isolation	500 V system/field
Ambient temperature (operation)	0 ... +55 °C
Dimensions W x H x D	(12 x 100 x 69.8) mm
Approvals	CE; Marine; OrdLoc/HazLoc; ATEX/IECEX
For data sheet and additional information, see:	wago.com/750-613

This I/O module provides the applied supply voltage to the field devices connected to downstream I/O modules. It also serves as an additional system supply for large nodes, covering the I/O modules' power demands.

Potential distribution module ▶ 0 ... 230 VAC/DC



750-614

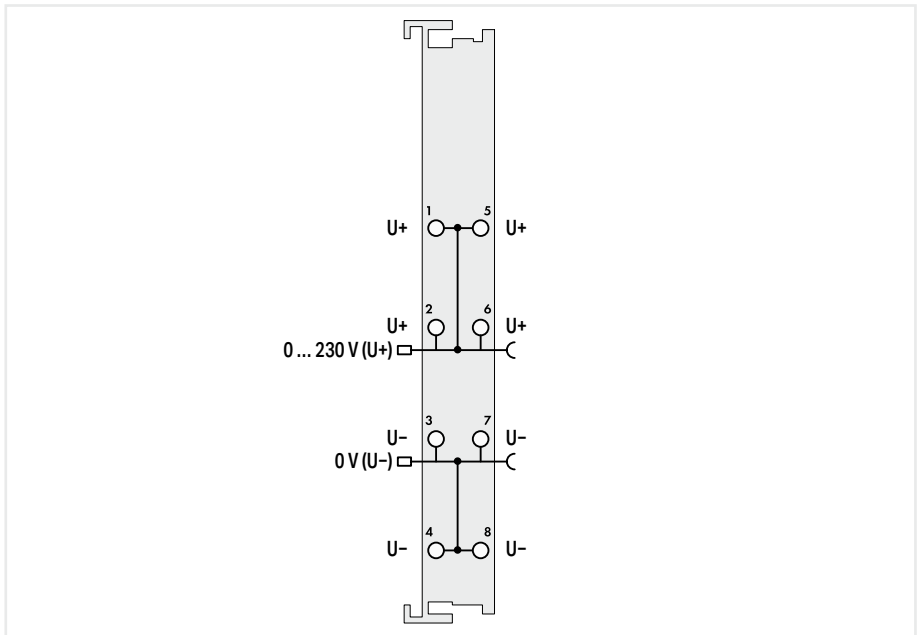

7.10

Item description	Potential Distribution
Version	
Item no.	750-614
Order Text	Potential Distribution

Standard	pluggable (delivery without connector)
Item no.	753-614
Potential Distribution	Potential Distribution

Technical data	
Pluggable connector	-
Supply voltage (system)	5 VDC; via data contacts
Supply voltage (field)	230 VAC/DC; via power jumper contacts (power supply via blade contact; transmission via spring contact)
Current carrying capacity (power jumper contacts)	10 A
Ambient temperature (operation)	0 ... +55 °C
Dimensions W x H x D	(12 x 100 x 69.8) mm
Approvals	CE; Marine; OrdLoc/HazLoc; ATEX/IECEX
For data sheet and additional information, see:	wago.com/750-614

	pluggable
	230 VAC/DC; via power jumper contacts (power supply via blade contact; transmission via spring contact)
	10 A
	0 ... +55 °C
	(12 x 100 x 69.8) mm
	CE; Marine; OrdLoc/HazLoc; ATEX/IECEX
	wago.com/753-614

Accessories	
Plug	

Item no.	Item no.
-	753-110

Potential distribution module ▶ 8x 24 V



750-603

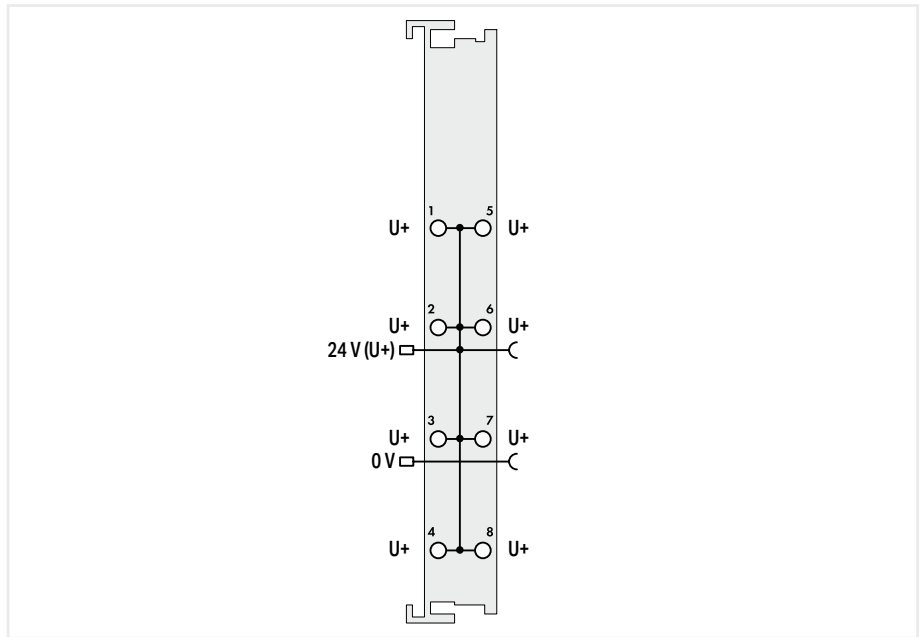

Item description	Potential Distribution; 8x 24 V	
Version	Standard	pluggable (delivery without connector)
Item no.	750-603	753-603
Order Text	Potential Distribution; 8*24V	Potential Distribution; 8*24V
Technical data		
Pluggable connector	-	pluggable
Supply voltage (system)	5 VDC; via data contacts	
Supply voltage (field)	24 VDC (-25 ... +30 %); via power jumper contacts (power supply via blade contact; transmission via spring contact)	
Current carrying capacity (power jumper contacts)	10 A	
Ambient temperature (operation)	0 ... +55 °C	
Dimensions W x H x D	(12 x 100 x 69.8) mm	
Approvals	CE; L; Marine; OrdLoc/HazLoc; ATEX/IECEX	
For data sheet and additional information, see:	wago.com/750-603	wago.com/753-603
Accessories	Item no.	Item no.
Plug	-	753-110

7.10
Supply and Segment Modules

Potential distribution module ▶ 8x 0 V



750-604

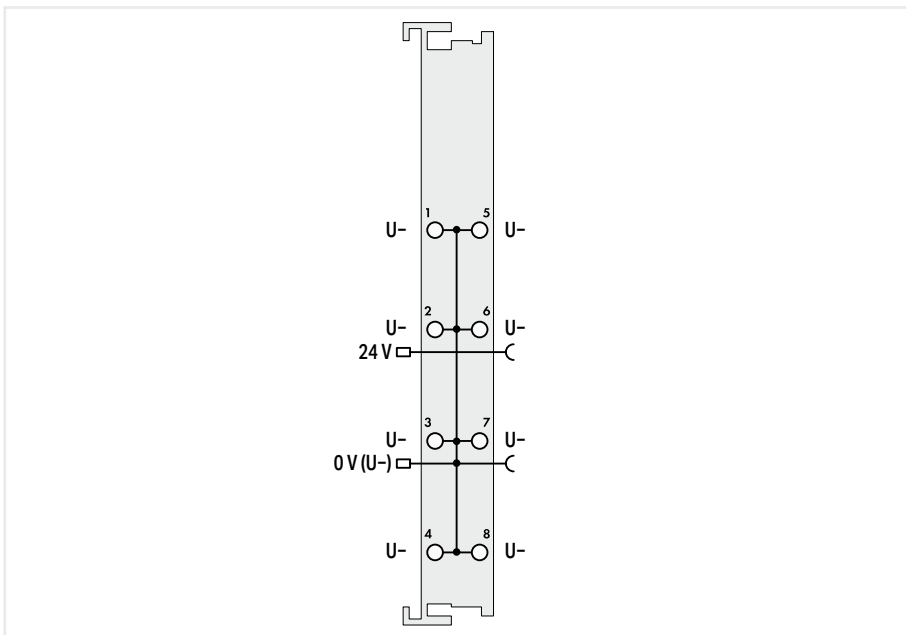

7.10

Item description	Potential Distribution; 8x 0 V
Version	Standard
Item no.	750-604
Order Text	Potential Distribution; 8*0V

Standard	pluggable (delivery without connector)
Item no.	753-604
Order Text	Potential Distribution; 8*0V

Technical data	
Pluggable connector	-
Supply voltage (system)	5 VDC; via data contacts
Supply voltage (field)	24 VDC (-25 ... +30 %); via power jumper contacts (power supply via blade contact; transmission via spring contact)
Current carrying capacity (power jumper contacts)	10 A
Ambient temperature (operation)	0 ... +55 °C
Dimensions W x H x D	(12 x 100 x 69.8) mm
Approvals	CE; Marine; OrdLoc/HazLoc; ATEX/IECEX
For data sheet and additional information, see:	wago.com/750-604

Approvals	pluggable
For data sheet and additional information, see:	wago.com/753-604

Accessories	
Plug	

Item no.	Item no.
-	753-110

Potential distribution module ▶ 16x 24 V



750-1605

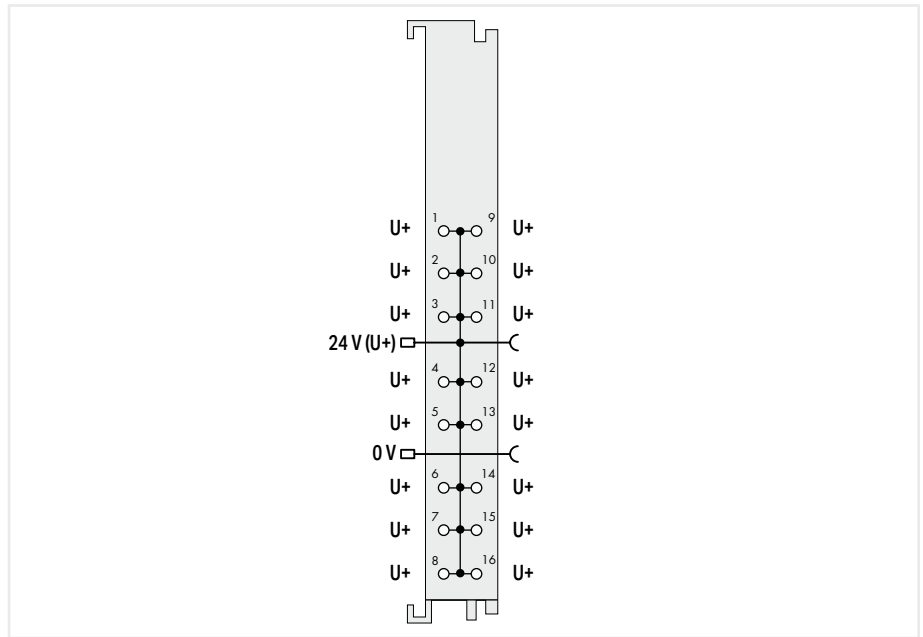

Item description
Version
Item no.
Order Text

Potential Distribution; 16x 24 V
Standard with 16 connectors
750-1605
Potential Distribution; 16*24V

Technical data
Supply voltage (system)
Supply voltage (field)
Current carrying capacity (power jumper contacts)
Ambient temperature (operation)
Dimensions W x H x D
Approvals

5 VDC; via data contacts
24 VDC (-25 ... +30 %); via power jumper contacts (power supply via blade contact; transmission via spring contact)
10 A
0 ... +55 °C
(12 x 100 x 69) mm
CE; Marine; OrdLoc/HazLoc; ATEX/IECEX

For data sheet and additional information, see:

wago.com/750-1605

Potential distribution module ▶ 16x 0 V



750-1606

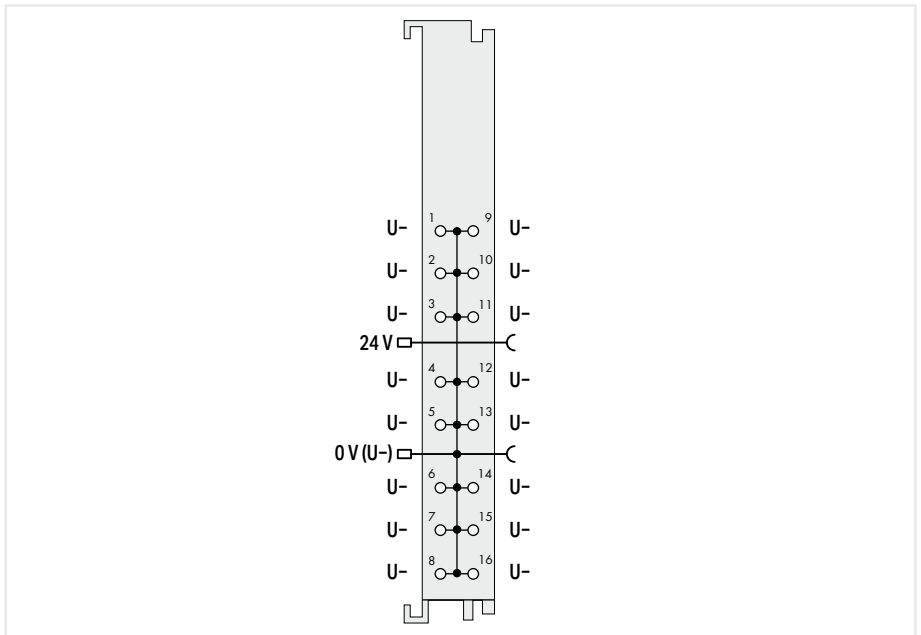

7.10

Item description	Potential Distribution; 16x 0 V
Version	Standard with 16 connectors
Item no.	750-1606
Order Text	Potential Distribution; 16*0V
Technical data	
Supply voltage (system)	5 VDC; via data contacts
Supply voltage (field)	24 VDC (-25 ... +30 %); via power jumper contacts (power supply via blade contact; transmission via spring contact)
Current carrying capacity (power jumper contacts)	10 A
Ambient temperature (operation)	0 ... +55 °C
Dimensions W x H x D	(12 x 100 x 69) mm
Approvals	CE; Marine; OrdLoc/HazLoc; ATEX/IECEX
For data sheet and additional information, see:	wago.com/750-1606

Potential distribution module ▶ 8x 24 V/8x 0 V



750-1607

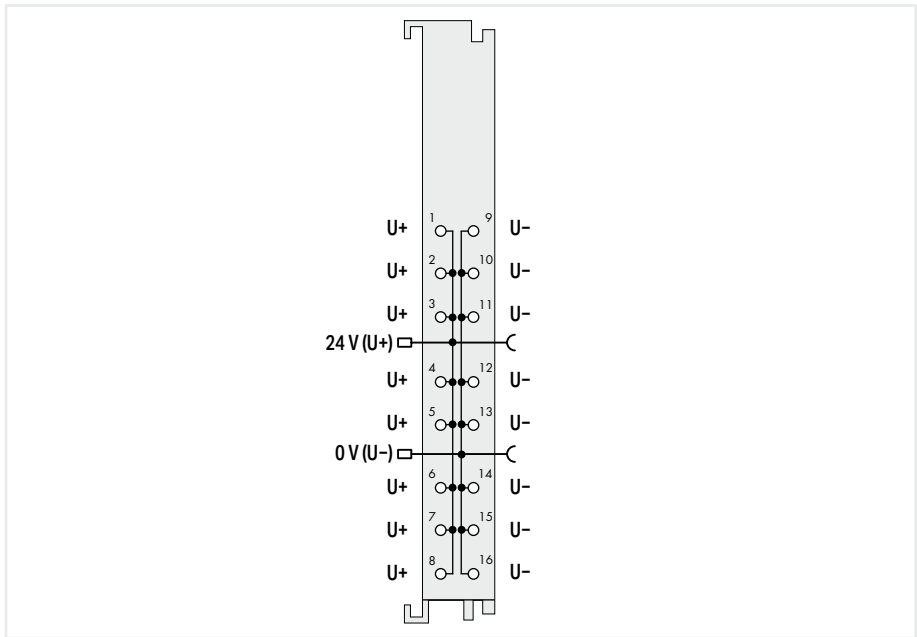

Item description
Version
Item no.
Order Text

Potential Distribution; 8x 24 V/8x 0 V
Standard with 16 connectors
750-1607
Potential Distribution; 8*24V/8*0V

Technical data
Supply voltage (system)
Supply voltage (field)
Current carrying capacity (power jumper contacts)
Ambient temperature (operation)
Dimensions W x H x D
Approvals

5 VDC; via data contacts
24 VDC (-25 ... +30 %); via power jumper contacts (power supply via blade contact; transmission via spring contact)
10 A
0 ... +55 °C
(12 x 100 x 69) mm
CE; Marine; OrdLoc/HazLoc; ATEX/IECEX

For data sheet and additional information, see:

wago.com/750-1607

Filter module ► Field supply filter



750-624

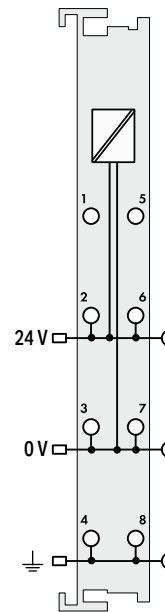

Item description	Field Supply Filter (Surge); 24 VDC		
Version	Standard	Higher isolation	higher isolation; ground fault diagnostics
Item no.	750-624	750-624/020-000	750-624/020-002
Order Text	Field Supply Filter; 24 VDC	Field Supply Filter; 24 VDC; HI	Field Supply Filter; 24 VDC HI; GF
Technical data			
Supply voltage (system)	5 VDC; via data contacts		
Supply voltage (field)	24 VDC (-25 ... +30 %); via power jumper contacts (power supply via blade contact; transmission via spring contact)	24 VSELV DC (-25 ... +30 %); via power jumper contacts (power supply via blade contact; transmission via spring contact)	
Current consumption (5 V system supply)	-		29 mA
Current carrying capacity (power jumper contacts)	10 A		
Current consumption, field supply (module with no external load)	-		16 mA
Application	Marine-certified operation in conjunction with the Ex i supply module and the use of 750 Series PROFIsafe Modules	Marine-certified operation in conjunction with 750 Series I/O Modules	
Data width	-		8-bit input; 8-bit output
Ambient temperature (operation)	0 ... +55 °C		
Dimensions W x H x D	(12 x 100 x 69.8) mm		
Approvals	CE; Marine; OrdLoc/HazLoc; ATEX/IECEx	CE; Marine; OrdLoc/HazLoc	CE; Marine; OrdLoc/HazLoc

For data sheet and additional information, see:

wago.com/750-624

Use in systems with isolation monitoring requires the high isolation variants.

Ground diagnostics (response values) 750-624/020-002:

- Pre-alarm 50 kΩ (±15 %)
- Main alarm 25 kΩ (±15 %)
- Hysteresis (typ.) 25 ... 30 %
- Response time ≤ 5 s (typ. 2.5 s)
- Internal resistance DC (test circuit) > 10 MΩ (test inactive), > 90 kΩ (test active)
- Test current ≤ 180 μA (RF=0 Ω)
- Permissible system leakage capacitance ≤ 2 μF

Filter module ▶ Field supply filter; without power jumper contacts



750-624/000-001

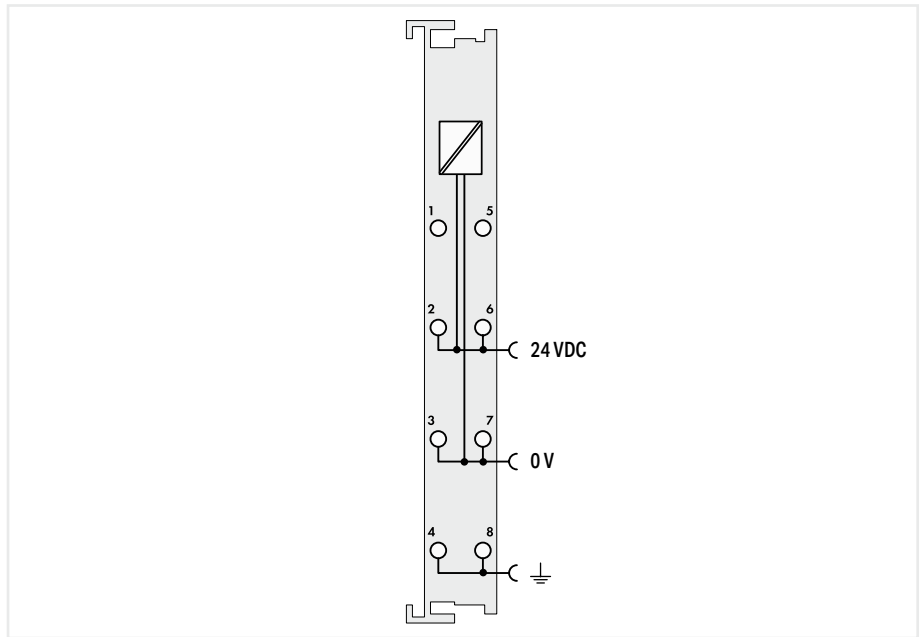

Item description	Field Supply Filter (Surge); 24 VDC	
Version	without power jumper contacts	higher isolation; without power jumper contacts
Item no.	750-624/000-001	750-624/020-001
Order Text	Field Supply Filter; 24 VDC; NC	Field Supply Filter; 24 VDC; HI; NC

Technical data		
Supply voltage (system)	5 VDC; via data contacts	
Supply voltage (field)	24 VDC (-25 ... +30 %); via pluggable connector (CAGE CLAMP® connection)	
Application	Marine-certified operation in conjunction with the Ex i supply module and the use of 750 Series PROFIsafe Modules	Marine-certified operation in conjunction with 750 Series I/O Modules
Ambient temperature (operation)	0 ... +55 °C	
Dimensions W x H x D	(12 x 100 x 69.8) mm	
Approvals	CE, Marine, OrdLoc/HazLoc	CE, Marine, OrdLoc/HazLoc; ATEX/IECEx
For data sheet and additional information, see:	wago.com/750-624/000-001	

Use in systems with isolation monitoring requires the high isolation variants.

Filter module ► Power supply filter



750-626

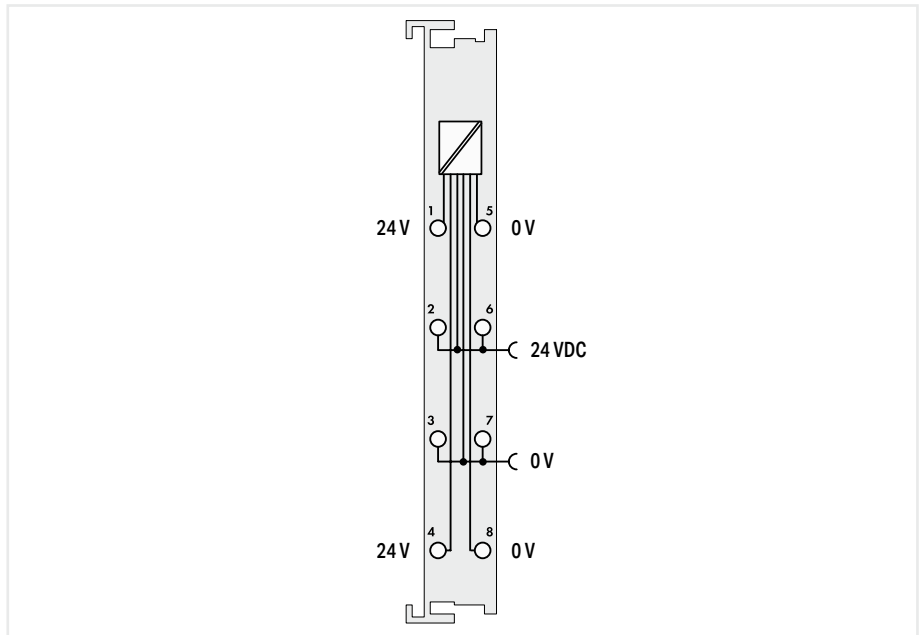

7.10

Item description	Supply Filter; 24 VDC				
Version	Standard	ext. temperature	Higher isolation	higher isolation; ground fault diagnostics	Higher isolation; extended temperature
Item no.	750-626	750-626/025-000	750-626/020-000	750-626/020-002	750-626/025-001
Order Text	Supply Filter; 24 VDC	Supply Filter; 24 VDC; T	Supply Filter; 24 VDC; HI	Supply Filter; 24 VDC HI; GF	Supply Filter; 24 VDC; HI; T
Technical data					
Supply voltage (system)	24 VDC (-25 ... +30 %); via pluggable connector (CAGE CLAMP® connection)			24 VDC (-25 ... +30 %)	24 VDC (-25 ... +30 %); via pluggable connector (CAGE CLAMP® connection)
Supply voltage (field)	24 VDC (-25 ... +30 %); via power jumper contacts (power supply via CAGE CLAMP® connection; transmission via spring contact)			24 VSELV DC (-25 ... +30 %); via power jumper contacts (power supply via CAGE CLAMP® connection; transmission via spring contact)	24 VDC (-25 ... +30 %); via power jumper contacts (power supply via CAGE CLAMP® connection; transmission via spring contact)
Current consumption (5 V system supply)	-			29 mA	-
Current via system voltage (max.)	1.5 A (1 A up to hardware version 04)	1.5 A (1 A up to hardware version 04)	1.5 A (1 A up to hardware version 04)	-	1.5 A (1 A up to hardware version 04)
Current carrying capacity (power jumper contacts)	10 A				
Current consumption, field supply (module with no external load)	-			16 mA	-
Isolation	-			300 VDC (limited by a transient protection device) system/field	-
Application	Marine-certified operation in conjunction with the Ex i supply module and the use of 750 Series PROFIsafe Modules		Marine-certified operation in conjunction with 750 Series Couplers and Controllers		
Data width	-			8-bit input; 8-bit output	-
Ambient temperature (operation)	0 ... +55 °C	-20 ... +60 °C	0 ... +55 °C		-20 ... +60 °C
Dimensions W x H x D	(12 x 100 x 69.8) mm				
Approvals	CE; Marine; OrdLoc/HazLoc; ATEX/IECEX			CE; Marine; OrdLoc/HazLoc	CE; Marine; OrdLoc/HazLoc; ATEX/IECEX

For data sheet and additional information, see:

wago.com/750-626

Use in systems with isolation monitoring requires the high isolation variants.

Ground diagnostics (response values) 750-626/020-002:

- Pre-alarm 50 kΩ (±15 %)
- Main alarm 25 kΩ (±15 %)
- Hysteresis (typ.) 25 ... 30 %
- Response time ≤ 5 s (typ. 2.5 s)
- Internal resistance DC (test circuit) >10 MΩ (test inactive), >90 kΩ (test active)
- Test current ≤180 μA (RF=0 Ω)
- Permissible system leakage capacitance ≤ 2 μF

Bus extension ► End module



750-627

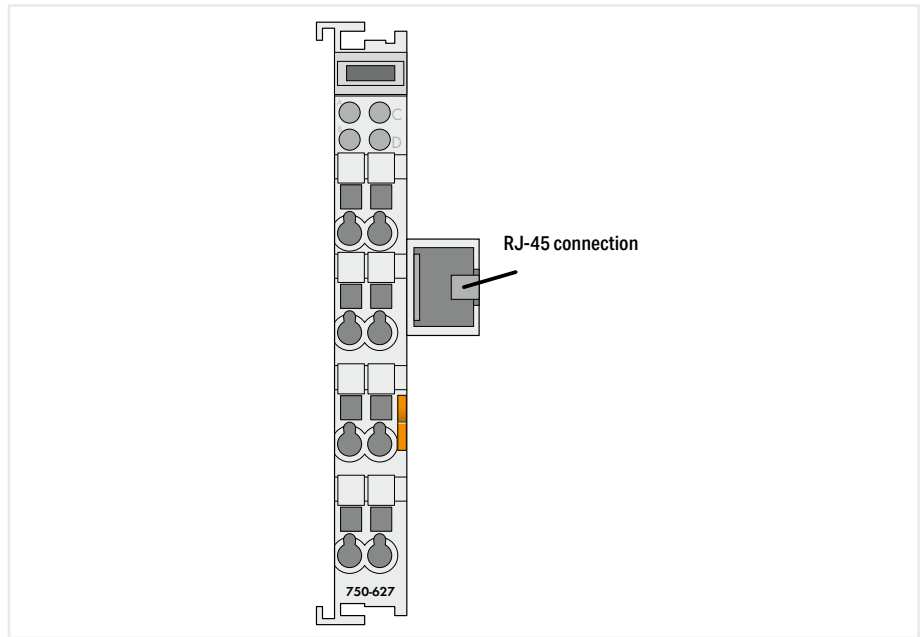

RJ-45 connection

Item description
Version
Item no.
Order Text

Bus Extension End Module
Standard
750-627
Bus Extension End Module

Technical data
Device-specific
Connection technology: communication/fieldbus
Supply voltage (system)
Current consumption (5 V system supply)
Isolation
Ambient temperature (operation)
Dimensions W x H x D
Approvals

Number of coupler modules: up to 10; Distance (max.): 5 m (10 m see manual); (end/coupler modules or coupler/coupler modules)
Local bus: 1 x RJ-45
5 VDC; via data contacts
70 mA
500 V system/field
0 ... +55 °C
(24 x 100 x 69.8) mm
CE; Marine; OrdLoc

For data sheet and additional information, see:

wago.com/750-627

Bus extension ► Coupler module



750-628

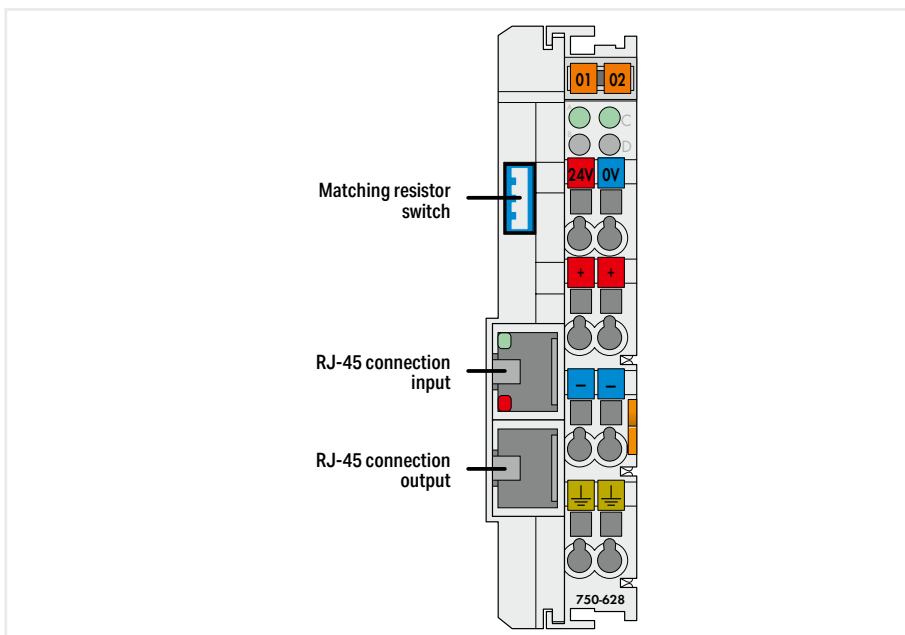

Item description

Version

Item no.

Order Text

Bus Extension Coupler Module

Standard

750-628

Bus Extension Coupler Module

Technical data

Number of modules per node (max.)

64

Device-specific

Distance (max.): 5 m (10 m see manual); (end/coupler modules or coupler/coupler modules)

Connection technology: communication/fieldbus

Local bus: 2 x RJ-45

Supply voltage (system)

24 VDC (-15 ... +20 %); via pluggable connector (CAGE CLAMP® connection)

Input current (typ.) at nominal load (24 V)

200 mA

Power supply efficiency (typ.) at nominal load (24 V)

76 %

Supply voltage (field)

24 VDC (-15 ... +20 %); via power jumper contacts (power supply via CAGE CLAMP® connection; transmission via spring contact)

Current consumption (5 V system supply)

150 mA

Total current (system supply)

400 mA

Current carrying capacity (power jumper contacts)

10 A

Isolation

500 V system/field

Ambient temperature (operation)

0 ... +55 °C

Dimensions W x H x D

(24 x 100 x 69.8) mm

Approvals

CE; Marine; OrdLoc

For data sheet and additional information, see:

wago.com/750-628

Spacer module ► Binary



750-622

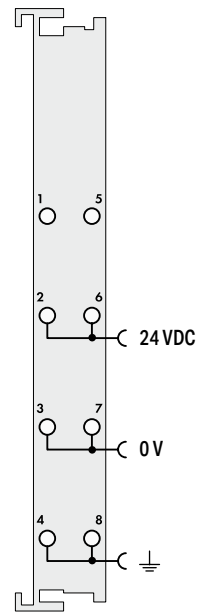

Item description
Version
Item no.
Order Text

Binary Spacer Module
Standard
750-622
Binary Spacer Module

Technical data
Supply voltage (system)
Supply voltage (field)
Current consumption (5 V system supply)
Current carrying capacity (power jumper contacts)
Isolation
Data width
Operating mode
Ambient temperature (operation)
Dimensions W x H x D
Approvals

5 VDC; via data contacts
24 VDC (-15 ... +20 %); via power jumper contacts (power supply via CAGE CLAMP® connection; transmission via spring contact)
10 mA
10 A
500 V system/field
2, 4, 6 or 8 bits (adjustable via DIP switches)
Inputs DIP 3: OFF; Outputs DIP 3: ON
0 ... +55 °C
(12 x 100 x 69.8) mm
CE, RoHS, OrdLoc/HazLoc, ATEX/IECEx

For data sheet and additional information, see:

wago.com/750-622

This binary spacer module reserves bit addresses in the process image of a fieldbus node.

Spacer module ► active



753-1629

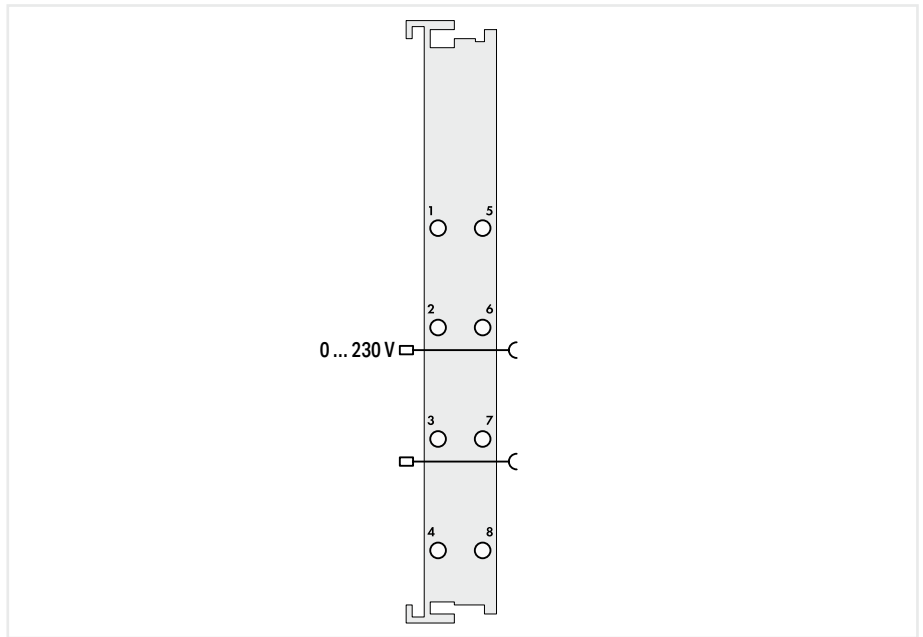

7.10

Item description
Version
Item no.
Order Text

Spacer Module	
active; pluggable (delivery without connector)	active; without power jumper contacts; pluggable (delivery without connector)
753-1629	753-1629/000-001
Spacer Module; Active	Spacer Module; Active; NC

Technical data	
Pluggable connector	pluggable
Supply voltage (system)	5 VDC; via data contacts
Supply voltage (field)	Field-side supply via power jumper contacts
Ambient temperature (operation)	0 ... +55 °C
Dimensions W x H x D	(12 x 100 x 69.8) mm
Approvals	CE, UL, OrdLoc
For data sheet and additional information, see: wago.com/753-1629	

Item no.	
753-110	753-110

Accessories	
Plug	

This active spacer module enables both hardware and software space reservation for standard function modules (digital input/output modules and analog input/output modules) in PROFIBUS/PROFINET networks (only in conjunction with 750-333, 750-375, 750-377).

Spacer module ► passive

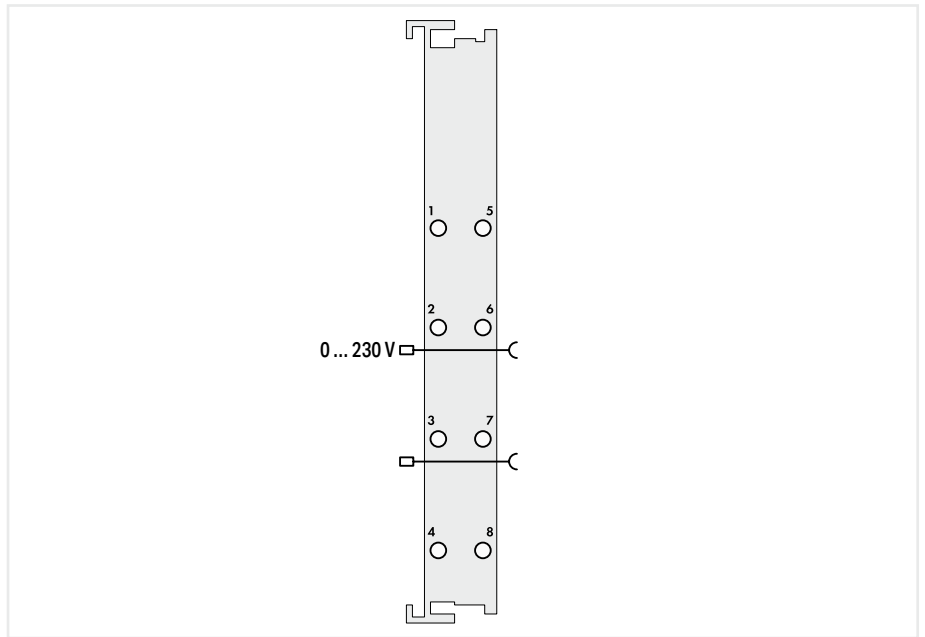

Item description	Spacer Module
Version	passive; pluggable (delivery without connector)
Item no.	753-629/020-000
Order Text	Spacer Module; Passive
Technical data	
Pluggable connector	pluggable
Supply voltage (system)	5 VDC; via data contacts
Supply voltage (field)	Field-side supply via power jumper contacts
Ambient temperature (operation)	0 ... +55 °C
Dimensions W x H x D	(12 x 100 x 69.8) mm
Approvals	CE, UL, OrdLoc
For data sheet and additional information, see:	wago.com/753-629/020-000
Accessories	Item no.
Plug	753-110

This passive spacer module enables hardware space reservation for standard function modules (digital input/output modules and analog input/output modules).

Distance module ▶ Distance module

7.10



750-616

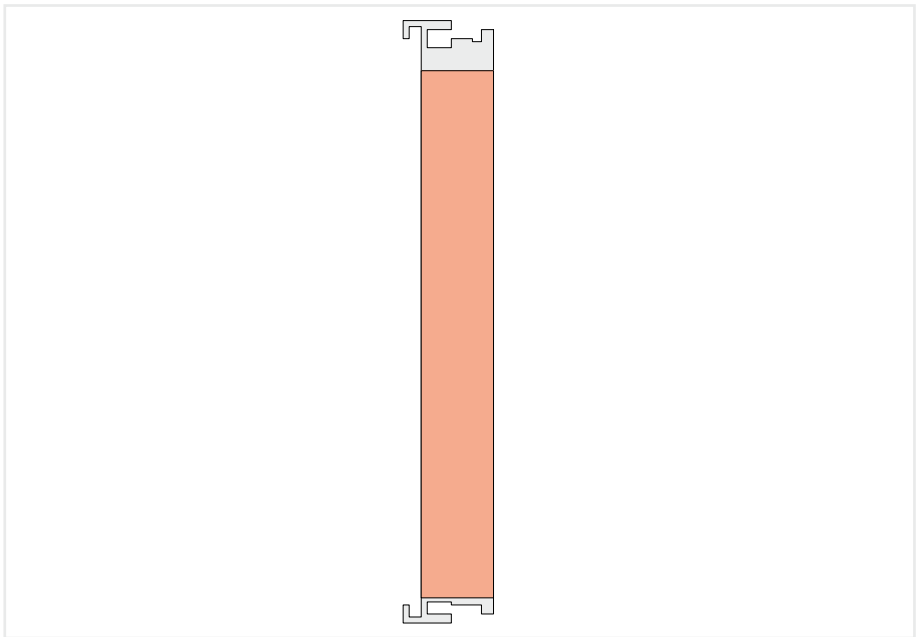

Item description
Version
Item no.
Order Text

Distance Module	
Standard	labeled
750-616	750-616/030-000
Distance Module	Distance Module; 24 VDC/230 VAC

Technical data
Supply voltage (system)
Ambient temperature (operation)
Dimensions W x H x D
Approvals

5 VDC; via data contacts
0 ... +55 °C
(12 x 100 x 69.8) mm
CE; Marine; OrdLoc/HazLoc; ATEX/IECEx wago.com/750-616

For data sheet and additional information, see:

This distance module visually divides a fieldbus node into sections. The 750-616 Distance Module has no power jumper contacts. The labeled version of the distance module is available under the item number 750-616/030-000.

Notice:

Operation of the adjacent I/O modules requires a supply module.

Distance module ► Distance module; with power jumper contacts



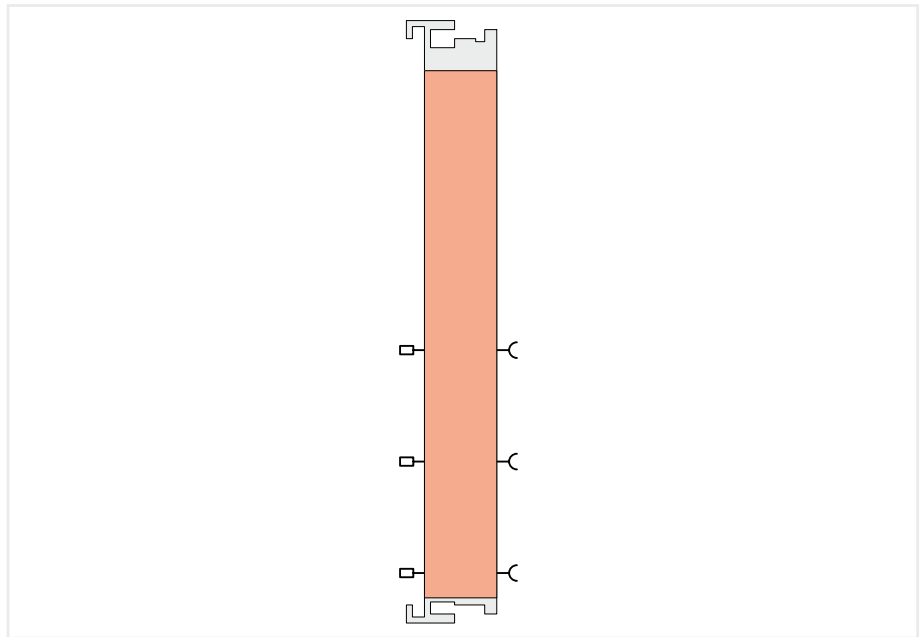

750-621



Item description
Version
Item no.
Order Text

Distance Module
with power jumper contacts
750-621
Distance Module

Technical data
Supply voltage (system)
Ambient temperature (operation)
Dimensions W x H x D
Approvals

5 VDC; via data contacts
0 ... +55 °C
(12 x 100 x 69.8) mm
CE,  OrdLoc/HazLoc,  ATEX/IECEX
wago.com/750-621

For data sheet and additional information, see:

The 750-621 Distance Module has power jumper contacts that can supply the power to adjacent I/O modules.

Bus end module

7.10



750-600

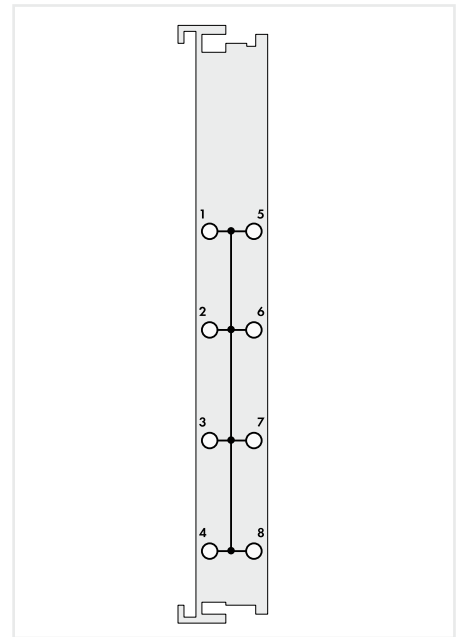
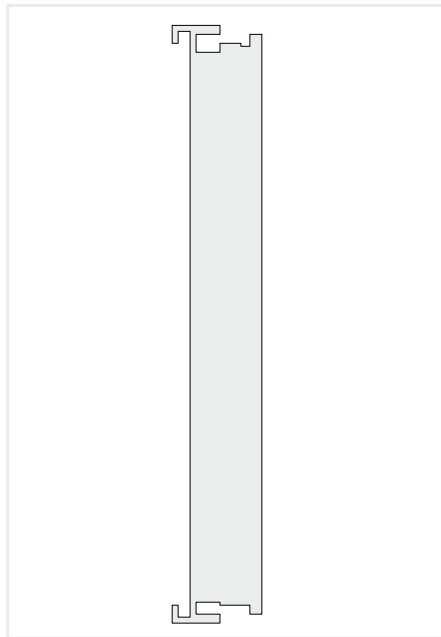

Item description
Version
Item no.
Order Text

End Module	
Standard	ext. temperature
750-600	750-600/025-000
End module	End Module; T

End Module; with Potential Group	
Standard	
750-600/000-001	
End Module; with Potential Group	

Technical data	
Supply voltage (system)	-
Voltage (potential group)	-
Rated surge voltage	-

5 VDC; via data contacts	
0 ... 230 VAC/DC; Supply via CAGE CLAMP® contacts	
5 kV per EN 60870-2-1 / Class VV3, or 6.4 kV per EN 61010-1	

Ambient temperature (operation)	0 ... +55 °C	-20 ... +60 °C
Dimensions W x H x D	(12 x 100 x 69.8) mm	

0 ... +55 °C	
(12 x 100 x 67.8) mm	

Approvals
For data sheet and additional information, see:

CE; Marine; OrdLoc/HazLoc; ATEX/IECEx	
wago.com/750-600	

CE; Marine; OrdLoc/HazLoc	
wago.com/750-600	

This end module must be snapped onto the assembly at the end of a fieldbus node. The end module completes the internal data bus, ensuring flawless data transmission.

An end module must be snapped onto the assembly at the end of a fieldbus node. The end module completes the internal data bus, ensuring flawless data transmission.

An end module must be snapped onto the assembly at the end of a fieldbus node. In addition, the eight CAGE CLAMP® connections form a potential group. The end module completes the internal local data bus, ensuring flawless data transmission.



I/O System – 750 XTR Series

I/O System – 750 and 753 Series

- Highly versatile
- More than 500 modules available
- Functional safety
- Ex i

I/O System – 750 XTR Series

- For demanding applications in which the following are critical:
- Extreme temperature resistance
 - Immunity to electromagnetic interference and impulse voltages
 - Vibration and shock resistance

I/O System Field



- Automate and Network Modular Machines for the Future
- Ethernet-based fieldbus standards (EtherCAT®, EtherNet/IP™, PROFINET)
 - Integrated Bluetooth® interface (Android/iOS App), OPC UA Server, Webserver
 - IO-Link Master and Devices

◀ Section 7

Section 9 ▶▶

I/O System – 750 XTR Series

Contents

		Page	
	General Product Information	480	
	Interfaces and Types	481	
	Application and Installation Instructions	482	
	Standards and Rated Conditions for Railway Applications (EN 50155)	484	
	Standards and Rated Conditions	485	
	Item Number Key	484	
	Approvals	484	
	Controllers PFC200 XTR	See Section 6.2	
	Controllers 750 XTR	See Section 6.5	
	Description	Item No.	
	Fieldbus Coupler PROFIBUS DP; 2nd Generation; 12 MBd; Extreme	750-333/040-000 486	
	Fieldbus Coupler Modbus TCP; Extreme	750-362/040-000 487	
	Fieldbus Coupler Modbus TCP M12; 4th Generation; Extreme	750-364/040-010 488	
	Fieldbus Coupler EtherNet/IP™; Extreme	750-363/040-000 489	
	Fieldbus Coupler EtherNet/IP™ M12; 4th Generation; Extreme	750-365/040-010 490	
	Fieldbus Coupler CANopen; D-Sub; Extreme	750-338/040-000 491	
	8-Channel Digital Input; 24 VDC; 3 ms; 2-Wire Connection; Extreme	750-1415/040-000 492	
	8-Channel Digital Input; 24 VDC; 3 ms; Extreme	750-430/040-000 492	
	16-Channel Digital Input; 24 VDC; 3 ms; Extreme	750-1405/040-000 493	
	8-Channel Digital Input; 24 VDC; 0.2 ms; 2-Wire Connection; Extreme	750-1416/040-000 494	
	8-Channel Digital Input; 24 VDC; 0.2 ms; Extreme	750-431/040-000 495	
	8-Channel Digital Input; 24 VDC; 3 ms; Low-Side Switching; 2-Wire Connection; Extreme	750-1417/040-000 495	
	2-Channel Digital Input; 60 VDC; 3 ms; Extreme	750-429/040-001 496	
	2-Channel Digital Input; 110 VDC; 3 ms; Extreme	750-427/040-000 497	
	2-Channel Digital Input; 220 VDC; 3 ms; Extreme	750-407/040-000 498	
Digital Output Modules	2-Channel Digital Output; 24 VDC; 2.0 A; Diagnostics; Extreme	750-508/040-000 499	
	8-Channel Digital Output; 24 VDC; 0.5 A; Diagnostics; Extreme	750-537/040-000 500	
	8-Channel Digital Output; 24 VDC; 0.5 A; 2-Wire Connection; Extreme	750-1515/040-000 501	
	8-Channel Digital Output; 24 VDC; 0.5 A; Low-Side Switching; 2-Wire Connection; Extreme	750-1516/040-000 502	
	2-Channel Relay Output; 250 VAC; 1 A; Relay with 2 Changeover Contacts; Extreme	750-517/040-000 503	
Analog Input Modules	4-Channel Analog Input; 0 ... 20 mA; Single-Ended; Extreme	750-453/040-000 504	
	2-Channel Analog Input; 4 ... 20 mA; Differential Input; NAMUR NE 43; Extreme	750-492/040-001 505	
	4-Channel Analog Input; 4 ... 20 mA; Single-Ended; Extreme	750-455/040-000 506	
	4-Channel Analog Input; ±10 VDC; Single-Ended; Extreme	750-457/040-000 507	
	4-Channel Analog Input; 0 ... 10 VDC; Single-Ended; Extreme	750-468/040-000 508	
	2-Channel Analog Input; 0 ... 30 VDC; Differential Input; Extreme	750-483/040-000 509	
	4-Channel Analog Input; for Voltage/Current; Extreme	750-471/040-000 510	
	2/4-Channel Analog Input; Resistance Measurement; Adjustable; Extreme	750-464/040-000 511	
	2-Channel Analog Input; Thermocouple; Adjustable; Extreme	750-469/040-000 512	
	3-Phase Power Measurement; 20 kVAC; 300 A; Extreme	750-495/040-010 513	
	3-Phase Power Measurement; 690 VAC 1 A; Extreme	750-495/040-000 514	
	3-Phase Power Measurement; 690 VAC 5 A; Extreme	750-495/040-001 514	
	3-Phase Power Measurement; 690 VAC Rogowski Coils; Extreme	750-495/040-002 514	
Analog Output Modules	2-Channel Analog Output; 0/4 ... 20 mA; 16 Bits; 6 ... 18 VDC; Extreme	750-563/040-000 515	
	4-Channel Analog Output; ±10 VDC; Extreme	750-557/040-000 516	
	4-Channel Analog Output; 0 ... 10 VDC; Extreme	750-559/040-000 517	
Function/Technology Modules	Counter; Adjustable; Extreme	750-404/040-003 518	
	4-Channel Pulse-Width Modulation; 24 VDC; 0.2 A; 20 kHz; Extreme	750-677/040-000 519	
	Incremental Encoder Interface; 32 Bits; Extrem	750-637/040-00x 520	
	SSI Transmitter Interface; Adjustable; Extreme	750-630/040-001 521	
Communication Modules	Serial Interface RS-232/485; Extreme	750-652/040-000 522	
	CAN Gateway; Extreme	750-658/040-000 523	
Supply/Segment Modules	Power Supply; 24 VDC; Extreme	750-602/040-000 524	
	Power Supply; 24 VDC; Fuse Holder; Extreme	750-601/040-000 525	
	Power Supply; 24 VDC; Fuse Holder; Diagnostics; Extreme	750-610/040-000 526	
	Power Supply; 0 ... 230 VAC/DC; Extreme	750-612/040-000 527	
	System Power Supply; 24 VDC; Extreme	750-613/040-000 528	
	Potential Multiplication; 0 ... 230 VAC/DC; Extreme	750-614/040-000 529	
	Potential Multiplication; 16x 24 V; Extreme	750-1605/040-000 530	
	Potential Multiplication; 16x 0 V; Extreme	750-1606/040-000 531	
	Field Supply Filter (Surge); 24 VDC; Higher Isolation; Extreme	750-624/040-000 532	
	Field Supply Filter (Surge); 24 VDC; Higher Isolation; Without Power Jumper Contacts; Extreme	750-624/040-001 533	
	Supply Filter; 24 VDC; Higher Isolation; Extreme	750-626/040-000 534	
	Distance Module; Extreme	750-616/040-000 535	
	End Module; Extreme	750-600/040-00x 536	
	Intrinsically Safe XTR Modules	Power Supply; 24 VDC; Extreme; for Intrinsically Safe XTR Modules	750-606/040-000 539
		8-Channel Digital Input; NAMUR; Intrinsically Safe; Extreme	750-439/040-000 540
2-Channel Digital Output; 24 VDC; Intrinsically Safe; Extreme		750-535/040-000 541	
4-Channel Analog Input; 0/4 ... 20 mA; Intrinsically Safe; Extreme		750-486/040-000 542	
2-Channel Analog Input; 4 ... 20 mA HART; Intrinsically Safe; Extreme		750-484/040-000 543	
2-Channel Analog Input; Resistance Measurement; Intrinsically Safe; Extreme		750-481/040-000 544	
	2-Channel Analog Output; 0 ... 20 mA; Intrinsically Safe; Extreme	750-585/040-000 545	
	Up/Down Counter; Intrinsically Safe; Extreme	750-633/040-000 546	
Accessories Marking and Mounting Accessories		Section 13	

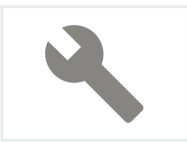

I/O System – 750 XTR Series

General Product Information

Taking It to the eXTReme – The Standard for 750 XTR

Instantly recognizable by its dark gray modules, you will benefit from the unique added value of the WAGO I/O System 750 XTR for applications that are subjected to extreme environments.

Extremely temperature-resistant, immune to interference, as well as unfazed by vibrations and impulse voltages – the WAGO I/O System 750 XTR is the first choice for demanding applications including:

- Marine systems and onshore/offshore installations
- Renewable energy systems (wind turbines, solar systems and biogas plants)
- Transformer stations and power distribution systems
- Petrochemical processing
- Water and wastewater treatment systems
- Custom machines
- Railway systems

Superior Reliability in Extreme Climates

Automation systems are increasingly being located in outdoor and remote locations where components are directly affected by widely fluctuating temperature conditions such as wind turbines or transformer stations.

Engineered for freezing cold, extreme heat and high humidity, the WAGO I/O System 750 XTR provides absolute dependability in virtually any weather. The XTR version of the WAGO I/O System 750 is unfazed by both freezing cold down to -40°C and scorching heat up to +70°C. And this applies equally for both start-up and ongoing operation.

The maximum approved operating altitude of 5,000 m is another highlight. Even in the thin air of a mountain-top station, the system impressively demonstrates its high performance and availability.

eXTReme Evolution of the Tried and Tested

Using an industry-leading platform, the WAGO I/O System 750 XTR boasts the same proven benefits:

- Compact design: up to 16 channels in a module width of 12 mm (1/2")
- Easy to use
- Vibration-proof, fast and maintenance-free CAGE CLAMP® spring connections
- Fieldbus independence due to its modular design
- Clear identification with the WAGO WSB Marking System

Additional Protection against Interference Pulses

The WAGO I/O System 750 XTR provides greater immunity to impulse voltages up to 5 kV, lower EMC emission of interference and higher insensitivity to EMC interference. These strengths ensure trouble-free operation.

High Mechanical Performance

Automation systems must be incredibly vibration-resistant, especially when installed close to vibration-prone and shock-generating system components. Powerful motors and power circuit breakers are just two examples of the many applications that can stress automation systems. To perform in these demanding environments, the WAGO I/O System 750 XTR was developed to set new standards. With 5g of vibration resistance per DIN EN 60068-2-6 (acceleration: 50 m/s²) and shock resistance of 15g (150 m/s²) or 25g (250 m/s²) per IEC 60068-2-27, the system is engineered for dependability – no matter what. Count on long-lasting, trouble-free operation and industry-topping levels of safety – even in the most severe applications, such as tunnel boring machines.

Worldwide Approvals

International approvals for industrial automation, marine automation and onshore/offshore applications guarantee worldwide use – even under harsh operating conditions, e.g., Germanischer Lloyd, Det Norske Veritas, American Bureau of Shipping, Korean Register of Shipping, Nippon Kaiji Kyokai, Registro Italiano Navale and Polski Rejestr Stratkow.



Benefits:

- No need for air conditioning
 - Requires less space
 - Lower energy and maintenance costs
- Can be used in unshielded areas
- Maximum system uptime
- Use on vibrating/shock-generating system components
- Vibration-proof, fast and maintenance-free CAGE CLAMP® connections

I/O System – 750 XTR Series Interfaces and Types

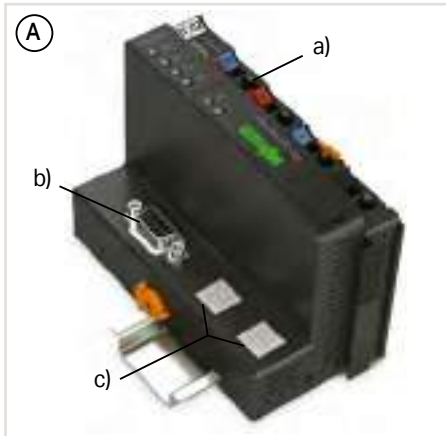

Housing Design: Fieldbus Coupler (A)

- Includes a supply module (a) to power downstream I/O modules
- Technical differences on the connection level; fieldbus interface (b) and optional addressing switch (c)
- W x H x D (mm): 50.5 x 100 x 71.1

Housing Design: Fieldbus Coupler Eco (B)

- Restriction on power supply and data width
- W x H x D (mm): 49.5 x 96.8 x 71.9

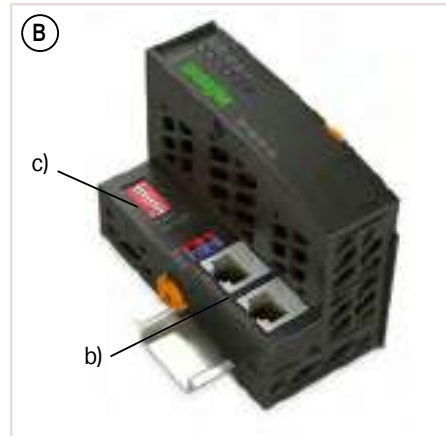

Housing Design: 750 (C)

- 8 connection points (CAGE CLAMP®)
- W x H x D (mm): 12 x 100 x 67.8

Housing Design: 750 (D)

- 16 connection points (Push-in CAGE CLAMP®)
- W x H x D (mm): 12 x 100 x 69



Housing Design: Double Width (E)

- Some modules are integrated into a double housing to address specific technological needs. Despite utilizing the same standardized housing, these modules are twice as wide.
- W x H x D (mm): 24 x 100 x 67.8

Specialty Housing Design (F)

- Some modules are integrated into a specialty housing with a specific width and pluggable connectors. The dimensions are specified on the respective catalog pages.



Housing Design: Intrinsically Safe XTR Modules (G)

- 8 connection points (CAGE CLAMP®)
- W x H x D (mm): 12 x 100 x 67.8

Housing Design (Intrinsically Safe XTR Modules): Double Width (H)

- 16 connection points (CAGE CLAMP®)
- W x H x D (mm): 24 x 100 x 67.8



I/O System – 750 XTR Series

Application and Installation Instructions



Securing/Removing a module from the DIN-rail



Secure, automatic data and electronics power supply connection via gold-plated pressure contacts



Service interface for configuring the fieldbus coupler; connectivity via configuration cable or radio adapter

8



Secure, automatic power supply connection via self-cleaning blade contacts

Notice:

Some I/O modules do not provide all power jumper contacts. Therefore, an I/O module with three power jumper contacts (e.g., 2-channel digital input) cannot be connected to an I/O module that do not have all power jumper contacts.

To increase electromagnetic compatibility (EMC), some components are connected to the DIN-rail via a discharge contact. The DIN-rail must always have a low-resistance connection to the ground potential.



Wide range of accessories available for EMC-compliant installation, including shield connection

Marking Accessories

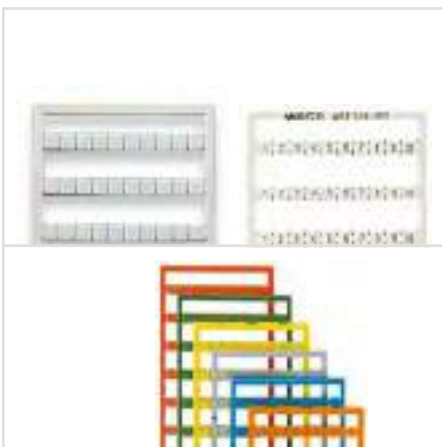

Mini-WSB marking cards (blank, pre-marked or colored) are suitable for all 750 Series I/O Modules.



Marker carrier for a single I/O module (suitable for all 750 and 753 Series I/O Modules); the marker carrier can be accommodated in the upper Mini-WSB marker slot.



Marker carrier for one I/O node; both models (750-106 and 750-107) permit continuous marking regardless of the I/O module housing used.

I/O System – 750 XTR Series

Application and Installation Instructions

Power Supply

The internal electronics are powered by the fieldbus coupler. The power supply to the field-side supply is electrically isolated. This division enables a separate supply for sensors and actuators. Snapping the I/O modules together automatically routes the supply voltages. Supply modules with diagnostics also enable power supply monitoring. This ensures a flexible and customized supply configuration for a fieldbus node. Power supply to the electronics is limited by a maximum value. This value depends on the fieldbus coupler used. If the sum of the internal current demand of all the I/O modules should exceed this value, an additional system supply module is necessary. Furthermore, the current consumed for field-side supply must not exceed 10 A. A variety of power supply modules allows re-feeding, creating potential groups and implementing emergency stops.

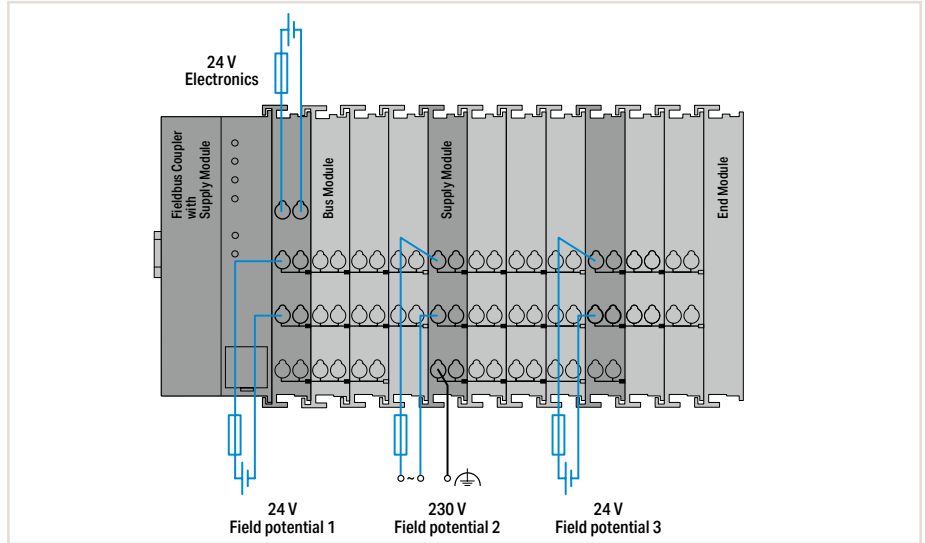

Interference-Free in Safety-Related Applications

To easily and safely perform a cost-effective and centralized deactivation of complete actuator groups, the actuator's power supply can be switched off using a safety switching device. This can either be performed for each individual actuator or by turning off the power supply to a group of control outputs. In the event of failure, ensure that no interference from other current or power circuits occurs – even when the control voltage is switched off – so the defined safety function properties (logic and time response) remain unchanged.

All 750 XTR Series Digital Output Modules are designed to provide interference-free safety functionality. The modules can be used in safety applications up to category 4 per DIN EN ISO 13849-1:2007. Safety category and performance level depend solely on the safety components and their wiring.

Notice:

WAGO's interference-free I/O modules are not a component of the safety function and do not replace the safety switching device! When using the components in safety functions, the corresponding notes must be observed in the relevant manual.

Notes:

Additional steps must be implemented based on where the I/O system is installed: Specific power and field-side power supply filters (750-624/040-001 or 750-626/040-000) are required for marine and onshore/offshore applications, as well as in telecontrol and railway systems.

A specific supply module (750-606/040-000) is required to operate intrinsically safe Ex i modules. Additionally, both supply modules and field-side power supply filters are recommended when operating intrinsically safe Ex i modules for marine and onshore/offshore applications.

Please refer to the manual for details about the power supply's design.

Mixed Operation

Mixed operation (standard/XTR modules) within a node is possible when groups of modules are electrically isolated on the field side (i.e., electrically isolated power supply). This combination may be useful, for example, when there are only increased requirements for immunity to impulse voltages and interference, but the surrounding air temperature is not critical.

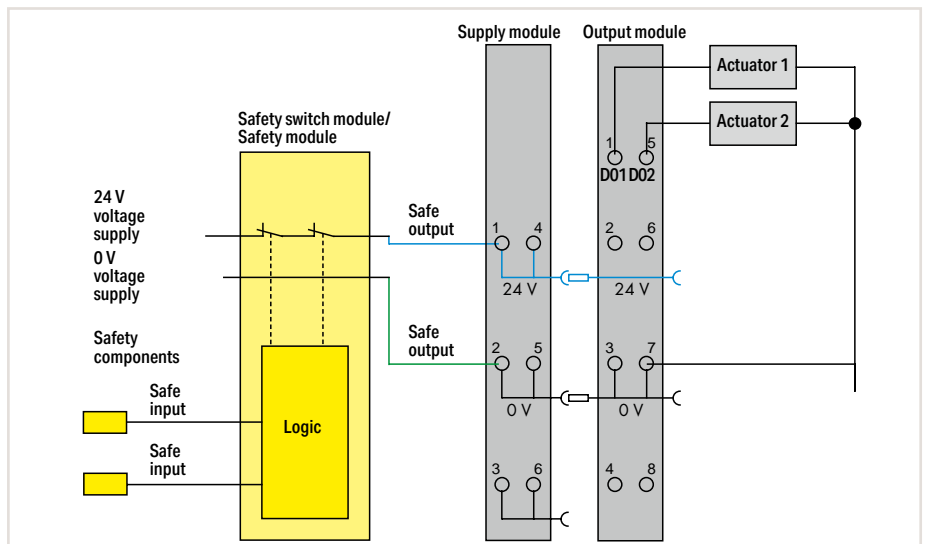

Example: 2-channel, double-pole power supply disconnection

I/O System – 750 XTR Series

Item Number Key

Explanation of an item number key's components

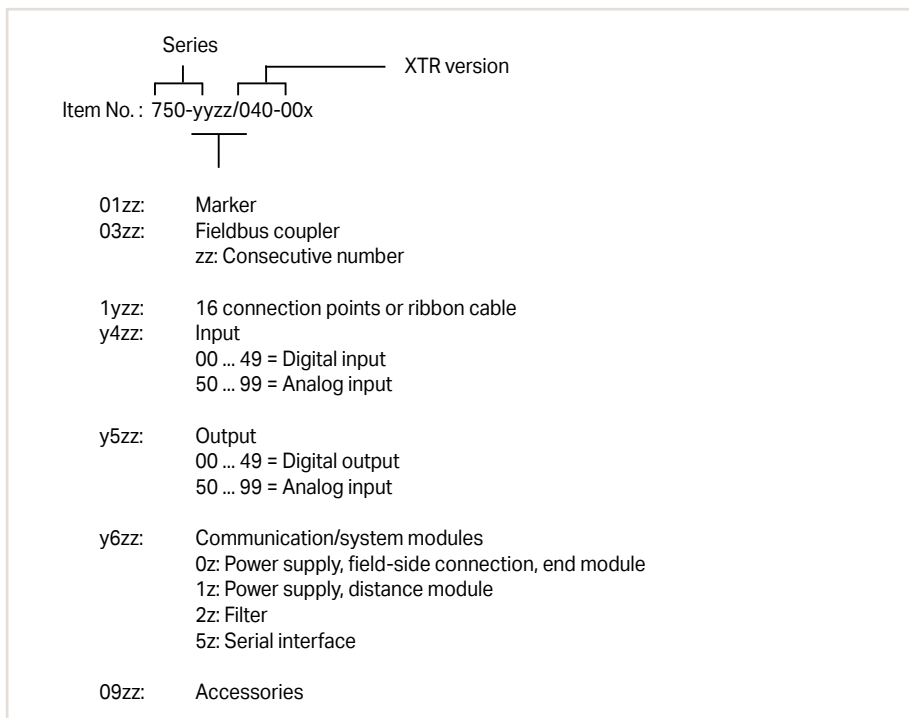

8

Approvals

For approvals overview (item comparison), see Section 14 (Technical Section) or visit www.wago.com.



Standards and Rated Conditions for Rail Applications (EN 50155), not for Intrinsically Safe XTR Modules

Railway Applications (EN 50155)	Class/Standard Compliance
4.1 Rated operating conditions	
4.1.1 Altitude above sea level	AX (EN 50125-1)
4.1.2 Surrounding air temperature	TX
4.1.3 Shock and vibration	1A and 1B (EN 61373)
4.1.4 Relative humidity	95 % (coated PCBs)
5.1 Power supply	
5.1.1.1 Voltage fluctuations	
Minimum voltage	0.725 x Un
Maximum voltage	1.3 x Un
5.1.1.2 Power interruptions	S1
5.4 Surge, ESD, burst tests	EN 50121-3-2
5.5 EMC (emission of interference, immunity to interference)	EN 50121-3-2, EN 50121-4, -5
Fire behavior: per EN 45545-2 hazard level HL3	
WAGO is certified in accordance with the IRIS quality standard.	

I/O System – 750 XTR Series

Standards and Rated Conditions

General technical data	
Ambient temperature (operation)	-40 ... +70 °C
Surrounding air temperature (storage)	-40 ... +85 °C
Relative humidity (without condensation)	95 %
Relative humidity (with condensation)	Short-term condensation per Class 3K7/IEC EN 60721-3-3 and E-DIN 40046-721-3 (except for wind-driven precipitation, water and ice formation)
Operating altitude	without temperature derating: 0 ... 2000 m; with temperature derating: 2000 ... 5000 m (0.5 K/100 m); 5000 m (max.)
Vibration resistance	per IEC 60068-2-6 (acceleration: 5g), EN 60870-2-2, IEC 60721-3-1, -3, EN 50155; EN 61373
Shock resistance	per IEC 60068-2-27 (15g/11 ms/half-sine/1,000 shocks; 25g/6 ms/1,000 shocks), EN 50155, EN 61373
Protection type	IP20
Mounting position	horizontal (standing/lying); vertical
Mounting type	DIN-35 rail
Housing material	Polycarbonate; polyamide 6.6
Exposure to pollutants	per IEC 60068-2-42 and IEC 60068-2-43

Cables and connectors	Page 680
Communication	Page 678
DIN-rail	Page 716
Marking	Page 714
Power supply	Page 539
Shield termination	Page 708
Supply module	Page 524
System enclosure	Page 693
Tool	Page 719

Fieldbus couplers ► PROFIBUS DP; 2nd generation



750-333/040-000

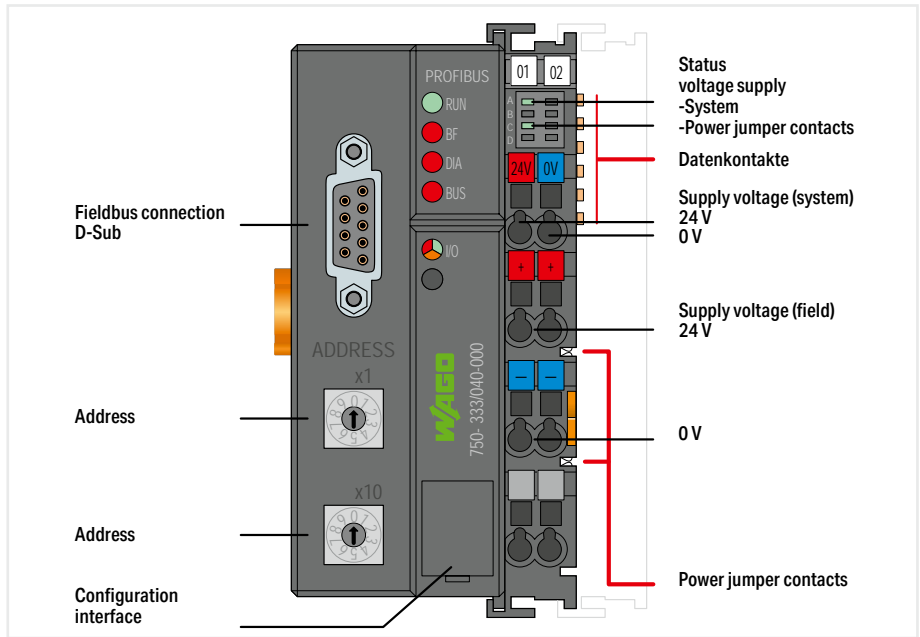

Version	extreme
Item no.	750-333/040-000
Order Text	FC PROFIBUS; G2; 12MBd; XTR

Version	extreme
Item no.	750-333/040-000
Order Text	FC PROFIBUS; G2; 12MBd; XTR

Technical data	
Communication	PROFIBUS
Protocols	PROFIBUS DP/V1
Connection technology: communication/fieldbus	PROFIBUS: 1 x D-sub 9 socket
Number of fieldbus nodes on master (max.)	96
Baud rate	9.6 kBd ... 12 MBd
Transmission medium (communication/fieldbus)	Cu cable per EN 50170
Number of modules per node (max.)	63
Input and output process image (fieldbus) max.	244 bytes/244 bytes
Supply voltage (system)	24 VDC; via pluggable connector (CAGE CLAMP® connection); Derating must be observed!
Supply voltage (field)	24 VDC; Power supply via pluggable connector (CAGE CLAMP® connection); Transmission via power jumper contacts; Derating must be observed!
Derating	Derating (supply voltage): Ambient temperatures under laboratory conditions: (-25 ... +30 %); for -40 ... +55 °C: 24 V (-25 ... +20 %); for +55 ... +70 °C: 24 V (-25 ... +10 %); Lower limit in all temperature ranges: -27.5 % (including 15 % residual ripple)
Input current (typ.) at nominal load (24 V)	500 mA
Current consumption (5 V system supply)	200 mA
Total current (system supply)	1800 mA
Rated surge voltage	1 kV
Ambient temperature (operation)	-40 ... +70 °C
Dimensions W x H x D	(50.5 x 100 x 71.1) mm
Approvals	CE, Marine, OrdLoc/HazLoc, ATEX/IECEX

Technical data	
Communication	PROFIBUS
Protocols	PROFIBUS DP/V1
Connection technology: communication/fieldbus	PROFIBUS: 1 x D-sub 9 socket
Number of fieldbus nodes on master (max.)	96
Baud rate	9.6 kBd ... 12 MBd
Transmission medium (communication/fieldbus)	Cu cable per EN 50170
Number of modules per node (max.)	63
Input and output process image (fieldbus) max.	244 bytes/244 bytes
Supply voltage (system)	24 VDC; via pluggable connector (CAGE CLAMP® connection); Derating must be observed!
Supply voltage (field)	24 VDC; Power supply via pluggable connector (CAGE CLAMP® connection); Transmission via power jumper contacts; Derating must be observed!
Derating	Derating (supply voltage): Ambient temperatures under laboratory conditions: (-25 ... +30 %); for -40 ... +55 °C: 24 V (-25 ... +20 %); for +55 ... +70 °C: 24 V (-25 ... +10 %); Lower limit in all temperature ranges: -27.5 % (including 15 % residual ripple)
Input current (typ.) at nominal load (24 V)	500 mA
Current consumption (5 V system supply)	200 mA
Total current (system supply)	1800 mA
Rated surge voltage	1 kV
Ambient temperature (operation)	-40 ... +70 °C
Dimensions W x H x D	(50.5 x 100 x 71.1) mm
Approvals	CE, Marine, OrdLoc/HazLoc, ATEX/IECEX

For data sheet and additional information, see:

wago.com/750-333/040-000

Fieldbus couplers ▶ Modbus TCP; ECO



750-362/040-000

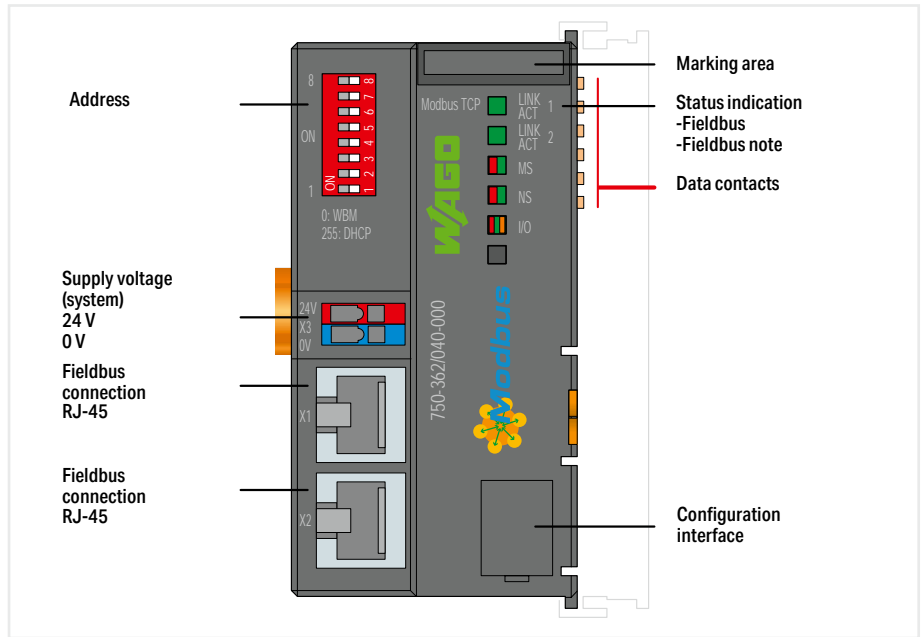

Version	
Item no.	
Order Text	

extreme
750-362/040-000
FC Modbus TCP; G4; XTR

Technical data	
Communication	
ETHERNET protocols	
Connection technology: communication/fieldbus	
Baud rate	
Transmission medium (communication/fieldbus)	
Transmission performance	
Number of modules per node (max.)	
Input and output process image (fieldbus) max.	
Supply voltage (system)	
Derating	
Input current (typ.) at nominal load (24 V)	
Current consumption (5 V system supply)	
Total current (system supply)	
Rated surge voltage	
Ambient temperature (operation)	
Dimensions W x H x D	
Approvals	
For data sheet and additional information, see:	

Modbus (TCP, UDP)
HTTP(S); BootP; DHCP; DNS; SNMP; FTP(S); SNMP
Modbus (TCP, UDP); 2 x RJ-45
10/100 Mbit/s
Twisted pair S-UTP; 100 Ω; Cat. 5; 100 m maximum cable length
Class D per EN 50173
64
1020 words/1020 words
24 VDC; via pluggable connector (CAGE CLAMP® connection); Derating must be observed!
Derating (supply voltage): Ambient temperatures under laboratory conditions: (-25 ... +30 %); for -40 ... +55 °C: 24 V (-25 ... +20 %); for +55 ... +70 °C: 24 V (-25 ... +10 %); Lower limit in all temperature ranges: -27.5 % (including 15 % residual ripple)
280 mA
350 mA
700 mA
1 kV
-40 ... +70 °C
(49.5 x 96.8 x 71.9) mm
CE; Marine; OrdLoc/HazLoc; ATEX/IECEX
wago.com/750-362/040-000

Fieldbus couplers ► Modbus TCP M12



750-364/040-010

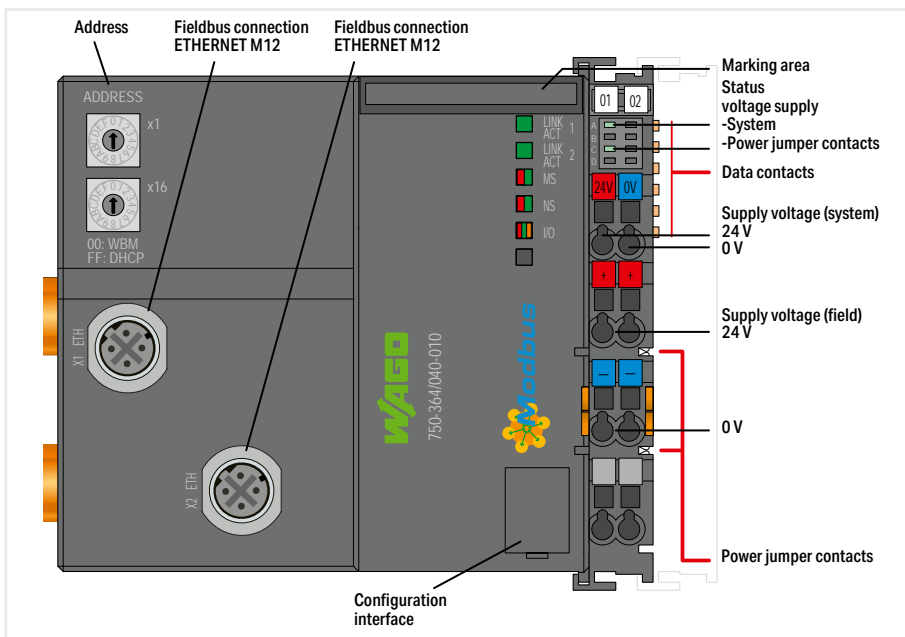

Version	extreme
Item no.	750-364/040-010
Order Text	FC Modbus TCP M12; G4; XTR

Technical data	
Communication	Modbus (TCP, UDP)
ETHERNET protocols	HTTP(S); BootP; DHCP; DNS; FTP(S); SNMP
Connection technology: communication/fieldbus	Modbus (TCP, UDP); 2 x M12 socket; 4-pole; D-coded
Baud rate	10/100 Mbit/s
Transmission medium (communication/fieldbus)	Twisted pair S-UTP; 100 Ω; Cat. 5; M12 D-coded; 100 m maximum cable length
Transmission performance	Class D per EN 50173
Number of modules per node (max.)	64
Input and output process image (fieldbus) max.	1020 words/1020 words
Supply voltage (system)	24 VDC; via pluggable connector (CAGE CLAMP® connection); Derating must be observed!
Supply voltage (field)	24 VDC; Power supply via pluggable connector (CAGE CLAMP® connection); Transmission via power jumper contacts; Derating must be observed!
Derating	Derating (supply voltage): Ambient temperatures under laboratory conditions: (-25 ... +30 %); for -40 ... +55 °C: 24 V (-25 ... +20 %); for +55 ... +70 °C: 24 V (-25 ... +10 %); Lower limit in all temperature ranges: -27.5 % (including 15 % residual ripple)
Input current (typ.) at nominal load (24 V)	500 mA
Current consumption (5 V system supply)	350 mA
Total current (system supply)	1700 mA
Rated surge voltage	1 kV
Ambient temperature (operation)	-40 ... +70 °C
Dimensions W x H x D	(112 x 100 x 71.9) mm
Approvals	CE; Marine; OrdLoc/HazLoc; ATEX/IECEX

For data sheet and additional information, see:

wago.com/750-364/040-010

Fieldbus couplers ▶ EtherNet/IP™; ECO



750-363/040-000

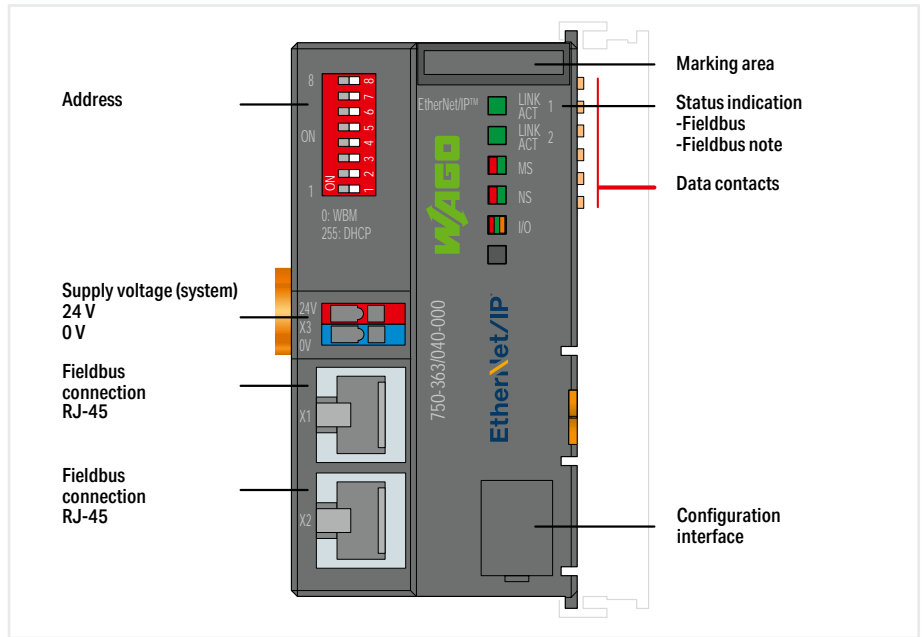

Version	
Item no.	
Order Text	

extreme
750-363/040-000
FC EtherNet/IP™; G4; XTR

Technical data	
Communication	
ETHERNET protocols	
Connection technology: communication/fieldbus	
Baud rate	
Transmission medium (communication/fieldbus)	
Transmission performance	
Number of modules per node (max.)	
Input and output process image (fieldbus) max.	
Supply voltage (system)	
Derating	
Input current (typ.) at nominal load (24 V)	
Current consumption (5 V system supply)	
Total current (system supply)	
Rated surge voltage	
Ambient temperature (operation)	
Dimensions W x H x D	
Approvals	
For data sheet and additional information, see:	

	EtherNet/IP™
	HTTP(S); BootP; DHCP; DNS; SNMP; FTP(S); SNMP
	EtherNet/IP™: 2 x RJ-45
	10/100 Mbit/s
	Twisted pair S-UTP; 100 Ω; Cat. 5; 100 m maximum cable length
	Class D per EN 50173
	64
	1020 words/1020 words
	24 VDC; via pluggable connector (CAGE CLAMP® connection); Derating must be observed!
	Derating (supply voltage): Ambient temperatures under laboratory conditions: (-25 ... +30 %); for -40 ... +55 °C: 24 V (-25 ... +20 %); for +55 ... +70 °C: 24 V (-25 ... +10 %); Lower limit in all temperature ranges: -27.5 % (including 15 % residual ripple)
	280 mA
	350 mA
	700 mA
	1 kV
	-40 ... +70 °C
	(49.5 x 96.8 x 71.9) mm
	CE; Marine; OrdLoc/HazLoc; ATEX/IECEX
	wago.com/750-363/040-000

Fieldbus couplers ▶ EtherNet/IP™ M12



750-365/040-010

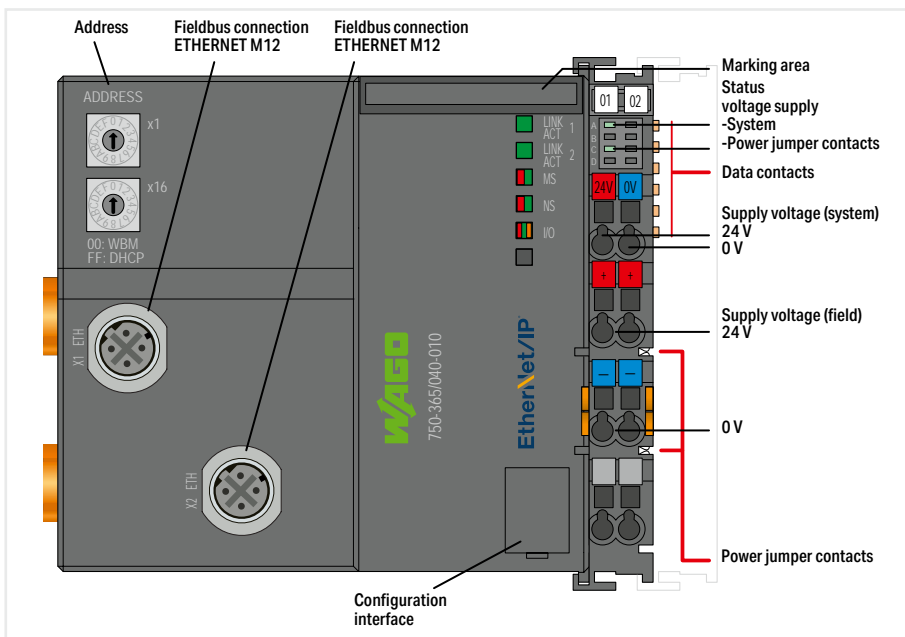

Version
Item no.
Order Text

extreme
750-365/040-010
FC EtherNet/IP™ M12; G4; XTR

Technical data
Communication
ETHERNET protocols
Connection technology: communication/fieldbus
Baud rate
Transmission medium (communication/fieldbus)
Transmission performance
Number of modules per node (max.)
Input and output process image (fieldbus) max.
Supply voltage (system)
Supply voltage (field)
Derating
Input current (typ.) at nominal load (24 V)
Current consumption (5 V system supply)
Total current (system supply)
Rated surge voltage
Ambient temperature (operation)
Dimensions W x H x D
Approvals

EtherNet/IP™
HTTP(S); BootP; DHCP; DNS; FTP(S); SNMP
EtherNet/IP™: 2 x M12 socket; 4-pole; D-coded
10/100 Mbit/s
Twisted pair S-UTP; 100 Ω; Cat. 5; M12 D-coded; 100 m maximum cable length
Class D per EN 50173
64
1020 words/1020 words
24 VDC; via pluggable connector (CAGE CLAMP® connection); Derating must be observed!
24 VDC; Power supply via pluggable connector (CAGE CLAMP® connection); Transmission via power jumper contacts; Derating must be observed!
Derating (supply voltage): Ambient temperatures under laboratory conditions: (-25 ... +30 %); for -40 ... +55 °C: 24 V (-25 ... +20 %); for +55 ... +70 °C: 24 V (-25 ... +10 %); Lower limit in all temperature ranges: -27.5 % (including 15 % residual ripple)
500 mA
350 mA
1700 mA
1 kV
-40 ... +70 °C
(112 x 100 x 71.9) mm
CE; Marine; OrdLoc/HazLoc; ATEX/IECEX

For data sheet and additional information, see:

wago.com/750-365/040-010

Fieldbus couplers ▶ CANopen

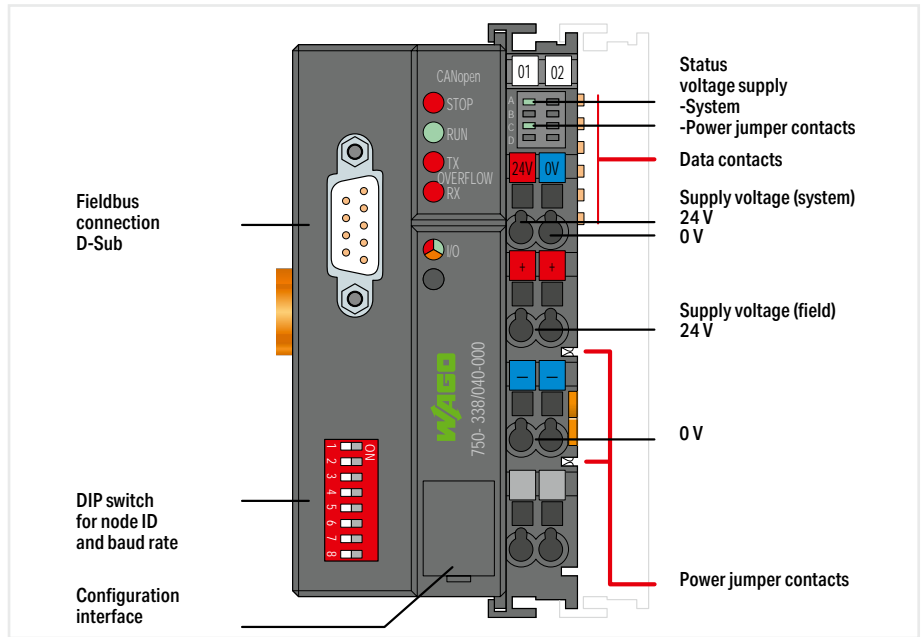

Version	extreme
Item no.	750-338/040-000
Order Text	FC CANopen; DSub; XTR
Technical data	
Communication	CANopen
Connection technology: communication/fieldbus	CANopen: 1 x D-sub 9 plug
Number of fieldbus nodes on master (max.)	110
Baud rate	10 kBd ... 1 MBd
Transmission medium (communication/fieldbus)	Shielded Cu cable 3 x 0.25 mm ²
Number of modules per node (max.)	64
Input and output process image (fieldbus) max.	512 bytes/512 bytes
Number of PDOs	32 Tx / 32 Rx
Number of SDOs	2 SDO servers
Communication profile	DS-301 V4.1
Device profile	DS-401 V2.0; Limit value monitoring ; Edge-triggered PDOs; Configurable response in the event of an error
Supply voltage (system)	24 VDC; via pluggable connector (CAGE CLAMP® connection); Derating must be observed!
Supply voltage (field)	24 VDC; Power supply via pluggable connector (CAGE CLAMP® connection); Transmission via power jumper contacts; Derating must be observed!
Derating	Derating (supply voltage): Ambient temperatures under laboratory conditions: (-25 ... +30 °C); for -40 ... +55 °C: 24 V (-25 ... +20 %); for +55 ... +70 °C: 24 V (-25 ... +10 %); Lower limit in all temperature ranges: -27.5 % (including 15 % residual ripple)
Input current (typ.) at nominal load (24 V)	500 mA
Current consumption (5 V system supply)	350 mA
Total current (system supply)	1650 mA
Rated surge voltage	1 kV
Ambient temperature (operation)	-40 ... +70 °C
Dimensions W x H x D	(50.5 x 100 x 71.1) mm
Approvals	CE; Marine; OrdLoc/HazLoc; ATEX/IECEX
For data sheet and additional information, see:	wago.com/750-338/040-000

Digital input ▶ 24 VDC ▶ high-side switching ▶ 3 ms



750-430/040-000

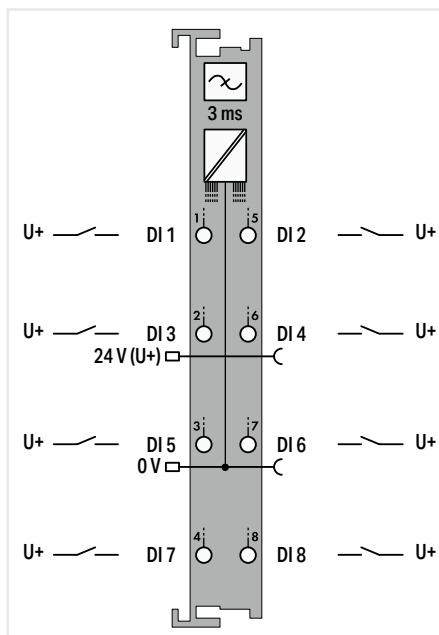

8-Channel Digital Input; 24 VDC; 3 ms

extreme

750-430/040-000

8DI; 24 VDC; 3ms; XTR

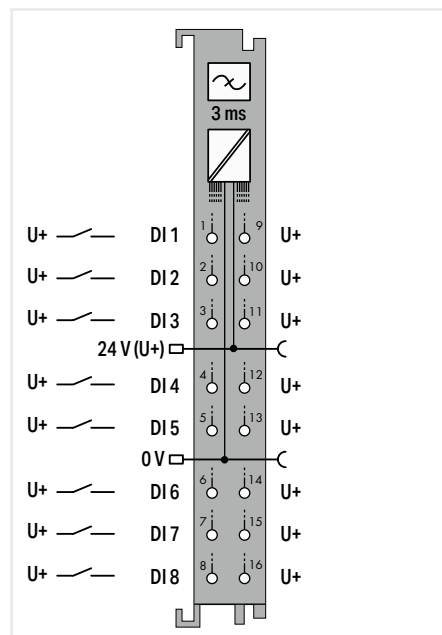

8-Channel Digital Input; 24 VDC; 3 ms; 2-wire connection

extreme with 16 connectors

750-1415/040-000

8DI; 24 VDC; 3ms; 2-wire; XTR

Item description

Version

Item no.

Order Text

Technical data

Number of digital inputs

Signal type

Signal type (voltage)

Voltage range for signal (0)

Voltage range for signal (1)

Input characteristic

Sensor connection

Input characteristic

Input filter (digital)

Input current per channel for signal (1) typ.

Input current per channel for signal (0) typ.

Dielectric strength

Current consumption, field supply (module with no external load)

Supply voltage (sensor)

Supply voltage (field)

Derating

Current consumption (5 V system supply)

Rated surge voltage

Input data width (internal) max.

Ambient temperature (operation)

Dimensions W x H x D

Approvals

For data sheet and additional information, see:

8

Digital

24 VDC

-3 ... +5 VDC

15 ... 30 VDC

-

8 x (1-wire)

high-side switching

3 ms

2.8 mA

-

510 VAC/775 VDC; per EN 60870-2-1

-

24 VDC (-25 ... +30 %); via power jumper contacts (power supply via blade contact; transmission via spring contact); Derating must be observed!

Derating (supply voltage): Ambient temperatures under laboratory conditions: (-25 ... +30 %); for -40 ... +55 °C: 24 V (-25 ... +20 %); for +55 ... +70 °C: 24 V (-25 ... +10 %); Lower limit in all temperature ranges: -27.5 % (including 15 % residual ripple)

17 mA

1 kV

8 bits

-40 ... +70 °C

(12 x 100 x 67.8) mm

CE; Marine; OrdLoc/HazLoc; ATEX/IECEX

wago.com/750-430/040-000

8

Digital

24 VDC

-3 ... +5 VDC

11 ... 30 VDC

Type 3

8 x (2-wire)

high-side switching

3 ms

4.5 mA

1.6 mA

510 VAC/775 VDC; per EN 60870-2-1

2 mA

24 VDC (-25 ... +30 %); via power jumper contacts (power supply via blade contact; transmission via spring contact); Derating must be observed!

Derating (supply voltage): Ambient temperatures under laboratory conditions: (-25 ... +30 %); for -40 ... +55 °C: 24 V (-25 ... +20 %); for +55 ... +70 °C: 24 V (-25 ... +10 %); Lower limit in all temperature ranges: -27.5 % (including 15 % residual ripple)

6 mA

1 kV

8 bits

-40 ... +70 °C

(12 x 100 x 69) mm

CE; Marine; OrdLoc/HazLoc; ATEX/IECEX

wago.com/750-1415/040-000

Digital input ▶ 24 VDC ▶ high-side switching ▶ 3 ms



750-1405/040-000

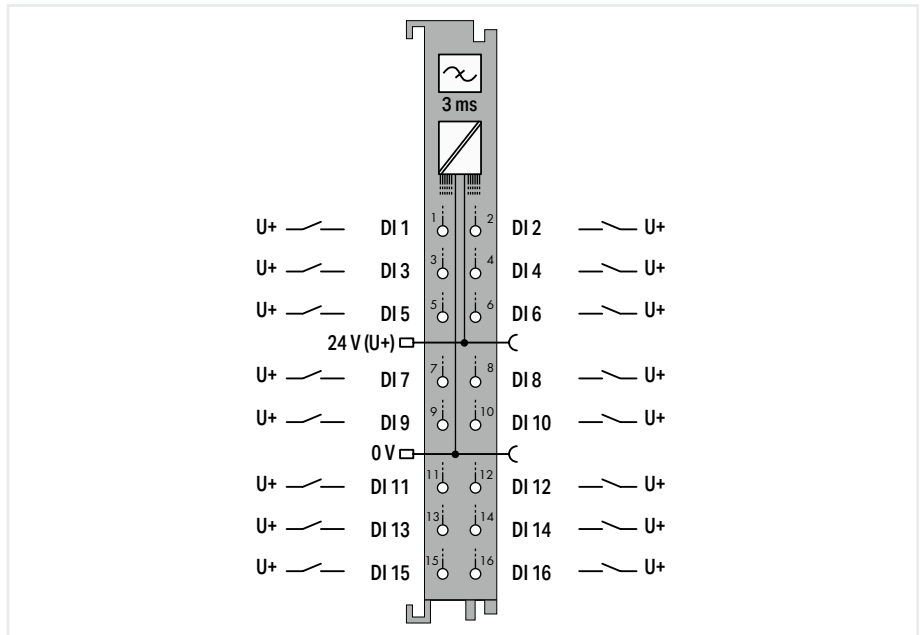

Item description	16-Channel Digital Input; 24 VDC; 3 ms
Version	extreme with 16 connectors
Item no.	750-1405/040-000
Order Text	16DI; 24 VDC; 3ms; XTR
Technical data	
Number of digital inputs	16
Signal type	Digital
Signal type (voltage)	24 VDC
Voltage range for signal (0)	-3 ... +5 VDC
Voltage range for signal (1)	15 ... 30 VDC
Input characteristic	Type 1
Sensor connection	16 x (1-wire)
Input characteristic	high-side switching
Input filter (digital)	3 ms
Delay time T _{off} from 1 to 0	400 μs
Delay time T _{on} from 0 to 1	300 μs
Input current per channel for signal (1) typ.	2.3 mA
Input current per channel for signal (0) typ.	0.6 mA
Dielectric strength	510 VAC/775 VDC; per EN 60870-2-1
Supply voltage (field)	24 VDC (-25 ... +30 %); via power jumper contacts (power supply via blade contact; transmission via spring contact); Derating must be observed!
Derating	
Derating (supply voltage): Ambient temperatures under laboratory conditions: (-25 ... +30 °C); for -40 ... +55 °C: 24 V (-25 ... +20 %); for +55 ... +70 °C: 24 V (-25 ... +10 %); Lower limit in all temperature ranges: -27.5 % (including 15 % residual ripple)	
Current consumption (5 V system supply)	25 mA
Rated surge voltage	1 kV
Input data width (internal) max.	16 bits
Ambient temperature (operation)	-40 ... +70 °C
Dimensions W x H x D	(12 x 100 x 69) mm
Approvals	CE; Marine; OrdLoc/HazLoc; ATEX/IECEX

For data sheet and additional information, see:

wago.com/750-1405/040-000

Digital input ▶ 24 VDC ▶ high-side switching ▶ 0.2 ms



750-431/040-000

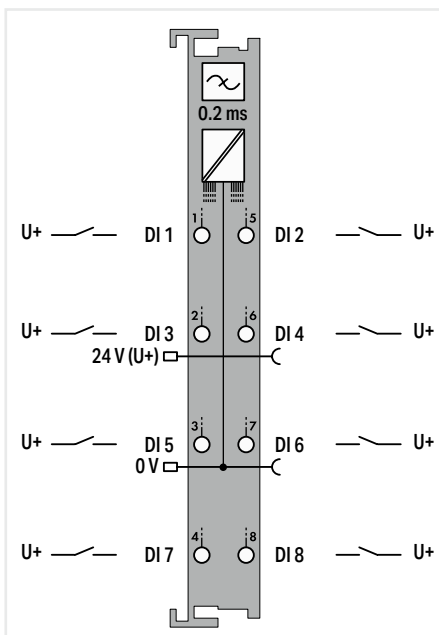

8-Channel Digital Input; 24 VDC; 0.2 ms

extreme

750-431/040-000

8DI; 24 VDC; 0.2ms; XTR

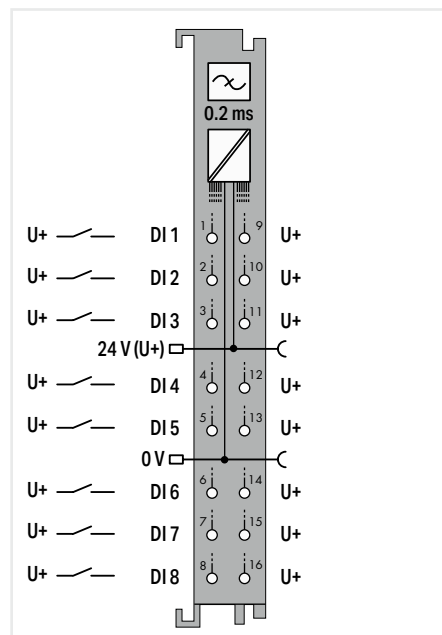

8-Channel Digital Input; 24 VDC; 0.2 ms; 2-wire connection

extreme with 16 connectors

750-1416/040-000

8DI; 24 VDC; 0.2ms; 2-wire; XTR

Item description

Version

Item no.

Order Text

Technical data

Number of digital inputs

Signal type

Signal type (voltage)

Voltage range for signal (0)

Voltage range for signal (1)

Input characteristic

Sensor connection

Input characteristic

Input filter (digital)

Input current per channel for signal (1) typ.

Input current per channel for signal (0) typ.

Dielectric strength

Current consumption, field supply (module with no external load)

Supply voltage (sensor)

Supply voltage (field)

Derating

Current consumption (5 V system supply)

Rated surge voltage

Input data width (internal) max.

Ambient temperature (operation)

Dimensions W x H x D

Approvals

For data sheet and additional information, see:

8

Digital

24 VDC

-3 ... +5 VDC

15 ... 30 VDC

-

8 x (1-wire)

high-side switching

0.2 ms

2.8 mA

-

510 VAC/775 VDC; per EN 60870-2-1

-

24 VDC (-25 ... +30 %); via power jumper contacts (power supply via blade contact; transmission via spring contact); Derating must be observed!

Derating (supply voltage): Ambient temperatures under laboratory conditions: (-25 ... +30 %); for -40 ... +55 °C: 24 V (-25 ... +20 %); for +55 ... +70 °C: 24 V (-25 ... +10 %); Lower limit in all temperature ranges: -27.5 % (including 15 % residual ripple)

17 mA

1 kV

8 bits

-40 ... +70 °C

(12 x 100 x 67.8) mm

CE; Marine; OrdLoc/HazLoc; ATEX/IECEX

wago.com/750-431/040-000

8

Digital

24 VDC

-3 ... +5 VDC

11 ... 30 VDC

Type 3

8 x (2-wire)

high-side switching

0.2 ms

4.5 mA

1.6 mA

510 VAC/775 VDC; per EN 60870-2-1

2 mA

24 VDC (-25 ... +30 %); via power jumper contacts (power supply via blade contact; transmission via spring contact); Derating must be observed!

Derating (supply voltage): Ambient temperatures under laboratory conditions: (-25 ... +30 %); for -40 ... +55 °C: 24 V (-25 ... +20 %); for +55 ... +70 °C: 24 V (-25 ... +10 %); Lower limit in all temperature ranges: -27.5 % (including 15 % residual ripple)

6 mA

1 kV

8 bits

-40 ... +70 °C

(12 x 100 x 69) mm

CE; Marine; OrdLoc/HazLoc; ATEX/IECEX

wago.com/750-1416/040-000

Digital input ▶ 24 VDC ▶ low-side switching ▶ 3 ms



750-1417/040-000

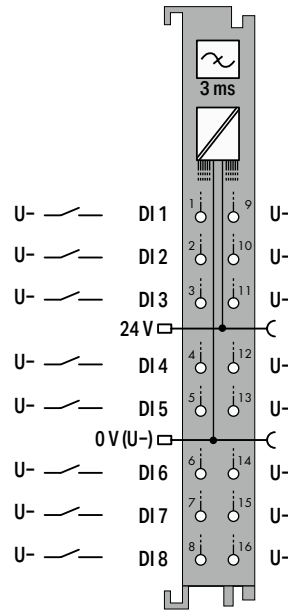

Item description	8-Channel Digital Input; 24 VDC; 3 ms; Low-Side Switching; 2-Wire Connection
Version	extreme with 16 connectors
Item no.	750-1417/040-000
Order Text	8DI; 24 VDC; 3ms; LSS; 2-wire; XTR
Technical data	
Number of digital inputs	8
Signal type	Digital
Signal type (voltage)	24 VDC
Voltage range for signal (0)	($U_V - 5 V$) ... U_V DC
Voltage range for signal (1)	-3 VDC ... ($U_V - 15 V$)
Sensor connection	8 x (2-wire)
Input characteristic	low-side switching
Input filter (digital)	3 ms
Input current per channel for signal (0) typ.	-2.4 mA
Dielectric strength	510 VAC/775 VDC; per EN 60870-2-1
Supply voltage (sensor)	24 VDC
Supply voltage (field)	24 VDC (-25 ... +30 %); via power jumper contacts (power supply via blade contact; transmission via spring contact); Derating must be observed!
Derating	Derating (supply voltage): Ambient temperatures under laboratory conditions: (-25 ... +30 %); for -40 ... +55 °C: 24 V (-25 ... +20 %); for +55 ... +70 °C: 24 V (-25 ... +10 %); Lower limit in all temperature ranges: -27.5 % (including 15 % residual ripple)
Current consumption (5 V system supply)	12 mA
Rated surge voltage	1 kV
Input data width (internal) max.	8 bits
Ambient temperature (operation)	-40 ... +70 °C
Dimensions W x H x D	(12 x 100 x 69) mm
Approvals	CE; Marine; OrdLoc/HazLoc
For data sheet and additional information, see:	wago.com/750-1417/040-000

Digital input ▶ 60 VDC ▶ high-side/low-side switching, configurable ▶ 3 ms



750-429/040-001

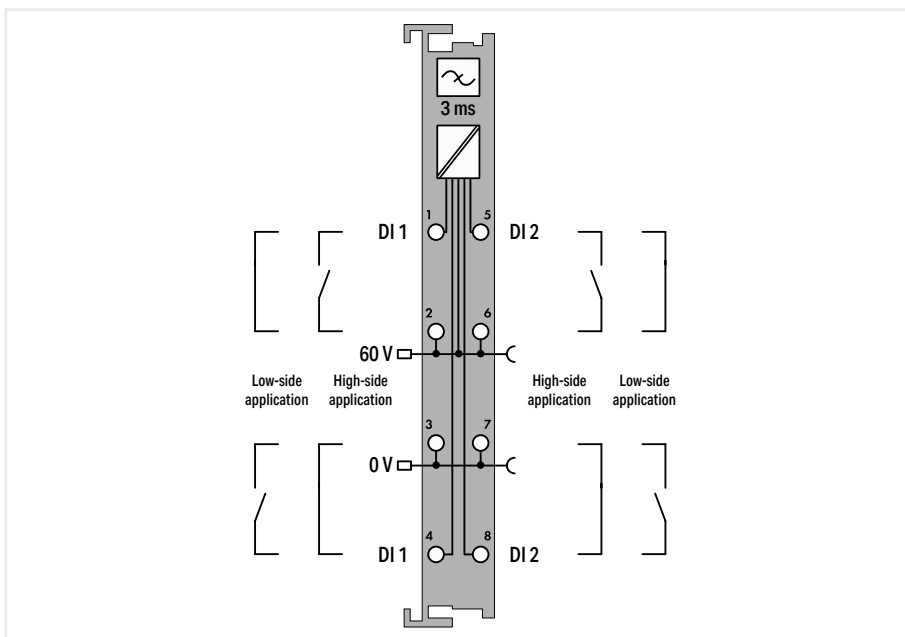

Item description	2-Channel Digital Input; 60 VDC; 3 ms
Version	extreme
Item no.	750-429/040-001
Order Text	2DI; 60 VDC; 3ms; XTR
Technical data	
Number of digital inputs	2
Signal type	Digital
Signal type (voltage)	60 VDC
Voltage range for signal (0)	-7.5 ... +12 VDC
Voltage range for signal (1)	44 ... 78 VDC
Sensor connection	2 x (2-wire)
Input characteristic	high-side/low-side switching, configurable
Input filter (digital)	3 ms
Input current per channel for signal (1) typ.	2.9 mA
Dielectric strength	2.5 kV (AC)/3.5 kV (DC); per EN 60870-2-1
Supply voltage (sensor)	60 VDC
Supply voltage (field)	60 VDC (-25 ... +30 %); via power jumper contacts (power supply via blade contact; transmission via spring contact)
Current consumption (5 V system supply)	2.5 mA
Rated surge voltage	5.0 kV (EN 60870-2-1 / Class VW3); 4.0 kV (UL 508); 4.0 kV (EN 61010-1 to 2000 m); 2.5 kV (EN 61010-1 to 5000 m)
Overvoltage category	Nominal voltage 110 V: III (EN 61010-1 / up to 2.000 m); II (EN 61010-1 / up to 5.000 m)
Input data width (internal) max.	2 bits
Ambient temperature (operation)	-40 ... +70 °C
Dimensions W x H x D	(12 x 100 x 67.8) mm
Approvals	CE; Marine; OrdLoc/HazLoc; ATEX/IECEX
For data sheet and additional information, see:	wago.com/750-429/040-001

Notice: An additional supply module must be added for 60 VDC supply!

Digital input ▶ 110 VDC ▶ high-side/low-side switching, configurable ▶ 3 ms



750-427/040-000

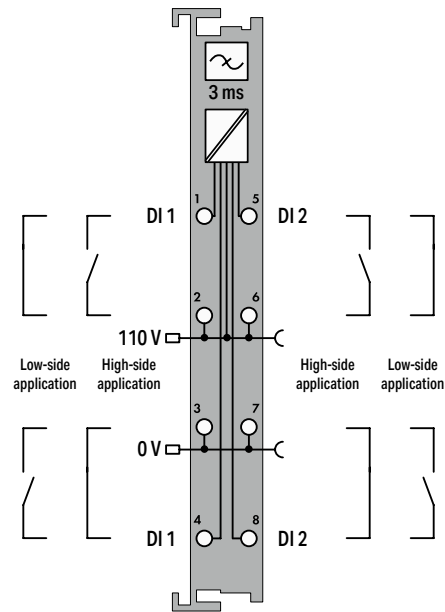

Item description	2-Channel Digital Input; 110 VDC; 3 ms
Version	extreme
Item no.	750-427/040-000
Order Text	2DI; 110 VDC; 3ms; XTR
Technical data	
Number of digital inputs	2
Signal type	Digital
Signal type (voltage)	110 VDC
Voltage range for signal (0)	-14 ... +50 VDC
Voltage range for signal (1)	70 ... 143 VDC
Sensor connection	2 x (2-wire)
Input characteristic	high-side/low-side switching, configurable
Input filter (digital)	3 ms
Input current per channel for signal (1) typ.	2.5 mA
Dielectric strength	2.5 kV (AC)/3.5 kV (DC); per EN 60870-2-1
Supply voltage (sensor)	110 VDC
Supply voltage (field)	110 VDC (-25 ... +30 %); via power jumper contacts (power supply via blade contact; transmission via spring contact)
Current consumption (5 V system supply)	2.5 mA
Rated surge voltage	5.0 kV (EN 60870-2-1 / Class VW3); 4.0 kV (UL 508); 4.0 kV (EN 61010-1 to 2000 m); 2.5 kV (EN 61010-1 to 5000 m)
Overvoltage category	Nominal voltage 110 V: III (EN 61010-1 / up to 2.000 m); II (EN 61010-1 / up to 5.000 m)
Input data width (internal) max.	2 bits
Ambient temperature (operation)	-40 ... +70 °C
Dimensions W x H x D	(12 x 100 x 67.8) mm
Approvals	CE; Marine; OrdLoc/HazLoc; ATEX/IECEX
For data sheet and additional information, see:	wago.com/750-427/040-000

Notice: An additional supply module must be added for 110 VDC supply!

Digital input ▶ 220 VDC ▶ high-side switching ▶ 3 ms



750-407/040-000

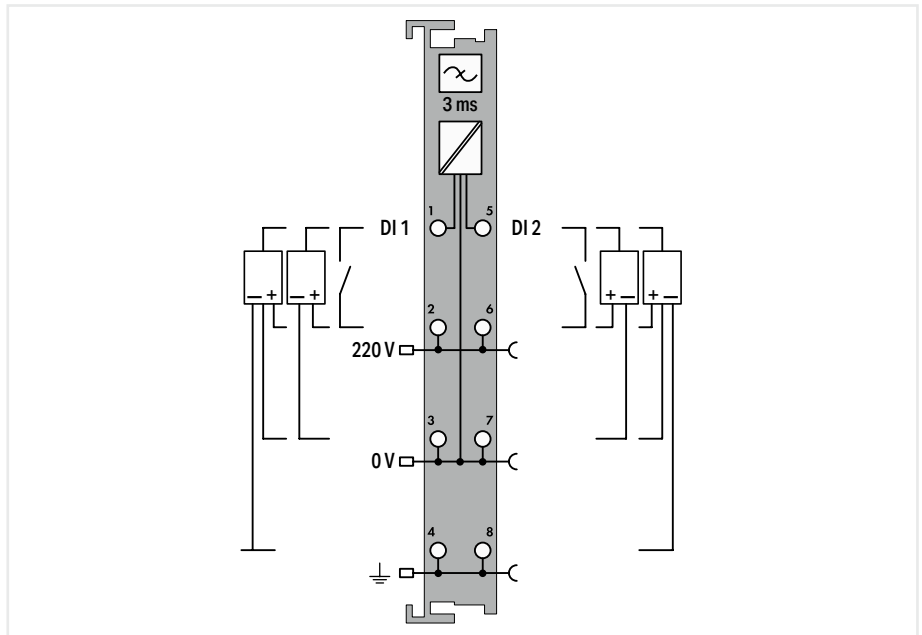

Item description	2-Channel Digital Input; 220 VDC; 3 ms
Version	extreme
Item no.	750-407/040-000
Order Text	2DI; 220 VDC; 3ms; XTR
Technical data	
Number of digital inputs	2
Signal type	Digital
Signal type (voltage)	220 VDC
Voltage range for signal (0)	-3 ... +100 VDC
Voltage range for signal (1)	160 ... 286 VDC
Sensor connection	2 x (2-wire, 3-wire, 4-wire)
Input characteristic	high-side switching
Input filter (digital)	3 ms
Input current per channel for signal (1) typ.	1.2 mA
Dielectric strength	2.5 kV (AC)/3.5 kV (DC); per EN 60870-2-1
Supply voltage (sensor)	220 VDC
Supply voltage (field)	220 VDC (-20 ... +25 %); via power jumper contacts (power supply via blade contact; transmission via spring contact)
Derating	Current via power jumper contacts (max.): 10 mA (surrounding air (operating) temperature < 60 °C); 8 A (surrounding air (operating) temperature: 60 ... 70 °C)
Current consumption (5 V system supply)	5 mA
Rated surge voltage	5.0 kV (EN 60870-2-1 / Class VW3); 4.0 kV (UL 508); 4.0 kV (EN 60664-1 / to 4,000 m ASL); 2.5 kV (EN 60664-1 / > 4,000 m to 5,000 m ASL)
Overvoltage category	Nominal voltage 220 V: IV (EN 60664-1 / up to 5,000 m above sea level)
Input data width (internal) max.	2 bits
Ambient temperature (operation)	-40 ... +70 °C
Dimensions W x H x D	(12 x 100 x 67.8) mm
Approvals	CE; Marine; OrdLoc/HazLoc; ATEX/IECEx
For data sheet and additional information, see:	wago.com/750-407/040-000

Notice: An additional supply module must be added for 220 VDC supply!

Digital output ► 24 VDC



750-508/040-000

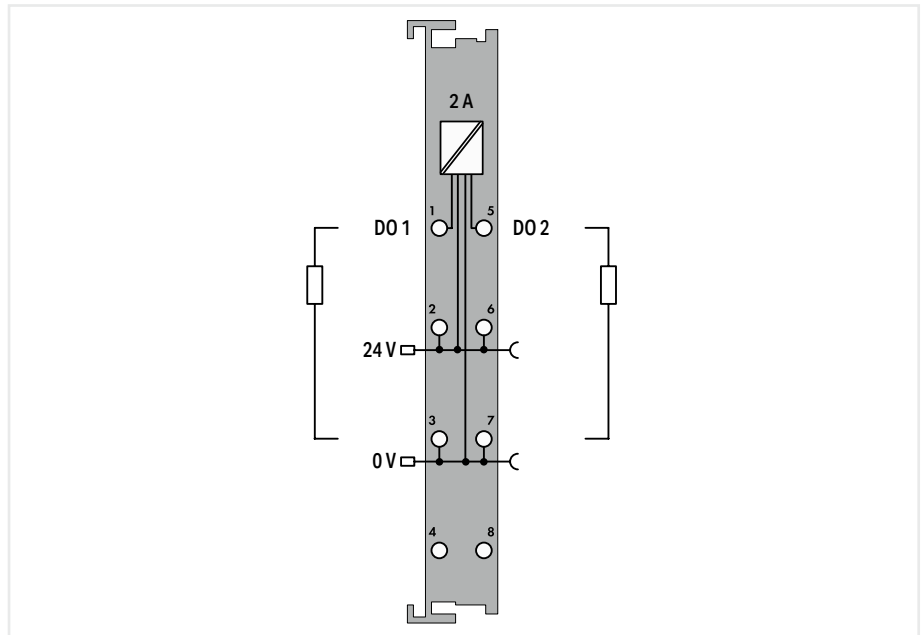

Item description	2-Channel Digital Output; 24 VDC; 2.0 A; Diagnostics
Version	extreme
Item no.	750-508/040-000
Order Text	2DO; 24 VDC; 2A; Diagn; XTR
Technical data	
Interference-free with safety function	Yes
Number of digital outputs	2
Signal type	Digital
Signal type (voltage)	24 VDC
Output characteristic	high-side switching
Output current per channel	2 A
Output current	short-circuit-protected
Load type	Resistive, inductive, lamp load
Actuator connection	2 x (2-wire, 3-wire)
Switching frequency (max.)	1 kHz
Diagnostics	Open circuit, short circuit, overload
Supply voltage (field)	24 VDC (-25 ... +30 %); via power jumper contacts (power supply via blade contact; transmission via spring contact); Derating must be observed!
Derating	Derating (supply voltage): Ambient temperatures under laboratory conditions: (-25 ... +30 %); for -40 ... +55 °C: 24 V (-25 ... +20 %); for +55 ... +70 °C: 24 V (-25 ... +10 %); Lower limit in all temperature ranges: -27.5 % (including 15 % residual ripple)
Current consumption, field supply (module with no external load)	7 mA
Current consumption (5 V system supply)	14 mA
Input data width (internal) max.	2 bits
Output data width (internal) max.	2 bits
Rated surge voltage	1 kV
Ambient temperature (operation)	-40 ... +70 °C
Dimensions W x H x D	(12 x 100 x 67.8) mm
Approvals	CE; Marine; OrdLoc/HazLoc; ATEX/IECEX
For data sheet and additional information, see:	wago.com/750-508/040-000

Digital output ► 24 VDC



750-537/040-000

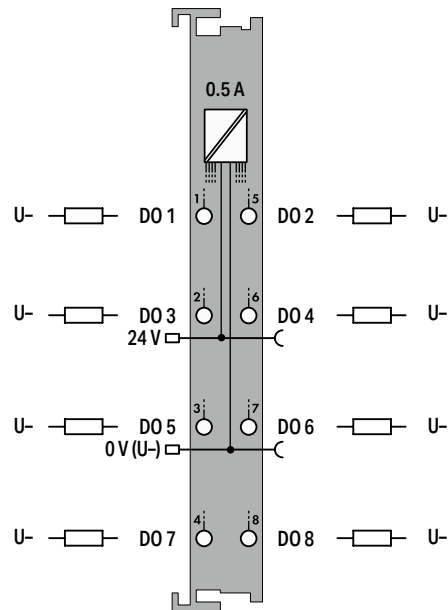

Item description	8-Channel Digital Output; 24 VDC; 0.5 A; Diagnostics
Version	extreme
Item no.	750-537/040-000
Order Text	8DO; 24 VDC; 0.5A; Diagn; XTR
Technical data	
Interference-free with safety function	Yes
Number of digital outputs	8
Signal type	Digital
Signal type (voltage)	24 VDC
Output characteristic	high-side switching
Output current per channel	0.5 A
Output current	short-circuit-protected
Load type	Resistive, inductive, lamp load
Actuator connection	8 x (1-wire)
Switching frequency (max.)	1 kHz
Diagnostics	Open circuit, short circuit, overload
Supply voltage (field)	24 VDC (-25 ... +30 %); via power jumper contacts (power supply via blade contact; transmission via spring contact); Derating must be observed!
Derating	Derating (supply voltage): Ambient temperatures under laboratory conditions: (-25 ... +30 %); for -40 ... +55 °C: 24 V (-25 ... +20 %); for +55 ... +70 °C: 24 V (-25 ... +10 %); Lower limit in all temperature ranges: -27.5 % (including 15 % residual ripple)
Current consumption, field supply (module with no external load)	16 mA
Current consumption (5 V system supply)	50 mA
Input data width (internal) max.	8 bits
Output data width (internal) max.	8 bits
Rated surge voltage	1 kV
Ambient temperature (operation)	-40 ... +70 °C
Dimensions W x H x D	(12 x 100 x 67.8) mm
Approvals	CE; Marine; OrdLoc/HazLoc; ATEX/IECEX
For data sheet and additional information, see:	wago.com/750-537/040-000

Digital output ▶ 24 VDC



750-1515/040-000

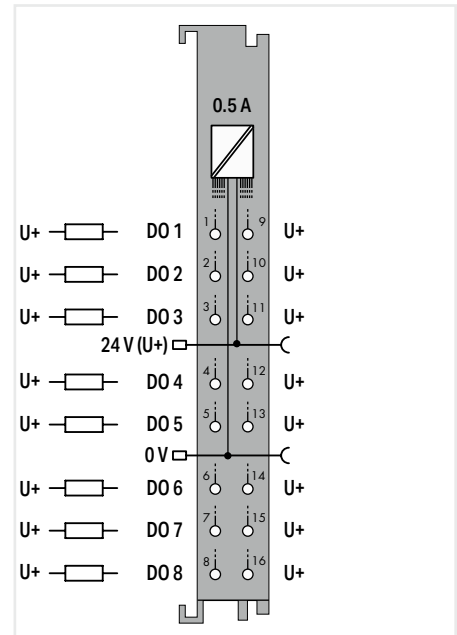
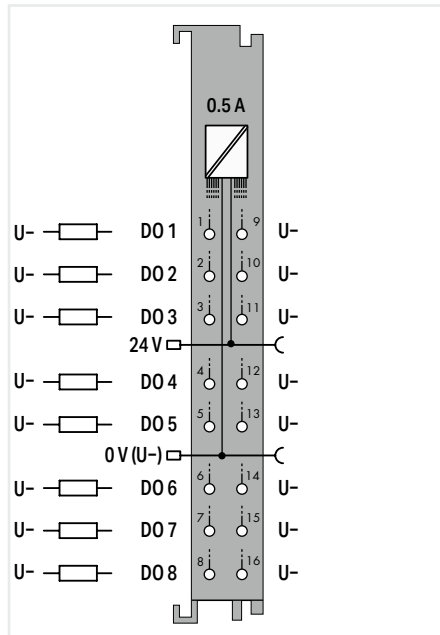

Item description
Version
Item no.
Order Text

8-Channel Digital Output; 24 VDC; 0.5 A; 2-wire connection
extreme with 16 connectors
750-1515/040-000
8DO; 24 VDC; 0.5A; 2-wire; XTR

8-Channel Digital Output; 24 VDC; 0.5 A; Low-Side Switching; 2-Wire Connection
extreme with 16 connectors
750-1516/040-000
8DO 24 VDC 0.5A LSS 2-wire XTR

Technical data
Interference-free with safety function
Number of digital outputs
Signal type
Signal type (voltage)
Output characteristic
Output current per channel
Output current
Load type
Actuator connection
Switching frequency (max.)
Supply voltage (field)

Yes
8
Digital
24 VDC
high-side switching
0.5 A
short-circuit-protected
Resistive, inductive, lamp load
8 x (2-wire)
1 kHz
24 VDC (-25 ... +30 %); via power jumper contacts (power supply via blade contact; transmission via spring contact); Derating must be observed!

-
8
Digital
24 VDC
low-side switching
0.5 A
short-circuit-protected
Resistive, inductive, lamp load
8 x (2-wire)
1 kHz
24 VDC (-25 ... +30 %); via power jumper contacts (power supply via blade contact; transmission via spring contact); Derating must be observed!

Derating
Current consumption, field supply (module with no external load)
Current consumption (5 V system supply)
Output data width (internal) max.
Rated surge voltage
Ambient temperature (operation)
Dimensions W x H x D
Approvals
For data sheet and additional information, see:

Derating (supply voltage): Ambient temperatures under laboratory conditions: (-25 ... +30 %); for -40 ... +55 °C: 24 V (-25 ... +20 %); for +55 ... +70 °C: 24 V (-25 ... +10 %); Lower limit in all temperature ranges: -27.5 % (including 15 % residual ripple)
15 mA
20 mA
8 bits
1 kV
-40 ... +70 °C
(12 x 100 x 69) mm
CE, Marine, OrdLoc/HazLoc, ATEX/IECEx
wago.com/750-1515/040-000

Derating (supply voltage): Ambient temperatures under laboratory conditions: (-25 ... +30 %); for -40 ... +55 °C: 24 V (-25 ... +20 %); for +55 ... +70 °C: 24 V (-25 ... +10 %); Lower limit in all temperature ranges: -27.5 % (including 15 % residual ripple)
8 mA
20 mA
8 bits
1 kV
-40 ... +70 °C
(12 x 100 x 69) mm
CE, Marine, OrdLoc/HazLoc
wago.com/750-1516/040-000

Digital output; Relay output ► Switching voltage: 250 VAC; 300 VDC



750-517/040-000

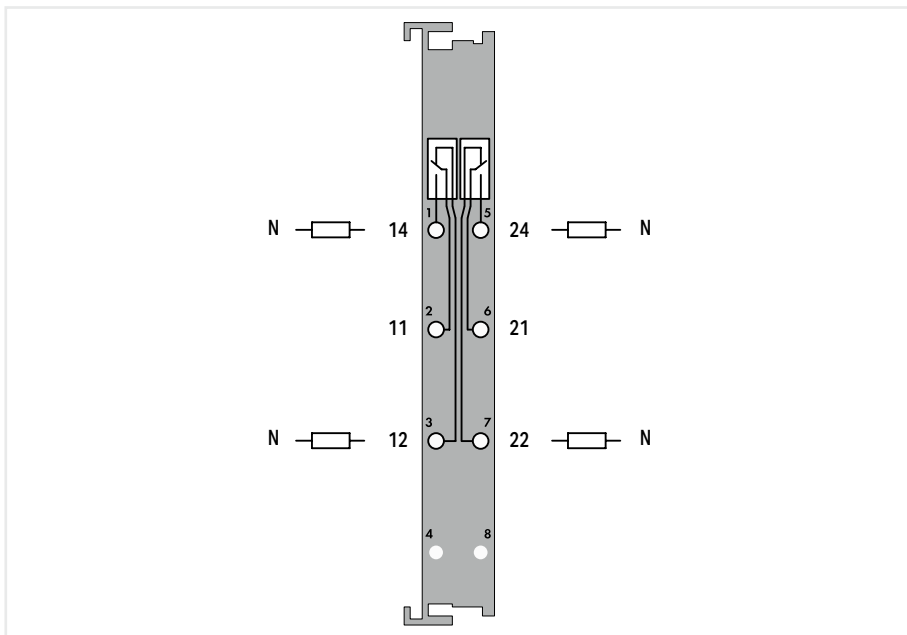

Item description	2-Channel Relay Output; 250 VAC; 1 A; Relay with 2 changeover contacts
Version	extreme
Item no.	750-517/040-000
Order Text	2RO; 250 VAC; 1A; Relay2CO; XTR
Technical data	
Number of digital outputs	2
Signal type	Digital
Switching voltage (max.)	250 VAC, 300 VDC
Output circuit design	2 changeover contacts; Relay
Output characteristic	potential-free
Switching current (max.)	1 A
Switching current (note)	1 A at 250 VAC and 40 VDC; 0.15 A at 300 VDC
Switching current (min.)	100 mA
Actuator connection	2 x (1-wire)
Switching frequency (max.)	0.1 Hz; Nominal load
Mechanical switching operations (min.) (at max. resistive load)	5 x 10 ⁶ switching operations
Electrical switching operations (min.) (at max. resistive load)	1 x 10 ⁶ switching operations
Current consumption (5 V system supply)	90 mA
Output data width (internal) max.	2 bits
Isolation, Field/System	per EN 61010-2-201: 3510 VAC/1 min
Rated surge voltage	5.0 kV (EN 60870-2-1 / Class VW3); 4.0 kV (UL 508); 6.4 kV (EN 61010-1)
Overvoltage category	Nominal voltage 230 V: III (EN 61010-1 / up to 2.000 m); II (EN 61010-1 / up to 5.000 m)
Ambient temperature (operation)	-40 ... +70 °C
Dimensions W x H x D	(12 x 100 x 67.8) mm
Approvals	CE; Marine; OrdLoc/HazLoc; ATEX/IECEx

For data sheet and additional information, see:

wago.com/750-517/040-000

Analog input ▶ 0 ... 20 mA ▶ Single-ended



750-453/040-000

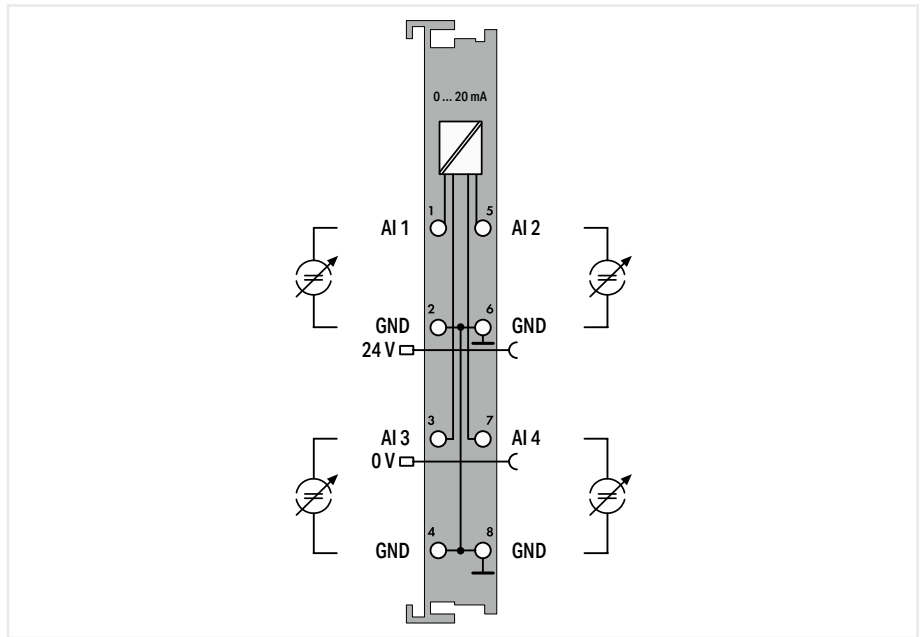

Item description	4-Channel Analog Input; 0 ... 20 mA; Single-ended
Version	extreme
Item no.	750-453/040-000
Order Text	4AI; 0-20mA; SE; XTR
Technical data	
Number of analog inputs	4
Signal type	Current
Signal type (current)	0 ... 20 mA/ADC
Signal characteristics	Single-ended
Sensor connection	4 x (2-wire)
Resolution [bit]	12 bits
Conversion time (typ.)	10 ms
Input resistance (max.)	100 Ω
Input voltage (max.)	32 V
Measurement error (reference temperature)	25 °C
Measurement error, deviation (max.) from the upper-range value	0.1 %
Temperature error (max.) of the upper-range value	0.01 %/K
Supply voltage (field)	24 VDC (-25 ... +30 %); via power jumper contacts (power supply via blade contact; transmission via spring contact); Derating must be observed!
Derating	
Derating (supply voltage): Ambient temperatures under laboratory conditions: (-25 ... +30 %); for -40 ... +55 °C: 24 V (-25 ... +20 %); for +55 ... +70 °C: 24 V (-25 ... +10 %); Lower limit in all temperature ranges: -27.5 % (including 15 % residual ripple)	
Current consumption (5 V system supply)	65 mA
Rated surge voltage	1 kV
Data width	4 x 16-bit data; 4 x 8-bit control/status (optional)
Ambient temperature (operation)	-40 ... +70 °C
Dimensions W x H x D	(12 x 100 x 67.8) mm
Approvals	CE; Marine; OrdLoc/HazLoc; ATEX/IECEX
For data sheet and additional information, see:	wago.com/750-453/040-000

Analog input ▶ 4 ... 20 mA ▶ Differential



750-492/040-001

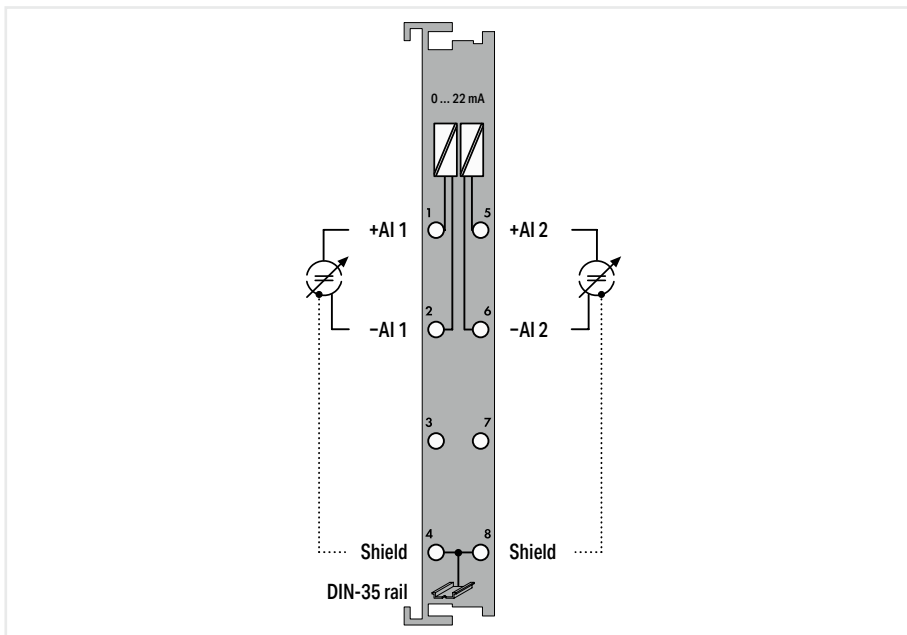

Item description	2-Channel Analog Input; 4 ... 20 mA; Differential input; NAMUR NE 43
Version	extreme
Item no.	750-492/040-001
Order Text	2AI; 4-20mA; Diff; NE43; XTR
Technical data	
Number of analog inputs	2
Signal type	Current
Signal type (current)	3.8 ... 20.5 mA DC
Signal characteristics	Differential
Sensor connection	2 x (2-wire)
Resolution [bit]	13 bits
Conversion time (typ.)	1 ms
Input resistance (max.)	270 Ω
Measurement error (reference temperature)	25 °C
Measurement error, deviation (max.) from the upper-range value	0.1 %
Temperature error (max.) of the upper-range value	0.01 %/K
Current consumption (5 V system supply)	80 mA
Rated surge voltage	1 kV
Data width	2 x 16-bit data; 2 x 8-bit control/status (optional)
Ambient temperature (operation)	-40 ... +70 °C
Dimensions W x H x D	(12 x 100 x 67.8) mm
Approvals	CE; Marine; OrdLoc/HazLoc; ATEX/IECEX
For data sheet and additional information, see:	wago.com/750-492/040-001

Sampling repetition time: 1 ms
 Sampling delay (module): ≤1 ms
 Sampling delay (channel/channel): ≤1 μs
 Sampling duration: ≤5 μs

Analog input ▶ 4 ... 20 mA ▶ Single-ended



750-455/040-000

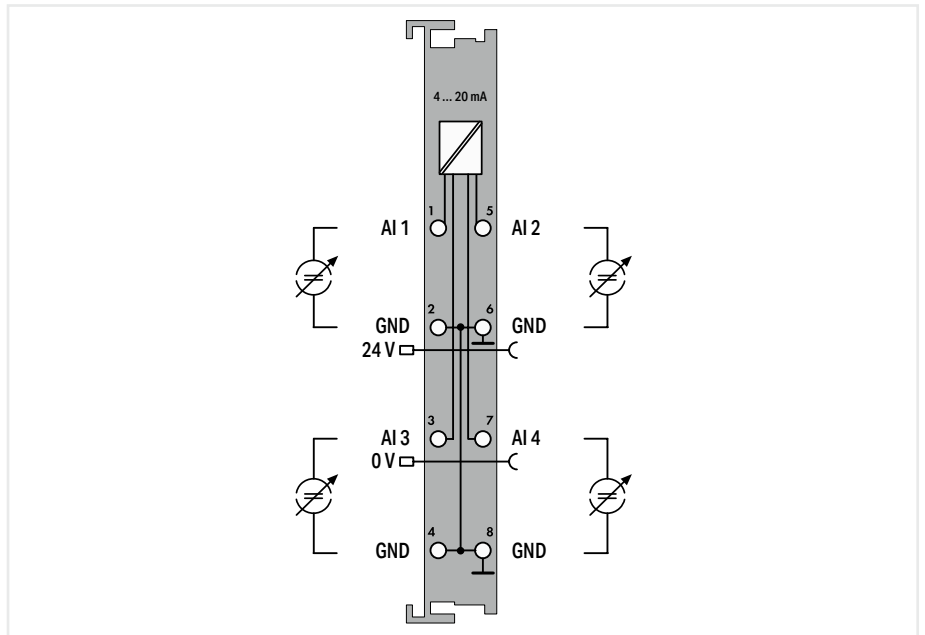

Item description	4-Channel Analog Input; 4 ... 20 mA; Single-ended
Version	extreme
Item no.	750-455/040-000
Order Text	4AI; 4-20mA; SE; XTR
Technical data	
Number of analog inputs	4
Signal type	Current
Signal type (current)	4 ... 20 mADC
Signal characteristics	Single-ended
Sensor connection	4 x (2-wire)
Resolution [bit]	12 bits
Conversion time (typ.)	10 ms
Input resistance (max.)	100 Ω
Input voltage (max.)	32 V
Measurement error (reference temperature)	25 °C
Measurement error, deviation (max.) from the upper-range value	0.1 %
Temperature error (max.) of the upper-range value	0.01 %/K
Supply voltage (field)	24 VDC (-25 ... +30 %); via power jumper contacts (power supply via blade contact; transmission via spring contact); Derating must be observed!
Derating	Derating (supply voltage): Ambient temperatures under laboratory conditions: (-25 ... +30 %); for -40 ... +55 °C: 24 V (-25 ... +20 %); for +55 ... +70 °C: 24 V (-25 ... +10 %); Lower limit in all temperature ranges: -27.5 % (including 15 % residual ripple)
Current consumption (5 V system supply)	65 mA
Rated surge voltage	1 kV
Data width	4 x 16-bit data; 4 x 8-bit control/status (optional)
Ambient temperature (operation)	-40 ... +70 °C
Dimensions W x H x D	(12 x 100 x 67.8) mm
Approvals	CE; Marine; OrdLoc/HazLoc; ATEX/IECEx
For data sheet and additional information, see:	wago.com/750-455/040-000

Analog input ▶ ±10 V ▶ Single-ended



750-457/040-000

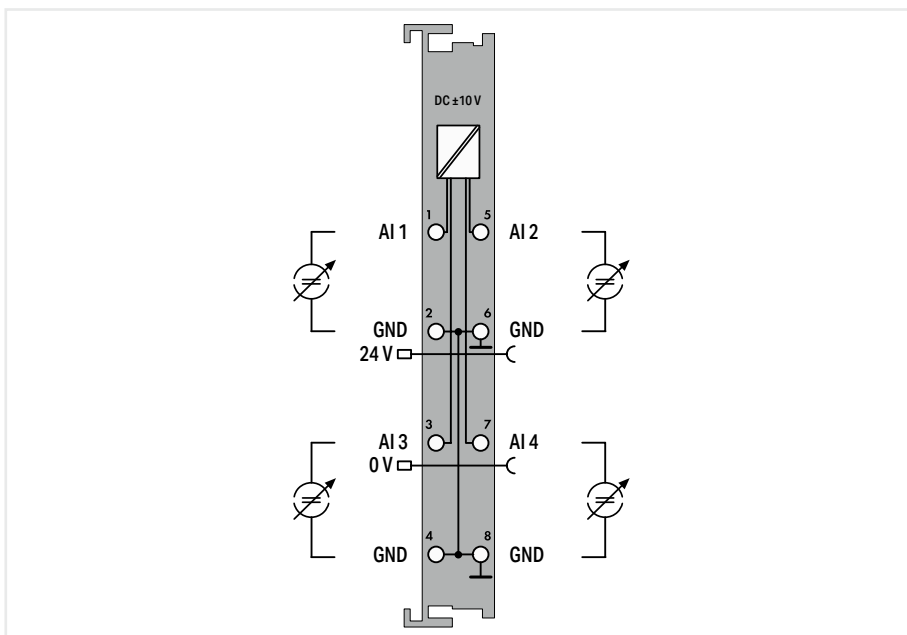

Item description	4-Channel Analog Input; ±10 VDC; Single-ended
Version	extreme
Item no.	750-457/040-000
Order Text	4AI; ±10 VDC; SE; XTR
Technical data	
Number of analog inputs	4
Signal type	Voltage
Signal type (voltage)	-10 ... +10 VDC
Signal characteristics	Single-ended
Sensor connection	4 x (2-wire)
Resolution [bit]	12 bits
Conversion time (typ.)	10 ms
Internal resistance	100 kΩ
Input voltage (max.)	±40 V
Measurement error (reference temperature)	25 °C
Measurement error, deviation (max.) from the upper-range value	0.1 %
Temperature error (max.) of the upper-range value	0.01 %/K
Supply voltage (field)	24 VDC (-25 ... +30 %); via power jumper contacts (power supply via blade contact; transmission via spring contact); Derating must be observed!
Derating	Derating (supply voltage): Ambient temperatures under laboratory conditions: (-25 ... +30 %); for -40 ... +55 °C: 24 V (-25 ... +20 %); for +55 ... +70 °C: 24 V (-25 ... +10 %); Lower limit in all temperature ranges: -27.5 % (including 15 % residual ripple)
Current consumption (5 V system supply)	65 mA
Rated surge voltage	1 kV
Data width	4 x 16-bit data; 4 x 8-bit control/status (optional)
Ambient temperature (operation)	-40 ... +70 °C
Dimensions W x H x D	(12 x 100 x 67.8) mm
Approvals	CE; Marine; OrdLoc/HazLoc; ATEX/IECEx
For data sheet and additional information, see:	wago.com/750-457/040-000

Analog input ▶ 0 ... 10 V ▶ Single-ended



750-468/040-000

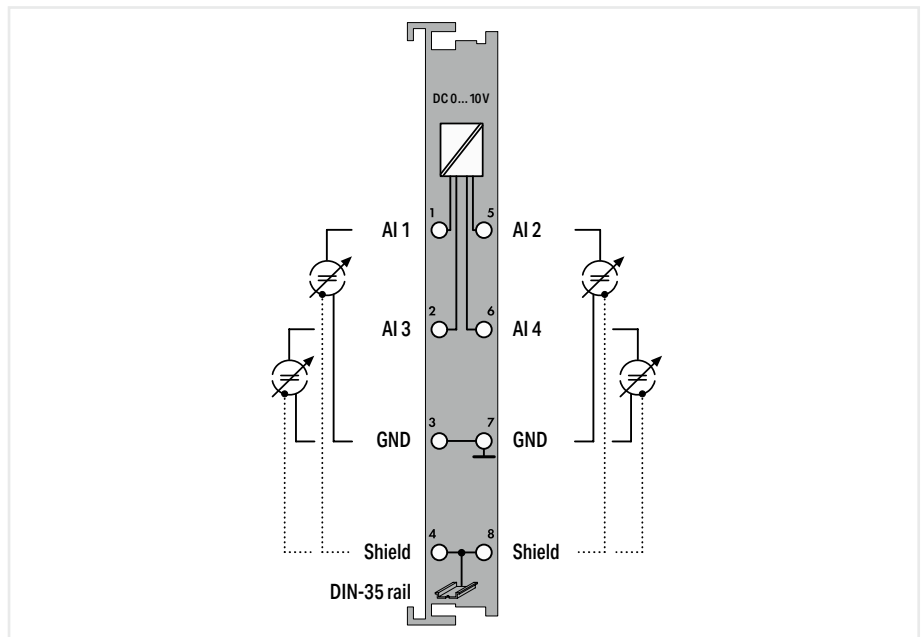

Item description	4-Channel Analog Input; 0 ... 10 VDC; single-ended
Version	extreme
Item no.	750-468/040-000
Order Text	4AI; 0-10 VDC; SE; XTR
Technical data	
Number of analog inputs	4
Signal type	Voltage
Signal type (voltage)	0 ... 10 VDC
Signal characteristics	Single-ended
Sensor connection	4 x (2-wire)
Resolution [bit]	12 bits
Conversion time (typ.)	4 ms
Internal resistance	133 kΩ
Input voltage (max.)	35 V
Measurement error (reference temperature)	25 °C
Measurement error, deviation (max.) from the upper-range value	0.2 %
Temperature error (max.) of the upper-range value	0.01 %/K
Current consumption (5 V system supply)	60 mA
Rated surge voltage	1 kV
Data width	4 x 16-bit data; 4 x 8-bit control/status (optional)
Ambient temperature (operation)	-40 ... +70 °C
Dimensions W x H x D	(12 x 100 x 67.8) mm
Approvals	CE; Marine; OrdLoc/HazLoc; ATEX/IECEX
For data sheet and additional information, see:	wago.com/750-468/040-000

Analog input ▶ 0 ... 30 V ▶ Differential



750-483/040-000

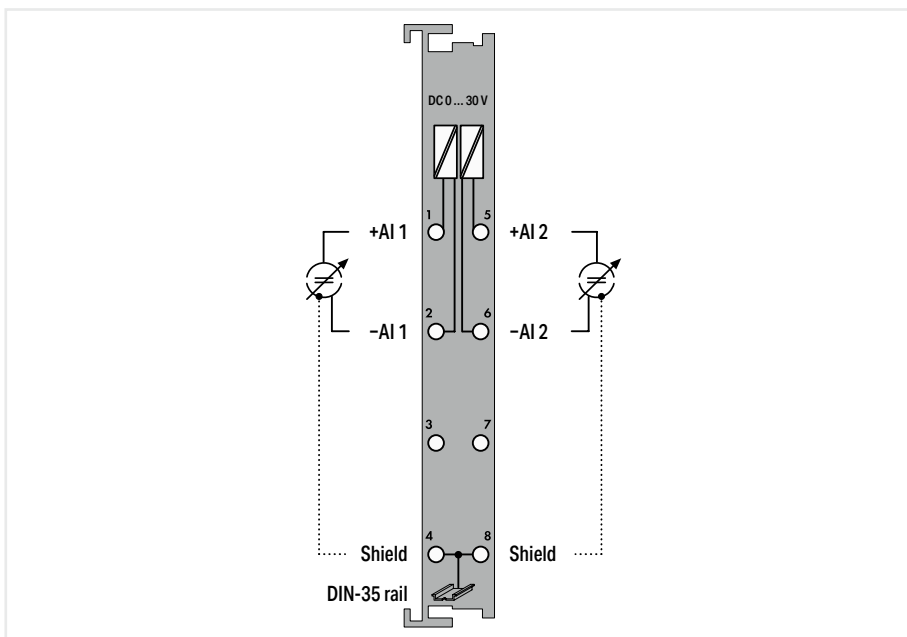

Item description	2-Channel Analog Input; 0 ... 30 VDC; Differential input
Version	extreme
Item no.	750-483/040-000
Order Text	2AI; 0-30 VDC; Diff; XTR
Technical data	
Extended functionality	Time-synchronized measured value acquisition within the module
Number of analog inputs	2
Signal type	Voltage
Signal type (voltage)	0 ... 30 VDC
Signal characteristics	Differential
Sensor connection	2 x (2-wire)
Resolution [bit]	14 bits
Conversion time (typ.)	1 ms
Internal resistance	1000 kΩ
Admissible continuous overload	60 V
Measurement error (reference temperature)	25 °C
Measurement error, deviation (max.) from the upper-range value	0.1 %
Temperature error (max.) of the upper-range value	0.01 %/K
Current consumption (5 V system supply)	80 mA
Rated surge voltage	1 kV
Data width	2 x 16-bit data; 2 x 8-bit control/status (optional)
Ambient temperature (operation)	-40 ... +70 °C
Dimensions W x H x D	(12 x 100 x 67.8) mm
Approvals	CE; Marine; OrdLoc/HazLoc; ATEX/IECEx
For data sheet and additional information, see:	wago.com/750-483/040-000

Analog input ► Voltages and currents (configurable channel for channel) ► Differential



750-471/040-000

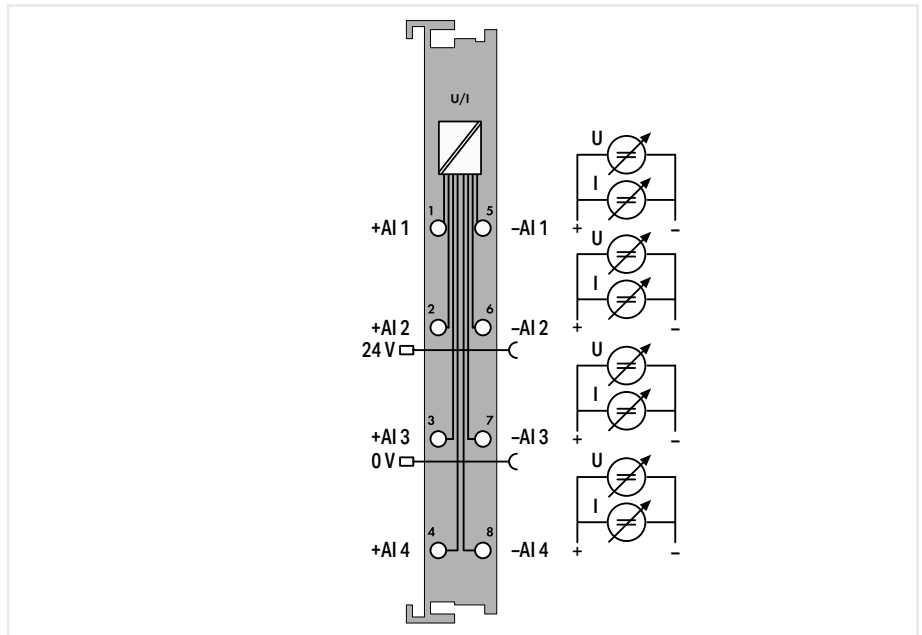

Item description	4-Channel Analog Input; for Voltage/Current
Version	extreme
Item no.	750-471/040-000
Order Text	4AI U/I Diff Galv XTR
Technical data	
Number of analog inputs	4
Signal type	Voltage; Current
Signal type (current)	0 ... 20 mADC; 4 ... 20 mADC; 3.6 ... 21 mADC; -20 ... +20 mADC
Signal type (voltage)	0 ... 10 VDC; -10 ... +10 VDC; -0.2 ... +0.2 VDC
Signal characteristics	Differential
Sensor connection	4 x (2-wire)
Resolution [bit]	16 bits
Conversion time (typ.)	10 ms
Input resistance (max.)	120 Ω
Internal resistance	100 kΩ
Input voltage (max.)	31.2 VDC
Reference for measurement error	Input ranges
Measurement error (reference temperature)	25 °C
Measurement error, deviation (max.) from the upper-range value	0.1 %
Reference for measurement error (2)	±200 mV
Measurement error, reference temperature (2)	25 °C
Measurement error, deviation (max.) of the upper-range value (2)	0.3 %
Temperature error (max.) of the upper-range value	0.01 %/K
Supply voltage (field)	24 VDC (-25 ... +30 %); via power jumper contacts (power supply via blade contact; transmission via spring contact); Derating must be observed!
Derating	Derating (supply voltage): Ambient temperatures under laboratory conditions: (-25 ... +30 %); for -40 ... +55 °C: 24 V (-25 ... +20 %); for +55 ... +70 °C: 24 V (-25 ... +10 %); Lower limit in all temperature ranges: -27.5 % (including 15 % residual ripple)
Current consumption (5 V system supply)	100 mA
Data width	4 x 16-bit data; 4 x 8-bit control/status (optional)
Isolation	Functional insulation: 2000 VDC system/channel; 2000 VDC channel/channel
Ambient temperature (operation)	-40 ... +70 °C
Dimensions W x H x D	(12 x 100 x 67.8) mm
Approvals	CE; Marine; OrdLoc/HazLoc
For data sheet and additional information, see:	wago.com/750-471/040-000

Analog input ► Resistance sensors



750-464/040-000

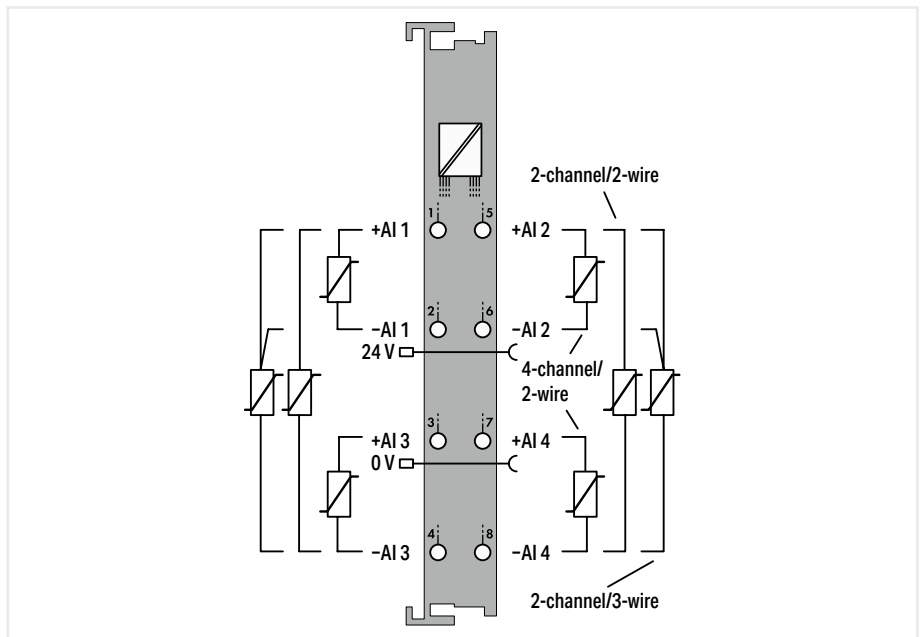

Item description	2/4-Channel Analog Input; Resistance measurement; Adjustable
Version	extreme
Item no.	750-464/040-000
Order Text	2/4AI; RTD; Adjust; XTR
Technical data	
Number of analog inputs	4
Signal type	Resistance measurement; Potentiometer positions
Sensor types	Pt100; Configurable: Pt200, Pt500, Pt1000 (IEC 751), Ni100, Ni1000 (DIN 43760), Ni120 (Minco), Ni1000 (TK 5000), Potentiometer (2-channel operation only): 10R ... 1k Ω , 10R ... 5k Ω
Sensor connection	4 x (2-wire); 2 x (3-wire)
Temperature range	-200 ... +850 °C (Pt), -60 ... +300 °C (Ni 100, Ni 1000), -60 ... +250 °C (Ni 1000 TK5000), -80 ... +260 °C (Ni 120)
Resolution (over entire range)	0.1 °C
Conversion time (typ.)	320 ms
Measuring current (typ.)	$\leq 350 \mu\text{A}$ per measurement circuit
Measurement error (25 °C)	$\leq 1 \text{ K}$ over entire temperature range, $\leq 0.5 \text{ K}$ over limited temperature range (-30 °C ... +120 °C)
Temperature coefficient	$\leq 20 \text{ ppm/K}$; typ. $\leq 15 \text{ ppm/K}$
Supply voltage (field)	24 VDC (-25 ... +30 %); via power jumper contacts (power supply via blade contact; transmission via spring contact); Derating must be observed!
Derating	Derating (supply voltage): Ambient temperatures under laboratory conditions: (-25 ... +30 %); for -40 ... +55 °C: 24 V (-25 ... +20 %); for +55 ... +70 °C: 24 V (-25 ... +10 %); Lower limit in all temperature ranges: -27.5 % (including 15 % residual ripple)
Current consumption (5 V system supply)	50 mA
Rated surge voltage	1 kV
Data width	4 (2) x 16-bit data; 4 (2) x 8-bit control/status (optional)
Ambient temperature (operation)	-40 ... +70 °C
Dimensions W x H x D	(12 x 100 x 67.8) mm
Approvals	CE; Marine; OrdLoc/HazLoc; ATEX/IECEX

For data sheet and additional information, see:

wago.com/750-464/040-000

Analog input ▶ Thermocouples



750-469/040-000

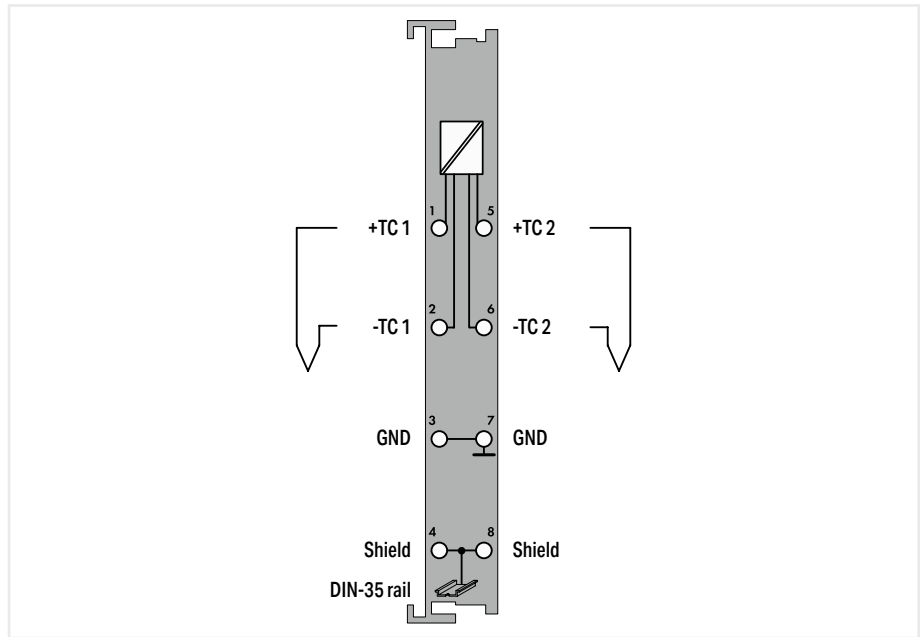

Item description
Version
Item no.
Order Text

2-Channel Analog Input; Thermocouple; Adjustable
extreme
750-469/040-000
2AI; TC; Adjust; XTR

Technical data
Number of analog inputs
Signal type
Sensor types
Sensor connection
Temperature range
Resolution (over entire range)
Conversion time (typ.)
Internal resistance
Measurement error (25 °C)
Temperature coefficient
Cold junction compensation
Current consumption (5 V system supply)
Rated surge voltage
Data width
Ambient temperature (operation)
Dimensions W x H x D
Approvals
For data sheet and additional information, see:

2
Thermocouple; Low voltages
Thermocouple K; Configurable: J, E, S, T, L, N, U, B, R; ±30 mV, ±60 mV, ±120 mV
2 x (2-wire)
Sensor-specific
0.1 °C
320 ms
1000 kΩ
< ±6 K (voltage input < ±2 K; cold junction compensation < ±4 K)
< ±0.2 K/K
at each pair of terminal blocks
65 mA
1 kV
2 x 16-bit data; 2 x 8-bit control/status (optional)
-40 ... +70 °C
(12 x 100 x 67.8) mm
CE; Marine; OrdLoc/HazLoc; ATEX/IECEX
wago.com/750-469/040-000

8

Analog input; Power measurement ► Three-phase power measurement



750-495/040-010

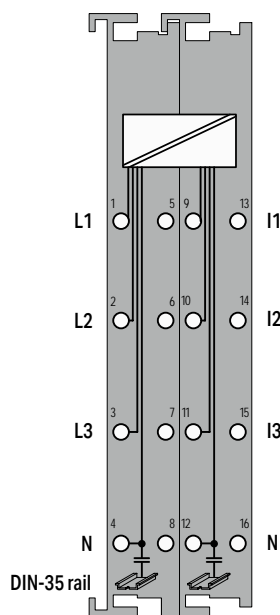

Item description	3-Phase Power Measurement; 20 kVAC 300 A
Version	20 kVAC; 300 A; extreme
Item no.	750-495/040-010
Order Text	3-PHASE POM; 20KV; 300A; XTR
Technical data	
Signal type	Power measurement
Calculated values	Line-to-line voltage, power output, energy, power factors, mains frequency, harmonic analysis (up to the 41st harmonic), THD
Number of measurement inputs	6 (3 input pairs for voltage and current measurement sensors)
Input voltage (max.)	with sensor: 20 kV / $\sqrt{3}$ (Module input: 3.25 V / $\sqrt{3}$)
Input current (max.)	with sensor: 300 A AC; (Module input: 225 mV)
Voltage path input resistance (typ.)	200.3 k Ω
Current path input resistance (typ.)	20.8 Ω
Resolution [bit]	24 bits
Measurement method	True RMS measurement
Reference for measurement error	AC current/voltage
Measurement error, deviation (max.) from the upper-range value	0.3 %
Frequency range (mains frequency)	45 ... 65 Hz
Frequency range (harmonics analysis)	45 ... 2665 Hz
Limit frequency	8.6 kHz
Signal form	Any periodic signals (considering the threshold frequencies)
Current consumption (5 V system supply)	100 mA
Rated surge voltage	4 kV
Overvoltage category	III (EN 61010)
Data width	2 x 128-bit data; 2 x 64-bit control/status
Ambient temperature (operation)	-40 ... +70 °C
Dimensions W x H x D	(24 x 100 x 67.8) mm
Approvals	CE
For data sheet and additional information, see:	wago.com/750-495/040-010

Analog input; Power measurement ▶ Three-phase power measurement



750-495/040-000

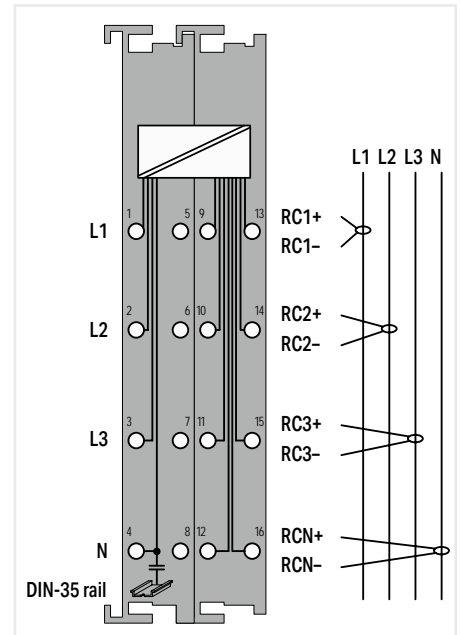
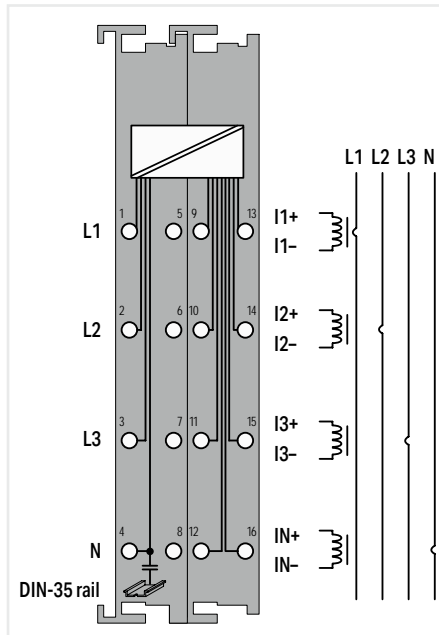

Item description
Version
Item no.
Order Text

3-Phase Power Measurement; 690 VAC 1 A	
extreme	690 VAC 5 A; extreme
750-495/040-000	750-495/040-001
3-PHASE POM; 690VAC 1A; XTR	3-PHASE POM; 690VAC 5A; XTR

3-Phase Power Measurement; 690 VAC Rogowski coils	
690 VAC Rogowski coils; extreme	
750-495/040-002	
3-PHASE POM; 690VAC R.C.; XTR	

Technical data
Signal type
Calculated values
Number of measurement inputs
Rated voltage
Voltage path input resistance (typ.)
Measurement current (max.)
Current path input resistance (typ.)
Resolution [bit]
Measurement method
Reference for measurement error
Measurement error (reference temperature)
Measurement error, deviation (max.) from the upper-range value
Frequency range (mains frequency)
Frequency range (harmonics analysis)
Limit frequency
Signal form
Current consumption (5 V system supply)
Rated surge voltage
Oversvoltage category
Data width
Ambient temperature (operation)
Dimensions W x H x D
Approvals
For data sheet and additional information, see:

Power measurement
Line-to-line voltage, power output, energy, power factors, mains frequency, harmonic analysis (up to the 41st harmonic), THD
7 (3 voltage measurement inputs, 4 differential current measurement inputs)
$U_{LN} = 400 \text{ VAC}; U_{LL} = 690 \text{ VAC}$
1429 k Ω
1 A 5 A
0.022 Ω 0.005 Ω
24 bits
True RMS measurement
AC current/voltage
25 $^{\circ}\text{C}$
0.5 %
45 ... 65 Hz
0 ... 3300 Hz
15.9 kHz
Any periodic signals (considering the threshold frequencies)
100 mA
5.0 kV (EN 60870-2-1 / Class VW3); 6.0 kV (UL 508); 6.0 kV (EN 60664-1 / to 4,000 m ASL); 4.0 kV (EN 60664-1 / > 4,000 m to 5,000 m ASL)
Nominal voltage 400 V/690 V in a 3-phase system: III (EN 60664-1 / to 4,000 m ASL); II (EN 60664-1 / > 4,000 m up to 5,000 m ASL)
2 x 128-bit data; 2 x 64-bit control/status
-40 ... +70 $^{\circ}\text{C}$
(24 x 100 x 67.8) mm
CE; Marine; ATEX/IECEx
wago.com/750-495/040-000

Power measurement
Line-to-line voltage, power output, energy, power factors, mains frequency, harmonic analysis (up to the 41st harmonic), THD
7 (3 voltage measurement inputs, 4 differential current measurement inputs)
$U_{LN} = 400 \text{ VAC}; U_{LL} = 690 \text{ VAC}$
1429 k Ω
Rogowski coils RT500/RT2000
44000 Ω
24 bits
True RMS measurement
AC current/voltage
25 $^{\circ}\text{C}$
0.5 %
45 ... 65 Hz
0 ... 3300 Hz
15.9 kHz
Any periodic signals (considering the threshold frequencies)
100 mA
5.0 kV (EN 60870-2-1 / Class VW3); 6.0 kV (UL 508); 6.0 kV (EN 60664-1 / to 4,000 m ASL); 4.0 kV (EN 60664-1 / > 4,000 m to 5,000 m ASL)
Nominal voltage 400 V/690 V in a 3-phase system: III (EN 60664-1 / to 4,000 m ASL); II (EN 60664-1 / > 4,000 m up to 5,000 m ASL)
2 x 128-bit data; 2 x 64-bit control/status
-40 ... +70 $^{\circ}\text{C}$
(24 x 100 x 67.8) mm
CE; Marine; ATEX/IECEx
wago.com/750-495/040-000

Analog output ► Configurable: current/voltage



750-563/040-000

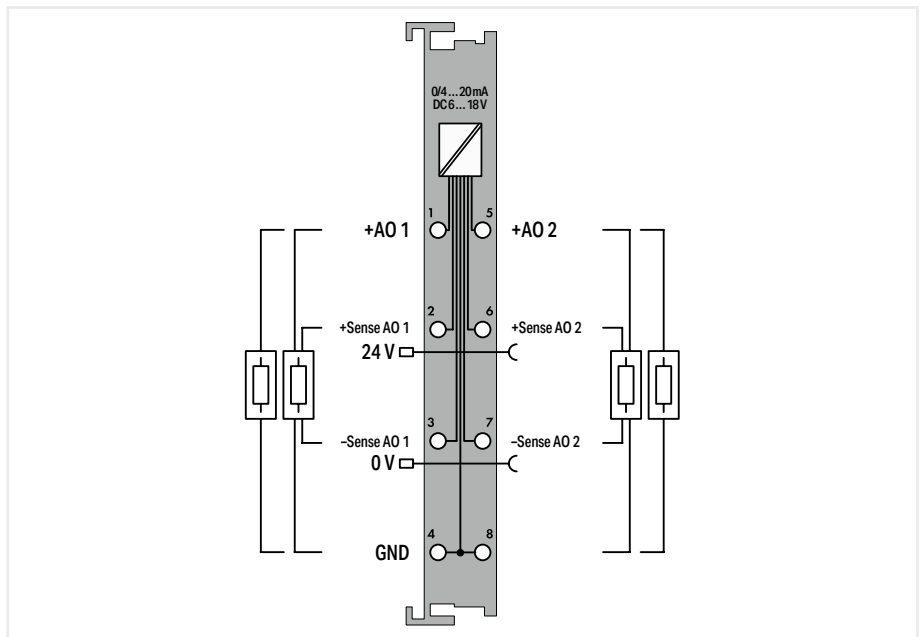

Item description	2-Channel Analog Output; 0/4 ... 20 mA; 16 bits; 6 ... 18 VDC
Version	extreme
Item no.	750-563/040-000
Order Text	2AO; 0/4-20mA; 16bits; 6-18 VDC; XTR
Technical data	
Number of analog outputs	2
Signal type	Voltage; Current
Signal type (current)	0 ... 20 mADC; 4 ... 20 mADC
Signal type (voltage)	6 ... 18 VDC
Actuator connection	2 x (2-wire, 4-wire)
Load impedance (current output)	≤ 500 Ω
Load impedance (voltage output)	≥ 1.8 kΩ
Resolution [bit]	16 bits
Conversion time (typ.)	5 ms
Output error, reference temperature	25 °C
Output error, deviation (max.) of the upper-range value	0.05 %
Temperature coefficient	< ±100 ppm
Supply voltage (field)	24 VDC (-15 ... +30 %); via power jumper contacts (power supply via blade contact; transmission via spring contact); Derating must be observed!
Derating	Derating (supply voltage): Ambient temperatures under laboratory conditions: (-25 ... +30 %); for -40 ... +55 °C: 24 V (min. ... +20 %); for +55 ... +70 °C: 24 V (min. ... +10 %); Voltage range (min.): 21.6 V; Current range (min.): 20.4 V; Lower limit in all temperature ranges: -27.5 % (including 15 % residual ripple)
Current consumption (5 V system supply)	95 mA
Rated surge voltage	1 kV
Data width	2 x 16-bit data; 2 x 8-bit control/status (optional)
Ambient temperature (operation)	-40 ... +70 °C
Dimensions W x H x D	(12 x 100 x 67.8) mm
Approvals	CE; Marine; OrdLoc/HazLoc; ATEX/IECEX

For data sheet and additional information, see:

wago.com/750-563/040-000

Analog output ► ± 10 V

750-557/040-000

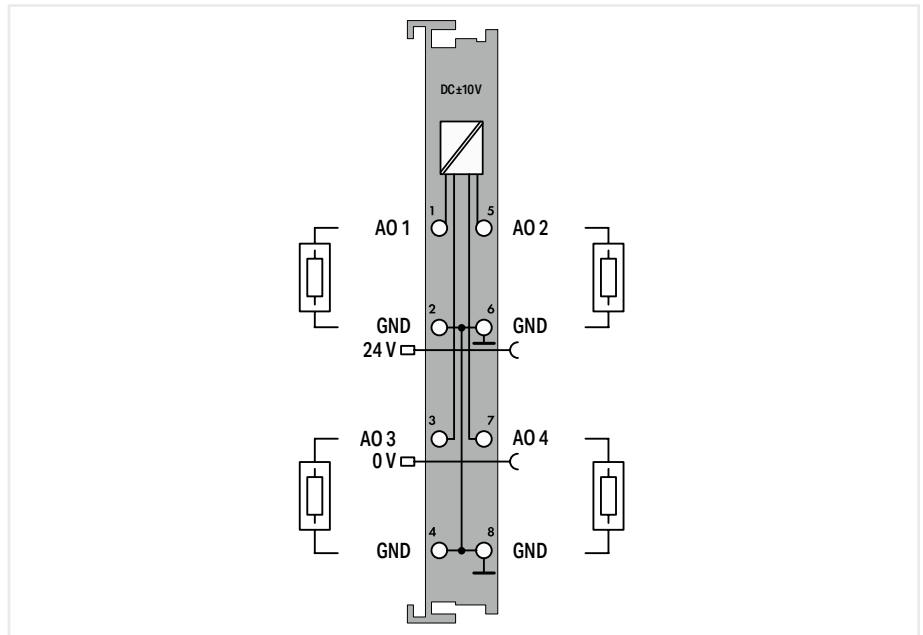

Item description	4-Channel Analog Output; ± 10 VDC
Version	extreme
Item no.	750-557/040-000
Order Text	4AO; ± 10 VDC; XTR
Technical data	
Number of analog outputs	4
Signal type	Voltage
Signal type (voltage)	-10 ... +10 VDC
Actuator connection	4 x (2-wire)
Load impedance (voltage output)	≥ 5 k Ω
Resolution [bit]	12 bits
Conversion time (typ.)	10 ms
Output error, reference temperature	25 °C
Output error, deviation (max.) of the upper-range value	0.1 %
Temperature error (max.) of the output range value	0.01 %/K
Supply voltage (field)	24 VDC (-25 ... +30 %); via power jumper contacts (power supply via blade contact; transmission via spring contact); Derating must be observed!
Derating	Derating (supply voltage): Ambient temperatures under laboratory conditions: (-25 ... +30 %); for -40 ... +55 °C: 24 V (-25 ... +20 %); for +55 ... +70 °C: 24 V (-25 ... +10 %); Lower limit in all temperature ranges: -27.5 % (including 15 % residual ripple)
Current consumption (5 V system supply)	125 mA
Rated surge voltage	1 kV
Data width	4 x 16-bit data; 4 x 8-bit control/status (optional)
Ambient temperature (operation)	-40 ... +70 °C
Dimensions W x H x D	(12 x 100 x 67.8) mm
Approvals	CE; Marine; OrdLoc/HazLoc; ATEX/IECEx
For data sheet and additional information, see:	wago.com/750-557/040-000

Analog output ► 0 ... 10 V



750-559/040-000

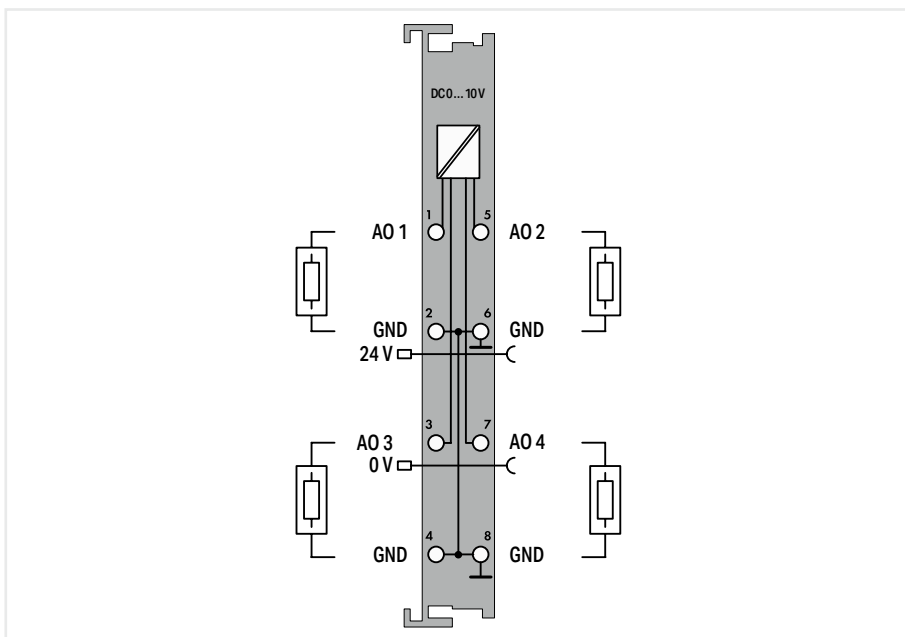

Item description	4-Channel Analog Output; 0 ... 10 VDC
Version	extreme
Item no.	750-559/040-000
Order Text	4AO; 0-10 VDC; XTR
Technical data	
Number of analog outputs	4
Signal type	Voltage
Signal type (voltage)	0 ... 10 VDC
Actuator connection	4 x (2-wire)
Load impedance (voltage output)	≥ 5 kΩ
Resolution [bit]	12 bits
Conversion time (typ.)	10 ms
Output error, reference temperature	25 °C
Output error, deviation (max.) of the upper-range value	0.1 %
Temperature error (max.) of the output range value	0.01 %/K
Supply voltage (field)	24 VDC (-25 ... +30 %); via power jumper contacts (power supply via blade contact; transmission via spring contact); Derating must be observed!
Derating	Derating (supply voltage): Ambient temperatures under laboratory conditions: (-25 ... +30 %); for -40 ... +55 °C: 24 V (-25 ... +20 %); for +55 ... +70 °C: 24 V (-25 ... +10 %); Lower limit in all temperature ranges: -27.5 % (including 15 % residual ripple)
Current consumption (5 V system supply)	125 mA
Rated surge voltage	1 kV
Data width	4 x 16-bit data; 4 x 8-bit control/status (optional)
Ambient temperature (operation)	-40 ... +70 °C
Dimensions W x H x D	(12 x 100 x 67.8) mm
Approvals	CE; Marine; OrdLoc/HazLoc; ATEX/IECEX
For data sheet and additional information, see:	wago.com/750-559/040-000

Counter



750-404/040-003

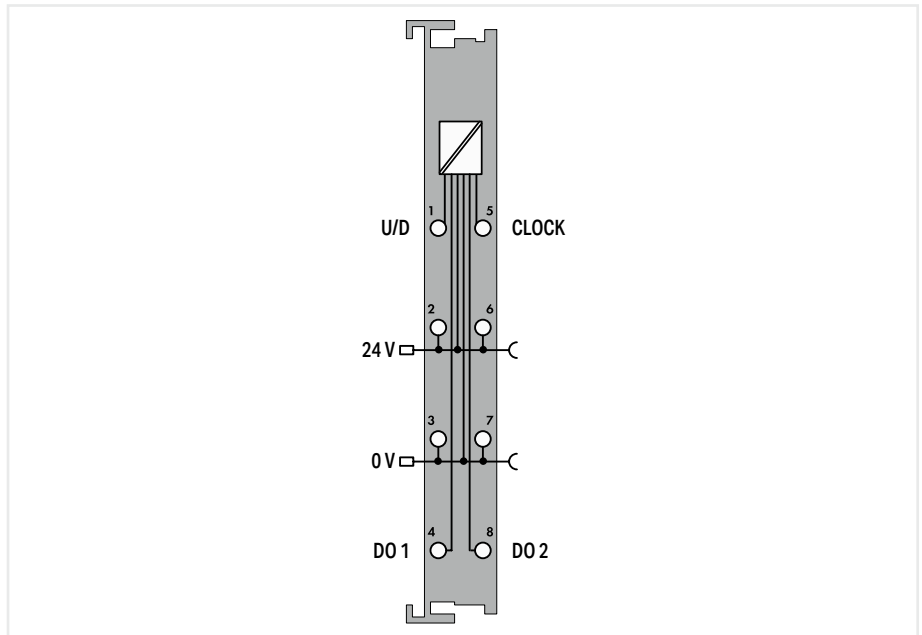

Item description
Version
Item no.
Order Text

Counter; adjustable
extreme
750-404/040-003
Counter; Adjust; XTR

Technical data
Number of digital outputs
Number of counters
Output current per channel
Output current
Voltage range for signal (0)
Voltage range for signal (1)
Input current (typ.)
Switching frequency (max.)
Counter depth
Supply voltage (field)
Derating
Current consumption (5 V system supply)
Rated surge voltage
Data width
Operating mode
Ambient temperature (operation)
Dimensions W x H x D
Approvals

2
1
0.5 A
short-circuit-protected
-3 ... +5 VDC
15 ... 30 VDC
7 mA
100 kHz
32 bits
24 VDC (-25 ... +30 %); via power jumper contacts (power supply via blade contact; transmission via spring contact); Derating must be observed!
Derating (supply voltage): Ambient temperatures under laboratory conditions: (-25 ... +30 %); for -40 ... +55 °C: 24 V (-25 ... +20 %); for +55 ... +70 °C: 24 V (-25 ... +10 %); Lower limit in all temperature ranges: -27.5 % (including 15 % residual ripple)
70 mA
1 kV
32-bit data; 8-bit control/status
Up/down counter/100 kHz; Up counter/enable input; Peak-time counter; Frequency measurement: 0.1 Hz ... 100 kHz (default setting); Up/down counter/signal outputs (DO); Two up counters/16 bits/5 kHz
-40 ... +70 °C
(12 x 100 x 67.8) mm
CE; Marine; OrdLoc/HazLoc; ATEX/IECEX

For data sheet and additional information, see:

wago.com/750-404/040-003

Pulse width modulation



750-677/040-000

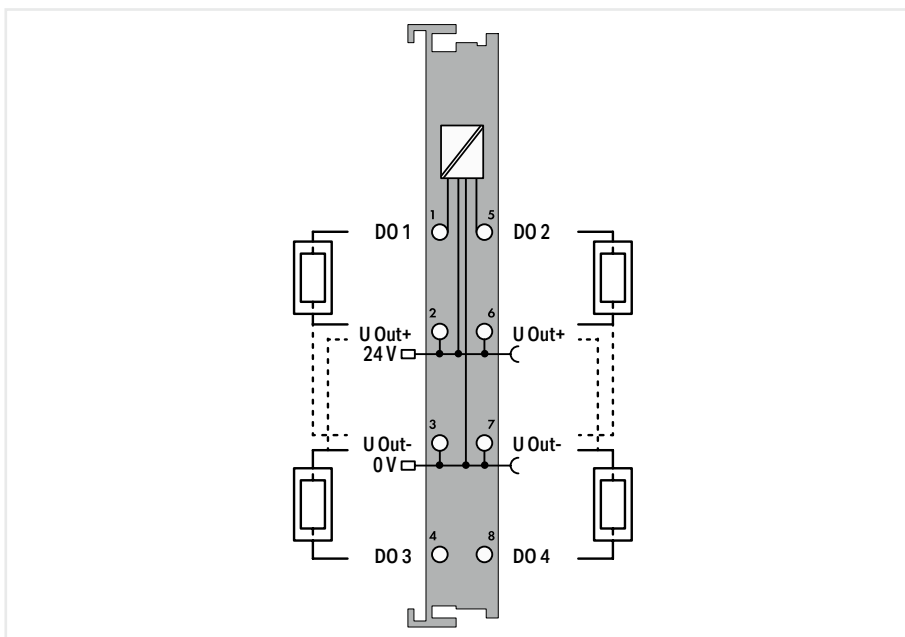

Item description	4-Channel Pulse Width Outputs; 24 VDC; 0.2 A; 20 kHz
Version	extreme
Item no.	750-677/040-000
Order Text	4PWM; 24 VDC; 0.2A; 20kHz; XTR
Technical data	
Number of digital outputs	4
Pulse frequency	0 ... 20,000 Hz; integer
Duty cycle	0 ... 100 %; 11-bit resolution
Output current per channel	0.2 A
Output current	short-circuit-protected; 0.4 A, short-circuit-protected in bridge mode
Switching frequency (max.)	20 kHz
Supply voltage (field)	24 VDC (-25 ... +30 %); via power jumper contacts (power supply via blade contact; transmission via spring contact); Derating must be observed!
Derating	Derating (supply voltage): Ambient temperatures under laboratory conditions: (-25 ... +30 %); for -40 ... +55 °C: 24 V (-25 ... +20 %); for +55 ... +70 °C: 24 V (-25 ... +10 %); Lower limit in all temperature ranges: -27.5 % (including 15 % residual ripple)
Current consumption (5 V system supply)	85 mA
Rated surge voltage	1 kV
Data width	4 x 16-bit data; 4 x 8-bit control/status
Operating mode	1: PWM DC (variable duty cycle); 2: PWM Frq (variable frequency); 3: PWM Frq - Cnt; 4: Pulse Frq - Cnt; 5: PWM Pulse - Dir
Ambient temperature (operation)	-40 ... +70 °C
Dimensions W x H x D	(12 x 100 x 67.8) mm
Approvals	CE
Approvals (pending)	Marine; OrdLoc/HazLoc
For data sheet and additional information, see:	wago.com/750-677/040-000

This module outputs separately adjustable PWM signals at four channels. The channels can be individually configured as LSS (low-side switching) or HSS (high-side switching) and are short-circuit protected. The PWM signals are each 16 bits wide.

The module supports five operating modes. In both "PWM DC" and "PWM Frq" operating modes, all four channels may be used independently. The bridge mode can also be activated if the same operating mode is set on each channel pair (1 and 2 or 3 and 4). Both channels work synchronously and can be connected in parallel. In the other three complex operating modes, two channels functionally correlate with each other.

The first channel outputs the PWM signal and the second channel a static signal ("0" or "1").

Refer to the manual ("Operating Modes" section) for all setting options and the bit signification in the process image. The "PWM DC" operating mode is set by default.

Distance and angle measurement



750-637/040-001

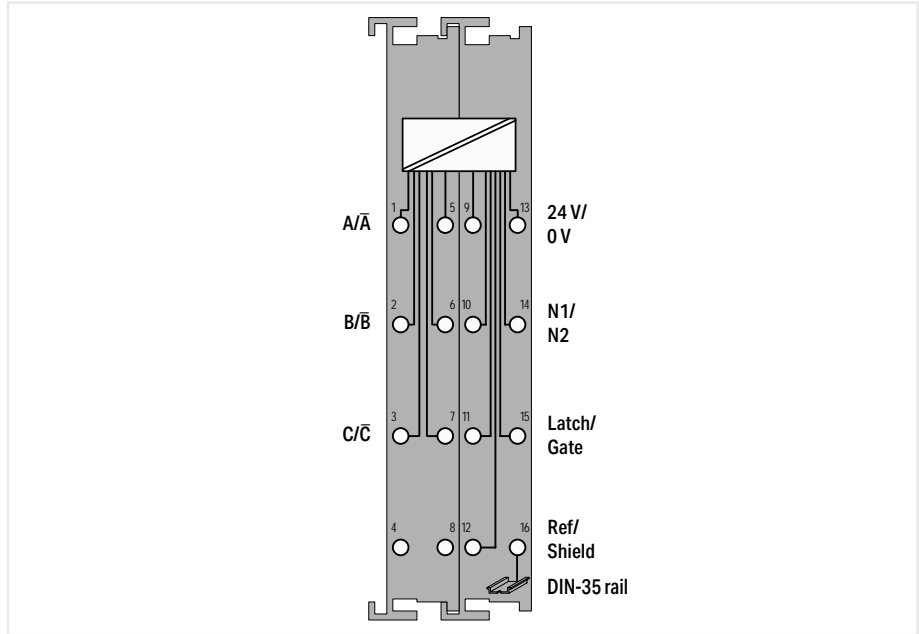

Item description	Incremental Encoder Interface; 24 VDC; Differential input; 32 bits
Version	extreme
Item no.	750-637/040-001
Order Text	Inc. Encoder; 24 VDC; Diff; 32bits; XTR

Technical data	
Encoder connection	A, A/, B, B/, C, C/
Counter depth	32 bits
Limit frequency	250 kHz
Quadrature decoder	4x evaluation
Zero impulse (latch)	32 bits
Commands	Reading, setting, activating
Supply voltage (encoder)	24 VDC
Output voltage	24 VDC
Output current per channel	0.5 A
Output current	short-circuit-protected
Voltage range for signal (0)	($U_{ABC} - U_{ABC}$): -30 ... +15 VDC; Latch, gate, ref.: -3 ... +5 VDC
Voltage range for signal (1)	($U_{ABC} - U_{ABC}$): 15 ... 30 VDC; Latch, gate, ref.: 15 ... 30 VDC
Input current (typ.)	Latch 7 mA, Gate 7 mA, Ref. 7 mA
Current consumption, field supply (module with no external load)	35 mA
Current consumption (5 V system supply)	110 mA
Rated surge voltage	1 kV
Data width	1 x 32-bit data 2 x 8-bit control/status
Ambient temperature (operation)	-40 ... +70 °C
Dimensions W x H x D	(24 x 100 x 67.8) mm
Approvals	CE; Marine; OrdLoc/HazLoc; ATEX/IECEX

For data sheet and additional information, see:

wago.com/750-637/040-001

Distance and angle measurement



750-637/040-000

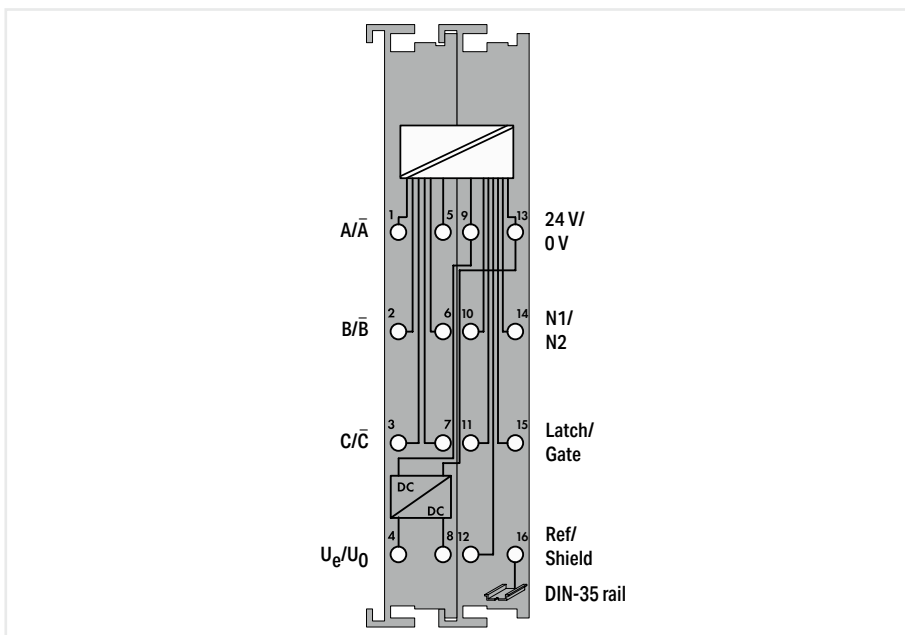

Item description

Version

Item no.

Order Text

Incremental Encoder Interface; RS-422; 32 Bits

extreme

750-637/040-000

Inc. Encoder; RS422; 32Bit; XTR

Technical data

Encoder connection	A; /A; B; /B; C; /C (RS-422 inputs)
Counter depth	32 bits
Limit frequency	250 kHz
Quadrature decoder	4x evaluation
Zero impulse (latch)	32 bits
Commands	Reading, setting, activating
Supply voltage (encoder)	5 VDC
Output voltage	24 VDC
Output current per channel	0.5 A
Output current	short-circuit-protected
Voltage range for signal (0)	$U_{ABC} = \text{RS-422; Latch, gate, ref.: } -3 \dots +5 \text{ VDC}$
Voltage range for signal (1)	$U_{ABC} = \text{RS-422; Latch, gate, ref.: } 15 \dots 30 \text{ VDC}$
Input current (typ.)	Latch 7 mA, Gate 7 mA, Ref. 7 mA
Current consumption, field supply (module with no external load)	35 mA
Current consumption (5 V system supply)	110 mA
Rated surge voltage	1 kV
Data width	1 x 32-bit data 2 x 8-bit control/status
Ambient temperature (operation)	-40 ... +70 °C
Dimensions W x H x D	(24 x 100 x 67.8) mm
Approvals	CE; Marine; OrdLoc/HazLoc

For data sheet and additional information, see:

wago.com/750-637/040-000

Distance and angle measurement



750-630/040-001

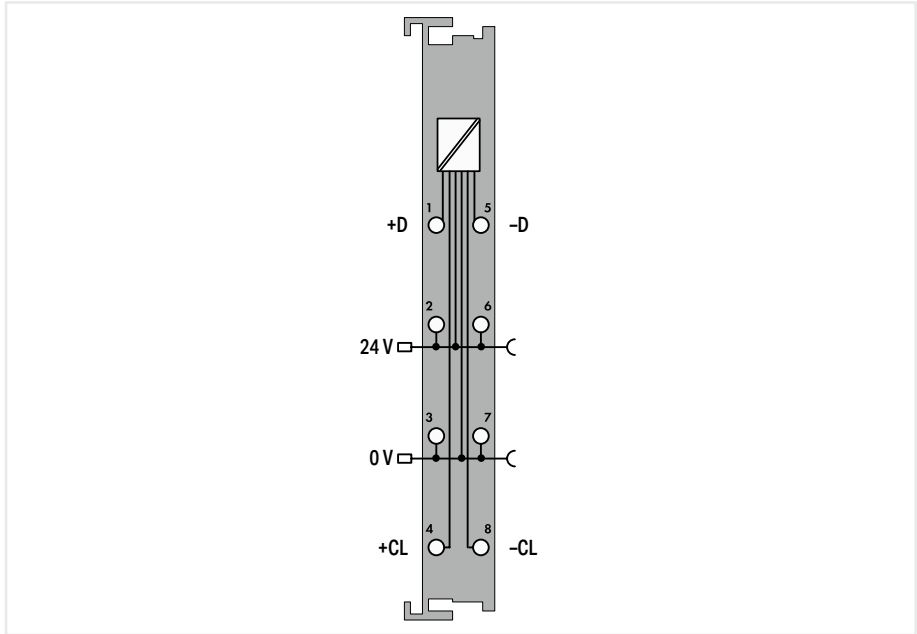

Item description	SSI Transmitter Interface; adjustable
Version	extreme
Item no.	750-630/040-001
Order Text	SSI Interface; Adjust; XTR
Technical data	
Encoder connection	On + D, -D / Off + Cl, - Cl
Supply voltage (encoder)	24 VDC; via power jumper contacts
Data transmission rate	125 kHz
Serial input	Data width: 1 ... 32 bits
Code	Gray code/binary code
Supply voltage (field)	24 VDC (-25 ... +30 %); via power jumper contacts (power supply via blade contact; transmission via spring contact); Derating must be observed!
Derating	Derating (supply voltage): Ambient temperatures under laboratory conditions: (-25 ... +30 %); for -40 ... +55 °C: 24 V (-25 ... +20 %); for +55 ... +70 °C: 24 V (-25 ... +10 %); Lower limit in all temperature ranges: -27.5 % (including 15 % residual ripple)
Current consumption (5 V system supply)	20 mA
Rated surge voltage	1 kV
Data width	1 x 32 bits; 1 x 8-bit control/status (optional) (24-bit data, 8 bits reserved)
Ambient temperature (operation)	-40 ... +70 °C
Dimensions W x H x D	(12 x 100 x 67.8) mm
Approvals	CE; Marine; OrdLoc/HazLoc; ATEX/IECEX
For data sheet and additional information, see:	wago.com/750-630/040-001

Serial interface



750-652/040-000

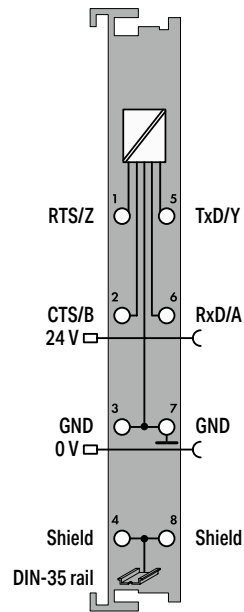

Item description	Serial Interface RS-232/485
Version	extreme
Item no.	750-652/040-000
Order Text	RS232/485 Interface; XTR
Technical data	
Signal type	RS-232; RS-422 / RS-485
Transmission channels	1 TxD / 1 RxD, full duplex, half duplex, 7- or 8-bit data, 1 or 2 stop bits
Baud rate	300 Bd ... 115.2 kBd
Number of data bits	7/8, adjustable
Number of stop bits	1/2, adjustable
Buffer	2560 bytes for reception / 512 bytes for transmission
Supply voltage (field)	24 VDC (-25 ... +30 %); via power jumper contacts (power supply via blade contact; transmission via spring contact); Derating must be observed!
Derating	Derating (supply voltage): Ambient temperatures under laboratory conditions: (-25 ... +30 %); for -40 ... +55 °C: 24 V (-25 ... +20 %); for +55 ... +70 °C: 24 V (-25 ... +10 %); Lower limit in all temperature ranges: -27.5 % (including 15 % residual ripple)
Current consumption (5 V system supply)	85 mA
Rated surge voltage	1 kV
Data width	8, 24 or 48 bytes (parameterizable)
Ambient temperature (operation)	-40 ... +70 °C
Dimensions W x H x D	(12 x 100 x 67.8) mm
Approvals	CE; Marine; OrdLoc/HazLoc; ATEX/IECEX

For data sheet and additional information, see:

wago.com/750-652/040-000

CAN gateway



750-658/040-000

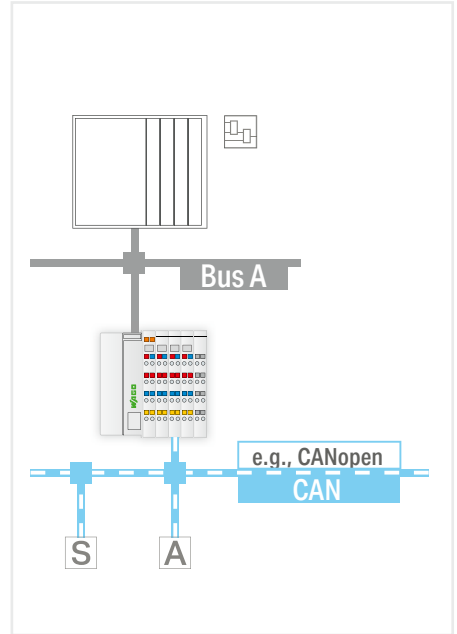
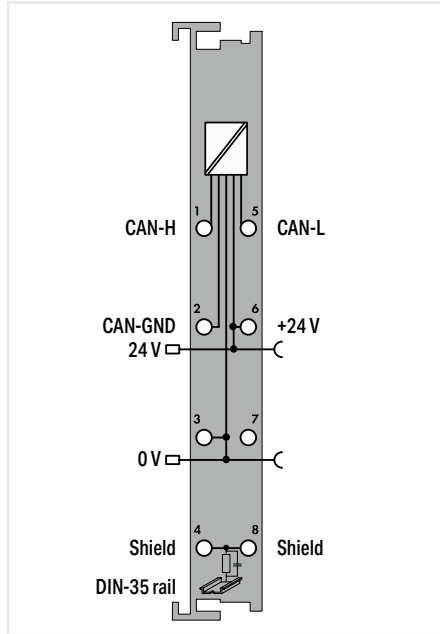

Item description	CAN Gateway
Version	extreme
Item no.	750-658/040-000
Order Text	CAN Gateway; XTR
Technical data	
Device-specific	Operating modes: Sniffer mode, transparent mode, mapped mode
Number of inputs	1 (CAN interface)
Transmission modes	10 kbit/s; 20 kbit/s; 50 kbit/s; 125 kbit/s; 250 kbit/s; 500 kbit/s; 800 kbit/s (auto-baudrate); Data formats: per 2.0 A standard (11-bit ID); per 2.0 B extended (29-bit ID)
Supply voltage (field)	24 VDC (-25 ... +30 %); via power jumper contacts (power supply via blade contact; transmission via spring contact); Derating must be observed!
Derating	Derating (supply voltage): Ambient temperatures under laboratory conditions: (-25 ... +30 %); for -40 ... +55 °C: 24 V (-25 ... +20 %); for +55 ... +70 °C: 24 V (-25 ... +10 %); Lower limit in all temperature ranges: -27.5 % (including 15 % residual ripple)
Current consumption (5 V system supply)	50 mA
Rated surge voltage	1 kV
Data width	Configurable to 8, 12, 16, 20, 24, 32, 40, 48 bytes; incl. control/status byte
Ambient temperature (operation)	-40 ... +70 °C
Dimensions W x H x D	(12 x 100 x 67.8) mm
Approvals	CE; Marine; OrdLoc/HazLoc; ATEX/IECEx
For data sheet and additional information, see:	wago.com/750-658/040-000

Operating modes: Sniffer mode, transparent mode, mapped mode
1 (CAN interface)
10 kbit/s; 20 kbit/s; 50 kbit/s; 125 kbit/s; 250 kbit/s; 500 kbit/s; 800 kbit/s (auto-baudrate); Data formats: per 2.0 A standard (11-bit ID); per 2.0 B extended (29-bit ID)
24 VDC (-25 ... +30 %); via power jumper contacts (power supply via blade contact; transmission via spring contact); Derating must be observed!
Derating (supply voltage): Ambient temperatures under laboratory conditions: (-25 ... +30 %); for -40 ... +55 °C: 24 V (-25 ... +20 %); for +55 ... +70 °C: 24 V (-25 ... +10 %); Lower limit in all temperature ranges: -27.5 % (including 15 % residual ripple)
50 mA
1 kV
Configurable to 8, 12, 16, 20, 24, 32, 40, 48 bytes; incl. control/status byte
-40 ... +70 °C
(12 x 100 x 67.8) mm
CE; Marine; OrdLoc/HazLoc; ATEX/IECEx
wago.com/750-658/040-000

The CAN Gateway allows a CAN bus to be installed as a sub-bus beneath a fieldbus coupler or controller. It enables special sensors/actuators that are only available with the widely used CAN bus to also be integrated under other bus systems. Function blocks allow the gateway to read and write higher-protocol telegrams, e.g., CANopen.

The module offers three different operating modes:

- Sniffer mode: Detailed analysis of the CAN bus through passive "snooping"
- Transparent mode: Active CAN subscriber that can send and receive any type of CAN telegram
- Mapped mode: Enables direct generation of CAN telegrams from the process image, or selective copying of process values from received CAN telegrams into the input process image (cyclic or event-based).

Supply module ▶ 24 VDC



750-602/040-000

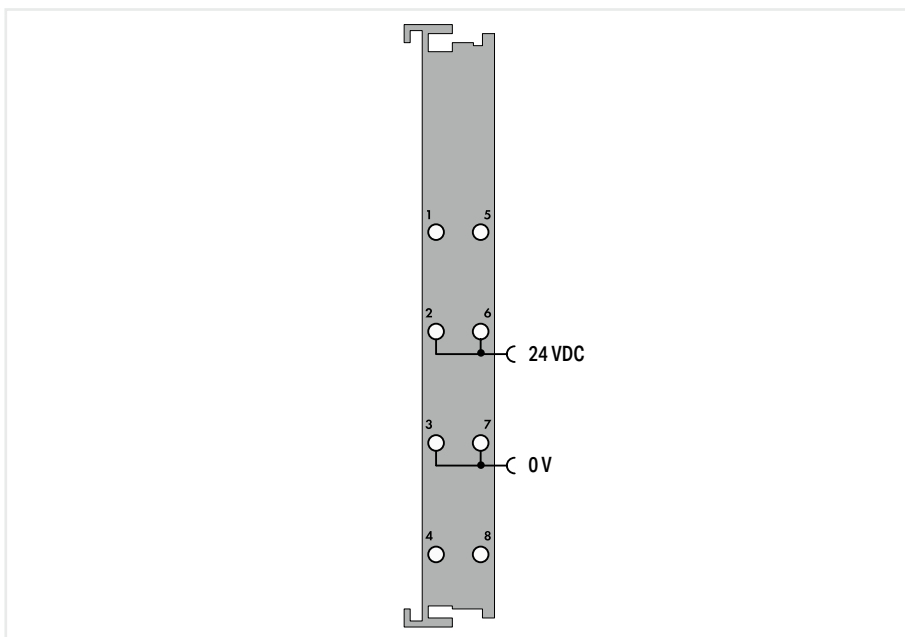

Item description	Power Supply; 24 VDC
Version	extreme
Item no.	750-602/040-000
Order Text	Power Supply; 24 VDC; XTR
Technical data	
Supply voltage (system)	5 VDC; via data contacts
Supply voltage (field)	24 VDC (-25 ... +30 %); via power jumper contacts (power supply via CAGE CLAMP® connection; transmission via spring contact); Derating must be observed!
Derating	Derating (supply voltage): Ambient temperatures under laboratory conditions: (-25 ... +30 %); for -40 ... +55 °C: 24 V (-25 ... +20 %); for +55 ... +70 °C: 24 V (-25 ... +10 %); Lower limit in all temperature ranges: -27.5 % (including 15 % residual ripple)
Current carrying capacity (power jumper contacts)	10 A
Rated surge voltage	1 kV
Ambient temperature (operation)	-40 ... +70 °C
Dimensions W x H x D	(12 x 100 x 67.8) mm
Approvals	CE; Marine; OrdLoc/HazLoc; ATEX/IECEx

For data sheet and additional information, see:

wago.com/750-602/040-000

This I/O module provides the applied supply voltage to the field devices connected to downstream I/O modules.

Supply module ▶ 24 VDC; fuse holder



750-601/040-000

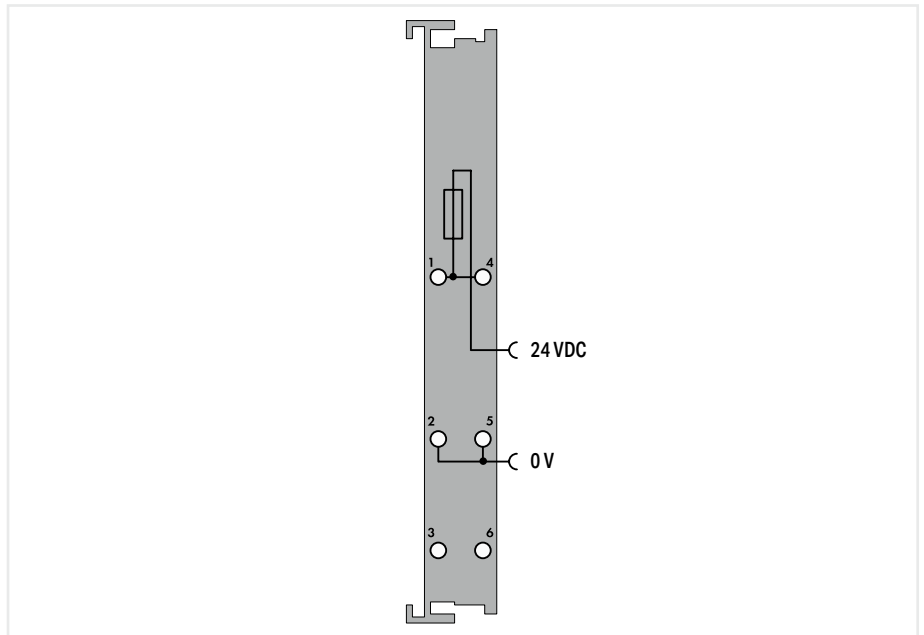

Item description	Power Supply; 24 VDC; Fuse holder
Version	extreme
Item no.	750-601/040-000
Order Text	Power Supply; 24 VDC; Fuse; XTR
Technical data	
Supply voltage (system)	5 VDC; via data contacts
Supply voltage (field)	24 VDC (-25 ... +30 %); via power jumper contacts (power supply via CAGE CLAMP® connection; transmission via spring contact); Derating must be observed!
Derating	Derating (supply voltage): Ambient temperatures under laboratory conditions: (-25 ... +30 %); for -40 ... +55 °C: 24 V (-25 ... +20 %); for +55 ... +70 °C: 24 V (-25 ... +10 %); Lower limit in all temperature ranges: -27.5 % (including 15 % residual ripple)
Current carrying capacity (power jumper contacts)	6.3 A
Rated surge voltage	1 kV
Fuse	5 x 20; T 6.3 A (not included)
Ambient temperature (operation)	-40 ... +70 °C
Dimensions W x H x D	(12 x 100 x 67.8) mm
Approvals	CE; Marine; OrdLoc/HazLoc; ATEX/IECEX
For data sheet and additional information, see:	wago.com/750-601/040-000

This I/O module provides the applied supply voltage, protected by a fuse, to the field devices connected to downstream I/O modules. A blown fuse is indicated by an LED.

Supply module ► 24 VDC; fuse holder; diagnostics



750-610/040-000

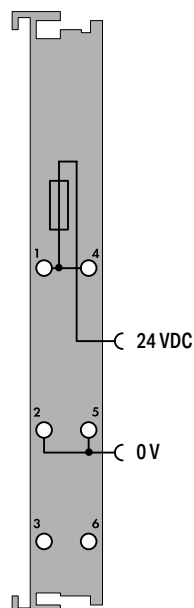

Item description	Power Supply; 24 VDC; Fuse holder; Diagnostics
Version	extreme
Item no.	750-610/040-000
Order Text	Power Supply; 24 VDC; Fuse; Diagn; XTR
Technical data	
Supply voltage (system)	5 VDC; via data contacts
Supply voltage (field)	24 VDC (-25 ... +30 %); via power jumper contacts (power supply via CAGE CLAMP® connection; transmission via spring contact); Derating must be observed!
Derating	Derating (supply voltage): Ambient temperatures under laboratory conditions: (-25 ... +30 %); for -40 ... +55 °C: 24 V (-25 ... +20 %); for +55 ... +70 °C: 24 V (-25 ... +10 %); Lower limit in all temperature ranges: -27.5 % (including 15 % residual ripple)
Current consumption (5 V system supply)	5 mA
Current carrying capacity (power jumper contacts)	6.3 A
Rated surge voltage	1 kV
Fuse	5 x 20; T 6.3 A (not included)
Diagnostics	Supply voltage (field): Detection "on" at > 15 VDC; Detection "off" at < 5 VDC
Data width	2 bits (1 bit current monitoring, 1 bit fuse fault)
Ambient temperature (operation)	-40 ... +70 °C
Dimensions W x H x D	(12 x 100 x 67.8) mm
Approvals	CE; Marine; OrdLoc/HazLoc; ATEX/IECEX

For data sheet and additional information, see:

wago.com/750-610/040-000

This I/O module provides the applied supply voltage, protected by a fuse, to the field devices connected to downstream I/O modules. A blown fuse is indicated by an LED. The fuse status can also be queried from the fieldbus coupler.

Supply module ▶ 0 ... 230 VAC/DC



750-612/040-000

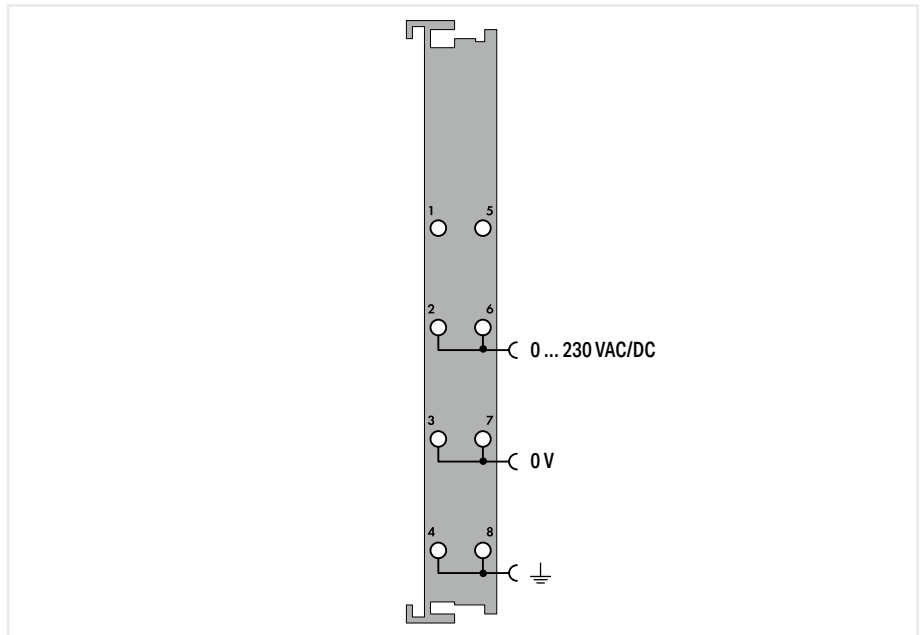

Item description	Power Supply; 0 ... 230 VAC/DC
Version	extreme
Item no.	750-612/040-000
Order Text	Power Supply; 0-230 VAC/VDC; XTR
Technical data	
Supply voltage (system)	5 VDC; via data contacts
Supply voltage (field)	230 VAC/DC (-20 ... +25 %); via power jumper contacts (power supply via CAGE CLAMP® connection; transmission via spring contact)
Current carrying capacity (power jumper contacts)	6.3 A
Rated surge voltage	5.0 kV (EN 60870-2-1 / Class VW3); 4.0 kV (UL 508); 6.4 kV (EN 61010-1 to 2000 m); 4.0 kV (EN 61010-1 to 5000 m)
Overvoltage category	Nominal voltage 230 V: III (EN 61010-1 / up to 2.000 m); II (EN 61010-1 / up to 5.000 m)
Ambient temperature (operation)	-40 ... +70 °C
Dimensions W x H x D	(12 x 100 x 67.8) mm
Approvals	 Marine; OrdLoc/HazLoc; ATEX/IECEX wago.com/750-612/040-000

For data sheet and additional information, see:

This I/O module provides the applied supply voltage to the field devices connected to downstream I/O modules.

System power supply ▶ 24 VDC; system power supply



750-613/040-000

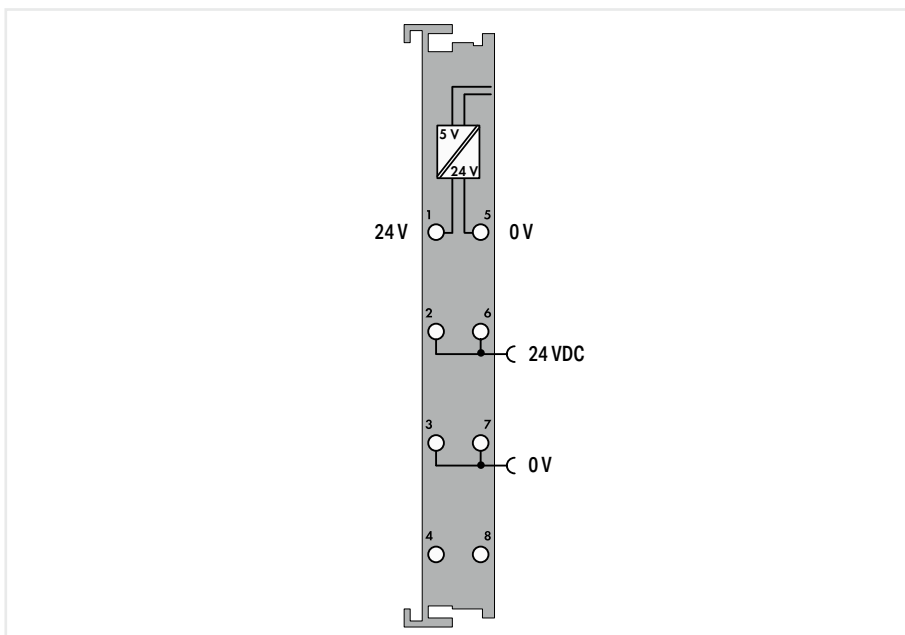

Item description

Version

Item no.

Order Text

System Power Supply; 24 VDC

extreme

750-613/040-000

System Power Supply; 24 VDC; XTR

Technical data

Supply voltage (system)

24 VDC (-25 ... +30 %); via pluggable connector (CAGE CLAMP® connection)

Input current (typ.) at nominal load (24 V)

500 mA

Power supply efficiency (typ.) at nominal load (24 V)

90 %

Supply voltage (field)

24 VDC (-25 ... +30 %); via power jumper contacts (power supply via CAGE CLAMP® connection; transmission via spring contact); Derating must be observed!

Derating

Derating (supply voltage): Ambient temperatures under laboratory conditions: (-25 ... +30 %); for -40 ... +55 °C: 24 V (-25 ... +20 %); for +55 ... +70 °C: 24 V (-25 ... +10 %); Lower limit in all temperature ranges: -27.5 % (including 15 % residual ripple)

Total current (system supply)

2000 mA

Current carrying capacity (power jumper contacts)

10 A

Rated surge voltage

1 kV

Ambient temperature (operation)

-40 ... +70 °C

Dimensions W x H x D

(12 x 100 x 67.8) mm

Approvals

CE, Marine, OrdLoc/HazLoc, ATEX/IECEx

For data sheet and additional information, see:

wago.com/750-613/040-000

This I/O module provides the applied supply voltage to the field devices connected to downstream I/O modules. It also serves as an additional system supply for large nodes, covering the I/O modules' power demands.

Potential distribution module ▶ 0 ... 230 VAC/DC



750-614/040-000

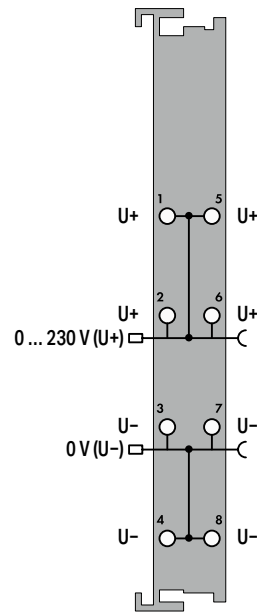

Item description	Potential Multiplication; 0 ... 230 VAC/DC
Version	extreme
Item no.	750-614/040-000
Order Text	Potential Distribution; 0-230 VAC/VDC; XTR
Technical data	
Supply voltage (system)	5 VDC; via data contacts
Supply voltage (field)	230 VAC/DC; via power jumper contacts (power supply via blade contact; transmission via spring contact)
Current carrying capacity (power jumper contacts)	10 A
Rated surge voltage	5.0 kV (EN 60870-2-1 / Class VW3); 6.0 kV (UL 61010); 6.0 kV (EN 60664-1 / to 4,000 m ASL); 4.0 kV (EN 60664-1 / > 4,000 m to 5,000 m ASL)
Ambient temperature (operation)	-40 ... +70 °C
Dimensions W x H x D	(12 x 100 x 67.8) mm
Approvals	CE; Marine; OrdLoc/HazLoc; ATEX/IECEX
For data sheet and additional information, see:	wago.com/750-614/040-000

Potential distribution module ▶ 16x 24 V



750-1605/040-000

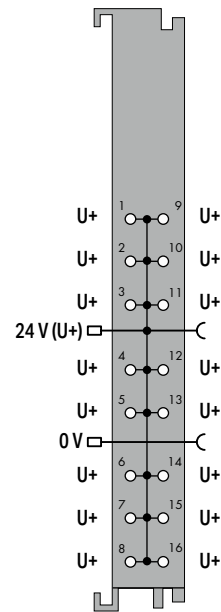

Item description	Potential Distribution; 16x 24 V
Version	extreme
Item no.	750-1605/040-000
Order Text	Potential Distribution; 16*24V; XTR
Technical data	
Supply voltage (system)	5 VDC; via data contacts
Supply voltage (field)	24 VDC (-25 ... +30 %); via power jumper contacts (power supply via blade contact; transmission via spring contact); Derating must be observed!
Derating	Derating (supply voltage): Ambient temperatures under laboratory conditions: (-25 ... +30 %); for -40 ... +55 °C: 24 V (-25 ... +20 %); for +55 ... +70 °C: 24 V (-25 ... +10 %); Lower limit in all temperature ranges: -27.5 % (including 15 % residual ripple)
Current carrying capacity (power jumper contacts)	10 A
Rated surge voltage	1 kV
Ambient temperature (operation)	-40 ... +70 °C
Dimensions W x H x D	(12 x 100 x 69) mm
Approvals	CE; Marine; OrdLoc/HazLoc; ATEX/IECEX

For data sheet and additional information, see:

wago.com/750-1605/040-000

Potential distribution module ▶ 16x 0 V



750-1606/040-000

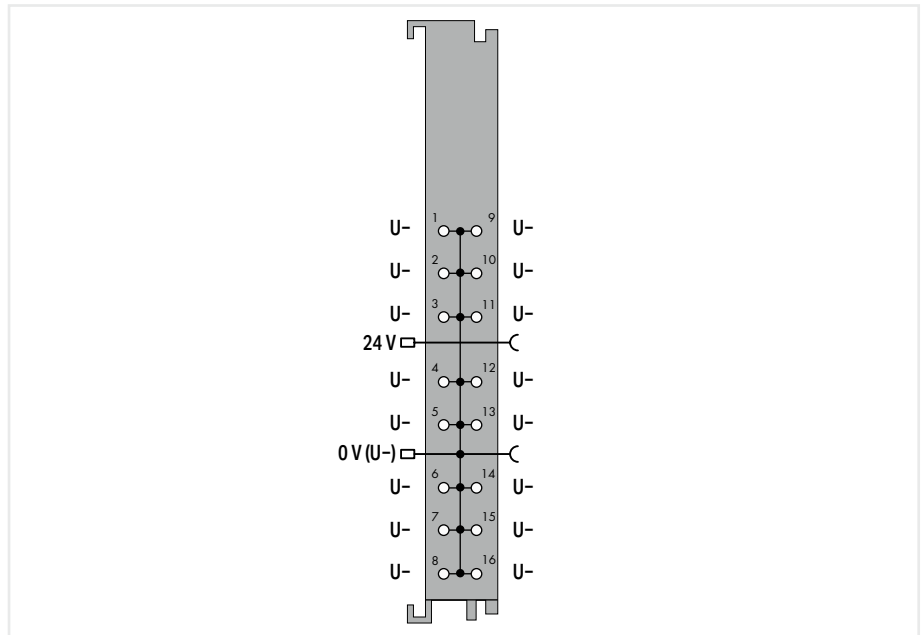

Item description	Potential Distribution; 16x 0 V
Version	extreme
Item no.	750-1606/040-000
Order Text	Potential Distribution; 16*0V; XTR
Technical data	
Supply voltage (system)	5 VDC; via data contacts
Supply voltage (field)	24 VDC (-25 ... +30 %); via power jumper contacts (power supply via blade contact; transmission via spring contact); Derating must be observed!
Derating	Derating (supply voltage): Ambient temperatures under laboratory conditions: (-25 ... +30 %); for -40 ... +55 °C: 24 V (-25 ... +20 %); for +55 ... +70 °C: 24 V (-25 ... +10 %); Lower limit in all temperature ranges: -27.5 % (including 15 % residual ripple)
Current carrying capacity (power jumper contacts)	10 A
Rated surge voltage	1 kV
Ambient temperature (operation)	-40 ... +70 °C
Dimensions W x H x D	(12 x 100 x 69) mm
Approvals	CE; Marine; OrdLoc/HazLoc; ATEX/IECEx
For data sheet and additional information, see:	wago.com/750-1606/040-000

Filter module ► Field supply filter



750-624/040-000

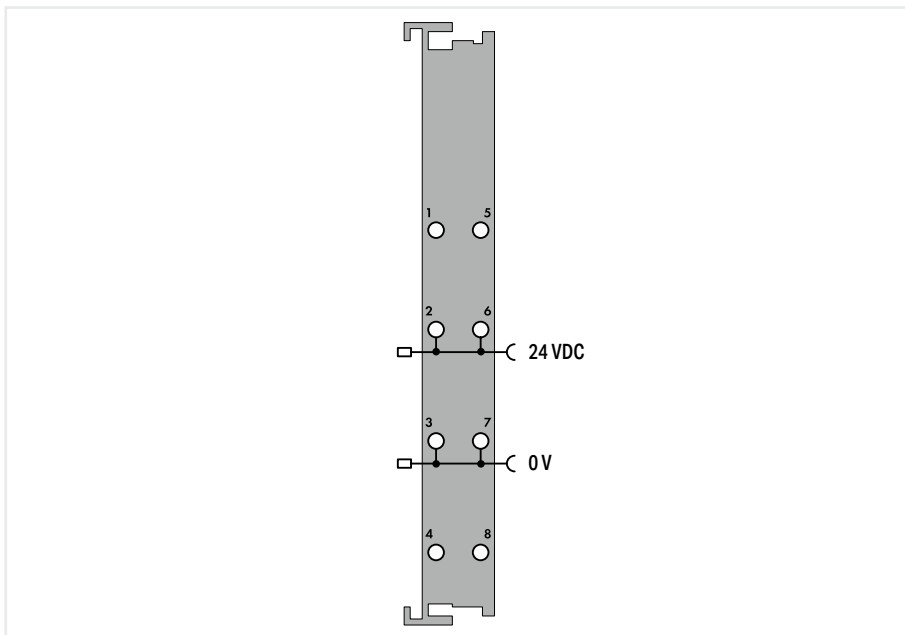

Item description	Field Supply Filter (Surge); 24 VDC; Higher isolation
Version	extreme
Item no.	750-624/040-000
Order Text	Field Supply Filter; 24 VDC; HI; XTR
Technical data	
Supply voltage (system)	5 VDC; via data contacts
Supply voltage (field)	24 VDC (-25 ... +30 %); via power jumper contacts (power supply via blade contact; transmission via spring contact); Derating must be observed!
Derating	Derating (supply voltage): Ambient temperatures under laboratory conditions: (-25 ... +30 %); for -40 ... +55 °C: 24 V (-25 ... +20 %); for +55 ... +70 °C: 24 V (-25 ... +10 %); Lower limit in all temperature ranges: -27.5 % (including 15 % residual ripple)
Current carrying capacity (power jumper contacts)	10 A
Rated surge voltage	1 kV
Application	in marine and onshore/offshore applications, as well as in telecontrol and rail technology
Ambient temperature (operation)	-40 ... +70 °C
Dimensions W x H x D	(12 x 100 x 67.8) mm
Approvals	CE; Marine; OrdLoc/HazLoc; ATEX/IECEX
For data sheet and additional information, see:	wago.com/750-624/040-000

Filter module ► Field supply filter; without power jumper contacts



750-624/040-001

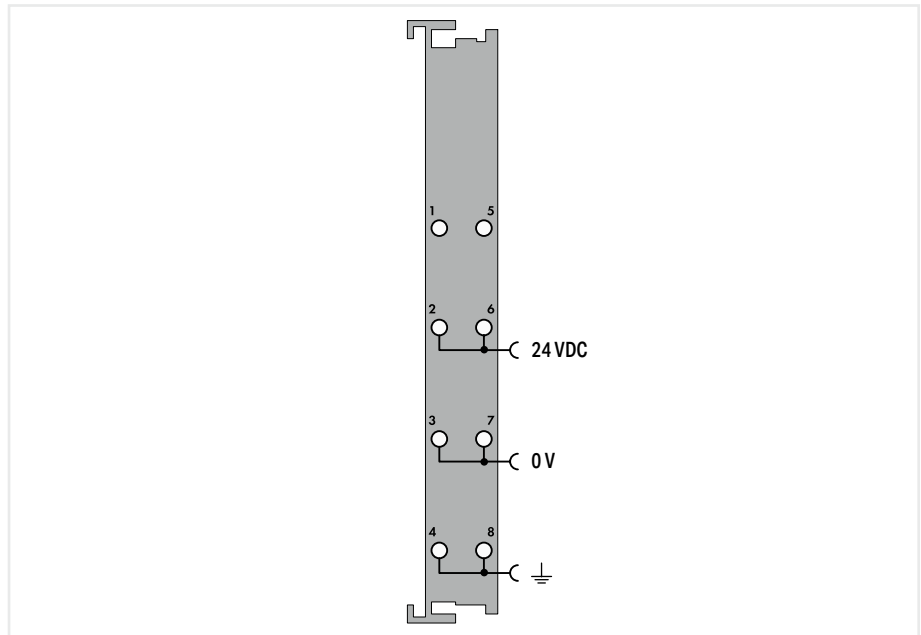

Item description	Field Supply Filter (Surge); 24 VDC; Higher isolation; without power jumper contacts
Version	extreme
Item no.	750-624/040-001
Order Text	Field Supply Filter; 24 VDC; HI; NC; XTR
Technical data	
Supply voltage (system)	5 VDC; via data contacts
Supply voltage (field)	24 VDC (-25 ... +30 %); via power jumper contacts (power supply via CAGE CLAMP® connection; transmission via spring contact); Derating must be observed!
Derating	Derating (supply voltage): Ambient temperatures under laboratory conditions: (-25 ... +30 %); for -40 ... +55 °C: 24 V (-25 ... +20 %); for +55 ... +70 °C: 24 V (-25 ... +10 %); Lower limit in all temperature ranges: -27.5 % (including 15 % residual ripple)
Current carrying capacity (power jumper contacts)	10 A
Rated surge voltage	1 kV
Application	in marine and onshore/offshore applications, as well as in telecontrol and rail technology
Ambient temperature (operation)	-40 ... +70 °C
Dimensions W x H x D	(12 x 100 x 67.8) mm
Approvals	CE; Marine; OrdLoc/HazLoc; ATEX/IECEx
For data sheet and additional information, see:	wago.com/750-624/040-001

Filter module ► Power supply filter



750-626/040-000

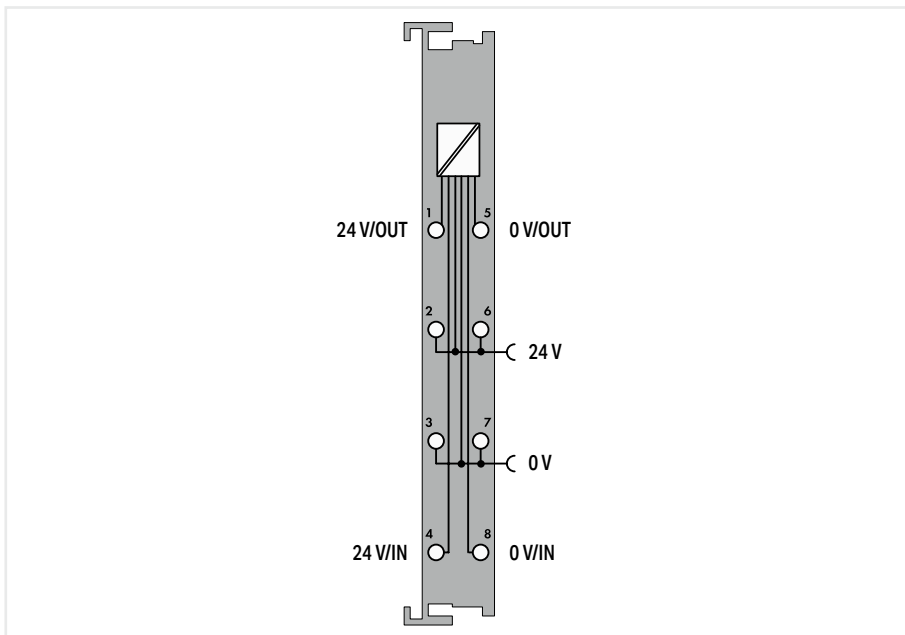

Item description

Version

Item no.

Order Text

Technical data

Supply voltage (system)

Supply voltage (field)

Derating

Current via system voltage (max.)

Current carrying capacity (power jumper contacts)

Rated surge voltage

Application

Ambient temperature (operation)

Dimensions W x H x D

Approvals

For data sheet and additional information, see:

Supply Filter; 24 VDC; Higher isolation

extreme

750-626/040-000

Supply Filter; 24 VDC; HI; XTR

24 VDC (-25 ... +30 %); via pluggable connector (CAGE CLAMP® connection)

24 VDC (-25 ... +30 %); via power jumper contacts (power supply via CAGE CLAMP® connection; transmission via spring contact); Derating must be observed!

Derating (supply voltage): Ambient temperatures under laboratory conditions: (-25 ... +30 %); for -40 ... +55 °C: 24 V (-25 ... +20 %); for +55 ... +70 °C: 24 V (-25 ... +10 %); Lower limit in all temperature ranges: -27.5 % (including 15 % residual ripple)

1.5 A

10 A

1 kV

in marine and onshore/offshore applications, as well as in telecontrol and rail technology

-40 ... +70 °C

(12 x 100 x 67.8) mm

CE; Marine; OrdLoc/HazLoc; ATEX/IECEX

wago.com/750-626/040-000

Distance module



750-616/040-000

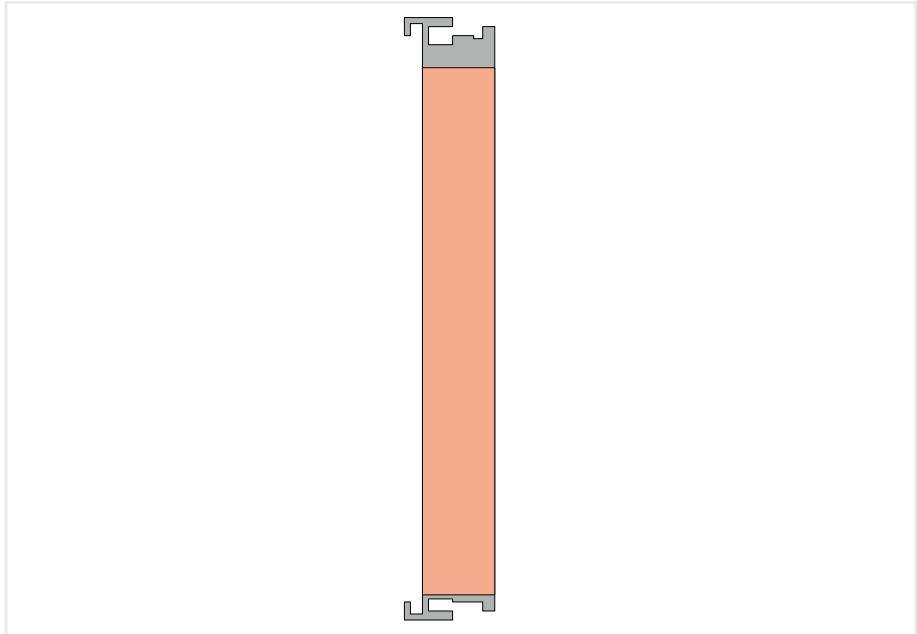

Item description
Version
Item no.
Order Text

Distance Module
extreme
750-616/040-000
Distance Module; XTR

Technical data
Supply voltage (system)
Ambient temperature (operation)
Dimensions W x H x D
Approvals

5 VDC; via data contacts
-40 ... +70 °C
(12 x 100 x 69.8) mm
CE; Marine; OrdLoc/HazLoc; ATEX/IECEX
wago.com/750-616/040-000

For data sheet and additional information, see:

This distance module visually divides a fieldbus node into sections.
 Notice:
 Power supply to the adjacent I/O modules is performed via the power jumper contacts and requires an appropriate supply module.

Bus end module



750-600/040-000

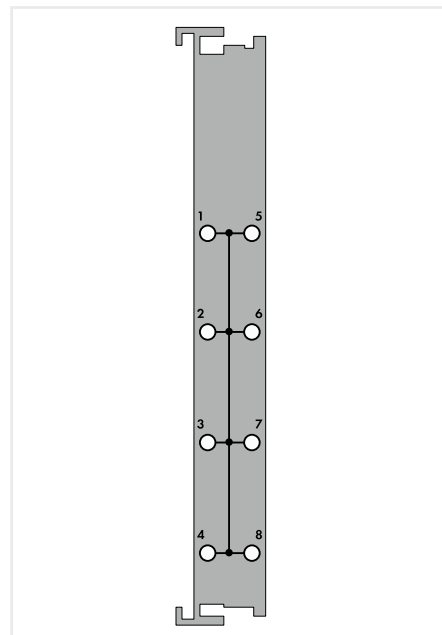
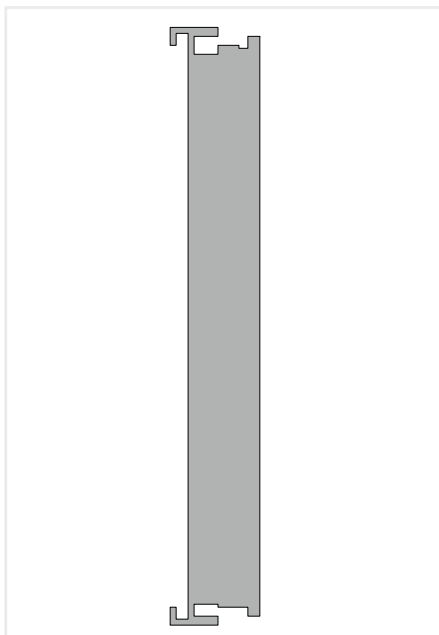

Item description
Version
Item no.
Order Text

End Module
extreme
750-600/040-000
End Module; XTR

End Module; with Potential Group
extreme
750-600/040-001
End Module; with Potential Group; XTR

Technical data
Supply voltage (system)
Voltage (potential group)
Rated surge voltage

-
-
-

5 VDC; via data contacts
0 ... 230 VAC/DC; Supply via CAGE CLAMP® contacts
5 kV per EN 60870-2-1 / Class VW3, or 6.4 kV per EN 61010-1

Ambient temperature (operation)
Dimensions W x H x D
Approvals

-40 ... +70 °C
(12 x 100 x 67.8) mm
CE; Marine; OrdLoc/HazLoc; ATEX/IECEx

-40 ... +70 °C
(12 x 100 x 67.8) mm
CE; Marine; OrdLoc/HazLoc

For data sheet and additional information, see:

wago.com/750-600/040-000

wago.com/750-600/040-000

An end module must be snapped onto the assembly at the end of a fieldbus node.
The end module completes the internal data bus, ensuring flawless data transmission.

An end module must be snapped onto the assembly at the end of a fieldbus node.
In addition, the eight CAGE CLAMP® connections form a potential group.
The end module completes the internal local data bus, ensuring flawless data transmission.

Intrinsically Safe XTR Modules



Specialty Housing

Dimensions W x H x D	48 x 100 x 70.9 mm
Depth from upper edge of DIN-rail	63.7 mm
Connection technology	CAGE CLAMP®
Conductor cross-section	0.25 ... 1.5 mm ² / 24 ... 14 AWG
Strip length	5 ... 6 mm / 0.22 inch

Housing Design (750 Series)

Dimensions W x H x D	12 or 24 x 100 x 67.8 mm
Depth from upper edge of DIN-rail	60.6 mm
Connection technology	CAGE CLAMP®
Conductor cross-section	0.25 ... 2.5 mm ² / 24 ... 14 AWG
Strip length	8 ... 9 mm / 0.33 inch



Use in Hazardous Locations in eXTReme Environments

In many plants across the oil and gas industry, along with those in the chemical and petrochemical industries and the process automation sector, installations are operated that process explosive gas- or dust-air mixtures under extreme conditions. This is why electrical equipment must be explosion-proof in order to avoid injuries to personnel and damage to facilities. When used in hazardous areas of Zone 2/22, the I/O System 750 XTR offers a safe, easy and economical connection to the sensors/actuators of Zones 0/20 and 1/21. Surrounding air temperatures from -40 to $+70^{\circ}\text{C}$ are permissible, as well as increased vibration loads up to 5g. The "blue" Ex i XTR I/O Modules were specially developed for this purpose. They form an intrinsically safe section that can be integrated into a standard 750 XTR Series node, offering all the advantages of state-of-the-art fieldbus technology. The WAGO I/O System 750 XTR is also approved for mining applications.

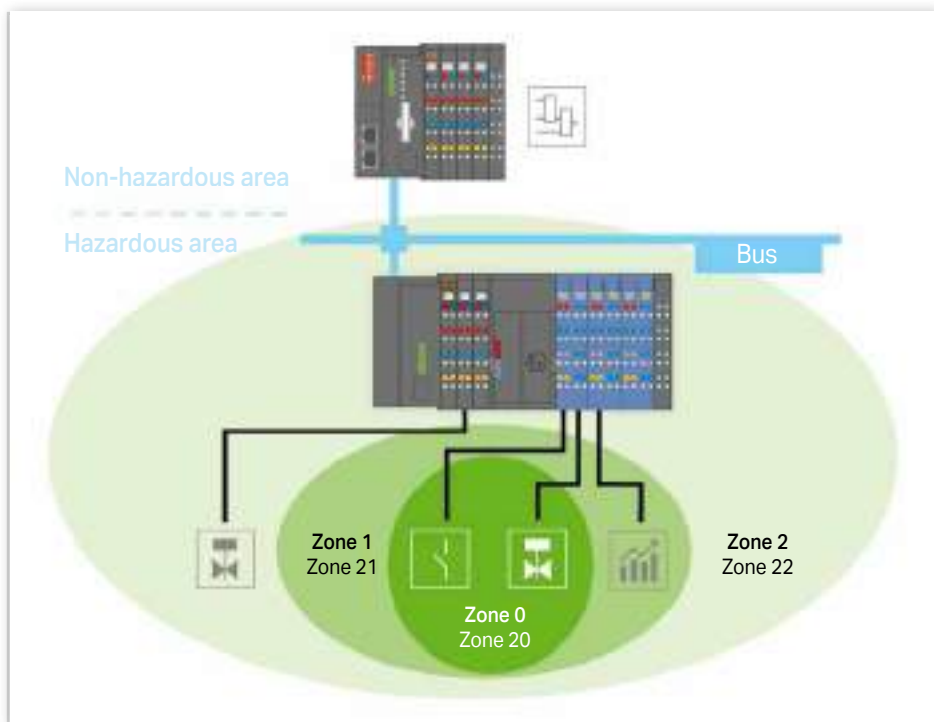

Intrinsically safe modules (Ex i) ▶ Supply module



750-606/040-000

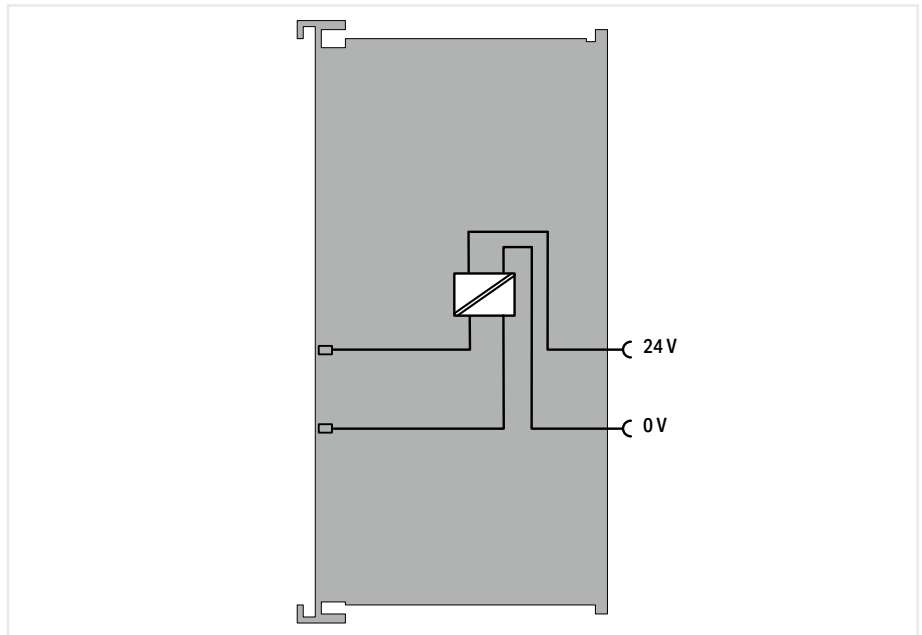

Item description	Power Supply; 24 VDC; Diagnostics; Intrinsically safe
Version	extreme
Item no.	750-606/040-000
Order Text	Power Supply; 24 VDC; Ex i; XTR
Technical data	
Current consumption (5 V system supply)	7.5 mA
Supply voltage (field)	24 VDC (-25 ... +30 %); via power jumper contacts (power supply via CAGE CLAMP® connection; transmission via spring contact); Derating must be observed!
Derating	Derating (supply voltage): Ambient temperatures under laboratory conditions: (-25 ... +30 %); for -40 ... +55 °C: 24 V (-25 ... +20 %); for +55 ... +70 °C: 24 V (-25 ... +10 %); Lower limit in all temperature ranges: -27.5 % (including 15 % residual ripple)
Current carrying capacity (power jumper contacts)	1 A
Fuse	electronic
Data width	2 bits (input voltage failure, fuse triggered)
Ambient temperature (operation)	-40 ... +70 °C
Dimensions W x H x D	(48 x 100 x 70.9) mm
Explosion protection	
Power supply (input)	$U_n = 24 \text{ VDC}; P_{\text{max.}} = 29 \text{ W}; U_m = 253 \text{ V}$
Power supply (output)	$U_o = 26.8 \text{ V}$ (intrinsically safe output voltage per protection level ia); $I_n = 1 \text{ A}$
Ex standard	EN/IEC 60079-0, -7, -11
Approvals	CE; Marine; OrdLoc/HazLoc; ATEX/IECEX
Marking	ATEX/IECEX: II 3G Ex ec IIC T4 Gc
For data sheet and additional information, see:	wago.com/750-606/040-000

This supply module monitors the power supply to the downstream Ex i segment and separates the intrinsically safe from the non-intrinsically safe section of the I/O system. The input and output sides are electrically isolated from each other.

Note: If, due to load conditions, more than one supply module is required per station, four distance modules (750-616/040-000) must be placed between the intrinsically safe sections.

General information (e.g., installation regulations) on explosion protection is available in the WAGO I/O System 750 XTR manuals!

Intrinsically safe modules (Ex i) ▶ Digital input



750-439/040-000

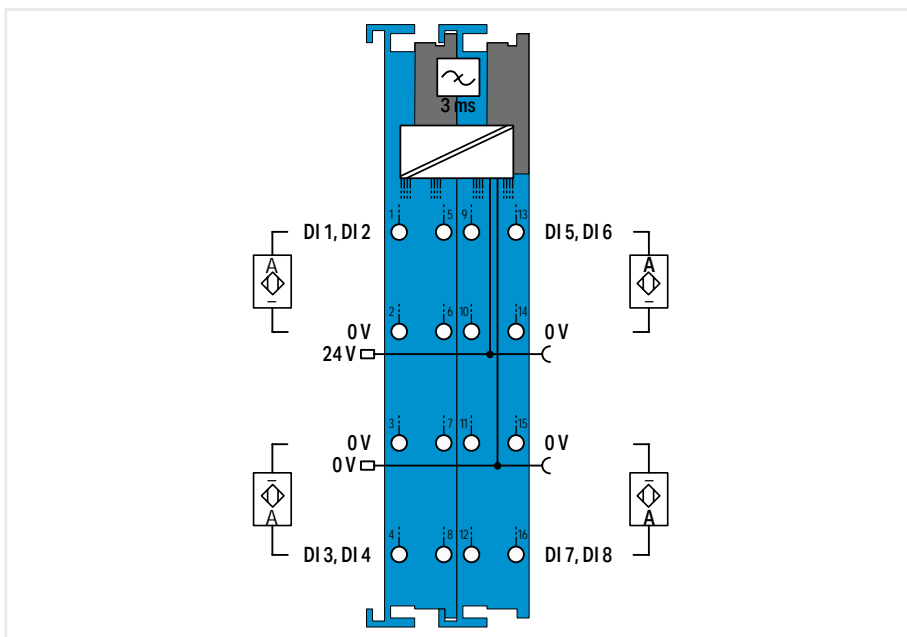

Item description	8-Channel Digital Input; NAMUR; Intrinsically safe
Version	extreme
Item no.	750-439/040-000
Order Text	8DI; NAMUR; Ex i; XTR
Technical data	
Number of digital inputs	8
Signal type	NAMUR
Sensor connection	4 x (2-wire)
Input characteristic	high-side switching
Input filter (digital)	3 ms
Open-circuit voltage	8.2 V
Diagnostics	Short circuit, wire break
Supply voltage (sensor)	8.2 VDC; short-circuit-protected, each channel supplied separately
Supply voltage (field)	24 VDC; (Ex i XTR power supply: $U_o = \max. 26.8 \text{ V}$); via power jumper contacts (power supply via blade contact; transmission via spring contact)
Current consumption, field supply (module with no external load)	11 mA
Current consumption (5 V system supply)	56 mA
Input data width (internal) max.	16 bits
Output data width (internal) max.	16 bits
Isolation	300 VAC system/field
Ambient temperature (operation)	-40 ... +70 °C
Dimensions W x H x D	(24 x 100 x 67.8) mm
Explosion protection	
Safety-relevant data (circuit)	$U_o = 11.76 \text{ V}$; $I_o = 12.48 \text{ mA}$; $P_o = 36.67 \text{ mW}$; linear characteristic curve
Reactances Ex ia IIC	$L_o = 100 \text{ mH}$; $C_o = 1.5 \mu\text{F}$
Reactances Ex ia IIB	$L_o = 100 \text{ mH}$; $C_o = 9.9 \mu\text{F}$
Reactances Ex ia IIA	$L_o = 100 \text{ mH}$; $C_o = 39 \mu\text{F}$
Reactances Ex ia I	$L_o = 100 \text{ mH}$; $C_o = 38 \mu\text{F}$
Reactances (note)	Reactances without accounting for the concurrence of capacitance (C_o) and inductance (L_o)
Ex standard	EN/IEC 60079-0, -7, -11
Approvals	CE; Marine; OrdLoc/HazLoc; ATEX/IECEx
Marking	ATEX/IECEx: II 3 (1) G Ex ec [ia Ga] IIC T4 Gc; II (1) D [Ex ia Da] IIC; I (M1) [Ex ia Ma] I
For data sheet and additional information, see:	wago.com/750-439/040-000

Intrinsically safe modules (Ex i) ► Digital output



750-535/040-000

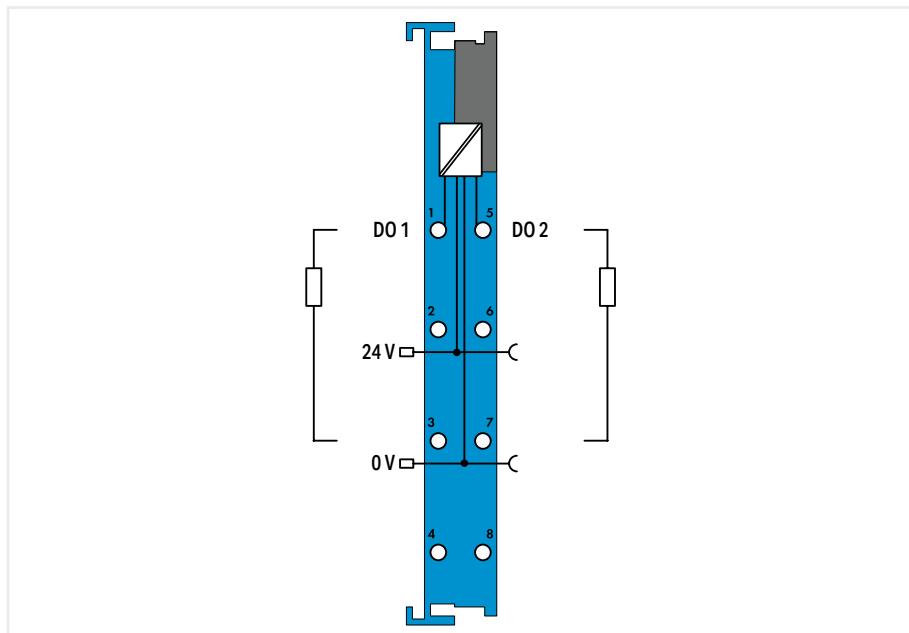

Item description	2-Channel Digital Output; 24 VDC; Intrinsically safe
Version	extreme
Item no.	750-535/040-000
Order Text	2DO; 24 VDC; Ex i; XTR
Technical data	
Number of digital outputs	2
Signal type	Digital
Signal type (voltage)	24 VDC
Output characteristic	high-side switching
Load type	Resistive, inductive, lamp load
Actuator connection	2 x (2-wire)
Switching frequency (max.)	1 kHz
Supply voltage (field)	24 VDC; (Ex i XTR power supply: $U_o = \text{max. } 26.8 \text{ V}$); via power jumper contacts (power supply via blade contact; transmission via spring contact)
Current consumption, field supply (module with no external load)	8.5 mA
Current consumption (5 V system supply)	7 mA
Output data width (internal) max.	2 bits
Isolation	300 VAC system/field
Ambient temperature (operation)	-40 ... +70 °C
Dimensions W x H x D	(12 x 100 x 67.8) mm
Explosion protection	
Safety-relevant data (circuit)	$U_o = 26.8 \text{ V}$; $I_o = 99.91 \text{ mA}$; $P_o = 669.43 \text{ mW}$; linear characteristic curve
Reactances Ex ia IIC	$L_o = 1.1 \text{ mH}$; $C_o = 0.092 \mu\text{F}$
Reactances Ex ia IIB	$L_o = 12 \text{ mH}$; $C_o = 0.72 \mu\text{F}$
Reactances Ex ia IIA	$L_o = 21 \text{ mH}$; $C_o = 2.37 \mu\text{F}$
Reactances Ex ia I	$L_o = 30 \text{ mH}$; $C_o = 3.85 \mu\text{F}$
Reactances (note)	Reactances without accounting for the concurrence of capacitance (C_o) and inductance (L_o)
Ex standard	EN/IEC 60079-0, -7, -11
Approvals	CE; Marine; OrdLoc/HazLoc; ATEX/IECEX
Marking	ATEX/IECEX: II 3 (1) G Ex ec [ia Ga] IIC T4 Gc; II (1) D [Ex ia Da] IIIC; I (M1) [Ex ia Ma] I
For data sheet and additional information, see:	wago.com/750-535/040-000

Intrinsically safe modules (Ex i) ▶ Analog input ▶ 0/4 ... 20 mA; NAMUR NE43



750-486/040-000

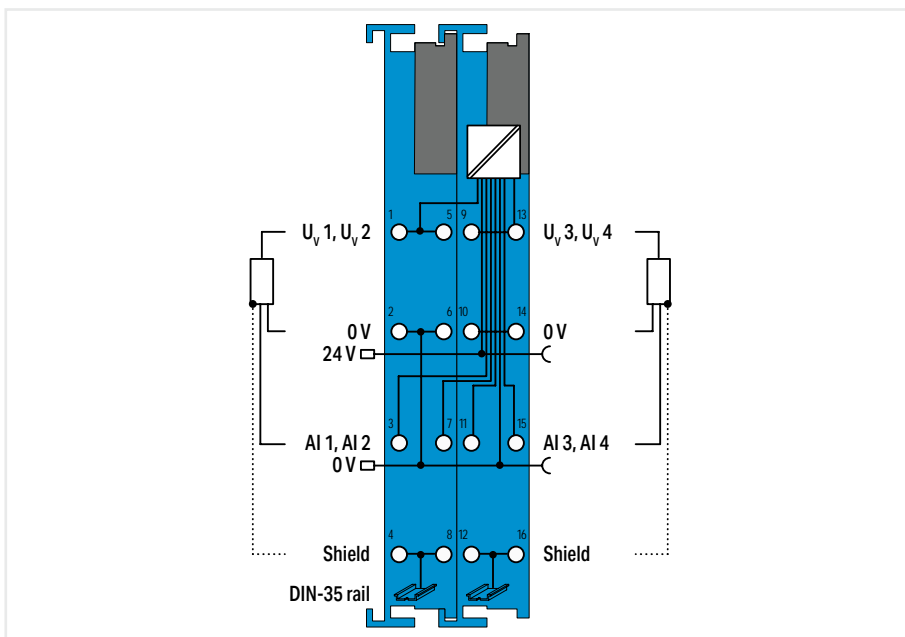

Item description	4-Channel Analog Input; 0/4 ... 20 mA; NAMUR NE43; Intrinsically safe
Version	extreme
Item no.	750-486/040-000
Order Text	4AI; 0/4-20mA; Ex i; XTR
Technical data	
Number of analog inputs	4
Signal type	Current
Signal type (current)	0 ... 20 mAADC; 4 ... 20 mAADC; 3.6 ... 21 mAADC
Sensor connection	2 x (3-wire)
Signal characteristics	Single-ended
Resolution [bit]	12 bits
Conversion time (typ.)	10 ms
Input resistance (max.)	200 Ω
Measurement error (reference temperature)	25 °C
Measurement error, deviation (max.) from the upper-range value	0.1 %
Temperature error (max.) of the upper-range value	0.01 %/K
Supply voltage (sensor)	15 VDC; Transmitter supply U_V at 20 mA
Supply voltage (field)	24 VDC; (Ex i XTR power supply: $U_0 = \max. 26.8 \text{ V}$); via power jumper contacts (power supply via blade contact; transmission via spring contact)
Current consumption, field supply (module with no external load)	19 mA
Current consumption (5 V system supply)	45 mA
Data width	4 x 16-bit data; 4 x 8-bit control/status (optional)
Isolation	300 VAC system/field
Ambient temperature (operation)	-40 ... +70 °C
Dimensions W x H x D	(24 x 100 x 67.8) mm
Explosion protection	
Safety-relevant data (circuit)	$U_0 = 26.8 \text{ V}$; $I_0 = 92.72 \text{ mA}$; $P_0 = 621.27 \text{ mW}$; linear characteristic curve
Reactances Ex ia IIC	$L_0 = 1.6 \text{ mH}$; $C_0 = 0.082 \mu\text{F}$
Reactances Ex ia IIB	$L_0 = 15 \text{ mH}$; $C_0 = 0.71 \mu\text{F}$
Reactances Ex ia IIA	$L_0 = 25 \text{ mH}$; $C_0 = 2.36 \mu\text{F}$
Reactances Ex ia I	$L_0 = 36 \text{ mH}$; $C_0 = 3.84 \mu\text{F}$
Reactances (note)	Reactances without accounting for the concurrence of capacitance (C_0) and inductance (L_0)
Ex standard	EN/IEC 60079-0, -7, -11
Approvals	CE; Marine; OrdLoc/HazLoc; ATEX/IECEx
Marking	ATEX/IECEx: II 3 (1) G Ex ec [ia Ga] IIC T4 Gc; II (1) D [Ex ia Da] IIIC; I (M1) [Ex ia Ma] I
For data sheet and additional information, see:	wago.com/750-486/040-000

Intrinsically safe modules (Ex i) ▶ Analog input ▶ 4 ... 20 mA HART



750-484/040-000

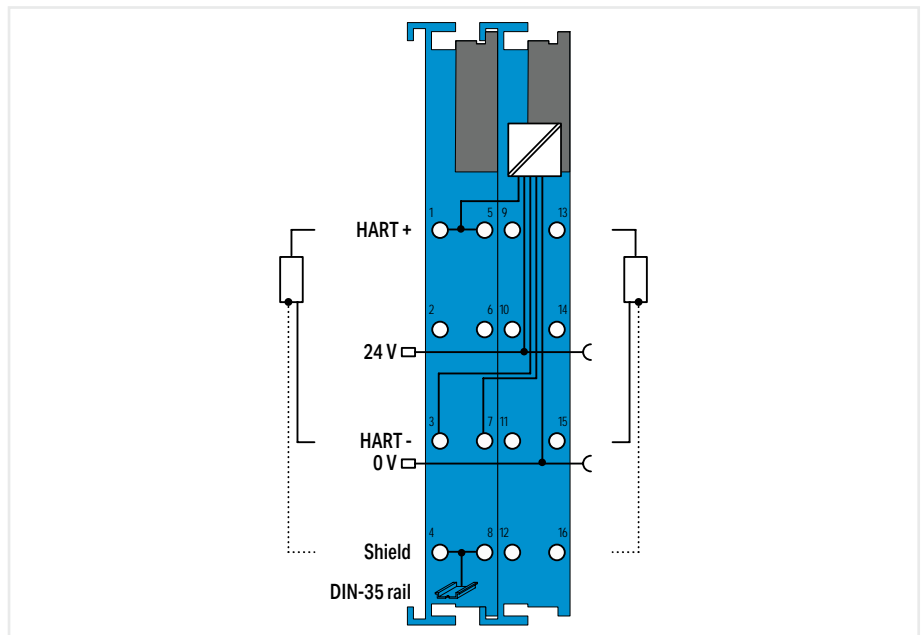

Item description	2-Channel Analog Input; 4 ... 20 mA HART; Intrinsically safe
Version	extreme
Item no.	750-484/040-000
Order Text	2AI; 4-20mA HART; Ex i; XTR
Technical data	
Number of analog inputs	2
Signal type	Current
Signal type (current)	4 ... 20 mA DC
Sensor connection	2 x (2-wire)
Input filter	parameterizable
Signal characteristics	Single-ended
Resolution [bit]	12 bits
Conversion time (typ.)	10 ms
Measurement error (reference temperature)	25 °C
Measurement error, deviation (max.) from the upper-range value	0.2 %
Temperature error (max.) of the upper-range value	0.01 %/K
Overvoltage protection	30 V, reverse polarity protected
Diagnostics	Wire break, measurement range overflow
Supply voltage (sensor)	16.5 VDC; Transmitter supply U_o at 20 mA
Supply voltage (field)	24 VDC; (Ex i XTR power supply: U_o = max. 26.8 V); via power jumper contacts (power supply via blade contact; transmission via spring contact)
Current consumption, field supply (module with no external load)	26 mA
Current consumption (5 V system supply)	25 mA
Data width	2 x 2-byte data; 2 x 2-byte data + 2n x 4-byte data (n = number of dynamic variables); 2 x 2-byte data + 6-byte mailbox
Isolation	300 VAC system/field
Ambient temperature (operation)	-40 ... +70 °C
Dimensions W x H x D	(24 x 100 x 67.8) mm
Explosion protection	
Safety-relevant data (circuit)	U_o = 26.8 V; I_o = 90.07 mA; P_o = 603.5 mW; linear characteristic curve
Reactances Ex ia IIC	L_o = 1.8 mH; C_o = 0.092 μ F
Reactances Ex ia IIB	L_o = 16 mH; C_o = 0.72 μ F
Reactances Ex ia IIA	L_o = 27 mH; C_o = 2.37 μ F
Reactances Ex ia I	L_o = 38 mH; C_o = 3.85 μ F
Reactances (note)	Reactances without accounting for the concurrence of capacitance (C_o) and inductance (L_o)
Ex standard	EN/IEC 60079-0, -7, -11
Approvals	CE; Marine; OrdLoc/HazLoc; ATEX/IECEx
Marking	ATEX/IECEx: II 3 (1) G Ex ec [ia Ga] IIC T4 Gc; II (1) D [Ex ia Da] IIC; I (M1) [Ex ia Ma] I
For data sheet and additional information, see:	wago.com/750-484/040-000

In addition to analog signal processing, this module offers optional HART communication for parameterizing or recording dynamic variables.

Intrinsically safe modules (Ex i) ▶ Analog input ▶ Resistance sensors



750-481/040-000

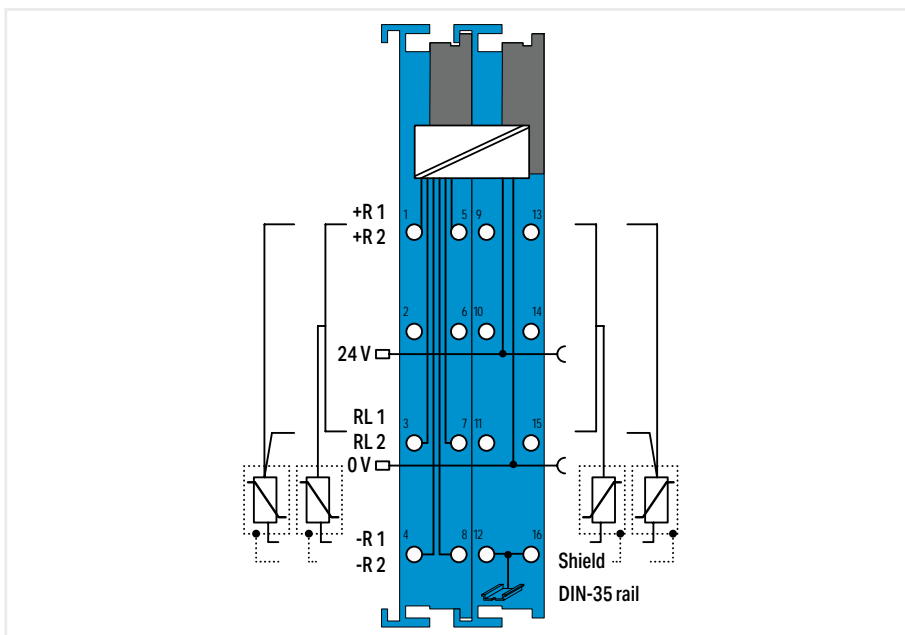

Item description	2-Channel Analog Input; RTD; Intrinsically safe
Version	extreme
Item no.	750-481/040-000
Order Text	2AI; RTD; Ex i; XTR
Technical data	
Number of analog inputs	2
Signal type	Resistance measurement; Potentiometer positions
Temperature range	-200 ... +850 °C (Pt), -60 ... +250 °C (Ni), -80 ... +320 °C (Ni120)
Sensor connection	2 x (2-wire, 3-wire)
Resolution (over entire range)	0.1 °C, 0.1 Ω, 0.0049 %
Conversion time (typ.)	325 ms
Conversion time	150 ... 500 ms (per channel)
Measurement error (reference temperature)	25 °C
Measurement error, deviation (max.) from the upper-range value	0.2 %
Temperature error (max.) of the upper-range value	0.01 %/K
Supply voltage (field)	24 VDC; (Ex i XTR power supply: $U_o = \max. 26.8 \text{ V}$); via power jumper contacts (power supply via blade contact; transmission via spring contact)
Current consumption, field supply (module with no external load)	12 mA
Current consumption (5 V system supply)	25 mA
Data width	2 x 16-bit data; 2 x 8-bit control/status (optional)
Isolation	300 VAC system/field
Ambient temperature (operation)	-40 ... +70 °C
Dimensions W x H x D	(24 x 100 x 67.8) mm
Explosion protection	
Safety-relevant data (circuit)	$U_o = 7.2 \text{ V}$; $I_o = 5.8 \text{ mA}$; $P_o = 10.5 \text{ mW}$; linear characteristic curve
Reactances Ex ia IIC	$L_o = 100 \text{ mH}$; $C_o = 13.5 \mu\text{F}$
Reactances Ex ia IIB	$L_o = 100 \text{ mH}$; $C_o = 240 \mu\text{F}$
Reactances Ex ia IIA	$L_o = 100 \text{ mH}$; $C_o = 1000 \mu\text{F}$
Reactances Ex ia I	$L_o = 100 \text{ mH}$; $C_o = 1000 \mu\text{F}$
Reactances (note)	Reactances without accounting for the concurrence of capacitance (C_o) and inductance (L_o)
Ex standard	EN/IEC 60079-0, -7, -11
Approvals	CE; Marine; OrdLoc/HazLoc; ATEX/IECEX
Marking	ATEX/IECEX: II 3 (1) G Ex ec [ja Ga] IIC T4 Gc; II (1) D [Ex ia Da] IIIC; I (M1) [Ex ia Ma] I
For data sheet and additional information, see:	wago.com/750-481/040-000

Intrinsically safe modules (Ex i) ► Analog output



750-585/040-000

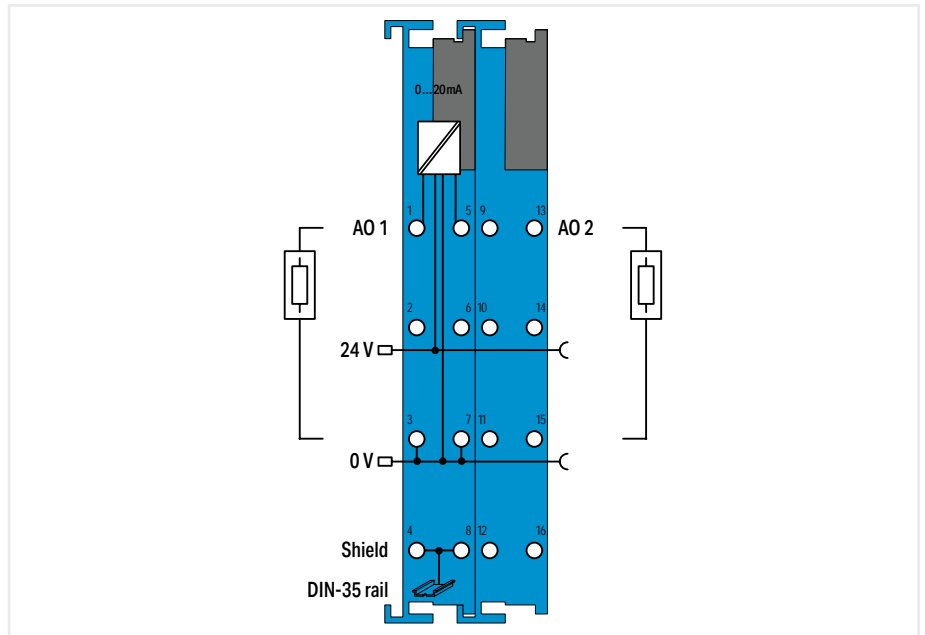

Item description	2-Channel Analog Output; 0 ... 20 mA; Intrinsically safe
Version	extreme
Item no.	750-585/040-000
Order Text	2AO; 0-20mA; Ex i; XTR
Technical data	
Number of analog outputs	2
Signal type	Current
Signal type (current)	0 ... 20 mA DC
Signal characteristics	Single-ended
Load impedance (current output) max.	500 Ω
Resolution [bit]	12 bits
Conversion time (typ.)	2 ms
Output error, reference temperature	25 °C
Output error, deviation (max.) of the upper-range value	0.2 %
Temperature error (max.) of the output range value	0.01 %/K
Actuator connection	2 x (2-wire)
Supply voltage (field)	24 VDC; (Ex i XTR power supply: $U_o = \text{max. } 26.8 \text{ V}$); via power jumper contacts (power supply via blade contact; transmission via spring contact)
Current consumption, field supply (module with no external load)	19 mA
Current consumption (5 V system supply)	21 mA
Data width	2 x 16-bit data
Isolation	300 VAC system/field
Ambient temperature (operation)	-40 ... +70 °C
Dimensions W x H x D	(24 x 100 x 67.8) mm
Explosion protection	
Safety-relevant data (circuit)	$U_o = 26.8 \text{ V}$; $I_o = 56.4 \text{ mA}$; $P_o = 378 \text{ mW}$; linear characteristic curve
Reactances Ex ia IIC	$L_o = 8.2 \text{ mH}$; $C_o = 0.092 \mu\text{F}$
Reactances Ex ia IIB	$L_o = 46 \text{ mH}$; $C_o = 0.72 \mu\text{F}$
Reactances Ex ia IIA	$L_o = 76 \text{ mH}$; $C_o = 2.37 \mu\text{F}$
Reactances Ex ia I	$L_o = 100 \text{ mH}$; $C_o = 3.85 \mu\text{F}$
Reactances (note)	Reactances without accounting for the concurrence of capacitance (C_o) and inductance (L_o)
Ex standard	EN/IEC 60079-0, -7, -11
Approvals	CE; Marine; OrdLoc/HazLoc; ATEX/IECEX
Marking	ATEX/IECEX: II 3 (1) G Ex ec [ia Ga] IIC T4 Gc; II (1) D [Ex ia Da] IIIC; I (M1) [Ex ia Ma] I
For data sheet and additional information, see:	wago.com/750-585/040-000

Intrinsically safe modules (Ex i) ► Counter



750-633/040-000

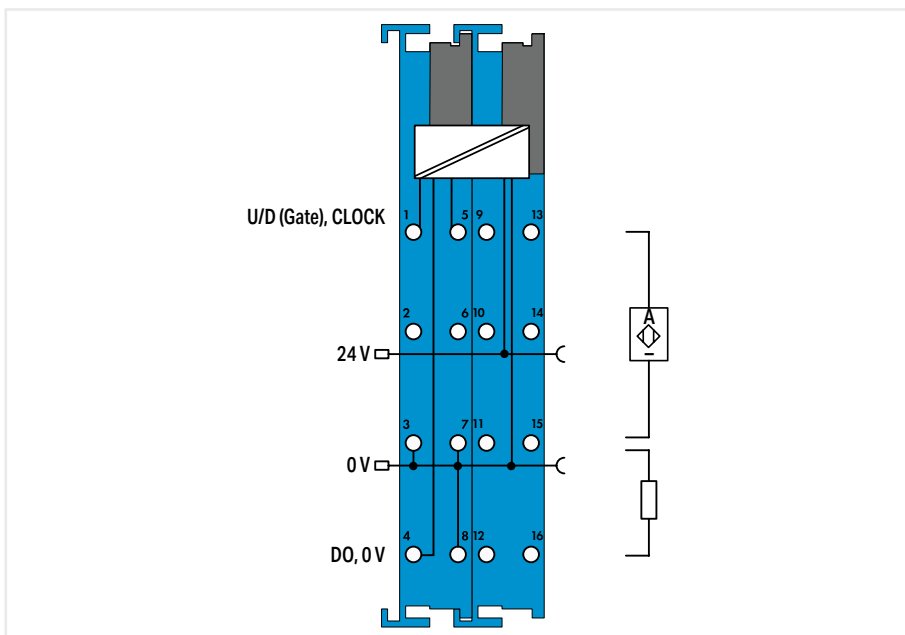

Item description	Up/Down Counter; Intrinsically safe
Version	extreme
Item no.	750-633/040-000
Order Text	Up/Down Counter; Ex i; XTR
Technical data	
Number of counters	1
Number of digital outputs	1
Sensor supply U_v	8.2 V
Switching frequency	20 Hz ... 50 kHz
Counter depth	32 bits
Output voltage	24 VDC
Input filter	10 μ s
Input resistance (max.)	1000 Ω
Open-circuit voltage	8.2 V
Supply voltage (field)	24 VDC; (Ex i XTR power supply: $U_o = \text{max. } 26.8 \text{ V}$); via power jumper contacts (power supply via blade contact; transmission via spring contact)
Current consumption, field supply (module with no external load)	31 mA
Current consumption (5 V system supply)	25 mA
Data width	1 x 32-bit data, 1 x 8-bit status/diagnostics
Isolation	300 VAC system/field
Ambient temperature (operation)	-40 ... +70 $^{\circ}\text{C}$
Dimensions W x H x D	(24 x 100 x 67.8) mm
Explosion protection	
Safety data (input)	$U_o = 12 \text{ V}$; $I_o = 13.3 \text{ mA}$; $P_o = 40.4 \text{ mW}$; linear characteristic curve
Reactances of Ex ia IIC inputs	$L_o = 100 \text{ mH}$; $C_o = 1.41 \mu\text{F}$
Reactances of Ex ia IIB inputs	$L_o = 100 \text{ mH}$; $C_o = 9 \mu\text{F}$
Reactances of Ex ia IIA inputs	$L_o = 100 \text{ mH}$; $C_o = 36 \mu\text{F}$
Reactances of Ex ia I inputs	$L_o = 100 \text{ mH}$; $C_o = 35 \mu\text{F}$
Safety data (output)	$U_o = 26.8 \text{ V}$; $I_o = 96.69 \text{ mA}$; $P_o = 674.83 \text{ mW}$; linear characteristic curve
Reactances of Ex ia IIC output	$L_o = 1.3 \text{ mH}$; $C_o = 0.091 \mu\text{F}$
Reactances of Ex ia IIB output	$L_o = 13 \text{ mH}$; $C_o = 0.719 \mu\text{F}$
Reactances of Ex ia IIA output	$L_o = 23 \text{ mH}$; $C_o = 2.369 \mu\text{F}$
Reactances of Ex ia I output	$L_o = 33 \text{ mH}$; $C_o = 3.849 \mu\text{F}$
Reactances (note)	Reactances without accounting for the concurrence of capacitance (C_o) and inductance (L_o)
Ex standard	EN/IEC 60079-0, -7, -11
Approvals	CE; Marine; OrdLoc/HazLoc; ATEX/IECEx
Marking	ATEX/IECEx: II 3 (1) G Ex ec [ia Ga] IIC T4 Gc; II (1) D [Ex ia Da] IIIC; I (M1) [Ex ia Ma] I
For data sheet and additional information, see:	wago.com/750-633/040-000

IP67



I/O System Field

I/O System – 750 and 753 Series

- Highly versatile
- More than 500 modules available
- Functional safety
- Ex i

◀ Section 7

I/O System – 750 XTR Series

- For demanding applications in which the following are critical:
- Extreme temperature resistance
 - Immunity to electromagnetic interference and impulse voltages
 - Vibration and shock resistance





◀ Section 8

I/O System Field

- Automate and Network Modular Machines for the Future
- Ethernet-based fieldbus standards (EtherCAT®, EtherNet/IP™, PROFINET)
 - Integrated Bluetooth® interface (Android/iOS App), OPC UA Server, Webservice
 - IO-Link Master and Devices

I/O System Field Contents

	Page
General Product Information	550
Functional Variants	551
Interfaces and Types	552
Item Number Key	553
Standards and Rated Conditions	553
Approvals	553
Configuration Guide	554

	PROFINET	EtherCAT®	EtherNet/IP™	IO-Link Master	IO-Link Devices	Description	Item No.		
Fieldbus Modules 	x					16-Channel Digital Input; 24 VDC; 8 x M12 Connector	765-1101/100-000	556	
		x					765-1201/100-000		
			x				765-1501/100-000		
		x					16-Channel Digital Output; 24 VDC; 8 x M12 Connector	765-1103/100-000	557
			x			765-1203/100-000			
						765-1503/100-000			
		x					16-Channel Digital Input/Output; 24 VDC; 8 x M12 Connector	765-1102/100-000	558
			x			765-1202/100-000			
						765-1502/100-000			
		x					8-Channel Digital Input/Output; 24 VDC; 4 x M12 Connector	765-1104/100-000	559
			x			765-1204/100-000			
						765-1504/100-000			
	x			8-Channel Digital Input/Output; 24 VDC; 8 x M8 Connector	765-1105/100-000	560			
		x	765-1205/100-000						
			765-1505/100-000						
IO-Link Masters 	x			Class A	8-Port IO-Link Master; 24 VDC 2.0 A; 8 x M12 Connector	765-4101/100-000	562		
		x				765-4201/100-000			
			x	Class B		765-4501/100-000			
	x					765-4102/100-000	563		
		x		765-4202/100-000					
			x	765-4502/100-000					
		x		Class A	4-Port IO-Link Master; 24 VDC 2.0 A; 4 x M12 Connector	765-4103/100-000	564		
			x			765-4203/100-000			
	x			Class B		765-4503/100-000	565		
		x				765-4104/100-000			
		x	765-4204/100-000						
			765-4504/100-000						
IO-Link Hubs 				Class A	8-Channel Digital Input/Output; 24 VDC 2.0 A; 4 x M12 Connector	765-1701/200-000	566		
						Class B	765-1704/200-000	567	
				Class A	8-Channel Digital Input/Output; 24 VDC 2.0 A; 8 x M8 Connector	765-1702/200-000	568		
						Class B	765-1705/200-000	569	
				Class A	16-Channel Digital Input/Output; 24 VDC 2.0 A; 8 x M12 Connector	765-1703/200-000	570		
						Class B	765-1706/200-000	571	
IO-Link Converter 				Class A	1-Channel Analog Input; IO-Link Converter; 4 ... 20 mA	765-2701/200-000	572		
				Class A/B	2-Channel Analog Input; IO-Link Converter; 0 ... 10 V	765-2702/200-000	573		
				Class A/B	2-Channel Analog Output; IO-Link Converter; 4 ... 20 mA	765-2703/200-000	574		
				Class A/B	2-Channel Analog Output; IO-Link Converter; 0 ... 10 V	765-2704/200-000	575		
	Accessories Power Cable; L-Coded; 5-Pole ETHERNET/PROFINET Cable; D-Coded; 4-Pole Pre-Assembled Connectors; 5-Pole; IDC Technology Mounting Clip						576		

I/O System Field

General Product Information

Automate and Network Modular Machines for the Future

High performance, designed for time-sensitive networking (TSN) and unshakeable even in the harshest environmental conditions: The WAGO I/O System Field for cabinet-free automation combines an impressive variety of functions with robust IP67 housings.

Extended Network Connectivity

Modern, decentralized production facilities require automation solutions that ensure the highest level of connectivity, while providing maximum performance outside of the control cabinet.

WAGO developed its upgradable I/O System Field with IP67 protection to meet these needs today and tomorrow: It combines fast ETHERNET-based fieldbuses (e.g., PROFINET), technologies such as OPC UA, *Bluetooth*® and Webserver, and MQTT for cloud connectivity.

Functionality and Aesthetics in One System

The IP67 I/O System Field offers no-compromise protection with pressure cast zinc housings for extremely harsh environments, or robust yet lightweight plastic housings for mobile applications. The modules operate reliably at temperatures from -25 to +70°C (-13 ... +158°F) and, thanks to internal shielding, are immune to electromagnetic interference. Slim housing variants and lateral mounting options open up more space.



Industrial Ethernet and PROFINET on the field level provide the basis for digitalization with WAGO I/O System Field, which supports Ethernet-based standards (EtherNet/IP™ and EtherCAT®) and is #made for TSN (Time-Sensitive Networking).



WAGO I/O System Field supports MQTT as an open message protocol for data transmission.



The system is equipped with an OPC UA server, allowing OPC UA clients to access the widest range of device data (e.g., parameter data, status information, identification/diagnostics data, containers).



Fieldbus modules equipped with IO-Link masters and IO-Link hubs as devices facilitate effective, versatile connection of intelligent sensors/actuators to the automation system.



An app for direct access to a WAGO Field Device via DMC (Data Matrix Code) identification and BLE (*Bluetooth*® Low Energy) communication is available for wireless access with a mobile device.



An integrated Webserver enables HTTP and HTTPS communication. With this capability, a wide range of system information can be accessed using standard browsers.

Integrated Load Management

Innovative load management ensures that the system's power is fully utilized via supply and output current load management. Current and voltage can be recorded and evaluated for each channel. Overload limits can be set for individual channels. As a result, errors can be detected faster and more clearly differentiated in the event of faults – it is also easier to predict errors, which is essential for future-oriented trends such as predictive maintenance.

All-in-One Solution via IO-Link

In combination with IO-Link, the I/O System Field fully demonstrates its strengths as a flexible "IO distributor" for both data collection and distribution. The prominent communication standard enables seamless data flow from the control to the sensor and actuator level. This considerably simplifies configuration and cabling. Furthermore, completely new possibilities arise for diagnostics, parameterization and device identification.

Advantages:

- Platform-independent data exchange through OPC UA
- System information provided via MQTT
- Fast on-site access to data through *Bluetooth*®
- Status information of the system via integrated Webserver
- Ready for future TSN implementation
- Fully encapsulated IP67 metal housings for extreme environments
- Non-encapsulated, lightweight IP67 plastic housings for mobile applications
- WAGO standard marking (WMB Inline markers and marking strips)

I/O System Field Functional Variants



Fieldbus Module and IO-Link Master as PROFINET, EtherCAT® or EtherNet/IP™ Slave

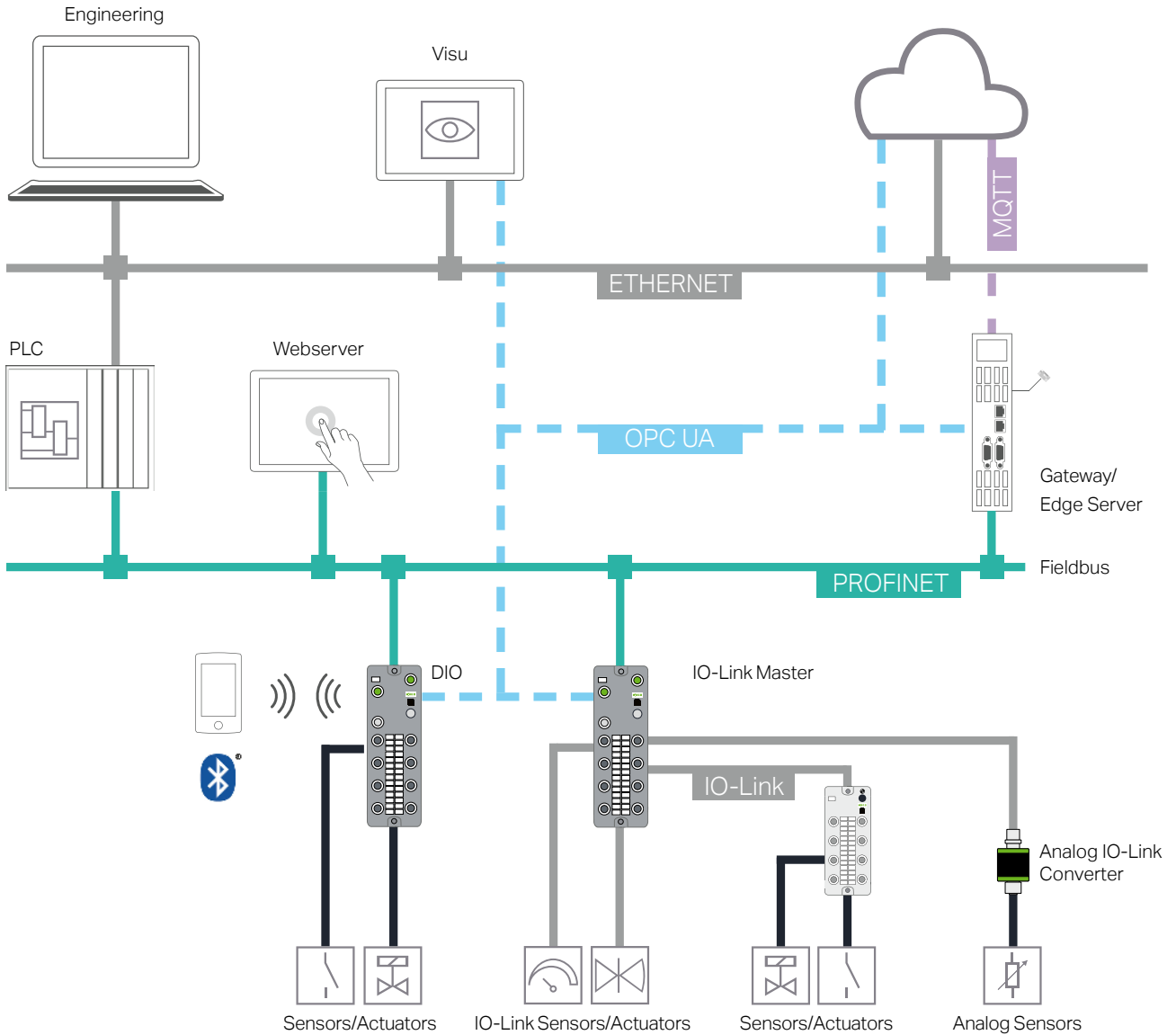

9

I/O System Field Interfaces and Types

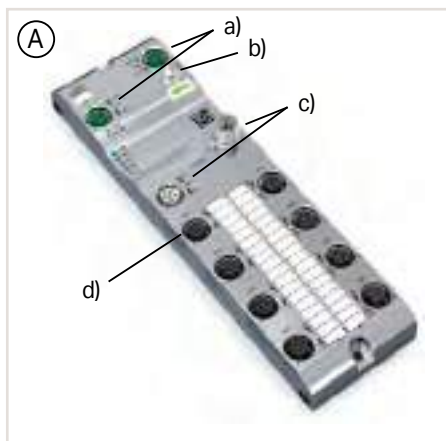

Fieldbus Module

- Fieldbus: 2 x D-coded M12; 5-pole (a)
- *Bluetooth*[®] (b)
- Supply: L-coded M12; 5-pole (c)

Housing Design (A): 16 DI, 16 DO or 16 DIO

- Inputs/Outputs: A-coded M12; 5-pole (d)
- W x H x D (mm): 60 x 30 x 210

Housing Design (B): 8 DIO

- Inputs/Outputs: A-coded M12; 5-pole (d) or M8; 3-pole (e)
- W x H x D (mm): 35 x 30 x 210

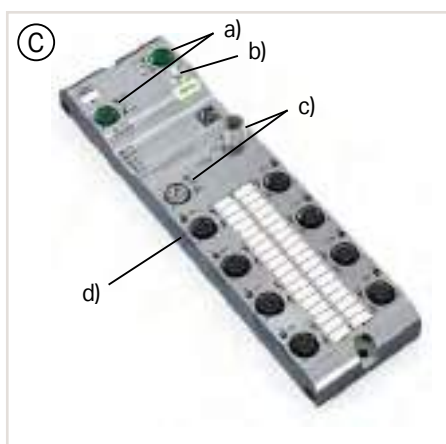
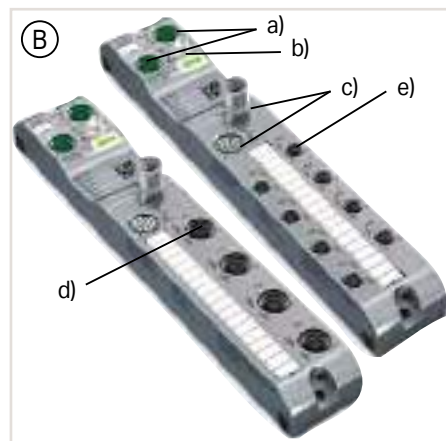

IO-Link Master

- Fieldbus: 2 x D-coded M12; 5-pole (a)
- *Bluetooth*[®] (b)
- Supply: L-coded M12; 5-pole (c)
- IO-Link Ports: A-coded M12; 5-pole (d)

Housing Design (C): 8 IO-Link ports, class A or B

- W x H x D (mm): 60 x 30 x 210

Housing Design (D): 4 IO-Link ports, class A or B

- W x H x D (mm): 35 x 30 x 210

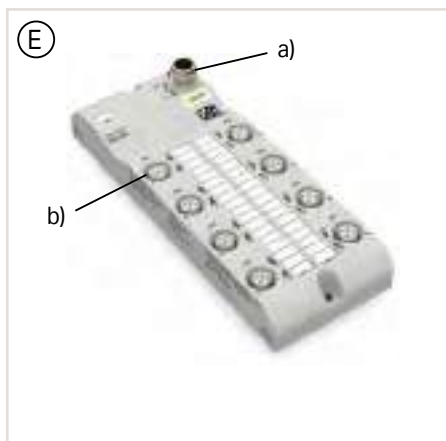
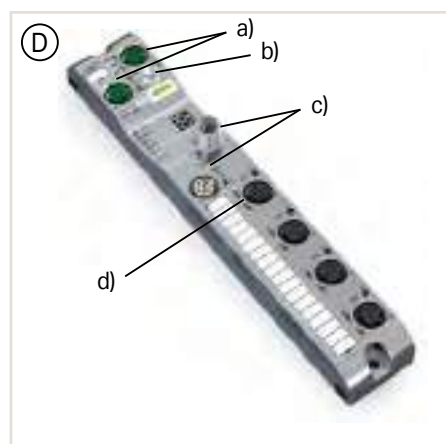

IO-Link Hub

- IO-Link Hub: A-coded M12; 5-pole (a)

Housing Design (E): 16 DIO

- Inputs/Outputs: A-coded M12; 5-pole (b)
- W x H x D (mm): 60 x 30 x 158.5

Housing Design (F): 8 DIO

- Inputs/Outputs: A-coded M12; 5-pole (b) or M8; 3-pole (c)
- W x H x D (mm): 35 x 30 x 158.5

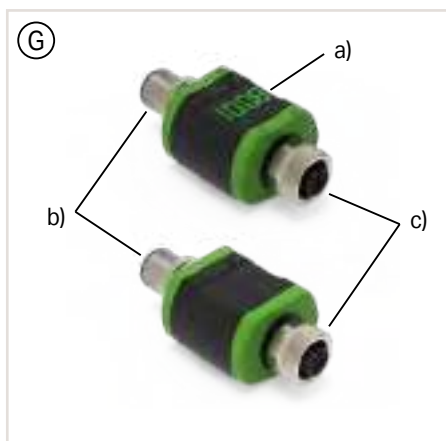
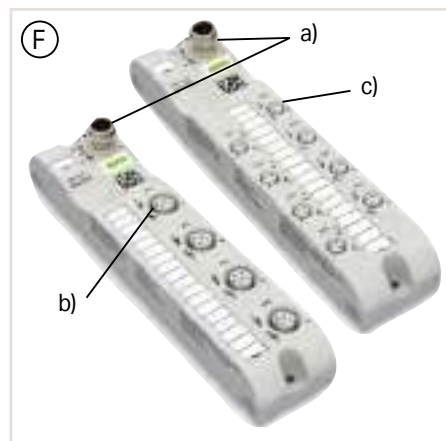

Analog IO-Link Converter

Housing Design (G)

- configurable via IO-Link; with display (a) also directly on the device
- IO-Link side: M12-A plug; 4-pole (b)
- Sensor/Actuator side: M12-A socket; 5-pole (c)

I/O System Field Item Number Key

Explanation of an item number key's components

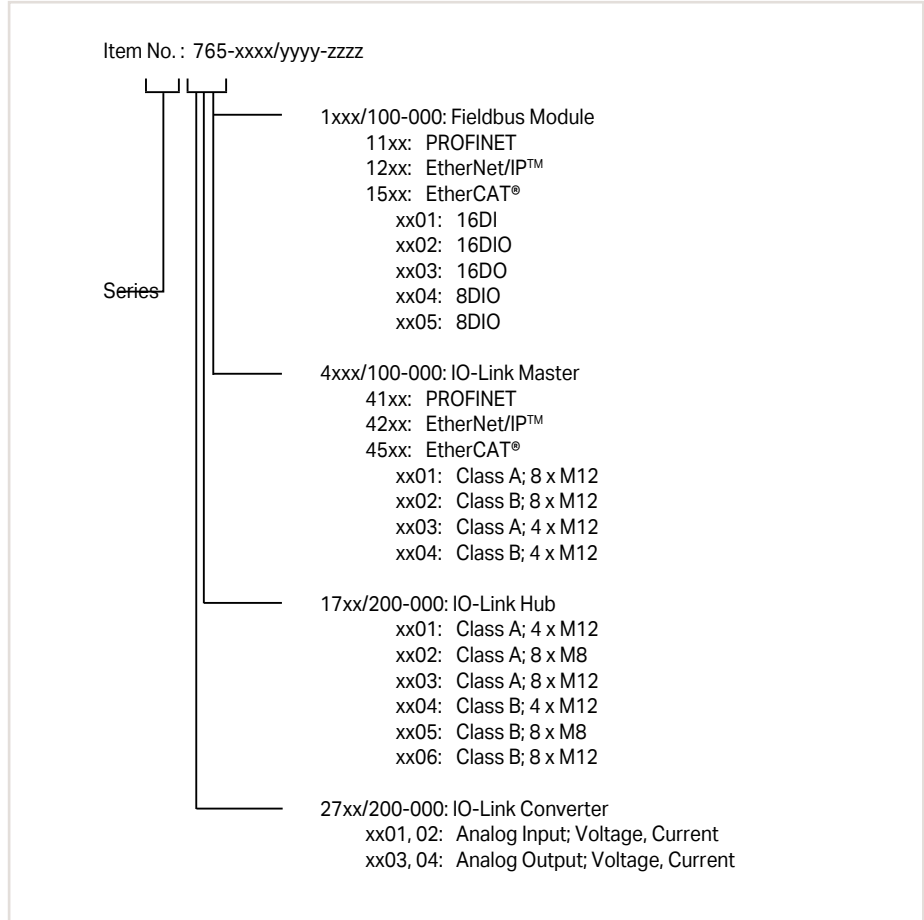

9

Standards and Rated Conditions

General Specifications	
Supply voltage (system)	24 VDC (-25 ... +30 %)
Surrounding air temperature (operation)	-25 ... +70 °C
Surrounding air temperature (storage)	-40 ... +80 °C
Maximum temperature change	3 K/min
Relative humidity (operation)	5 ... 95 % (with condensation)
Pollution degree	3 (EN 60664-1)
Operating altitude	0 ... 2000 m / 0 ... 6562 ft
Overvoltage category	II (EN 60664-1)
Protection type	IP67 (EN 60529)
Protection class	III (EN 61140)
Vibration resistance	5g (IEC 60068-2-6)
Shock resistance	50g (IEC 60068-2-27)
EMC immunity to interference	Per EN 61000-6-2
EMC emission of interference	Per EN 61000-6-4
Mounting type	Screw mount, 2xM4 (front and side)
Connection technology	M8 and M12 connectors
Housing material	Metal, plastic (PA, PBT)

For approvals overview (item comparison), see Section 14 (Technical Section) or visit www.wago.com.



FCC/ISED

I/O System Field Configuration Guide

IP67

756-1203/..., 756-1204/...

756-1203/..., 756-1204/...



756-3505/...,
756-3506/...

756-3505/...,
756-3506/...

765-4102/100-000
IO-Link Master

765-4104/100-000
IO-Link Master

756-5401/0050-XXXX

756-5404/0050-XXXX

756-5401/0050-XXXX

756-5404/0050-XXXX

756-5401/0050-XXXX

756-5404/0050-XXXX

765-1706/200-000
IO-Link Hub

765-1704/200-000
IO-Link Hub

756-5311/0040-xxxx
756-5312/0040-xxxx

756-5111/0030-xxxx
756-5112/0030-xxxx

756-5111/0030-xxxx
756-5112/0030-xxxx



IO-Link Sensors/Actuators

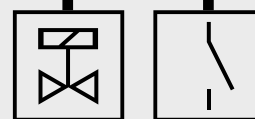

Sensors/Actuators

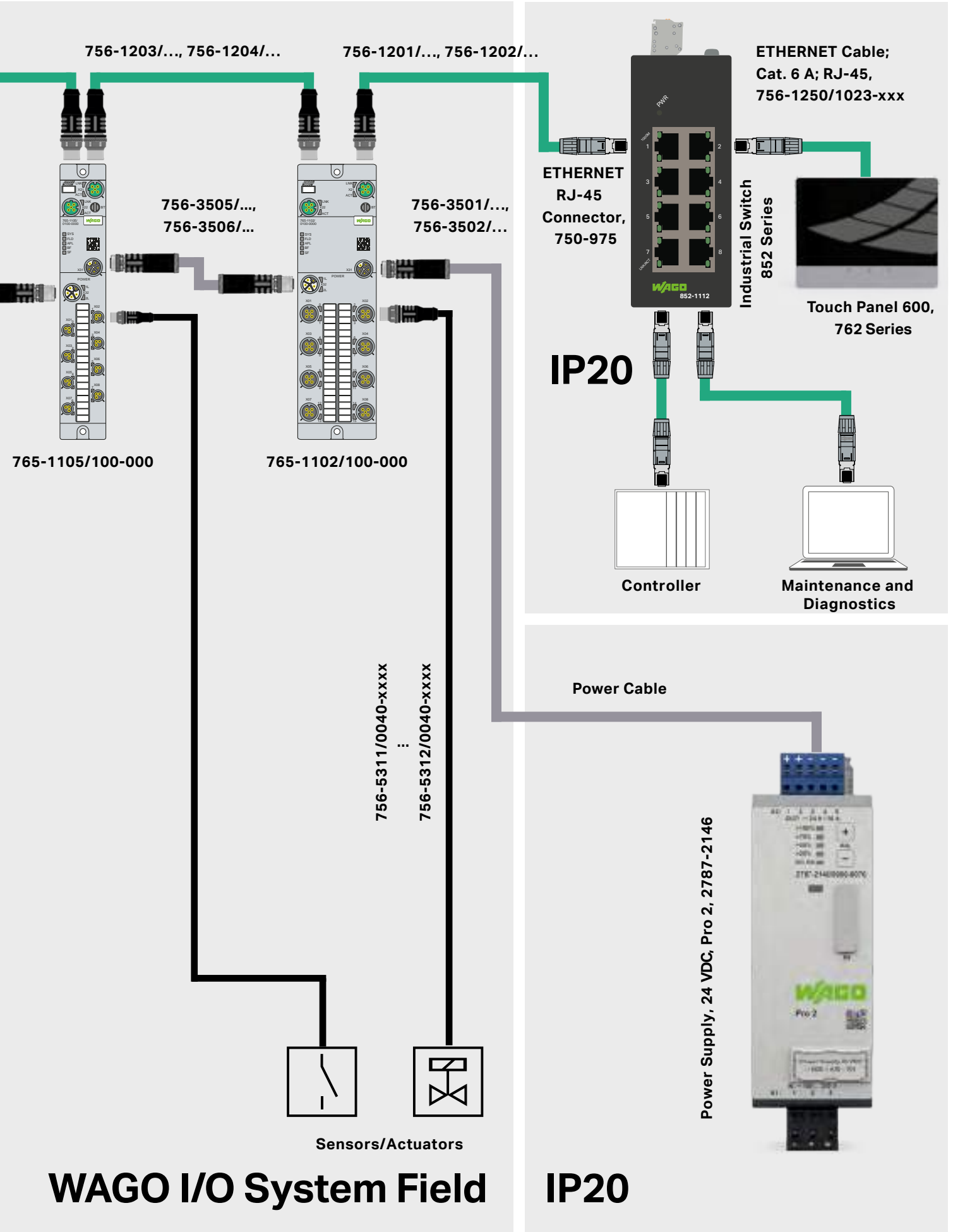

Fieldbus module ► 16-Channel Digital Input; I/O System Field; 24 VDC; 8 x M12 connector



765-1101/100-000

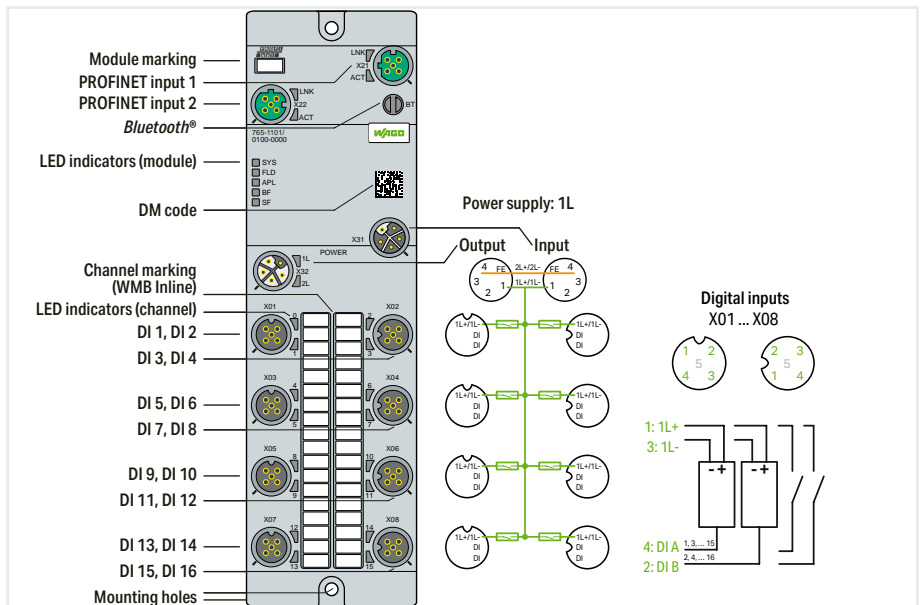

Item description	16-Channel Digital Input; I/O System Field; 24 VDC; 8 x M12 connector		
Version	PROFINET slave	EtherCAT® slave	EtherNet/IP™ slave
Item no.	765-1101/100-000	765-1201/100-000	765-1501/100-000
Order Text	16DI FLD PN DC 24V	16DI FLD EC DC 24V	16DI FLD EI DC 24V

Technical data			
Fieldbus			
Communication	PROFINET; PROFINET IO device; 2-port switch, LLDP, MRP, SNMP	EtherCAT®; AoE, EoE, FoE	EtherNet/IP™; BOOTP, DHCP, DLR
Connection technology: communication/fieldbus	2 x D-coded M12; 4-pole		
Interface standard	10BASE-T/100BASE-TX; potential-free		
Autonegotiation; autocrossover	Yes		
Device functions	Input filter; Temperature		
Parameter	Undervoltage; overcurrent; overload; overtemperature		
Diagnostics	Bluetooth®; OPC UA server		
Device functions	Android/iOS app; Web server		
Visualization			
Digital inputs/outputs			
Number of digital inputs	16		
Connection technology: inputs/outputs	8 x A-coded M12; 5-pole		
Signal type (voltage)	24 VDC		
Sensor current (per channel) max.	2 A		
Input characteristic	high-side switching		
Input filter	0.2 ... 20 ms		
Input characteristic	Type 3, per IEC 61131-2		
Supply (module)			
Connection technology: supply	2 x L-coded M12; 5-pole		
Supply voltage	24 VDC (18 ... 31.2 V); 1L/2L		
Current consumption (max.)	16000 mA		
Current consumption (note)	per supply line; overload- and short-circuit-protected		
Reverse voltage protection	Yes		
Ambient temperature (operation)	-25 ... +70 °C		
Approvals	CE; FCC/ISED		
Approvals (pending)	OrdLoc		

For data sheet and additional information, see: wago.com/765-1101/100-000 | wago.com/765-1201/100-000 | wago.com/765-1501/100-000

Accessories	Item no.	Item no.	Item no.
Torque wrench M8 and M12; Assembly kit	206-701	206-701	206-701
M12 protective cap; for unused sockets	756-8102	756-8102	756-8102
M12 protective cap; for unused plugs	756-8103	756-8103	756-8103
Marking strips; for Smart Printer; on reel; not stretchable; plain; snap-on type; white	2009-110	2009-110	2009-110
WMB-Inline; for Smart Printer; 1500 pieces on roll; stretchable 5 - 5.2 mm; plain; snap-on type; white	2009-115	2009-115	2009-115

9

Fieldbus module



765-1103/100-000

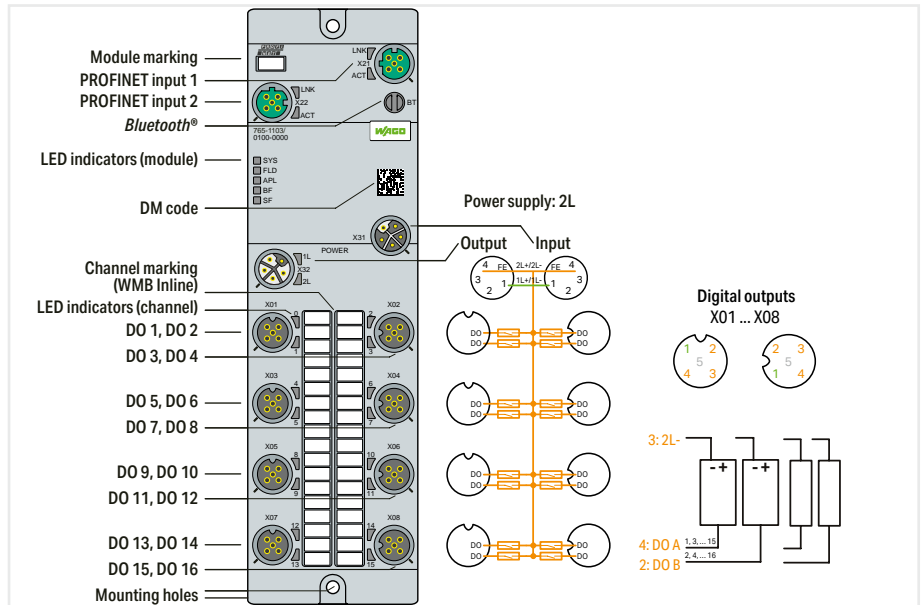

Item description	16-Channel Digital Output; I/O System Field; 24 VDC; 8 x M12 connector		
Version	PROFINET slave	EtherCAT® slave	EtherNet/IP™ slave
Item no.	765-1103/100-000	765-1203/100-000	765-1503/100-000
Order Text	16DO FLD PN DC 24V	16DO FLD EC DC 24V	16DO FLD EI DC 24V

Technical data			
Fieldbus			
Communication	PROFINET; PROFINET IO device; 2-port switch, LLDP, MRP, SNMP	EtherCAT®; AoE, EoE, FoE	EtherNet/IP™; BOOTP, DHCP, DLR
Connection technology: communication/fieldbus	2 x D-coded M12; 4-pole		
Interface standard	10BASE-T/100BASE-TX; potential-free		
Autonegotiation; autocrossover	Yes		
Device functions	Output current; Temperature		
Parameter	Undervoltage; overcurrent; overload; overtemperature		
Diagnostics	Bluetooth®; OPC UA server		
Device functions	Android/iOS app; Web server		
Visualization			
Digital inputs/outputs			
Number of digital outputs	16		
Connection technology: inputs/outputs	8 x A-coded M12; 5-pole		
Signal type (voltage)	24 VDC		
Output current (per channel)	2 A (typ.) for DO		
Supply current per port	2L: 4 A (max.)	1L/2L: 4 A (max.)	
Supply (module)			
Connection technology: supply	2 x L-coded M12; 5-pole		
Supply voltage	24 VDC (18 ... 31.2 V); 1L/2L		
Current consumption (max.)	16000 mA		
Current consumption (note)	per supply line; overload- and short-circuit-protected		
Reverse voltage protection	Yes		
Ambient temperature (operation)	-25 ... +70 °C		
Approvals	CE; FCC/ISED		
Approvals (pending)	OrdLoc		
For data sheet and additional information, see:	wago.com/765-1103/100-000	wago.com/765-1203/100-000	wago.com/765-1503/100-000
Accessories	Item no.	Item no.	Item no.
Torque wrench M8 and M12; Assembly kit	206-701	206-701	206-701
M12 protective cap; for unused sockets	756-8102	756-8102	756-8102
M12 protective cap; for unused plugs	756-8103	756-8103	756-8103
Marking strips; for Smart Printer; on reel; not stretchable; plain; snap-on type; white	2009-110	2009-110	2009-110
WMB-Inline; for Smart Printer; 1500 pieces on roll; stretchable 5 - 5.2 mm; plain; snap-on type; white	2009-115	2009-115	2009-115

Fieldbus module ► 16-Channel Digital Input/Output; I/O System Field; 24 VDC; 8 x M12 connector



765-1102/100-000

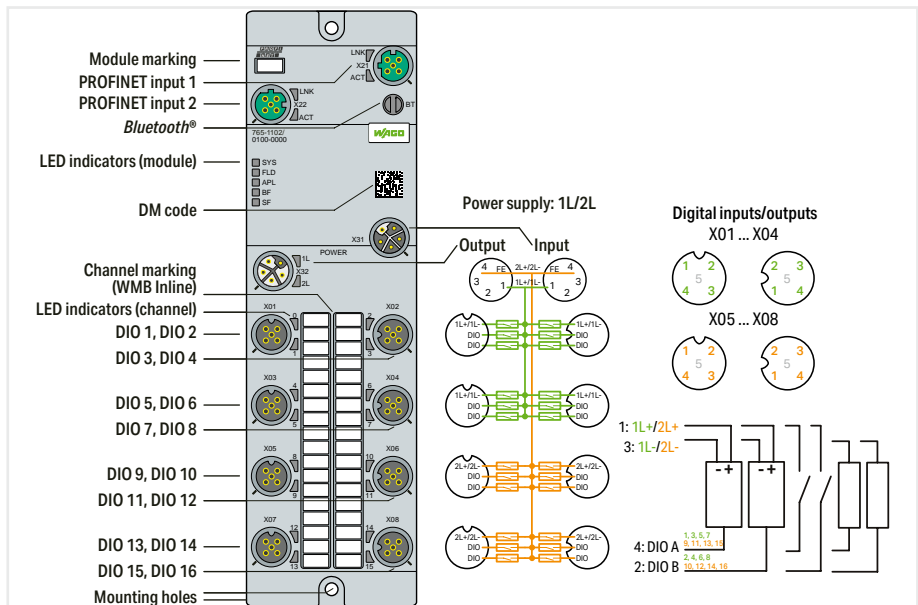

Item description	16-Channel Digital Input/Output; I/O System Field; 24 VDC; 8 x M12 connector		
Version	PROFINET slave	EtherCAT® slave	EtherNet/IP™ slave
Item no.	765-1102/100-000	765-1202/100-000	765-1502/100-000
Order Text	16DIO FLD PN DC 24V	16DIO FLD EC DC 24V	16DIO FLD EI DC 24V

Technical data			
Fieldbus			
Communication	PROFINET; PROFINET IO device; 2-port switch, LLDP, MRP, SNMP	EtherCAT®; AoE, EoE, FoE	EtherNet/IP™; BOOTP, DHCP, DLR
Connection technology: communication/fieldbus	2 x D-coded M12; 4-pole		
Interface standard	10BASE-T/100BASE-TX; potential-free		
Autonegotiation; autocrossover	Yes		
Device functions	Input filter; Output current; Temperature		
Parameter	Undervoltage; overcurrent; overload; overtemperature		
Diagnostics	Bluetooth®; OPC UA server		
Device functions	Android/iOS app; Web server		
Visualization			
Digital inputs/outputs			
Number of digital inputs	16		
Number of digital outputs	16		
Connection technology: inputs/outputs	8 x A-coded M12; 5-pole		
Signal type (voltage)	24 VDC		
Input characteristic	high-side switching		
Input filter	0.2 ... 20 ms		
Input characteristic	Type 3, per IEC 61131-2		
Output current (per channel)	2 A (typ.) for DO		
Supply current per port	1L/2L: 4 A (max.)		
Supply (module)			
Connection technology: supply	2 x L-coded M12; 5-pole		
Supply voltage	24 VDC (18 ... 31.2 V); 1L/2L		
Current consumption (max.)	16000 mA		
Current consumption (note)	per supply line; overload- and short-circuit-protected		
Reverse voltage protection	Yes		
Ambient temperature (operation)	-25 ... +70 °C		
Approvals	CE; FCC/ ISED		
Approvals (pending)	OrdLoc		
For data sheet and additional information, see:	wago.com/765-1102/100-000	wago.com/765-1202/100-000	wago.com/765-1502/100-000

Accessories	Item no.	Item no.	Item no.
Torque wrench M8 and M12; Assembly kit	206-701	206-701	206-701
M12 protective cap; for unused sockets	756-8102	756-8102	756-8102
M12 protective cap; for unused plugs	756-8103	756-8103	756-8103
Marking strips; for Smart Printer; on reel; not stretchable; plain; snap-on type; white	2009-110	2009-110	2009-110
WMB-Inline; for Smart Printer; 1500 pieces on roll; stretchable 5 - 5.2 mm; plain; snap-on type; white	2009-115	2009-115	2009-115

9

Fieldbus module ▶ 8-Channel Digital Input/Output; I/O System Field; 24 VDC; 4 x M12 connector



765-1104/100-000

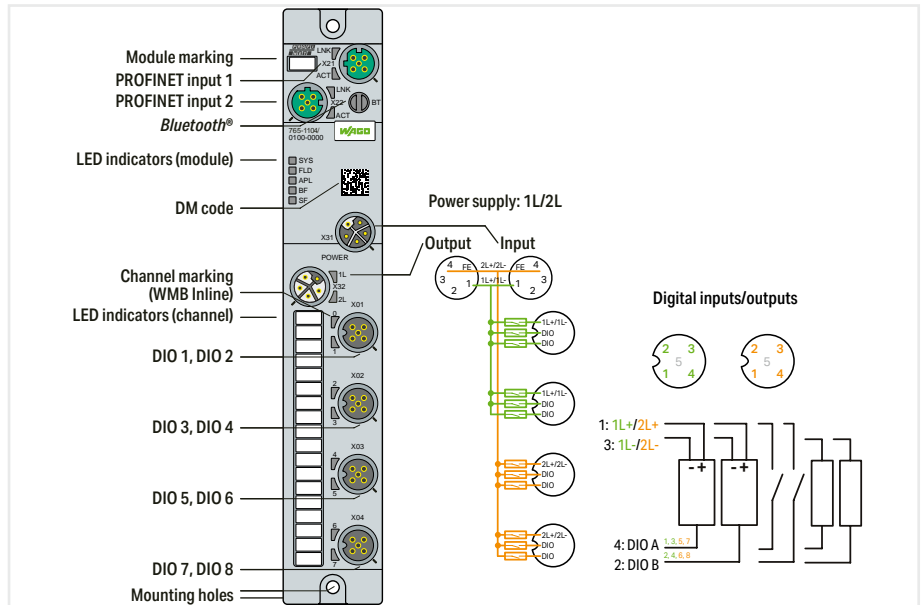

Item description	8-Channel Digital Input/Output; I/O System Field; 24 VDC; 4 x M12 connector		
Version	PROFINET slave	EtherCAT® slave	EtherNet/IP™ slave
Item no.	765-1104/100-000	765-1204/100-000	765-1504/100-000
Order Text	8DIO FLD PN DC 24V	8DIO FLD EC DC 24V	8DIO FLD EI DC 24V

Technical data			
Fieldbus			
Communication	PROFINET; PROFINET IO device; 2-port switch, LLD, MRP, SNMP	EtherCAT®; AoE, EoE, FoE	EtherNet/IP™; BOOTP, DHCP, DLR
Connection technology: communication/fieldbus	2 x D-coded M12; 4-pole		
Interface standard	10BASE-T/100BASE-TX; potential-free		
Autonegotiation; autocrossover	Yes		
Device functions	Input filter; Output current; Temperature		
Parameter	Undervoltage; overcurrent; overload; overtemperature		
Diagnostics	Bluetooth®; OPC UA server		
Device functions	Android/iOS app; Web server		
Visualization			
Digital inputs/outputs			
Number of digital inputs	8		
Number of digital outputs	8		
Connection technology: inputs/outputs	4 x A-coded M12; 5-pole		
Signal type (voltage)	24 VDC		
Input characteristic	high-side switching		
Input filter	0.2 ... 20 ms		
Input characteristic	Type 3, per IEC 61131-2		
Output current (per channel)	2 A (typ.) for DO		
Supply current per port	1L/2L: 4 A (max.)		
Supply (module)			
Connection technology: supply	2 x L-coded M12; 5-pole		
Supply voltage	24 VDC (18 ... 31.2 V); 1L/2L		
Current consumption (max.)	16000 mA		
Current consumption (note)	per supply line; overload- and short-circuit-protected		
Reverse voltage protection	Yes		
Ambient temperature (operation)	-25 ... +70 °C		
Approvals	CE; FCC/ ISED		
Approvals (pending)	®- OrdLoc		
For data sheet and additional information, see:	wago.com/765-1104/100-000	wago.com/765-1204/100-000	wago.com/765-1504/100-000

Accessories	Item no.	Item no.	Item no.
Torque wrench M8 and M12; Assembly kit	206-701	206-701	206-701
M12 protective cap; for unused sockets	756-8102	756-8102	756-8102
M12 protective cap; for unused plugs	756-8103	756-8103	756-8103
Marking strips; for Smart Printer; on reel; not stretchable; plain; snap-on type; white	2009-110	2009-110	2009-110
WMB-Inline; for Smart Printer; 1500 pieces on roll; stretchable 5 - 5.2 mm; plain; snap-on type; white	2009-115	2009-115	2009-115

Fieldbus module ► 8-Channel Digital Input/Output; I/O System Field; 24 VDC; 8 x M8 connector



765-1105/100-000

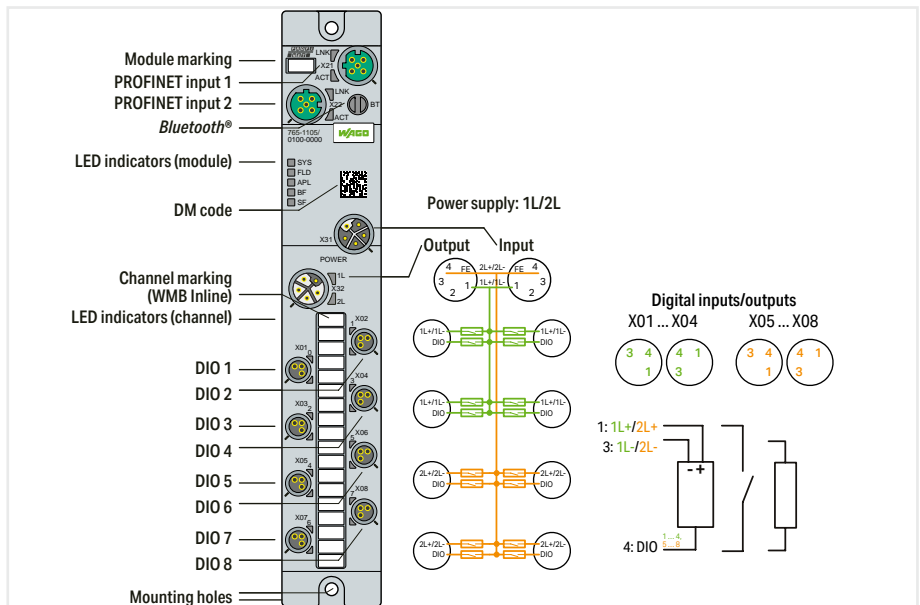

Item description	8-Channel Digital Input/Output; I/O System Field; 24 VDC; 8 x M8 connector		
Version	PROFINET slave	EtherCAT® slave	EtherNet/IP™ slave
Item no.	765-1105/100-000	765-1205/100-000	765-1505/100-000
Order Text	8DIO FLD PN DC 24V	8DIO FLD EC DC 24V	8DIO FLD EI DC 24V

Technical data			
Fieldbus			
Communication	PROFINET; PROFINET IO device; 2-port switch, LLDAP, MRP, SNMP	EtherCAT®; AoE, EoE, FoE	EtherNet/IP™; BOOTP, DHCP, DLR
Connection technology: communication/fieldbus	2 x D-coded M12; 4-pole		
Interface standard	10BASE-T/100BASE-TX; potential-free		
Autonegotiation; autocrossover	Yes		
Device functions	Input filter; Output current; Temperature		
Parameter	Undervoltage; overcurrent; overload; overtemperature		
Diagnostics	Bluetooth®; OPC UA server		
Device functions	Android/iOS app; Web server		
Visualization			
Digital inputs/outputs			
Number of digital inputs	8		
Number of digital outputs	8		
Connection technology: inputs/outputs	8 x M8; 3-pole		
Signal type (voltage)	24 VDC		
Input characteristic	high-side switching		
Input filter	0.2 ... 20 ms		
Input characteristic	Type 3, per IEC 61131-2		
Output current (per channel)	2 A (typ.) for DO		
Supply current per port	1L/2L: 4 A (max.)		
Supply (module)			
Connection technology: supply	2 x L-coded M12; 5-pole		
Supply voltage	24 VDC (18 ... 31.2 V); 1L/2L		
Current consumption (max.)	16000 mA		
Current consumption (note)	per supply line; overload- and short-circuit-protected		
Reverse voltage protection	Yes		
Ambient temperature (operation)	-25 ... +70 °C		
Approvals	CE; FCC/ ISED		
Approvals (pending)	Ⓢ- OrdLoc		
For data sheet and additional information, see:	wago.com/765-1105/100-000	wago.com/765-1205/100-000	wago.com/765-1505/100-000

Accessories	Item no.	Item no.	Item no.
Torque wrench M8 and M12; Assembly kit	206-701	206-701	206-701
M8 protective cap; for unused sockets	756-8101	756-8101	756-8101
M12 protective cap; for unused sockets	756-8102	756-8102	756-8102
M12 protective cap; for unused plugs	756-8103	756-8103	756-8103
Marking strips; for Smart Printer; on reel; not stretchable; plain; snap-on type; white	2009-110	2009-110	2009-110
WMB-Inline; for Smart Printer; 1500 pieces on roll; stretchable 5 - 5.2 mm; plain; snap-on type; white	2009-115	2009-115	2009-115

9

9

IO-Link master ▶ 8-Port IO-Link Master Class A; I/O System Field; 24 VDC / 2.0 A; 8 x M12 Connector



765-4101/100-000

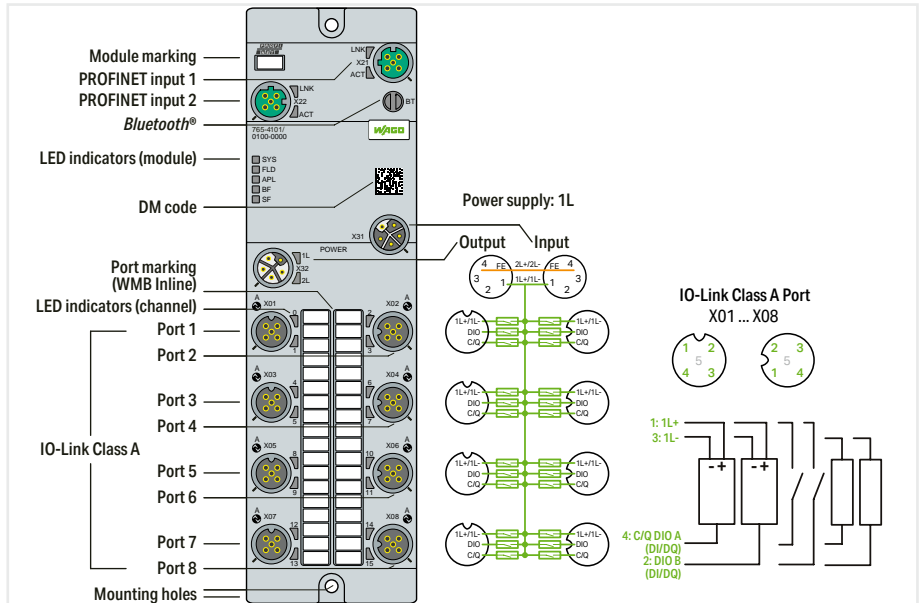

Item description	8-Port IO-Link Master Class A; I/O System Field; 24 VDC / 2.0 A; 8 x M12 Connector		
Version	PROFINET	EtherCAT®	EtherNet/IP™
Item no.	765-4101/100-000	765-4201/100-000	765-4501/100-000
Order Text	8PORT IOL-A FLD PN DC 24V 2.0A	8PORT IOL-A FLD EC DC 24V 2.0A	8PORT IOL-A FLD EI DC 24V 2.0A

Technical data			
Fieldbus			
Communication	PROFINET; PROFINET IO device; 2-port switch, LLDP, MRP, SNMP	EtherCAT®; AoE, EoE, FoE	EtherNet/IP™; BOOTP, DHCP, DLR
Connection technology: communication/fieldbus	2 x D-coded M12; 4-pole		
Interface standard	10BASE-T/100BASE-TX; potential-free		
Autonegotiation; autocrossover	Yes		
Device functions	Input filter; Output current; Temperature		
Parameter	Undervoltage; overcurrent; overload; overtemperature		
Diagnostics	Bluetooth®; OPC UA server		
Device functions	Android/iOS app; Web server		
Visualization			
IO-Link master			
IO-Link master classification	Class A; V1.1 specification		
Port mode	IO-Link: autoconfig, manual, tool-based; DI; DO		
Cycle time	400 µs (min.)		
Operating mode	IO-Link master, DI or DO (adjustable for pin 4 per port); DI or DO (adjustable for pin 2 per port)		
IO-Link ports			
Number of digital inputs	16		
Number of digital outputs	16		
Connection technology: inputs/outputs	8 x A-coded M12; 5-pole		
Signal type (voltage)	24 VDC		
Input characteristic	high-side switching		
Input filter	0.2 ... 20 ms		
Input characteristic	Type 3, per IEC 61131-2		
Output current (per channel)	2 A (typ.) for DO		
Supply current per port	1L: 1 A for IO-Link; 4 A (max.) for DIO		
Supply (module)			
Connection technology: supply	2 x L-coded M12; 5-pole		
Supply voltage	24 VDC (18 ... 31.2 V); 1L		
Current consumption (max.)	16000 mA		
Current consumption (note)	per supply line; overload- and short-circuit-protected		
Reverse voltage protection	Yes		
Ambient temperature (operation)	-25 ... +70 °C		
Approvals	CE; FCC/ISED		
Approvals (pending)	OrdLoc		

For data sheet and additional information, see: wago.com/765-4101/100-000 wago.com/765-4201/100-000 wago.com/765-4501/100-000

Accessories	Item no.	Item no.	Item no.
Torque wrench M8 and M12; Assembly kit	206-701	206-701	206-701
M12 protective cap; for unused sockets	756-8102	756-8102	756-8102
M12 protective cap; for unused plugs	756-8103	756-8103	756-8103
Marking strips; for Smart Printer; on reel; not stretchable	2009-110	2009-110	2009-110
WMB-Inline; for Smart Printer; 1500 pieces on roll; stretchable 5 - 5.2 mm; plain; snap-on type; white	2009-115	2009-115	2009-115

IO-Link master ▶ 8-Port IO-Link Master Class B; I/O System Field; 24 VDC / 2.0 A; 8 x M12 Connector



765-4102/100-000

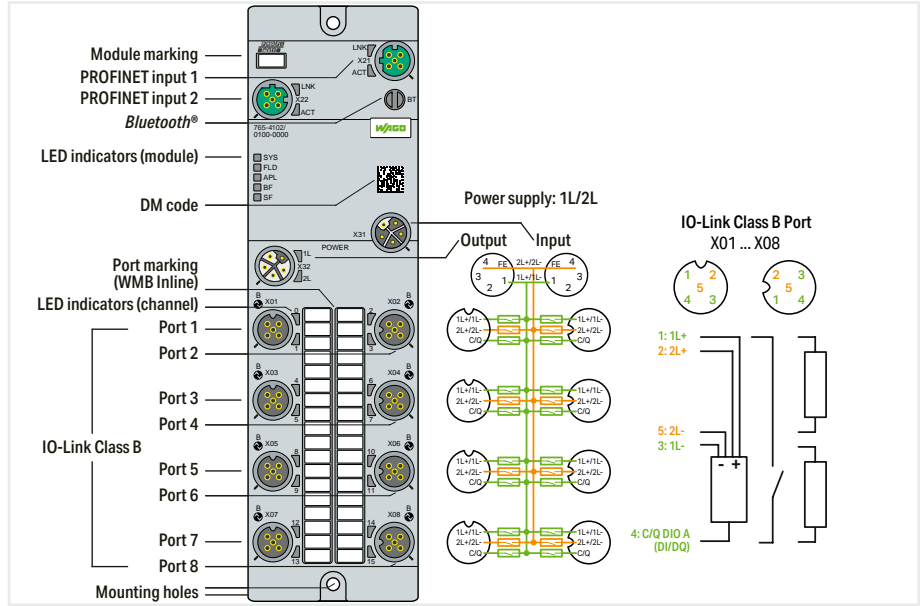

Item description	8-Port IO-Link Master Class B; I/O System Field; 24 VDC / 2.0 A; 8 x M12 Connector		
Version	PROFINET	EtherCAT®	EtherNet/IP™
Item no.	765-4102/100-000	765-4202/100-000	765-4502/100-000
Order Text	8PORT IOL-B FLD PN DC 24V 2.0A	8PORT IOL-B FLD EC DC 24V 2.0A	8PORT IOL-B FLD EI DC 24V 2.0A

Technical data			
Fieldbus			
Communication	PROFINET; PROFINET IO device; 2-port switch, LLD, MRP, SNMP	EtherCAT®; AoE, EoE, FoE	EtherNet/IP™; BOOTP, DHCP, DLR
Connection technology: communication/fieldbus	2 x D-coded M12; 4-pole		
Interface standard	10BASE-T/100BASE-TX; potential-free		
Autonegotiation; autocrossover	Yes		
Device functions	Input filter; Output current; Temperature		
Parameter	Undervoltage; overcurrent; overload; overtemperature		
Diagnostics	Bluetooth®; OPC UA server		
Device functions	Android/iOS app; Web server		
Visualization			
IO-Link master			
IO-Link master classification	Class B; V1.1 specification		
Port mode	IO-Link: autoconfig, manual, tool-based; DI; DO		
Cycle time	400 µs (min.)		
Operating mode	IO-Link master, DI or DO (adjustable for pin 4 per port); Supply voltage 2L (fixed for pin 2 per port)		
IO-Link ports			
Number of digital inputs	8		
Number of digital outputs	8		
Connection technology: inputs/outputs	8 x A-coded M12; 5-pole		
Signal type (voltage)	24 VDC		
Input characteristic	high-side switching		
Input filter	0.2 ... 20 ms		
Input characteristic	Type 3, per IEC 61131-2		
Output current (per channel)	2 A (typ.) for DO		
Supply current per port	1L (pin 1): 1 A for IO-Link; 4 A (max.) for DIO; 2L (pin 2): 4 A (max.)	1L (Pin 1): 1 A for IO-Link; 4 A (max.) for DIO; 2L (Pin 2): 4 A (max.)	
Supply (module)			
Connection technology: supply	2 x L-coded M12; 5-pole		
Supply voltage	24 VDC (18 ... 31.2 V); 1L/2L		
Current consumption (max.)	16000 mA		
Current consumption (note)	per supply line; overload- and short-circuit-protected		
Reverse voltage protection	Yes		
Ambient temperature (operation)	-25 ... +70 °C		
Approvals	CE; FCC / ISED		
Approvals (pending)	OrdLoc		

For data sheet and additional information, see: wago.com/765-4102/100-000 | wago.com/765-4202/100-000 | wago.com/765-4502/100-000

Accessories	Item no.	Item no.	Item no.
Torque wrench M8 and M12; Assembly kit	206-701	206-701	206-701
M12 protective cap; for unused sockets	756-8102	756-8102	756-8102
M12 protective cap; for unused plugs	756-8103	756-8103	756-8103
Marking strips; for Smart Printer; on reel; not stretchable	2009-110	2009-110	2009-110
WMB-Inline; for Smart Printer; 1500 pieces on roll; stretchable 5 - 5.2 mm; plain; snap-on type; white	2009-115	2009-115	2009-115

IO-Link master ▶ 4-Port IO-Link Master Class A; I/O System Field; 24 VDC / 2.0 A; 4 x M12 Connector



765-4103/100-000

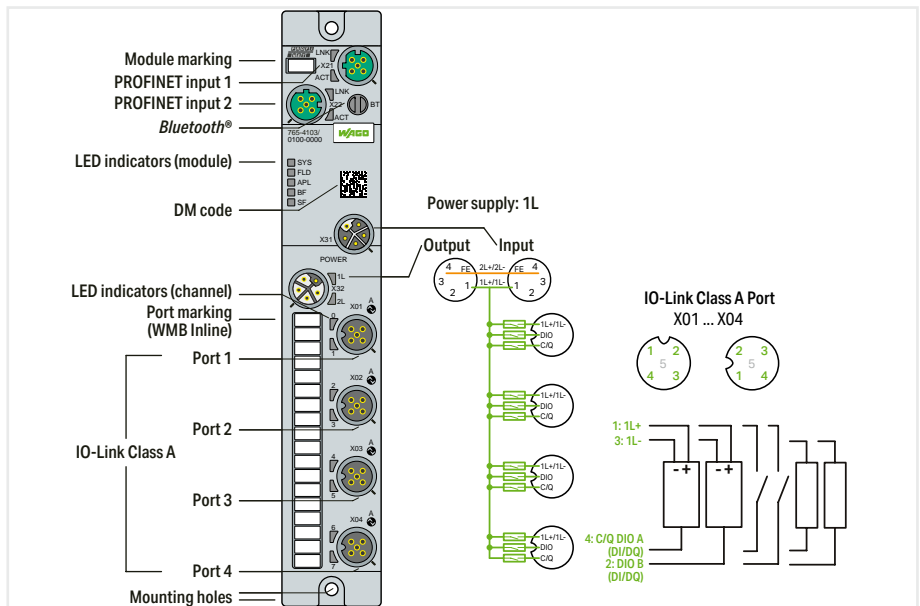

Item description	4-Port IO-Link Master Class A; I/O System Field; 24 VDC / 2.0 A; 4 x M12 Connector		
Version	PROFINET	EtherCAT®	EtherNet/IP™
Item no.	765-4103/100-000	765-4203/100-000	765-4503/100-000
Order Text	4PORT IOL-A FLD PN DC 24V 2.0A	4PORT IOL-A FLD EC DC 24V 2.0A	4PORT IOL-A FLD EI DC 24V 2.0A

Technical data			
Fieldbus			
Communication	PROFINET; PROFINET IO device; 2-port switch, LLLDP, MRP, SNMP	EtherCAT®; AoE, EoE, FoE	EtherNet/IP™; BOOTP, DHCP, DLR
Connection technology: communication/fieldbus	2 x D-coded M12; 4-pole		
Interface standard	10BASE-T/100BASE-TX; potential-free		
Autonegotiation; autocrossover	Yes		
Device functions	Input filter; Output current; Temperature		
Parameter	Undervoltage; overcurrent; overload; overtemperature		
Diagnostics	Bluetooth®; OPC UA server		
Device functions	Android/iOS app; Web server		
Visualization			
IO-Link master			
IO-Link master classification	Class A; V1.1 specification		
Port mode	IO-Link: autoconfig, manual, tool-based; DI; DO		
Cycle time	400 µs (min.)		
Operating mode	IO-Link master, DI or DO (adjustable for pin 4 per port); DI or DO (adjustable for pin 2 per port)		
IO-Link ports			
Number of digital inputs	8		
Number of digital outputs	8		
Connection technology: inputs/outputs	4 x A-coded M12; 5-pole		
Signal type (voltage)	24 VDC		
Input characteristic	high-side switching		
Input filter	0.2 ... 20 ms		
Input characteristic	Type 3, per IEC 61131-2		
Output current (per channel)	2 A (typ.) for DO		
Supply current per port	1L: 1 A for IO-Link; 4 A (max.) for DIO		
Supply (module)			
Connection technology: supply	2 x L-coded M12; 5-pole		
Supply voltage	24 VDC (18 ... 31.2 V); 1L		
Current consumption (max.)	16000 mA		
Current consumption (note)	per supply line; overload- and short-circuit-protected		
Reverse voltage protection	Yes		
Ambient temperature (operation)	-25 ... +70 °C		
Approvals	CE; FCC/ISED		
Approvals (pending)	OrdLoc		

For data sheet and additional information, see: wago.com/765-4103/100-000 wago.com/765-4203/100-000 wago.com/765-4503/100-000

Accessories	Item no.	Item no.	Item no.
Torque wrench M8 and M12; Assembly kit	206-701	206-701	206-701
M12 protective cap; for unused sockets	756-8102	756-8102	756-8102
M12 protective cap; for unused plugs	756-8103	756-8103	756-8103
Marking strips; for Smart Printer; on reel; not stretchable	2009-110	2009-110	2009-110
WMB-Inline; for Smart Printer; 1500 pieces on roll; stretchable 5 - 5.2 mm; plain; snap-on type; white	2009-115	2009-115	2009-115

IO-Link master ▶ 4-Port IO-Link Master Class B; I/O System Field; 24 VDC / 2.0 A; 4 x M12 Connector



765-4104/100-000

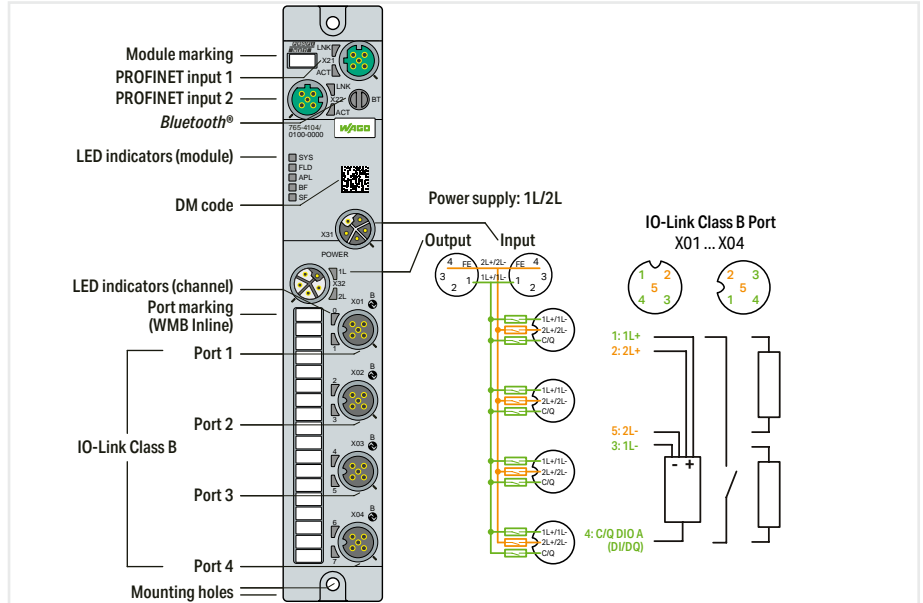

Item description	4-Port IO-Link Master Class B; I/O System Field; 24 VDC / 2.0 A; 4 x M12 Connector		
Version	PROFINET	EtherCAT®	EtherNet/IP™
Item no.	765-4104/100-000	765-4204/100-000	765-4504/100-000
Order Text	4PORT IOL-B FLD PN DC 24V 2.0A	4PORT IOL-B FLD EC DC 24V 2.0A	4PORT IOL-B FLD EI DC 24V 2.0A

Technical data			
Fieldbus			
Communication	PROFINET; PROFINET IO device; 2-port switch, LLDP, MRP, SNMP	EtherCAT®; AoE, EoE, FoE	EtherNet/IP™; BOOTP, DHCP, DLR
Connection technology: communication/fieldbus	2 x D-coded M12; 4-pole		
Interface standard	10BASE-T/100BASE-TX; potential-free		
Autonegotiation; autocrossover	Yes		
Device functions	Input filter; Output current; Temperature		
Parameter	Undervoltage; overcurrent; overload; overtemperature		
Diagnostics	Bluetooth®; OPC UA server		
Device functions	Android/iOS app; Web server		
Visualization			
IO-Link master			
IO-Link master classification	Class B; V1.1 specification		
Port mode	IO-Link: autoconfig, manual, tool-based; DI; DO		
Cycle time	400 µs (min.)		
Operating mode	IO-Link master, DI or DO (adjustable for pin 4 per port); Supply voltage 2L (fixed for pin 2 per port)		
IO-Link ports			
Number of digital inputs	4		
Number of digital outputs	4		
Connection technology: inputs/outputs	4 x A-coded M12; 5-pole		
Signal type (voltage)	24 VDC		
Input characteristic	high-side switching		
Input filter	0.2 ... 20 ms		
Input characteristic	Type 3, per IEC 61131-2		
Output current (per channel)	2 A (typ.) for DO		
Supply current per port	1L (pin 1): 1 A for IO-Link; 4 A (max.) for DIO; 2L (pin 2): 4 A (max.)	1L (Pin 1): 1 A for IO-Link; 4 A (max.) for DIO; 2L (Pin 2): 4 A (max.)	
Supply (module)			
Connection technology: supply	2 x L-coded M12; 5-pole		
Supply voltage	24 VDC (18 ... 31.2 V); 1L/2L		
Current consumption (max.)	16000 mA		
Current consumption (note)	per supply line; overload- and short-circuit-protected		
Reverse voltage protection	Yes		
Ambient temperature (operation)	-25 ... +70 °C		
Approvals	CE; FCC/ISED		
Approvals (pending)	OrdLoc		

For data sheet and additional information, see: wago.com/765-4104/100-000 wago.com/765-4204/100-000 wago.com/765-4504/100-000

Accessories	Item no.	Item no.	Item no.
Torque wrench M8 and M12; Assembly kit	206-701	206-701	206-701
M12 protective cap; for unused sockets	756-8102	756-8102	756-8102
M12 protective cap; for unused plugs	756-8103	756-8103	756-8103
Marking strips; for Smart Printer; on reel; not stretchable	2009-110	2009-110	2009-110
WMB-Inline; for Smart Printer; 1500 pieces on roll; stretchable 5 - 5.2 mm; plain; snap-on type; white	2009-115	2009-115	2009-115

IO-Link hub ▶ 8-Channel Digital Input/Output; I/O System Field; IO-Link Class A Hub; 24 VDC 2.0 A; 4 x M12 Connector



765-1701/200-000

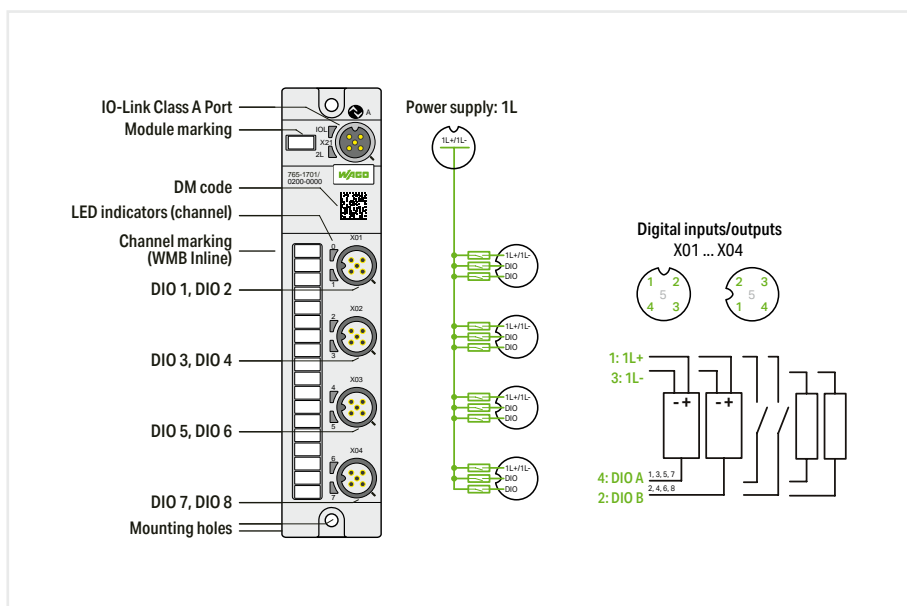

Item description	8-Channel Digital Input/Output; I/O System Field; IO-Link Class A Hub; 24 VDC 2.0 A; 4 x M12 Connector
Version	IO-Link hub (class A)
Item no.	765-1701/200-000
Order Text	8DIO FLD IOL-A HUB DC 24V 2.0A

Technical data	
IO-Link	
Communication	IO-Link slave (class A)
Connection technology: communication/fieldbus	1 x A-coded M12; 5-pole
Device functions	
Parameter	Input filter; Output current; Temperature
Diagnostics	Undervoltage; overcurrent; overload; overtemperature
Digital inputs/outputs	
Number of digital inputs	8
Number of digital outputs	8
Connection technology: inputs/outputs	4 x A-coded M12; 5-pole
Signal type (voltage)	24 VDC
Input characteristic	high-side switching
Input filter	0.2 ... 20 ms
Input characteristic	Type 3, per IEC 61131-2
Output current (per channel)	2 A
Supply	
Connection technology: supply	1 x A-coded M12; 5-pole; via IO-Link port (1L)
Supply voltage	24 VDC (18 ... 31.2 V); 1L
Current consumption (max.)	4000 mA
Current consumption (note)	1L: 0.2 A + load current
Reverse voltage protection	Yes
Ambient temperature (operation)	-25 ... +70 °C
Approvals	CE; FCC/ISED
Approvals (pending)	OrdLoc
For data sheet and additional information, see:	wago.com/765-1701/200-000

Accessories	Item no.
Torque wrench M8 and M12; Assembly kit	206-701
M12 protective cap; for unused sockets	756-8102
M12 protective cap; for unused plugs	756-8103
Marking strips; for Smart Printer; on reel; not stretchable; plain; snap-on type; white	2009-110
WMB-Inline; for Smart Printer; 1500 pieces on roll; stretchable 5 - 5.2 mm; plain; snap-on type; white	2009-115

IO-Link hub ▶ 8-Channel Digital Input/Output; I/O System Field; IO-Link Class B Hub; 24 VDC 2.0 A; 4 x M12 Connector



765-1704/200-000

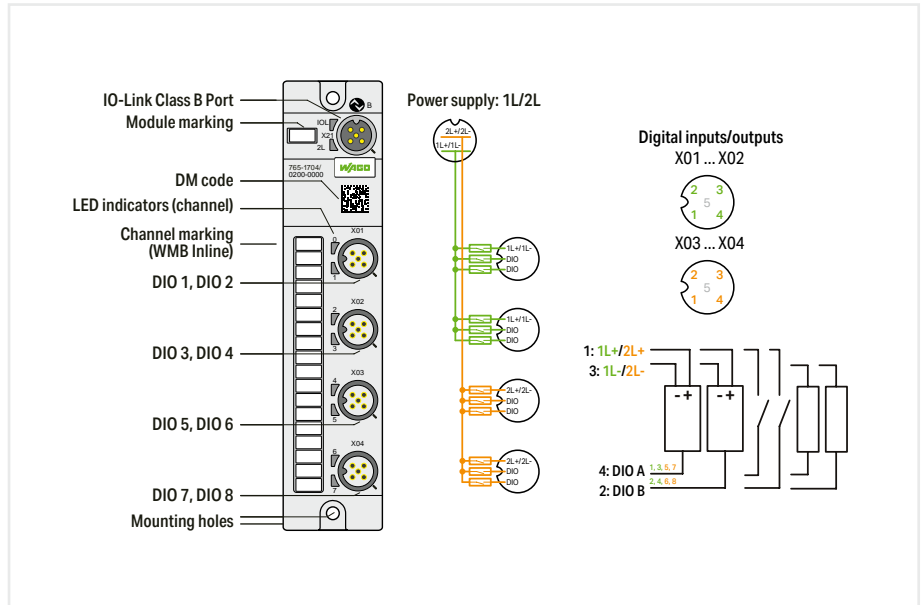

Item description	8-Channel Digital Input/Output; I/O System Field; IO-Link Class B Hub; 24 VDC 2.0 A; 4 x M12 Connector
Version	IO-Link hub (class B)
Item no.	765-1704/200-000
Order Text	8DIO FLD IOL-B HUB DC 24V 2.0A

Technical data	
IO-Link	
Communication	IO-Link slave (class B)
Connection technology: communication/fieldbus	1 x A-coded M12; 5-pole
Device functions	
Parameter	Input filter; Output current; Temperature
Diagnostics	Undervoltage; overcurrent; overload; overtemperature
Digital inputs/outputs	
Number of digital inputs	8
Number of digital outputs	8
Connection technology: inputs/outputs	4 x A-coded M12; 5-pole
Signal type (voltage)	24 VDC
Input characteristic	high-side switching
Input filter	0.2 ... 20 ms
Input characteristic	Type 3, per IEC 61131-2
Output current (per channel)	2 A
Supply	
Connection technology: supply	1 x A-coded M12; 5-pole; via IO-Link port (1L/2L)
Supply voltage	24 VDC (18 ... 31.2 V); 1L/2L
Current consumption (max.)	4000 mA
Current consumption (note)	1L: 0.2 A; 2L: 0.1 A; + load current
Reverse voltage protection	Yes
Ambient temperature (operation)	-25 ... +70 °C
Approvals	CE; FCC/ISED
Approvals (pending)	OrdLoc
For data sheet and additional information, see:	wago.com/765-1704/200-000

Accessories	
Torque wrench M8 and M12; Assembly kit	206-701
M12 protective cap; for unused sockets	756-8102
M12 protective cap; for unused plugs	756-8103
Marking strips; for Smart Printer; on reel; not stretchable; plain; snap-on type; white	2009-110
WMB-Inline; for Smart Printer; 1500 pieces on roll; stretchable 5 - 5.2 mm; plain; snap-on type; white	2009-115

9

IO-Link hub ▶ 8-Channel Digital Input/Output; I/O System Field; IO-Link Class A Hub; 24 VDC 2.0 A; 8 x M8 Connector



765-1702/200-000

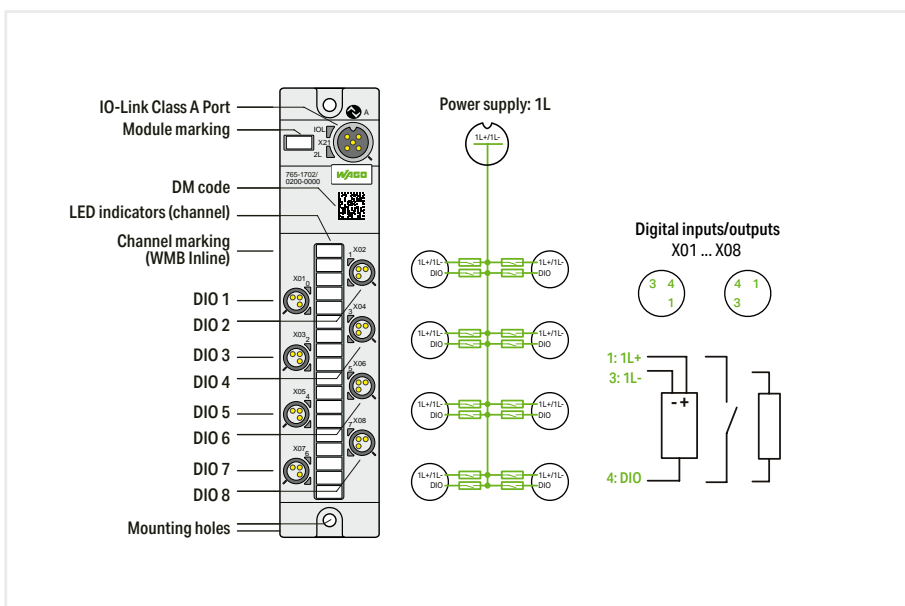

Item description	8-Channel Digital Input/Output; I/O System Field; IO-Link Class A Hub; 24 VDC 2.0 A; 8 x M8 Connector
Version	IO-Link hub (class B)
Item no.	765-1702/200-000
Order Text	8DIO FLD IOL-A HUB DC 24V 2.0A

Technical data	
IO-Link	
Communication	IO-Link slave (class A)
Connection technology: communication/fieldbus	1 x A-coded M12; 5-pole
Device functions	
Parameter	Input filter; Output current; Temperature
Diagnostics	Undervoltage; overcurrent; overload; overtemperature
Digital inputs/outputs	
Number of digital inputs	8
Number of digital outputs	8
Connection technology: inputs/outputs	8 x M8; 3-pole
Signal type (voltage)	24 VDC
Input characteristic	high-side switching
Input filter	0.2 ... 20 ms
Input characteristic	Type 3, per IEC 61131-2
Output current (per channel)	2 A
Supply	
Connection technology: supply	1 x A-coded M12; 5-pole; via IO-Link port (1L)
Supply voltage	24 VDC (18 ... 31.2 V); 1L
Current consumption (max.)	4000 mA
Current consumption (note)	1L: 0.2 A + load current
Reverse voltage protection	Yes
Ambient temperature (operation)	-25 ... +70 °C
Approvals	CE; FCC/ ISED
Approvals (pending)	OrdLoc
For data sheet and additional information, see:	wago.com/765-1702/200-000

Accessories	Item no.
Torque wrench M8 and M12; Assembly kit	206-701
M8 protective cap; for unused sockets	756-8101
M12 protective cap; for unused plugs	756-8103
Marking strips; for Smart Printer; on reel; not stretchable; plain; snap-on type; white	2009-110
WMB-Inline; for Smart Printer; 1500 pieces on roll; stretchable 5 - 5.2 mm; plain; snap-on type; white	2009-115

IO-Link hub ▶ 8-Channel Digital Input/Output; I/O System Field; IO-Link Class B Hub; 24 VDC 2.0 A; 8 x M8 Connector



765-1705/200-000

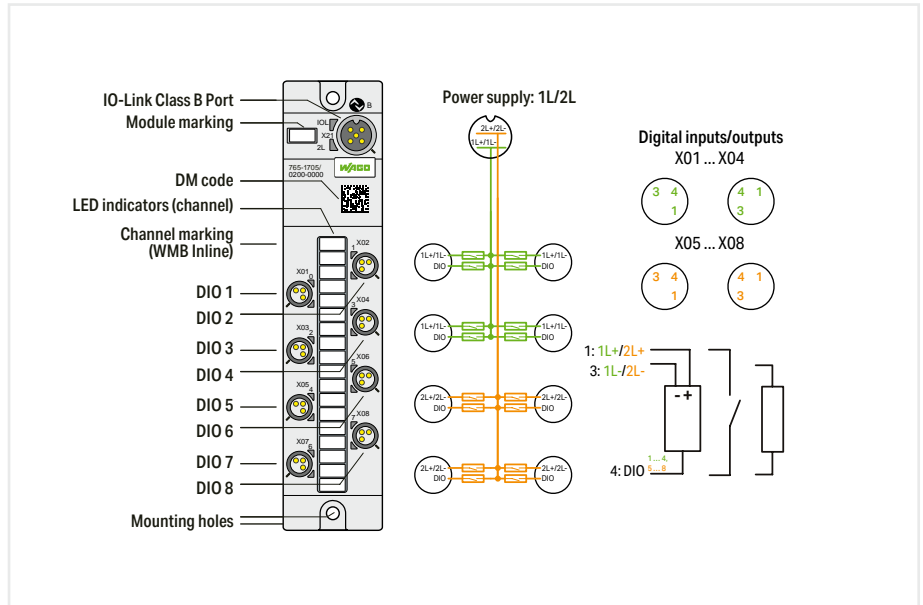

Item description	8-Channel Digital Input/Output; I/O System Field; IO-Link Class B Hub; 24 VDC 2.0 A; 8 x M8 Connector
Version	IO-Link hub (class A)
Item no.	765-1705/200-000
Order Text	8DIO FLD IOL-B HUB DC 24V 2.0A

Technical data	
IO-Link	
Communication	IO-Link slave (class B)
Connection technology: communication/fieldbus	1 x A-coded M12; 5-pole
Device functions	
Parameter	Input filter; Output current; Temperature
Diagnostics	Undervoltage; overcurrent; overload; overtemperature
Digital inputs/outputs	
Number of digital inputs	8
Number of digital outputs	8
Connection technology: inputs/outputs	8 x M8; 3-pole
Signal type (voltage)	24 VDC
Input characteristic	high-side switching
Input filter	0.2 ... 20 ms
Input characteristic	Type 3, per IEC 61131-2
Output current (per channel)	2 A
Supply	
Connection technology: supply	1 x A-coded M12; 5-pole; via IO-Link port (1L/2L)
Supply voltage	24 VDC (18 ... 31.2 V); 1L/2L
Current consumption (max.)	4000 mA
Current consumption (note)	1L: 0.2 A; 2L: 0.1 A; + load current
Reverse voltage protection	Yes
Ambient temperature (operation)	-25 ... +70 °C
Approvals	CE; FCC/ISED
Approvals (pending)	OrdLoc
For data sheet and additional information, see:	wago.com/765-1705/200-000

Accessories	Item no.
Torque wrench M8 and M12; Assembly kit	206-701
M8 protective cap; for unused sockets	756-8101
M12 protective cap; for unused plugs	756-8103
Marking strips; for Smart Printer; on reel; not stretchable; plain; snap-on type; white	2009-110
WMB-Inline; for Smart Printer; 1500 pieces on roll; stretchable 5 - 5.2 mm; plain; snap-on type; white	2009-115

IO-Link hub ▶ 16-Channel Digital Input/Output; I/O System Field; IO-Link Class A Hub; 24 VDC 2.0 A; 8 x M12 Connector



765-1703/200-000

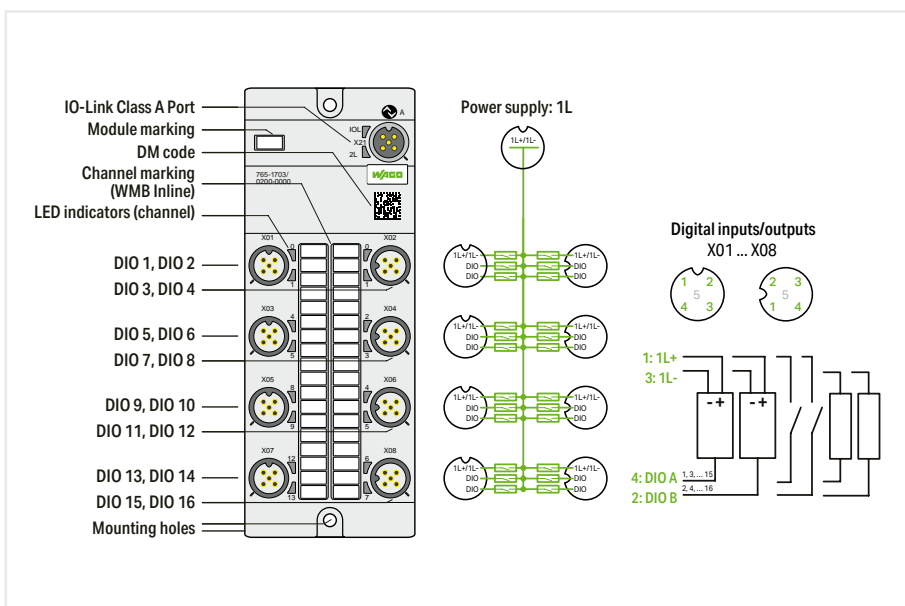

Item description	16-Channel Digital Input/Output; I/O System Field; IO-Link Class A Hub; 24 VDC 2.0 A; 8 x M12 Connector
Version	IO-Link hub (class A)
Item no.	765-1703/200-000
Order Text	16DIO FLD IOL-A HUB DC 24V 2.0A

Technical data	
IO-Link	
Communication	IO-Link slave (class A)
Connection technology: communication/fieldbus	1 x A-coded M12; 5-pole
Device functions	
Parameter	Input filter; Output current; Temperature
Diagnostics	Undervoltage; overcurrent; overload; overtemperature
Digital inputs/outputs	
Number of digital inputs	16
Number of digital outputs	16
Connection technology: inputs/outputs	8 x A-coded M12; 5-pole
Signal type (voltage)	24 VDC
Input characteristic	high-side switching
Input filter	0.2 ... 20 ms
Input characteristic	Type 3, per IEC 61131-2
Output current (per channel)	2 A
Supply	
Connection technology: supply	1 x A-coded M12; 5-pole; via IO-Link port (1L)
Supply voltage	24 VDC (18 ... 31.2 V); 1L
Current consumption (max.)	4000 mA
Current consumption (note)	1L: 0.2 A + load current
Reverse voltage protection	Yes
Ambient temperature (operation)	-25 ... +70 °C
Approvals	CE; FCC/ISED
Approvals (pending)	OrdLoc
For data sheet and additional information, see:	wago.com/765-1703/200-000

Accessories	
Torque wrench M8 and M12; Assembly kit	206-701
M12 protective cap; for unused sockets	756-8102
M12 protective cap; for unused plugs	756-8103
Marking strips; for Smart Printer; on reel; not stretchable; plain; snap-on type; white	2009-110
WMB-Inline; for Smart Printer; 1500 pieces on roll; stretchable 5 - 5.2 mm; plain; snap-on type; white	2009-115

IO-Link hub ▶ 16-Channel Digital Input/Output; I/O System Field; IO-Link Class B Hub; 24 VDC 2.0 A; 8 x M12 Connector



765-1706/200-000

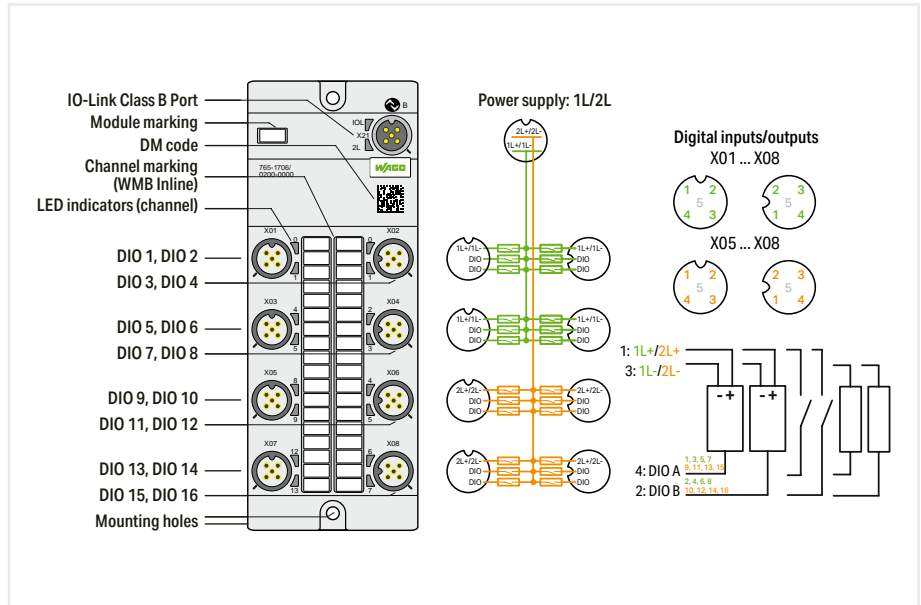

Item description	16-Channel Digital Input/Output; I/O System Field; IO-Link Class B Hub; 24 VDC 2.0 A; 8 x M12 Connector
Version	IO-Link hub (class B)
Item no.	765-1706/200-000
Order Text	16DIO FLD IOL-B HUB DC 24V 2.0A

Technical data	
IO-Link	
Communication	IO-Link slave (class B)
Connection technology: communication/fieldbus	1 x A-coded M12; 5-pole
Device functions	
Parameter	Input filter; Output current; Temperature
Diagnostics	Undervoltage; overcurrent; overload; overtemperature
Digital inputs/outputs	
Number of digital inputs	16
Number of digital outputs	16
Connection technology: inputs/outputs	8 x A-coded M12; 5-pole
Signal type (voltage)	24 VDC
Input characteristic	high-side switching
Input filter	0.2 ... 20 ms
Input characteristic	Type 3, per IEC 61131-2
Output current (per channel)	2 A
Supply	
Connection technology: supply	1 x A-coded M12; 5-pole; via IO-Link port (1L/2L)
Supply voltage	24 VDC (18 ... 31.2 V); 1L/2L
Current consumption (max.)	4000 mA
Current consumption (note)	1L: 0.2 A; 2L: 0.1 A; + load current
Reverse voltage protection	Yes
Ambient temperature (operation)	-25 ... +70 °C
Approvals	CE; FCC/ISED
Approvals (pending)	OrdLoc
For data sheet and additional information, see:	wago.com/765-1706/200-000

Accessories	
Torque wrench M8 and M12; Assembly kit	206-701
M12 protective cap; for unused sockets	756-8102
M12 protective cap; for unused plugs	756-8103
Marking strips; for Smart Printer; on reel; not stretchable; plain; snap-on type; white	2009-110
WMB-Inline; for Smart Printer; 1500 pieces on roll; stretchable 5 - 5.2 mm; plain; snap-on type; white	2009-115

1-Channel Analog Input; IO-Link Converter; 4 ... 20 mA

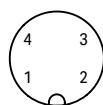

M12-A plug; 4-pole

- 1: 24 VDC: Supply 1L+
- 2: OUT2: Analog output
- 3: 0 V: Supply 1L-
- 4: OUT1: Digital output (SIO)/IO-Link

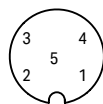

M12-A socket; 5-pole

- 1: Sensor supply 1L+
- 2: Analog input (4 ... 20 mA)
- 3: Sensor supply 1L-
- 4: not used
- 5: not used

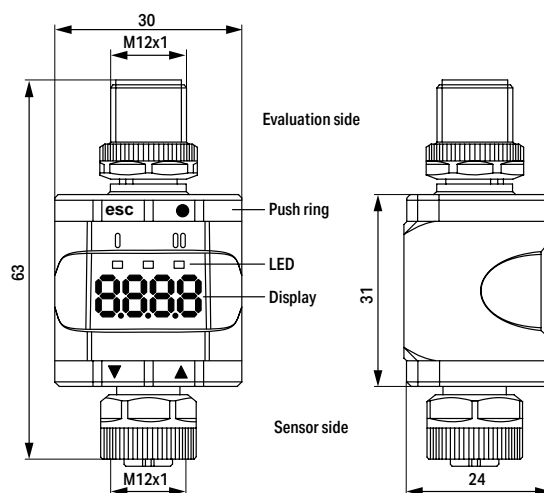

Item Description	1-Channel Analog Input; IO-Link Converter; 4 ... 20 mA
Item No.	765-2701/200-000
Order Text	1AI FLD IOL CONV 4-20mA
Technical Data	
Supply voltage	24 VDC; -25 ... +25 %; (18 ... 30 VDC)
Current consumption	30 ... 830 mA
Operation modes	SIO; IO-Link
Inputs	
Number of analog inputs	1
Connection technology	M12-A socket; 5-pole
Signal type (current)	4 ... 20 mA
Sensor supply	24 VDC
Sensor current	≤ 800 mA
Accuracy	0.5 % of the upper-range value
Outputs	
Digital output (OUT 1)	
Number of digital outputs	1
Connection technology	M12-A plug; 4-pole
Current carrying capacity per output	50 mA
Signal type (voltage)	10 ... 30 VDC
Output circuit design	Make/break contact; parameterizable
Analog output (OUT 2)	
Number of analog outputs	1
Signal type (current)	4 ... 20 mA
Accuracy	0.5 % of the upper-range value
Resolution	10 bits
IO-Link	
Communication interface	IO-Link Class A
Transmission type	COM2 (38.4 kBaud)
IO-Link revision	1.1
Process data	1 x 16-bit IN (analog); 1 x 16-bit IN (digital)
Process cycle time (min.)	3 ms
Parameters via IO-Link	Operating mode, switching point, delay, scaling, etc.
Indicators	Digital output: 1 x yellow LED; Power: 1 x green LED; Display: 7-segment red/green LED
Length of connection cables	30 m without IO-Link on each side; 20 m with IO-Link on the master side
Dimensions	63 x 30 x 24 mm
Ambient temperature (operation)	-20 ... +60 °C
Ambient temperature (storage)	-25 ... 70 °C
Protection type	IP67
Relative humidity (without condensation)	90 % (max.)
Approvals	CE, UL, IO-Link, MTTF (373 years)
For data sheet and additional information, see:	wago.com/765-2701/200-000
Accessories	Item No.
Mounting Clip	765-101/000-000

2-Channel Analog Input; IO-Link Converter; 0 ... 10 V

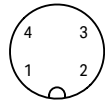

M12-A plug; 4-pole

- 1: 24 VDC: Supply 1L+
- 2: not used
- 3: 0 V: Supply 1L-
- 4: C/Q IO-Link

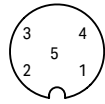

M12-A socket; 5-pole

- 1: Sensor supply 1L+
- 2: Analog input 2 (0 ... 10 V)
- 3: Sensor supply 1L-
- 4: Analog input 1 (0 ... 10 V)
- 5: not used

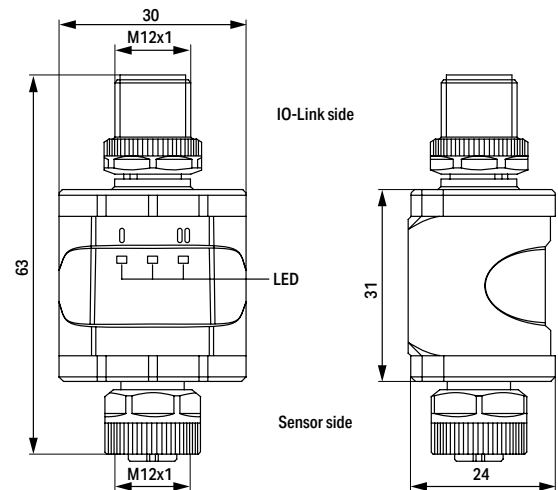

Item Description	2-Channel Analog Input; IO-Link Converter; 0 ... 10 V
Item No.	765-2702/200-000
Order Text	2AI FLD IOL CONV 0-10V
Technical Data	
Supply voltage	24 VDC; -25 ... +25 %; (18 ... 30 VDC)
Current consumption	< 380 mA
Inputs	
Number of analog inputs	2
Connection technology	M12-A socket; 5-pole
Signal type (voltage)	0 ... 10 V
Current carrying capacity for all inputs	200 mA (max.)
Input resistance	> 100 kΩ
Accuracy	0.25 % of the upper-range value
IO-Link	
Communication interface	IO-Link Class A/B
Transmission type	COM2 (38.4 kBaud)
IO-Link revision	1.1
Process data	2 x 16-bit IN (analog)
Process cycle time (min.)	4.6 ms
Parameters via IO-Link	Description, system identifier, location identifier, mean value filter
Indicators	
Length of connection cables	20 m
Dimensions	
Ambient temperature (operation)	-20 ... +60 °C
Ambient temperature (storage)	-25 ... 70 °C
Protection type	IP67
Relative humidity (without condensation)	90 % (max.)
Approvals	
For data sheet and additional information, see:	CE, UL, IO-Link, MTTF (504 years) wago.com/765-2702/200-000
Accessories	
Mounting Clip	765-101/000-000

2-Channel Analog Output; IO-Link Converter; 4 ... 20 mA

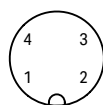

M12-A plug; 4-pole

- 1: 24 VDC: Supply 1L+
- 2: not used
- 3: 0 V: Supply 1L-
- 4: C/Q IO-Link

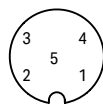

M12-A socket; 5-pole

- 1: Actuator supply 1L+
- 2: Analog output 2 (4 ... 20 mA)
- 3: Actuator supply 1L-
- 4: Analog output 1 (4 ... 20 mA)
- 5: not used

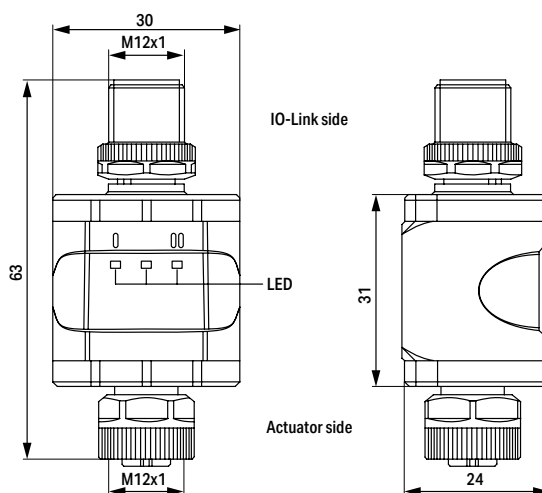

Item Description	2-Channel Analog Output; IO-Link Converter; 4 ... 20 mA
Item No.	765-2703/200-000
Order Text	2AO FLD IOL CONV 4-20mA
Technical Data	
Supply voltage	24 VDC; -25 ... +25 %; (18 ... 30 VDC)
Current consumption	300 mA
Current carrying capacity (module)	0.2 A
Operation modes	IO-Link
Outputs	
Number of analog outputs	2
Connection technology	M12-A socket; 5-pole
Signal type (current)	4 ... 20 mA
Load impedance	≤ 300 Ω
Accuracy	0.25 % of output range end value
IO-Link	
Communication interface	IO-Link Class A/B
Transmission type	COM2 (38.4 kBaud)
IO-Link revision	1.1
Process data	2 x 16-bit OUT (analog)
Process cycle time (min.)	3.6 ms
Parameters via IO-Link	Description
Indicators	Analog output: 2 x yellow LED; Power: 1 x green LED
Length of connection cables	20 m
Dimensions	63 x 30 x 24 mm
Ambient temperature (operation)	-20 ... +60 °C
Ambient temperature (storage)	-25 ... 70 °C
Protection type	IP67
Relative humidity (without condensation)	90 % (max.)
Approvals	CE, UL, IO-Link, MTTF (352 years)
For data sheet and additional information, see:	wago.com/765-2703/200-000
Accessories	Item No.
Mounting Clip	765-101/000-000

2-Channel Analog Output; IO-Link Converter; 0 ... 10 V

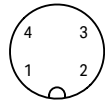

M12-A plug; 4-pole

- 1: 24 VDC: Supply 1L+
- 2: not used
- 3: 0 V: Supply 1L-
- 4: C/Q IO-Link

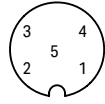

M12-A socket; 5-pole

- 1: Actuator supply 1L+
- 2: Analog output 2 (0 ... 10 V)
- 3: Actuator supply 1L-
- 4: Analog output 1 (0 ... 10 V)
- 5: not used

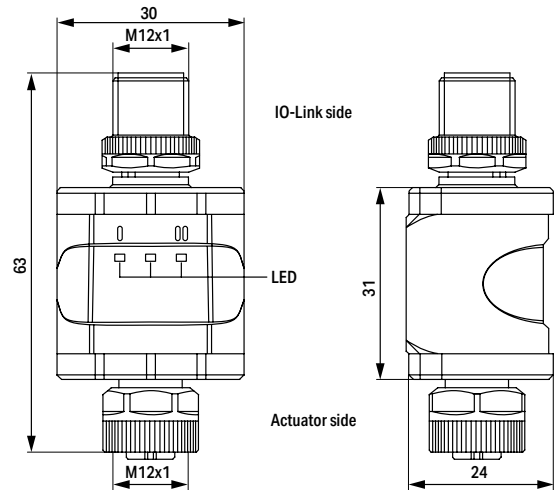

Item Description	2-Channel Analog Output; IO-Link Converter; 0 ... 10 V
Item No.	765-2704/200-000
Order Text	2AO FLD IOL CONV 0-10V
Technical Data	
Supply voltage	24 VDC; -25 ... +25 %; (18 ... 30 VDC)
Current consumption	300 mA
Current carrying capacity (module)	0.2 A
Operation modes	IO-Link
Outputs	
Number of analog outputs	2
Connection technology	M12-A socket; 5-pole
Signal type (voltage)	0 ... 10 V
Load impedance	≤ 3000 Ω
Accuracy	0.25 % of output range end value
IO-Link	
Communication interface	IO-Link Class A/B
Transmission type	COM2 (38.4 kBaud)
IO-Link revision	1.1
Process data	2 x 16-bit OUT (analog)
Process cycle time (min.)	3.6 ms
Parameters via IO-Link	Description, system identifier, location identifier
Indicators	Analog output: 2 x yellow LED; Power: 1 x green LED
Length of connection cables	20 m
Dimensions	63 x 30 x 24 mm
Ambient temperature (operation)	-20 ... +60 °C
Ambient temperature (storage)	-25 ... 70 °C
Protection type	IP67
Relative humidity (without condensation)	90 % (max.)
Approvals	C€, UL, IO-Link, MTTf (373 years)
For data sheet and additional information, see:	wago.com/765-2704/200-000
Accessories	Item No.
Mounting Clip	765-101/000-000

Power Cable; L-Coded; 5-Pole

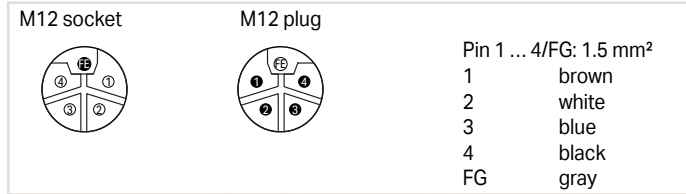

Operating voltage	60 VDC
Operating current	16 A / 40 °C (max.)
Surrounding air temperature (operation)	-30 ... +90 °C
Protection type	IP67
Cable diameter	9.9 mm ±0.3

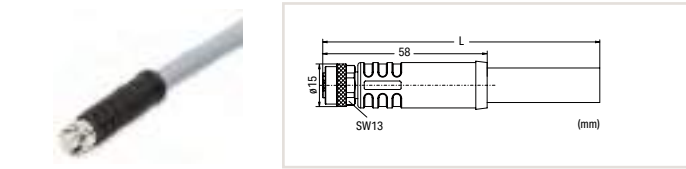

Power cable; pre-assembled on one end; M12 straight socket; L-coded		
Cable length	Item No.	PU
2 m	756-3501/050-020	1
5 m	756-3501/050-050	1
7.5 m	756-3501/050-075	1
10 m	756-3501/050-100	1
15 m	756-3501/050-150	1

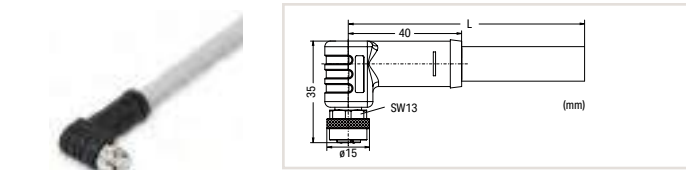

Power cable; pre-assembled on one end; M12 angled socket; L-coded		
Cable length	Item No.	PU
2 m	756-3502/050-020	1
5 m	756-3502/050-050	1
7.5 m	756-3502/050-075	1
10 m	756-3502/050-100	1
15 m	756-3502/050-150	1

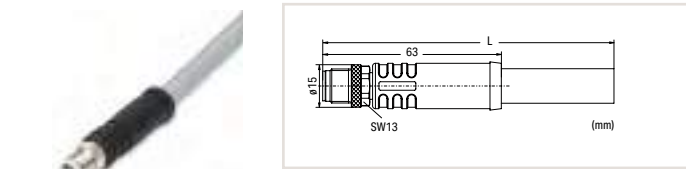

Power cable; pre-assembled on one end; M12 straight plug; L-coded		
Cable length	Item No.	PU
2 m	756-3503/050-020	1
5 m	756-3503/050-050	1
7.5 m	756-3503/050-075	1
10 m	756-3503/050-100	1
15 m	756-3503/050-150	1

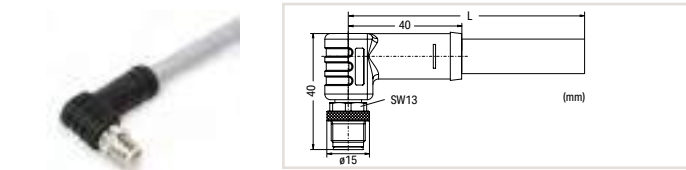

Power cable; pre-assembled on one end; M12 angled plug; L-coded		
Cable length	Item No.	PU
2 m	756-3504/050-020	1
5 m	756-3504/050-050	1
7.5 m	756-3504/050-075	1
10 m	756-3504/050-100	1
15 m	756-3504/050-150	1

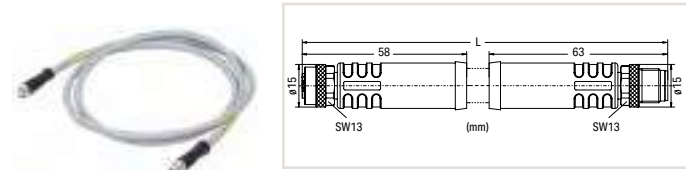

Power cable; pre-assembled on both ends; M12 straight socket/M12 straight plug; L-coded		
Cable length	Item No.	PU
0.3 m	756-3505/050-003	1
0.5 m	756-3505/050-005	1
1 m	756-3505/050-010	1
2 m	756-3505/050-020	1
5 m	756-3505/050-050	1
7.5 m	756-3505/050-075	1
10 m	756-3505/050-100	1
15 m	756-3505/050-150	1

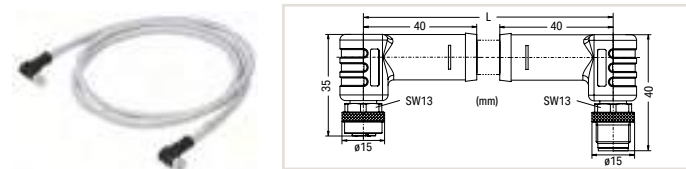

Power cable; pre-assembled on both ends; M12 angled socket/M12 angled plug; L-coded		
Cable length	Item No.	PU
0.3 m	756-3506/050-003	1
0.5 m	756-3506/050-005	1
1 m	756-3506/050-010	1
2 m	756-3506/050-020	1
5 m	756-3506/050-050	1
7.5 m	756-3506/050-075	1
10 m	756-3506/050-100	1
15 m	756-3506/050-150	1

9

ETHERNET/PROFINET Cable; D-Coded; 4-Pole

M12 plug



Pin 1 - 4: 0.34 mm²

- 1 yellow
- 2 white
- 3 orange
- 4 blue

Operating voltage	250 V
Operating current	4 A
Rated surge voltage	2 kV
Drag chain suitability	≥ 3 million bending cycles
Surrounding air (operating) temperature (dynamic)	-40 ... +70 °C
Protection type	IP67
Cable diameter	6.5 mm ±0.2

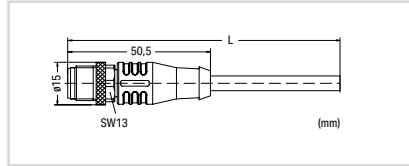

ETHERNET/PROFINET cable; pre-assembled on one end; M12 straight plug; D-coded

Cable length	Item No.	PU
2 m	756-1201/060-020	1
5 m	756-1201/060-050	1
10 m	756-1201/060-100	1
20 m	756-1201/060-200	1

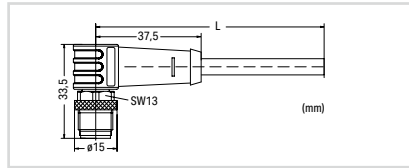

ETHERNET/PROFINET cable; pre-assembled on one end; M12 angled plug; D-coded

Cable length	Item No.	PU
2 m	756-1202/060-020	1
5 m	756-1202/060-050	1
10 m	756-1202/060-100	1
15 m	756-1202/060-200	1

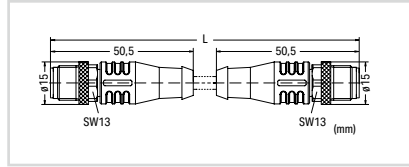

ETHERNET/PROFINET cable; pre-assembled on both ends; M12 plug – M12 plug; straight; D-coded

Cable length	Item No.	PU
2 m	756-1203/060-020	1
5 m	756-1203/060-050	1
10 m	756-1203/060-100	1
20 m	756-1203/060-200	1

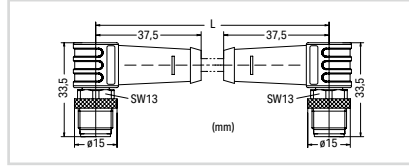

ETHERNET/PROFINET cable; pre-assembled on both ends; M12 plug – M12 plug; angled; D-coded

Cable length	Item No.	PU
2 m	756-1204/060-020	1
5 m	756-1204/060-050	1
10 m	756-1204/060-100	1
20 m	756-1204/060-200	1

Configurable Connector; 5-Pole; IDC Technology

M12 socket, L-coded	M12 plug, L-coded	Connectable cable: Ø 5.8 ... 13.5 mm 0.75 ... 1.5 mm ²

Rated current	12 A
Rated voltage	63 V
Rated surge voltage	1.5 kV
Surrounding air temperature (operation)	-40 ... +85 °C
Protection type	IP65; IP67 when mated; per IEC 60529
Cable diameter	5.8 ... 13.5 mm

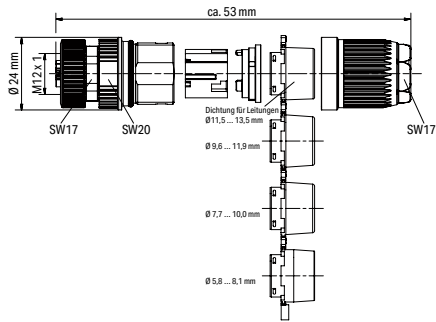

Configurable connector; 5-pole; IDC technology		
	Item No.	PU
M12-L socket; straight	756-9711/050-000	1

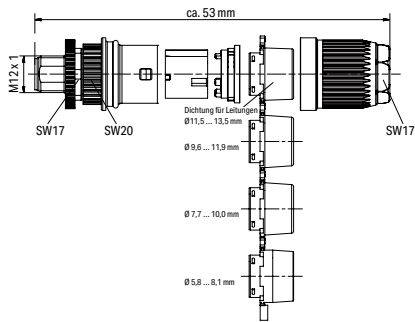

Configurable connector; 5-pole; IDC technology		
	Item No.	PU
M12-L plug; straight	756-9701/050-000	1

Mounting Clip

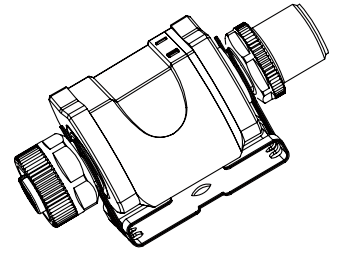
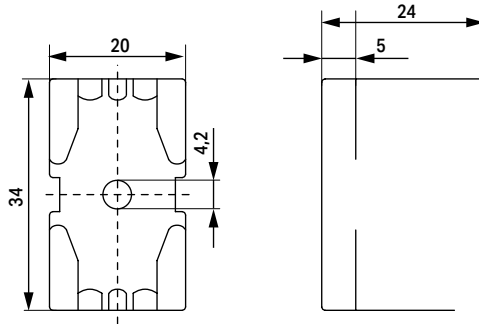

Figure: Mounting Clip (765-101/000-000)

Item Description	Mounting Clip
Version	for 765-2701/200-000, 765-2702/200-000, 765-2703/200-000 and 765-2704/200-000 Converters
Item No.	765-101/000-000
Technical Data	
Weight	6.8 g
Dimensions	34 x 20 x 24 mm
Material	Copper beryllium 2.1247 (CuBe2)









Industrial Switches

Industrial Switches

- Copper cables
- Fiber optic cables
- Ring redundancy

Industrial Switches

Contents

							Page	
General Product Information							582	
Functional Variants							583	
Configuration, Diagnostics and Performance							584	
Security							585	
Redundancy							586	
Product Overview							587	
		Number of Copper Ports		Number of SFP Ports		Number of PoE+ Ports	Item No.	
		100BASE-TX	1000BASE-T	100BASE-FX	1000BASE-SX/LX/ZX			
Industrial Unmanaged Switches								
	Eco Unmanaged	5					852-111	588
		5					852-111/000-001	589
		8					852-112	590
		8					852-112/000-001	591
		8					852-112/000-002	590
		5					852-1111/000-001	592
		8					852-1112	593
		5				4	852-1411	594
		5				4	852-1411/000-001	594
		5			2	4	852-1417	595
	Standard Unmanaged	5					852-101	596
		8					852-102	597
		8		2			852-103	598
		8					852-1102	599
		16					852-1106	600
Industrial Managed Switches								
	Lean Managed	8					852-1812	602
		8		2			852-1813	603
		8		2		8	852-1813/000-001	604
		16					852-1816	605
	MAC Security	8					852-1322	606
		6		2			852-1328	607
	Fully Managed	8		2			852-303	608
		8			4		852-1305	609
		8			4		852-1305/000-001	610
		8			4	8	852-1505	611
		8			4	8	852-1505/000-001	612
	PROFINET® Managed	8					852-602	613
		8		2			852-603	614
		8			4		852-1605	615
	Accessories	SFP Modules						616

Industrial Switches

General Product Information

Always the Right Solution

WAGO's range of switches ensures the scalability of your ETHERNET network infrastructure, while providing outstanding electrical and mechanical performance. These rugged switches are designed for industrial use and are fully compliant with IEEE 802.3, IEEE 802.3u and IEEE 802.3ab.

Combinable with Fiber Optic Cables

ETHERNET via fiber optic cables offers a multitude of advantages for industrial applications.

High immunity to interference, electrical isolation and long ranges up to 80 km are extremely beneficial characteristics – and these benefits are a perfect fit with the IT environment.

Scaled Selection

Unmanaged and managed switches in various designs are available for high-end applications. WAGO's Eco Switches are ideal for cost-sensitive applications that do not require technical features such as redundancy. They are ideal for small- to medium-sized networks.

Modular and Expandable

Exchangeable SPF modules adapt WAGO's switches to various fiber optic cables (FOC) and the associated required distances and fibers. These SFP modules are available for multimode and single-mode fiber optic cables for ranges up to 80 km. With the exact combination of copper and fiber optic cables, you are prepared for a multitude of requirements.

Web-Based Management

WAGO's fully managed switches have integrated Web-based management. Any Web browser can be used to configure the switch.

Integrated Function Monitoring

For monitoring and error reporting, WAGO's managed switch have configurable functions such as an email alarm and SNMP traps. Additionally, all switches (except for Eco versions) can monitor individual ports or the power supply via a potential-free alarm contact. A DIP switch configures this function.

Full Bandwidth on All Ports

The WAGO Switches' internal bandwidth is designed so that all ports can communicate simultaneously – in full duplex without restrictions.

Security

WAGO's managed switches have built-in security features, such as:

- Authentication
- Access control lists
- DHCP snooping
- Port security

Data Transmission

WAGO's managed switches provide configuration options for data transmission, such as:

- VLAN
- IGMP snooping
- IP-based VLAN
- MAC-based VLAN

Redundancy

Select industrial switches have several options for building redundant network structures and guarantee secure communication – even when connections are faulty:

- Rapid Spanning Tree per IEEE 802.1w – compatible with the IT standard
- Jet Ring – a simple ring protocol with switching time < 300 ms
- Xpress Ring – a fast ring protocol with switching time < 20 ms
- ERPSv2 per ITU-T standard, switching time < 50 ms
- Media Redundancy Protocol (MRP), switching time < 200 ms

In addition to communication link redundancy, a redundant power supply – which can also be monitored using an alarm relay – is integrated into the switches. If the power supply fails, communication is not interrupted.

Different Operating Modes

The unmanaged switches are ideal for direct plug-and-play use. Managed switches are available for applications where IP filtering or further interpretation of telegrams is required for the application.

Configurable Performance

WAGO's managed switches offer performance control features, such as:

- Storm control
- Bandwidth control
- Auto-provisioning
- Link aggregation

Configuration and Diagnostics

Modbus® can be used to diagnose managed switches. Configuration and diagnostics can also be performed with standardized protocols such as SNMP.

Select products also have the "PROFINET Conformance Class B" certificate, allowing simple diagnostics and configuration in PROFINET systems.

Advantages:

- Adaptable to different transmission media
- Automatically adapts to
 - Speed (auto-negotiation)
 - Wiring (auto-crossover, MDI/MDIX)
- Optional redundancy
- Wide supply voltage range

Industrial Switches

Functional Variants

Eco Unmanaged (A, B)

- Plug & play operation (Auto MDI-X)
- Megabit and gigabit variants
- Vibration and shock resistance
- DIN-rail adapter

- 1) Power supply
- 2) Status LEDs
- 3) Copper ports
- 4) Power over Ethernet (PoE+) ports
- 5) SFP ports for SFP modules

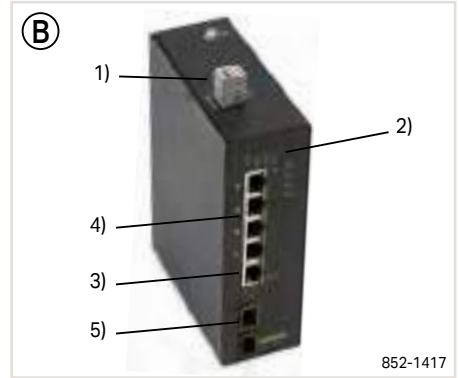
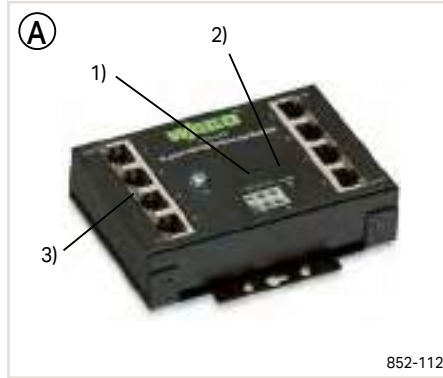

Standard Unmanaged (C, D)

- Up to 16-Gbit ports + SFP slots
- Diagnostics via LEDs and relay
- High temperature range (-40 ... +70 °C)
- Redundant power supply

- 1) Redundant power supply
- 2) Status and diagnostic LEDs
- 3) Copper ports
- 4) SFP ports for SFP modules
- 5) DIP switches for configuration

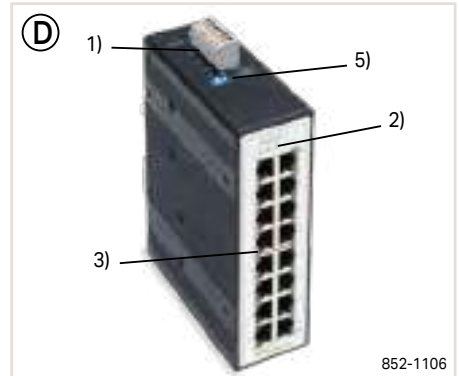
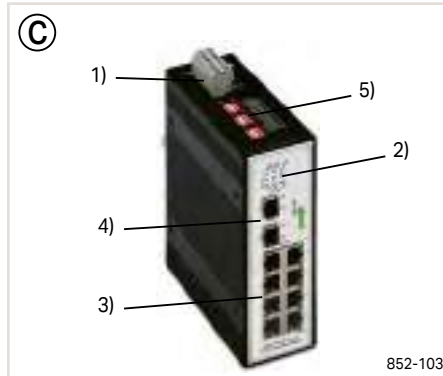

Lean Managed (E, F)

- Intuitive configuration for automation engineers
- Simple network diagnostics in the browser
- Media redundancy with RSTP/ERPS
- Network security basic functions

- 1) Redundant power supply
- 2) Status and diagnostic LEDs
- 3) Copper ports
- 4) Power over Ethernet (PoE+) ports
- 5) SFP ports for SFP modules
- 6) DIP switches for configuration

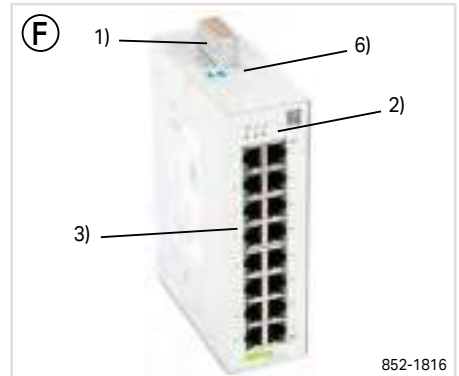
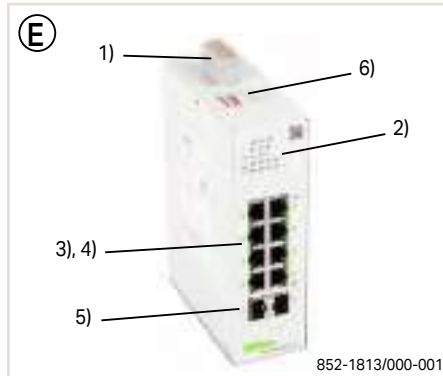

PROFINET® Managed (G, H)

- Configuration/diagnostics in the PROFINET® system
- PROFINET®-certified (CC-B)
- Cyclically readable process image
- Potential-free networking over 80 km

- 1) Redundant power supply
- 2) Status and diagnostic LEDs
- 3) Copper ports
- 4) SFP ports for SFP modules
- 5) RS-232 port
- 6) DIP switches for configuration

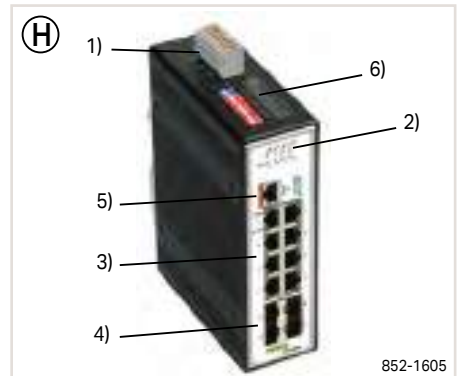
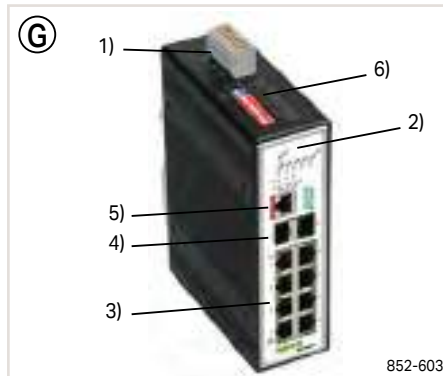

Fully Managed (I, J)

- Fast network redundancy (< 30 ms)
- Diagnostics (SNMPv3, Modbus®, Syslog, ...)
- Security (SSH, VLAN, 802.1X, ACL, ...)
- Extended network functions
- (Routing, IPv6, LACP, DHCP, ...)

- 1) Redundant power supply
- 2) Status and diagnostic LEDs
- 3) Copper ports
- 4) SFP ports for SFP modules
- 5) RS-232 port
- 6) DIP switches for configuration
- 7) USB interface

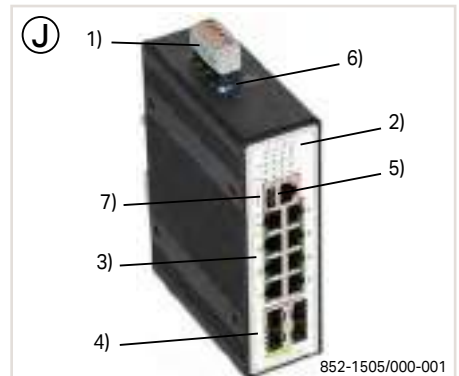
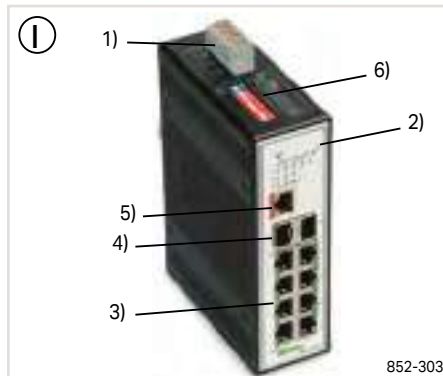

Industrial Switches

Configuration, Diagnostics and Performance

Configuration and Diagnostics

Several options:

- Configuration via Web-Based Management
- Configuration via command line (SSH, Telnet, RS-232)
- Network management via SNMP v1, v2c, v3
- Support of Management Information Base (MIB) standards
- PROFINET configuration via device description file (GSD file)
- Diagnostics via Modbus TCP:
Comprehensive data available for easy diagnostics via Modbus®

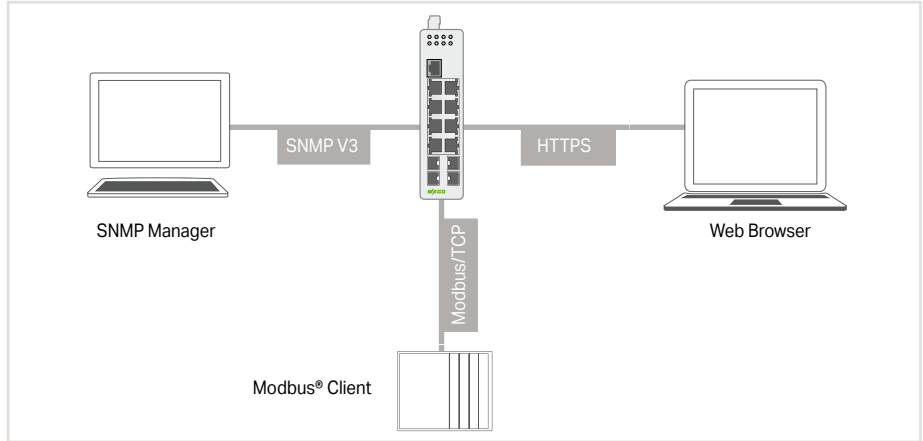

Configuration interfaces

Logical Network Segmentation

VLAN (e.g., per IEEE 802.1Q) and segmentation into virtual networks:

- Broadcast limitation
- Network security improvement
- Data flow prioritization
- Subdivision of machines and office networks

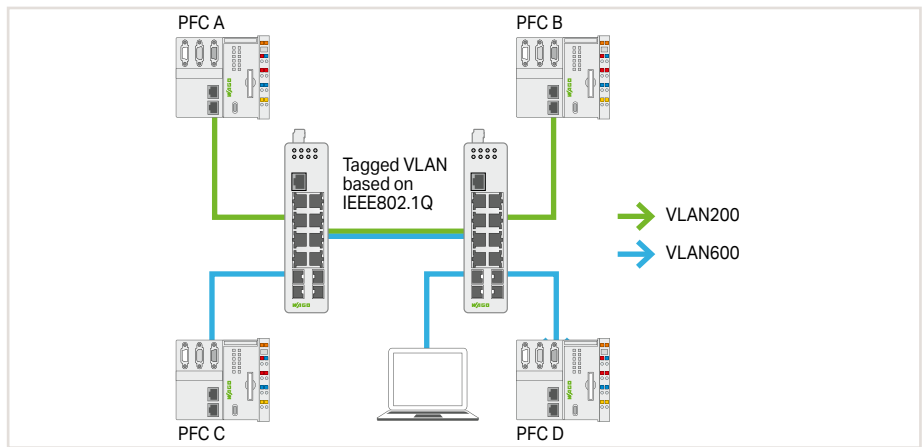

VLAN

Data Traffic Prioritization and Limitation

- Faster transfer of important data packets through the switch
- Prioritization of data packets per IEEE 802.1 Q
- Limitation of the bandwidth or number of packets per unit of time per port
- Increase in data transmission quality

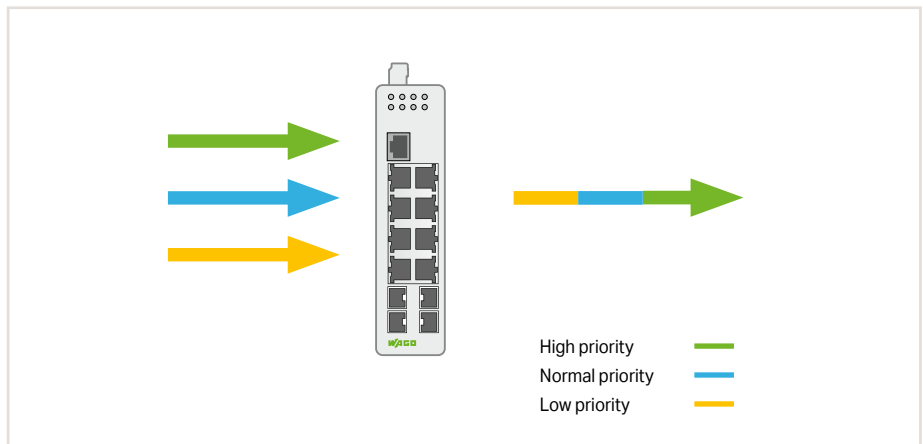

QoS

Mastering Data Traffic

- Stopping broadcast storms
- Ensuring network availability
- Limiting broadcast and multicast data flows (packets/time)

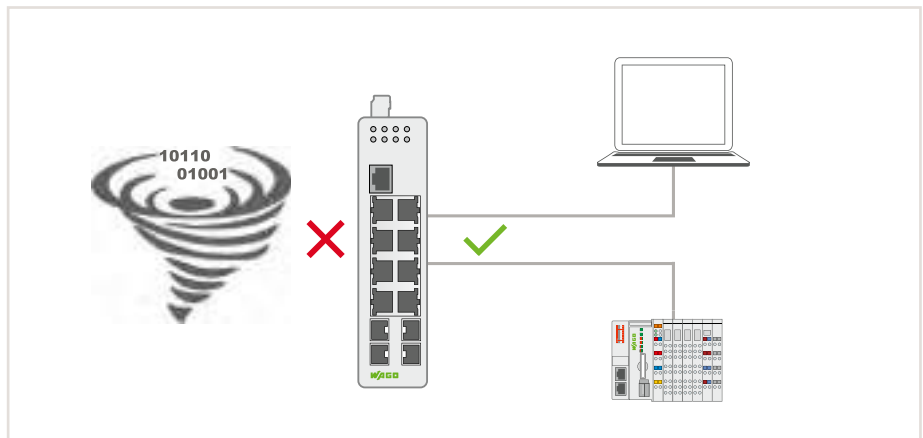

Storm Control

10

Industrial Switches Security

Authentication (IEEE 802.1X)

Secure authentication and authorization in ETHERNET networks (locally on the switch or via RADIUS server)

Process:

- Authentication of a subscriber is performed by the authenticator.
- The authenticator checks the authentication information of the subscriber (supplicant) with an authentication server.

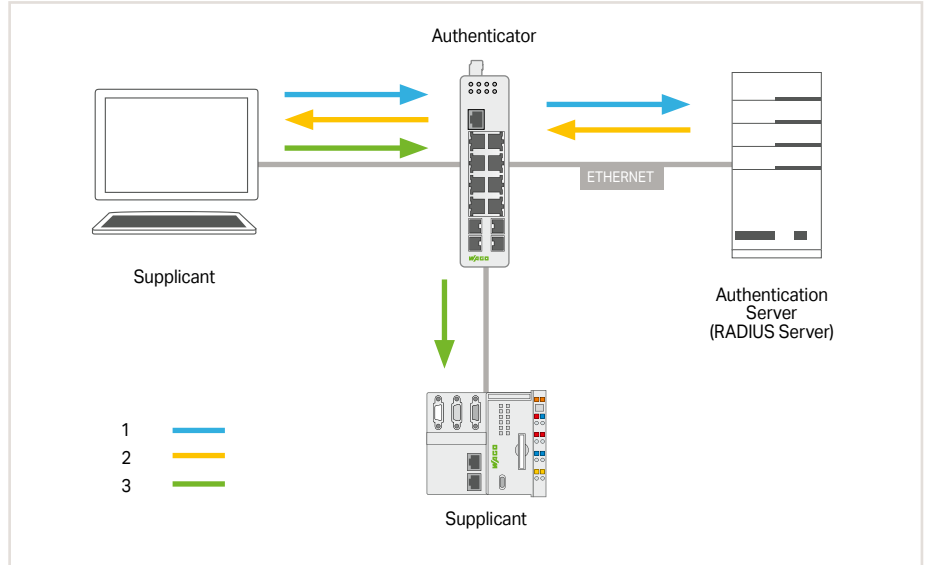

IEEE 802.1X

Firewall – Access Control List

Authorization Only for the Required Services

Filtering data packets via:

- Source MAC or source IP address
- Destination MAC or destination IP address
- Range of MAC or IP addresses
- UDP/TCP source or destination ports
- MAC-based white/black list for each port

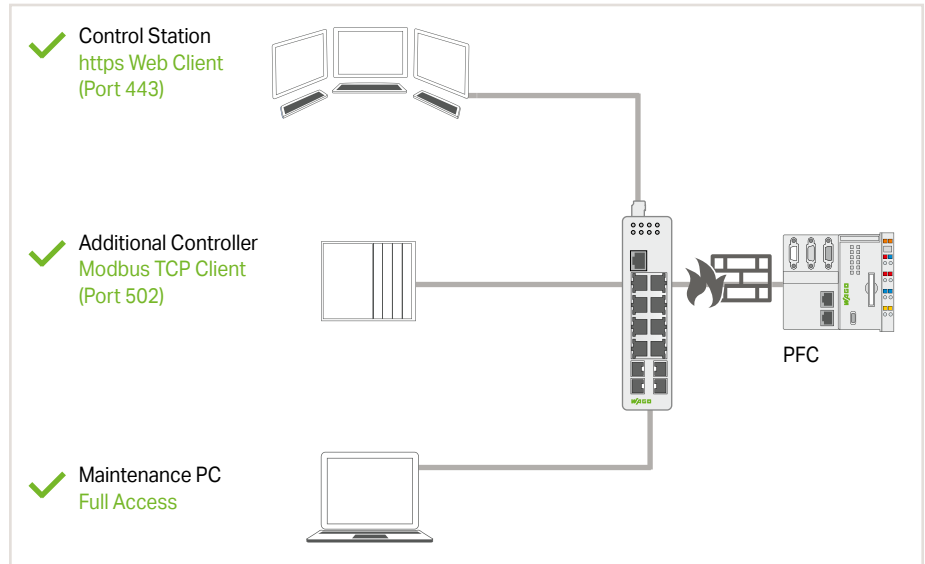

Firewall

Port Security

- Dynamically learns MAC addresses for each port
- Limitation of MAC addresses for each port
- MAC-based white/black list for each port

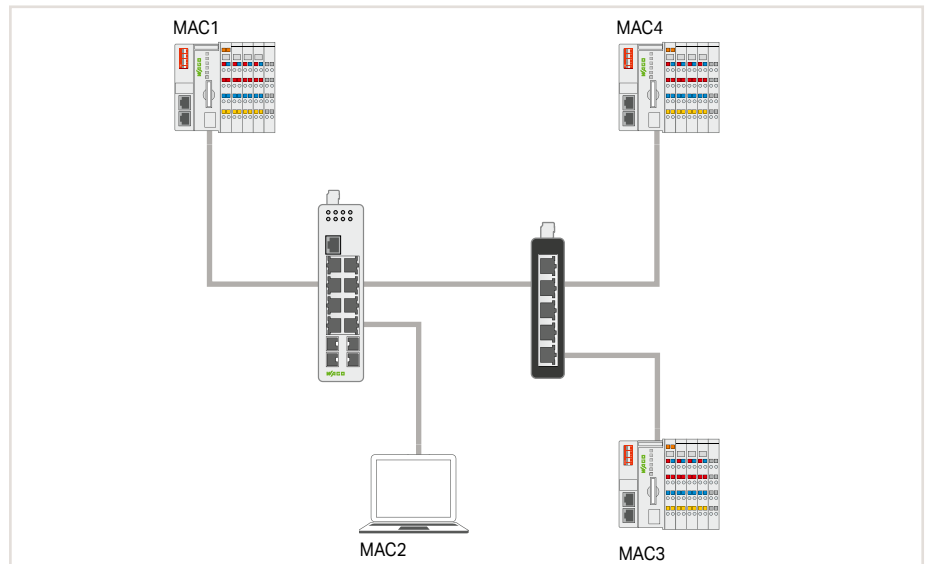

Industrial Switches Redundancy

Jet Ring

- Typical switching time of 400 ms (depends on the application)
- Extremely easy configuration (on or off)
- Up to 20 switches in a Jet Ring
- WAGO ETHERNET devices (Fast Aging) can be used in the Jet Ring

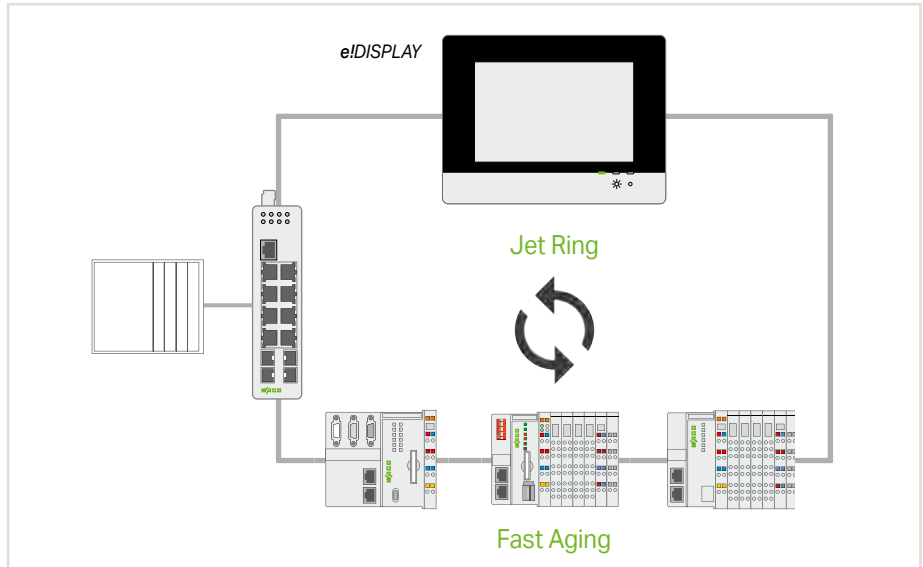

Jet Ring

Xpress Ring

- Switching time < 20 ms
- Easy configuration (3 parameters per switch)
- Up to 200 switches in one Xpress Ring
- 2 Xpress Rings per switch

Dual Ring

- Combination of both redundancy types
- 1 Jet Ring and 1 Xpress Ring per switch

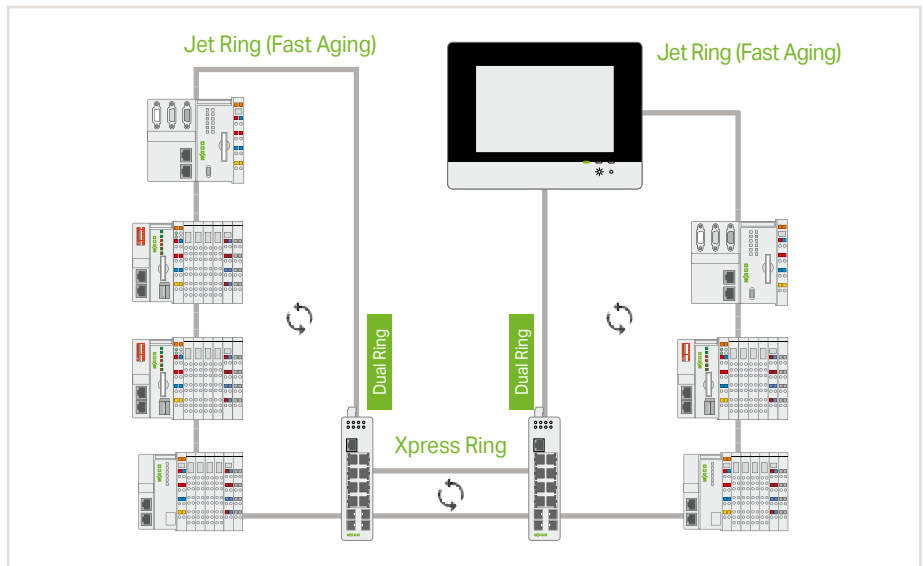

Xpress Ring and Dual Ring

ERPS: ETHERNET Ring Protection Switching

- Standardized and open technology
- Switching time < 50 ms
- Nested topologies with up to 6 rings per switch
- Implementation of one-fault tolerance (SPOF – Single Point of Failure)

ERPS – Enhancement Mode

- WAGO devices with an integrated switch and fast aging configuration
- Typical switching time of 400 ms (depends on the application)

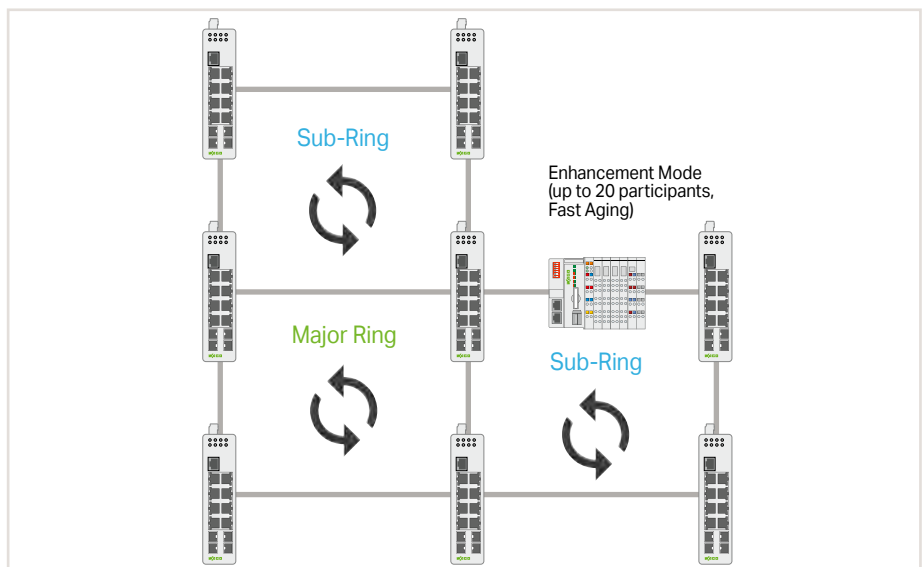

ERPS V2

Industrial Switches

Product Overview

	Unmanaged										Managed																	
	Eco					Standard					Lean Managed		MACsec		Fully Managed		PROFINET®											
	852-111	852-112	852-111/000-001	852-112	852-1411	852-1411/000-001	852-1417	852-101	852-102	852-103	852-1102	852-1106	852-1812	852-1813	852-1813/000-001	852-1816	852-1322	852-1328	852-303	852-1305	852-1305/000-001	852-1505	852-1505/000-001	852-602	852-603	852-1605		
Hardware	Number of copper ports	5	8	5	8	5	5	5	5	8	8	8	8	16	8	8	8	16	8	6	8	8	8	8	8	8	8	
	100 Mbit/s	☑	☑	☑	☑	☑	☑	☑	☑	☑	☑	☑	☑	☑	☑	☑	☑	☑	☑	☑	☑	☑	☑	☑	☑	☑	☑	
	1 Gbit/s			☑	☑	☑	☑					☑	☑	☑	☑	☑	☑	☑			☑	☑	☑	☑			☑	
	PoE+ ports among these (1 Gbit/s)	-	-	-	-	4	4	4	-	-	-	-	-	-	-	8	-	-	-	-	-	-	8	8	-	-	-	
	Number of SFP ports	-	-	-	-	-	-	2	-	-	2	-	-	-	2	2	-	-	2	2	4	4	4	4	4	-	2	4
	100 Mbit/s										☑				☑	☑					☑	☑					☑	
	1 Gbit/s							☑							☑	☑					☑	☑	☑	☑	☑		☑	☑
Alarm relay								☑	☑	☑	☑	☑	☑	☑	☑	☑				☑	☑	☑	☑	☑	☑	☑	☑	
Approvals, Standards, Certificates	CE	☑	☑	☑	☑	☑	☑	☑	☑	☑	☑	☑	☑	☑	☑	☑	☑	☑	☑	☑	☑	☑	☑	☑	☑	☑	☑	
	DNV GL	☑		☑																	☑	☑					☑	
	UL 61010	☑	☑	☑	☑	☑	☑	☑	☑	☑	☑	☑	☑	☑	☑	☑	☑	☑	☑	☑	☑	☑	☑	☑	☑	☑	☑	
	IEC 61850-3																						☑	☑				
	PROFINET® CC-B (certificate)																									☑	☑	☑
Hardware Features	Status LEDs			☑	☑	☑	☑	☑	☑	☑	☑	☑	☑	☑	☑	☑	☑	☑	☑	☑	☑	☑	☑	☑	☑	☑	☑	
	Autonegotiation	☑	☑	☑	☑	☑	☑	☑	☑	☑	☑	☑	☑	☑	☑	☑	☑	☑	☑	☑	☑	☑	☑	☑	☑	☑	☑	
	Auto-crossing	☑	☑	☑	☑	☑	☑	☑	☑	☑	☑	☑	☑	☑	☑	☑	☑	☑	☑	☑	☑	☑	☑	☑	☑	☑	☑	
	PROFINET CC-A			☑	☑	☑	☑								☑	☑	☑	☑	☑	☑	☑	☑	☑	☑	☑	☑	☑	
Configuration	DIP switches (diagnostics)							☑	☑	☑	☑	☑	☑	☑	☑	☑				☑	☑	☑	☑	☑	☑	☑	☑	
	Web-Based Management (http, https)														☑	☑	☑	☑	☑	☑	☑	☑	☑	☑	☑	☑	☑	
	SNMP (MIB)														☑	☑	☑	☑	☑	☑	☑	☑	☑	☑	☑	☑	☑	
	CLI (SSH, Telnet)														☑	☑	☑	☑			☑	☑	☑	☑	☑	☑	☑	
	CLI with RS-232																				☑	☑	☑	☑	☑	☑	☑	
	PROFINET configurator (GSD file)																									☑	☑	☑
	USB storage																							☑	☑			
Diagnostics	Status LED (LINK active)	☑	☑	☑	☑	☑	☑	☑	☑	☑	☑	☑	☑	☑	☑	☑	☑	☑	☑	☑	☑	☑	☑	☑	☑	☑	☑	
	Status LED (LINK down)							☑	☑	☑	☑				☑	☑	☑				☑	☑	☑	☑	☑	☑	☑	
	Status LED (alarm)							☑	☑	☑	☑	☑			☑	☑	☑				☑	☑	☑	☑	☑	☑	☑	
	SNMP (MIB)														☑	☑	☑	☑	☑	☑	☑	☑	☑	☑	☑	☑	☑	
	SNMP traps														☑	☑	☑	☑	☑	☑	☑	☑	☑	☑	☑	☑	☑	
	Modbus® registers														☑	☑	☑	☑	☑	☑	☑	☑	☑	☑	☑	☑	☑	
	Web-Based Management (http, https)														☑	☑	☑	☑	☑	☑	☑	☑	☑	☑	☑	☑	☑	
	Dashboard and topology map														☑	☑	☑	☑			☑	☑	☑	☑	☑	☑	☑	
	PROFINET diagnostics (acyclic and cyclic)																									☑	☑	☑
Redundancy	Neighborhood detection (LLDP)													☑	☑	☑	☑			☑	☑	☑	☑	☑	☑	☑	☑	
	Redundant power supply							☑	☑	☑	☑	☑	☑	☑	☑	☑	☑	☑	☑	☑	☑	☑	☑	☑	☑	☑	☑	
	Jet Ring																				☑	☑	☑	☑				
	Xpress Ring																				☑	☑	☑	☑				
	ETHERNET Ring Protection Switching														☑ ³	☑ ³	☑ ³	☑ ³			☑	☑	☑	☑				
	Media Redundancy Protocol (MRP) (client/manager)																									☑	☑	☑
Network Security	RSTP/STP													☑	☑	☑	☑	☑ ²	☑ ²	☑	☑	☑	☑	☑	☑	☑	☑	
	Segmentation (VLAN)													☑ ⁴	☑ ⁴	☑ ⁴	☑ ⁴	☑ ²	☑ ²	☑	☑	☑	☑	☑	☑	☑	☑	
	Authentication (IEEE 802.1X)													☑	☑	☑	☑	☑	☑	☑	☑	☑	☑	☑	☑	☑	☑	
	Access Control List (MAC, IP, Port)													☑ ⁵	☑ ⁵	☑ ⁵	☑ ⁵			☑	☑	☑	☑	☑	☑	☑	☑	
	Port security													☑	☑	☑	☑	☑ ²	☑ ²	☑	☑	☑	☑	☑	☑	☑	☑	
Data Transmission and Performance	MAC security (IEEE 802.1AE)																			☑	☑							
	LACP link aggregation																				☑	☑	☑	☑	☑	☑	☑	
	Prioritization (IEEE 802.1 p)	☑ ⁶	☑ ⁶	☑	☑	☑	☑	☑							☑	☑	☑	☑	☑	☑	☑	☑	☑	☑	☑	☑	☑	
	Quality of service (IEEE 802.1 Q)														☑	☑	☑	☑	☑ ²	☑ ²	☑	☑	☑	☑	☑	☑	☑	
	Bandwidth limitation																				☑	☑	☑	☑	☑	☑	☑	
	Broadcast limitation														☑	☑	☑	☑			☑	☑	☑	☑	☑	☑	☑	
	Routing within VLANs																				☑	☑	☑	☑	☑	☑	☑	
Static route																					☑	☑	☑	☑	☑	☑	☑	

¹DNV GL and LR starting from hardware version 5 or 3

²Firmware 2 or higher

³Supports two ERPS rings with a switchover time of less than 800 ms

⁴Supports up to five VLANs

⁵Supports up to 32 entries (based on MAC and IP address)

⁶applies to variant 852-111/000-001; 852-112/000-001 and 852-112/000-002

ECO Unmanaged ▶ 5 ports 100BASE-TX



852-111

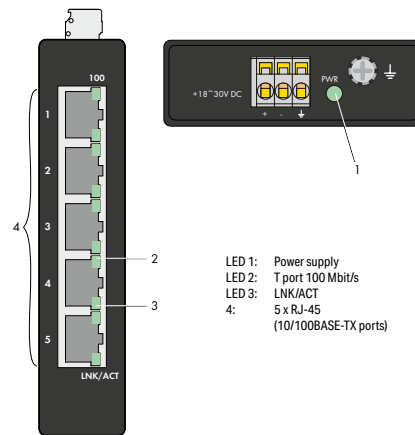

Item no.

852-111

Order Text

Industrial-Eco-Switch; 5Port

Technical data

Switching mode	Store-and-forward; non-blocking
Number of copper ports	5 x 100BASE-TX (RJ-45)
Communication standards	IEEE 802.3 10BASE-T; IEEE 802.3u 100BASE-TX; IEEE 802.3x Flow Control
MAC table (size)	2000 addresses
Topology	Star
Jumbo frame size	1536 bytes
Supply voltage	18 ... 30 VDC
Power consumption (max.)	3 W
ESD (contact/air discharge)	4 KV / 8 KV
Connection technology: communication/fieldbus	Copper cable: 5 x RJ-45
Ambient temperature (operation)	-40 ... +70 °C (UL max. +60 °C)
Dimensions W x H x D	(23.4 x 109.2 x 73.8) mm
Approvals	CE; DNV GL; OrdLoc wago.com/852-111

For data sheet and additional information, see:

ECO Unmanaged ▶ 5 ports 100BASE-TX



852-111/000-001

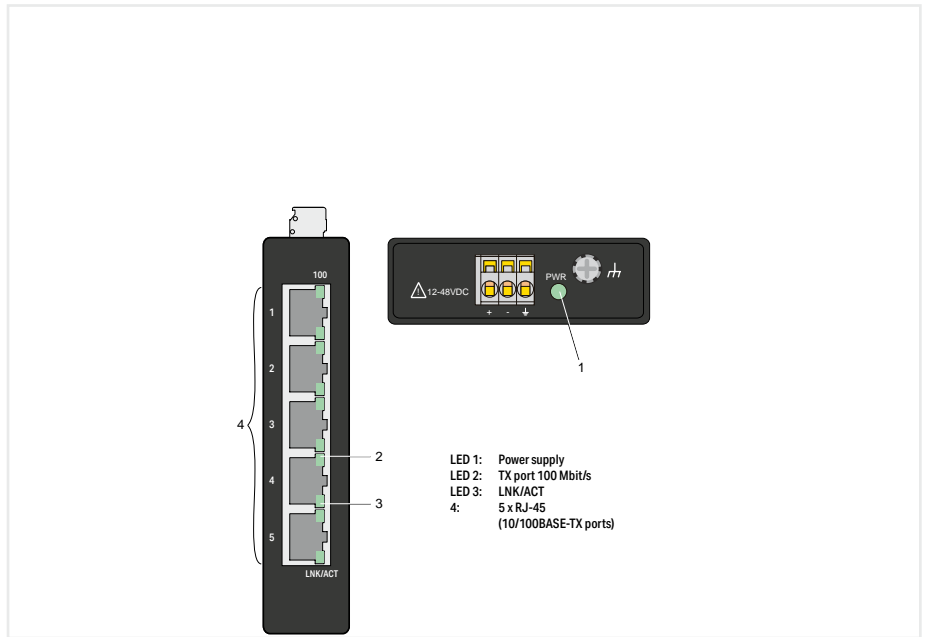

Item no.
Order Text

852-111/000-001
Industrial-Eco-Switch; 5Port

Technical data

Switching mode	Store-and-forward; non-blocking
Number of copper ports	5 x 100BASE-TX (RJ-45)
Communication standards	IEEE 802.3 10BASE-T; IEEE 802.3u 100BASE-TX; IEEE 802.3x Flow Control; IEEE 802.1p Prioritization
MAC table (size)	2000 addresses
Topology	Star
Supply voltage	12 ... 48 VDC
Power consumption (max.)	2 W
Connection technology: communication/fieldbus	Copper cable: 5 x RJ-45
Ambient temperature (operation)	-40 ... +70 °C
Dimensions W x H x D	(23.4 x 109.2 x 73.8) mm
For data sheet and additional information, see:	wago.com/852-111/000-001

ECO Unmanaged ► 8 ports 100BASE-TX



852-112

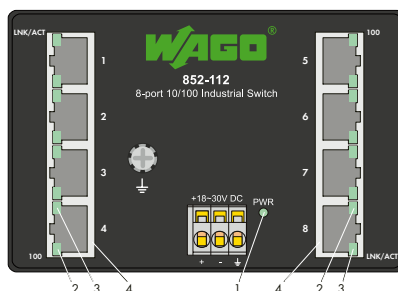

LED 1: Power supply
 LED 2: TX port 100 Mbit/s
 LED 3: LNK/ACT
 4: 8 x RJ-45
 (10/100BASE-TX ports)

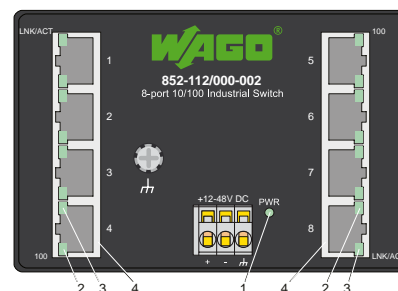

LED 1: Power supply
 LED 2: TX port 100 Mbit/s
 LED 3: LNK/ACT
 4: 8 x RJ-45
 (10/100BASE-TX ports)

Item no.	852-112
Order Text	Industrial-Eco-Switch; 8Port

Item no.	852-112
Order Text	Industrial-Eco-Switch; 8Port

Item no.	852-112/000-002
Order Text	Industrial-Eco-Switch; 8Port

Technical data

Switching mode	Store-and-forward; non-blocking
Number of copper ports	8 x 100BASE-TX (RJ-45)
Communication standards	IEEE 802.3 10BASE-T; IEEE 802.3u 100BASE-TX; IEEE 802.3x Flow Control

Switching mode	Store-and-forward; non-blocking
Number of copper ports	8 x 100BASE-TX (RJ-45)
Communication standards	IEEE 802.3 10BASE-T; IEEE 802.3u 100BASE-TX; IEEE 802.3x Flow Control

Switching mode	Store-and-forward; non-blocking
Number of copper ports	8 x 100BASE-TX (RJ-45)
Communication standards	IEEE 802.3 10BASE-T; IEEE 802.3u 100BASE-TX; IEEE 802.3x Flow Control; IEEE 802.1p Prioritization; IEEE 802.3 Nway Autonegotiation

MAC table (size)	2000 addresses
Topology	Star
Jumbo frame size	1536 bytes
Supply voltage	18 ... 30 VDC
Power consumption (max.)	3 W
ESD (contact/air discharge)	4 KV / 8 KV
Connection technology: communication/fieldbus	Copper cable: 8 x RJ-45
Ambient temperature (operation)	-40 ... +70 °C (UL max. +60 °C)
Dimensions W x H x D	(109.2 x 73.8 x 24) mm
Approvals	CE, UL, OrdLoc

MAC table (size)	2000 addresses
Topology	Star
Jumbo frame size	1536 bytes
Supply voltage	18 ... 30 VDC
Power consumption (max.)	3 W
ESD (contact/air discharge)	4 KV / 8 KV
Connection technology: communication/fieldbus	Copper cable: 8 x RJ-45
Ambient temperature (operation)	-40 ... +70 °C (UL max. +60 °C)
Dimensions W x H x D	(109.2 x 73.8 x 24) mm
Approvals	CE, UL, OrdLoc

MAC table (size)	8192 Adressen
Topology	Star
Jumbo frame size	9216 bytes
Supply voltage	12 ... 48 VDC; (±15 %); 12 ... 48 VDC (UL)
Power consumption (max.)	2 W
ESD (contact/air discharge)	-
Connection technology: communication/fieldbus	Copper cable: 8 x RJ-45
Ambient temperature (operation)	-40 ... +70 °C
Dimensions W x H x D	(109.2 x 73.8 x 24) mm
Approvals	CE, UL, OrdLoc

For data sheet and additional information, see:

wago.com/852-112

wago.com/852-112

ECO Unmanaged ▶ 8 ports 100BASE-TX



852-112/000-001

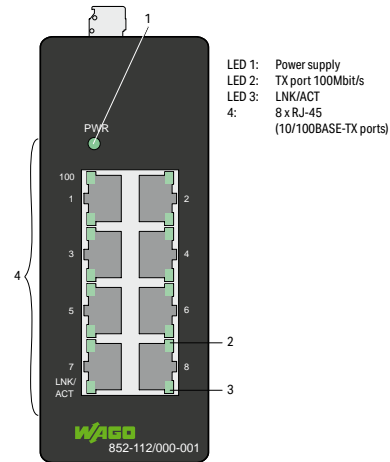

Item no.	852-112/000-001
Order Text	Industrial-Eco-Switch; 8Port
Technical data	
Switching mode	Store-and-forward; non-blocking
Number of copper ports	8 x 100BASE-TX (RJ-45)
Communication standards	IEEE 802.3 10BASE-T; IEEE 802.3u 100BASE-TX; IEEE 802.3x Flow Control; IEEE 802.1p Prioritization
Topology	Star
Supply voltage	12 ... 48 VDC
Power consumption (max.)	2 W
Connection technology: communication/fieldbus	Copper cable: 8 x RJ-45
Ambient temperature (operation)	-40 ... +70 °C
Dimensions W x H x D	(23.4 x 109.2 x 73.8) mm
Approvals	CE; OrdLoc
For data sheet and additional information, see:	wago.com/852-112

ECO Unmanaged ▶ 5 ports 1000BASE-T



852-1111/000-001

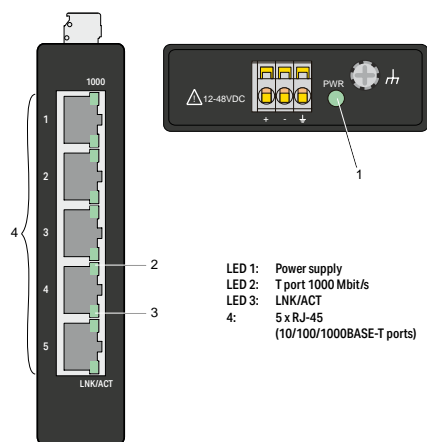

Item no.	852-1111/000-001
Order Text	Industrial-Eco-Switch; 5-Port Gb
Technical data	
Switching mode	Store-and-forward; non-blocking
Number of copper ports	5 x 1000BASE-T or 100BASE-TX (RJ-45)
Communication standards	IEEE 802.3 10BASE-T; IEEE 802.3u 100BASE-TX; IEEE 802.3ab 1000BASE-T; IEEE 802.3x Flow Control; IEEE 802.1p Prioritization
MAC table (size)	2000 addresses
Topology	Star
Jumbo frame size	9216 bytes
Supply voltage	12 ... 48 VDC; (±15 %); 24 ... 48 VDC (UL)
Power consumption (max.)	4 W
Connection technology: communication/fieldbus	Copper cable: 5 x RJ-45
Ambient temperature (operation)	-40 ... +70 °C
Dimensions W x H x D	(23.4 x 109.2 x 73.8) mm
Approvals	CE, OrdLoc
For data sheet and additional information, see:	wago.com/852-1111/000-001

ECO Unmanaged ▶ 8 ports 1000BASE-T



852-1112

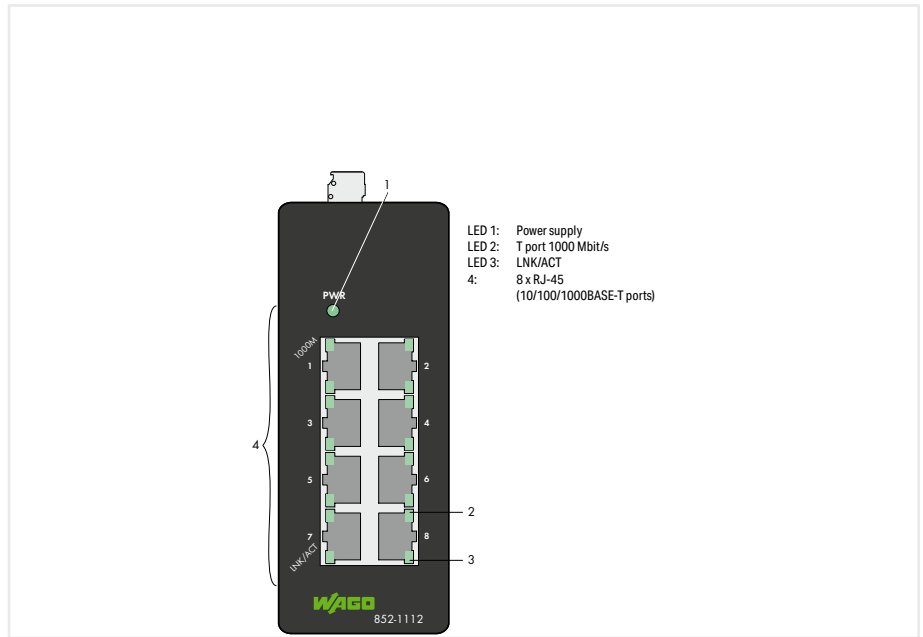

Item no.
Order Text

852-1112
Industrial-Eco-Switch; 8-Port Gb

Technical data

Switching mode	Store-and-forward; non-blocking
Number of copper ports	8 x 1000BASE-T or 100BASE-TX (RJ-45)
Communication standards	IEEE 802.3 10BASE-T; IEEE 802.3u 100BASE-TX; IEEE 802.3ab 1000BASE-T; IEEE 802.3x Flow Control; IEEE 802.3az Energy Efficient Ethernet; IEEE 802.1p Prioritization
MAC table (size)	8000 addresses
Topology	Star
Jumbo frame size	9000 bytes
Supply voltage	9 ... 57 VDC
Power consumption (max.)	6 W
ESD (contact/air discharge)	8 KV / 15 KV
Connection technology: communication/fieldbus	Copper cable: 8 x RJ-45
Ambient temperature (operation)	0 ... +60 °C
Dimensions W x H x D	(46 x 116 x 110) mm
Approvals	CE; OrdLoc
For data sheet and additional information, see:	wago.com/852-1112

ECO Unmanaged ▶ 5 ports 1000BASE-T; 4 * Power over Ethernet



852-1411

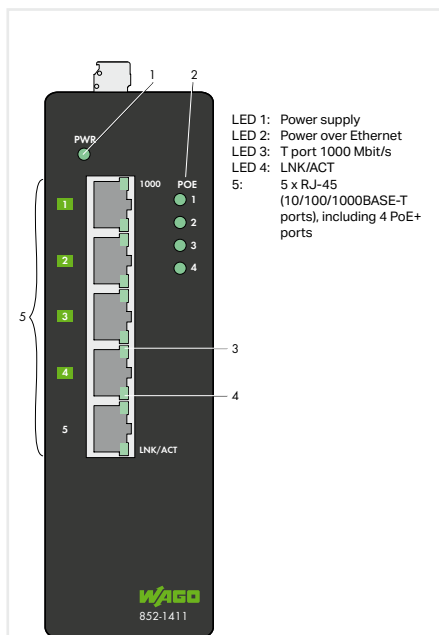

852-1411

Industrial-Eco-Switch; 5Port Gb; 4PoE

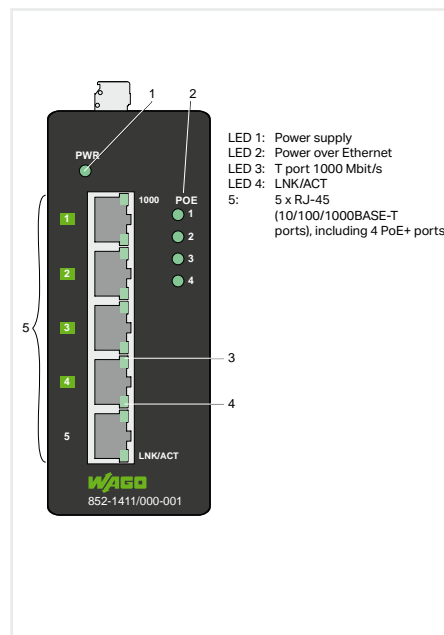

852-1411/000-001

Industrial-Eco-Switch; 5Port Gb; 4PoE

Item no.

Order Text

Technical data

Number of copper ports

Communication standards

MAC table (size)

Topology

Jumbo frame size

Supply voltage

Power consumption (max.)

Power consumption (note)

Connection technology: communication/fieldbus

Ambient temperature (operation)

Dimensions W x H x D

Approvals

For data sheet and additional information, see:

5 x 1000BASE-T or 100BASE-TX (RJ-45); 4 x PoE+ (Power over Ethernet)

IEEE 802.3 10BASE-T; IEEE 802.3u 100BASE-TX; IEEE 802.3ab 1000BASE-T; IEEE 802.3x Flow Control; IEEE 802.3af Power over Ethernet (PoE); IEEE 802.3at High Power over Ethernet (PoE+); IEEE 802.1p Prioritization

8000 addresses

Star

10000 bytes

24 ... 57 VDC

13 W

133 W with 4 PoE

Copper cable: 5 x RJ-45

-40 ... +70 °C (per CE; -10 ... +60 °C per UL 61010)

(50 x 160 x 120) mm

CE, OrdLoc

wago.com/852-1411

5 x 1000BASE-T or 100BASE-TX (RJ-45); 4 x PoE+ (Power over Ethernet)

IEEE 802.3 10BASE-T; IEEE 802.3u 100BASE-TX; IEEE 802.3ab 1000BASE-T; IEEE 802.3x Flow Control; IEEE 802.3af Power over Ethernet (PoE); IEEE 802.3at High Power over Ethernet (PoE+); IEEE 802.1p Prioritization

8000 addresses

Star

10000 bytes

24 ... 57 VDC

13 W

133 W with 4 PoE

Copper cable: 5 x RJ-45

-40 ... +70 °C (per CE; -10 ... +60 °C per UL 61010)

(50 x 104 x 115) mm

CE, OrdLoc; FCC approval (This device complies with Part 15 Subpart B, Class A of the FCC Rules)

wago.com/852-1411

ECO Unmanaged ▶ 5 ports 1000BASE-T; 2 slots 1000BASE-SX/LX; 4 * Power over Ethernet



852-1417

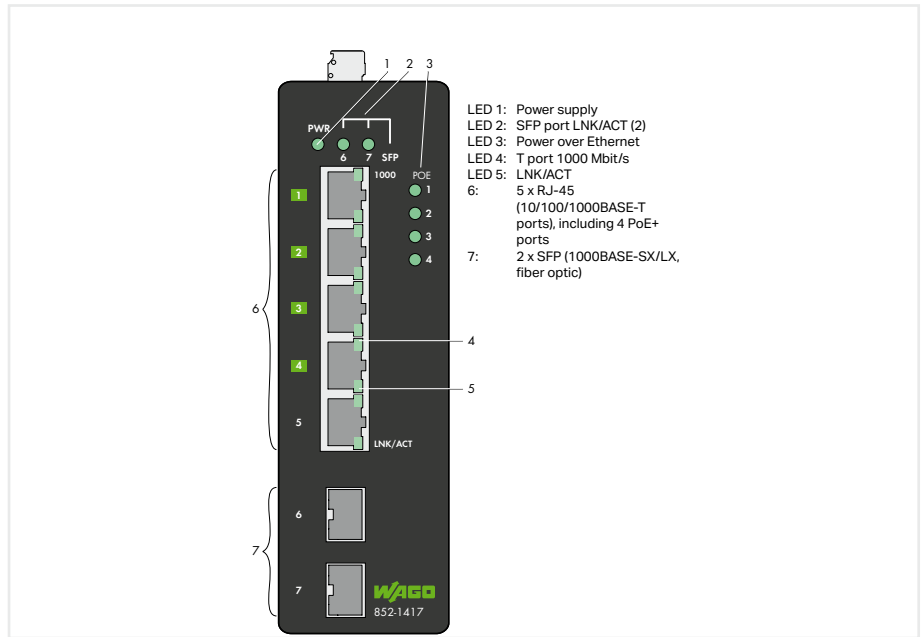

Item no.
Order Text

852-1417
Industrial-Eco-Switch; 5Port Gb; 2-Slot 1000BASE-SX/LX; 4PoE

Technical data

Number of copper ports	5 x 1000BASE-T or 100BASE-TX (RJ-45); 4 x PoE+ (Power over Ethernet)
Number of FOC ports	2 x 1000BASE-SX/LX (SFP slot)
Communication standards	IEEE 802.3 10BASE-T; IEEE 802.3u 100BASE-TX/FX; IEEE 802.3ab 1000BASE-T; IEEE 802.3z 1000BASE-SX/LX; IEEE 802.3x Flow Control; IEEE 802.3af Power over Ethernet (PoE); IEEE 802.3at High Power over Ethernet (PoE+); IEEE 802.1p Prioritization
MAC table (size)	8000 addresses
Topology	Star
Jumbo frame size	10000 bytes
Supply voltage	24 ... 57 VDC
Power consumption (max.)	14 W
Power consumption (note)	134 W with 4 PoE
Connection technology: communication/fieldbus	Copper cable: 5 x RJ-45; Fiber optic: 2 x SFP-slots (e.g., with SFP module and LC fiber-optic connector)
Ambient temperature (operation)	-40 ... +70 °C (per CE); -10 ... +60 °C per UL 61010
Dimensions W x H x D	(50 x 160 x 120) mm
Approvals	CE; OrdLoc
For data sheet and additional information, see:	wago.com/852-1417

Standard Unmanaged ▶ 5 ports 100BASE-TX



852-101

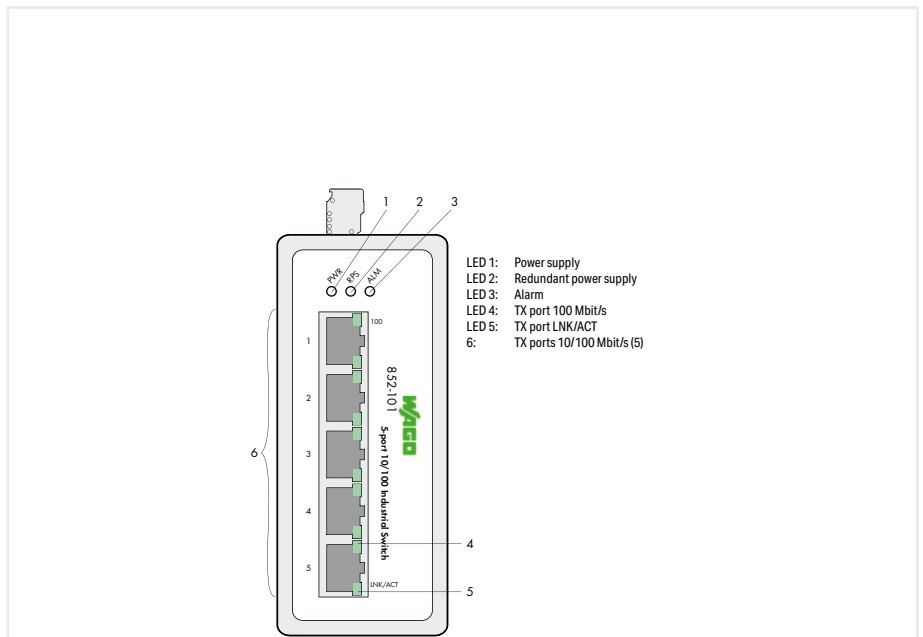

Item no.

852-101

Order Text

Industrial-Switch; 5Port

Technical data

Switching mode	Store-and-forward; non-blocking
Number of copper ports	5 x 100BASE-TX (RJ-45)
Communication standards	IEEE 802.3 10BASE-T; IEEE 802.3u 100BASE-TX; IEEE 802.3x Flow Control
Redundancy function	Redundant DC power supply
Configuration options	DIP switch for signal contact
Diagnostics	Signal contact
MAC table (size)	2000 addresses
Jumbo frame size	1536 bytes
Supply voltage	9 ... 48 VDC; Cable length: < 3 m
Power consumption (max.)	3.84 W
ESD (contact/air discharge)	8 KV / 15 KV
Connection technology: communication/fieldbus	Copper cable: 5 x RJ-45
Ambient temperature (operation)	-40 ... +70 °C (UL max. +60 °C)
Dimensions W x H x D	(50 x 105 x 120) mm
Approvals	CE, RoHS, OrdLoc

For data sheet and additional information, see:

wago.com/852-101

Standard Unmanaged ► 8 ports 100BASE-TX



852-102

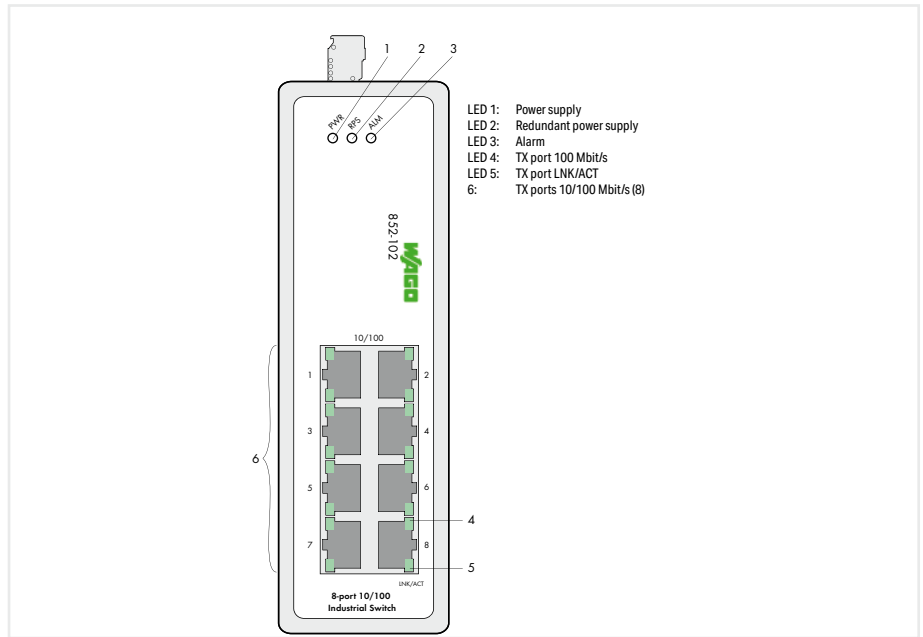

Item no.	852-102
Order Text	Industrial-Switch; 8Port

Technical data	
Switching mode	Store-and-forward; non-blocking
Number of copper ports	8 x 100BASE-TX (RJ-45)
Communication standards	IEEE 802.3 10BASE-T; IEEE 802.3u 100BASE-TX; IEEE 802.3x Flow Control
Redundancy function	Redundant DC power supply
Configuration options	DIP switch for signal contact
Diagnostics	Signal contact
MAC table (size)	2000 addresses
Jumbo frame size	1536 bytes
Supply voltage	9 ... 48 VDC; Cable length:< 3 m
Power consumption (max.)	5.28 W
ESD (contact/air discharge)	8 KV / 15 KV
Connection technology: communication/fieldbus	Copper cable: 8 x RJ-45
Ambient temperature (operation)	-40 ... +70 °C (UL max. +60 °C)
Dimensions W x H x D	(50 x 162 x 120) mm
Approvals	CE, RoHS, OrdLoc

For data sheet and additional information, see:

wago.com/852-102

Standard Unmanaged ▶ 8 ports 100BASE-TX; 2 slots 100BASE-FX



852-103

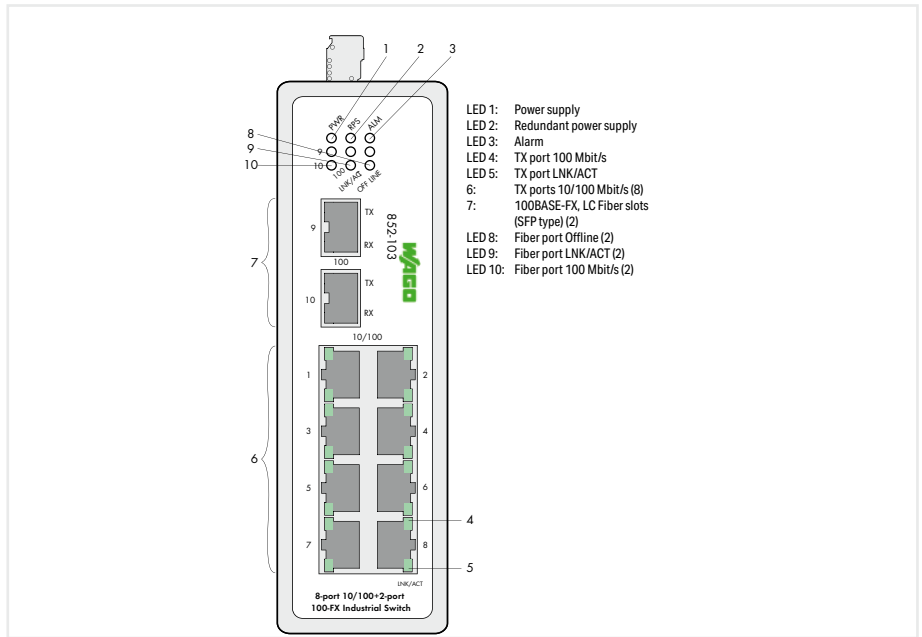

Item no.
Order Text

852-103
Industrial-Switch; 8Port; 2-Slot 100BASE-FX

Technical data	
Switching mode	Store-and-forward; non-blocking
Number of copper ports	8 x 100BASE-TX (RJ-45)
Number of FOC ports	2 x 100BASE-FX (SFP slot)
Communication standards	IEEE 802.3 10BASE-T; IEEE 802.3u 100BASE-TX/FX; IEEE 802.3x Flow Control
Redundancy function	Redundant DC power supply
Configuration options	DIP switch for signal contact
Diagnostics	Signal contact
MAC table (size)	2000 addresses
Jumbo frame size	1536 bytes
Supply voltage	9 ... 48 VDC; Cable length: < 3 m
Power consumption (max.)	6.08 W
ESD (contact/air discharge)	8 KV / 15 KV
Connection technology: communication/fieldbus	Copper cable: 8 x RJ-45; Fiber optic: 2 x SFP-slots (e.g., with SFP module and LC fiber-optic connector)
Ambient temperature (operation)	-40 ... +70 °C (UL max. +60 °C)
Dimensions W x H x D	(50 x 162 x 120) mm
Approvals	CE, RoHS, OrdLoc
For data sheet and additional information, see:	wago.com/852-103

Accessories

Item no.	
SFP Module 100BASE; FX Multi-Mode 1310 nm LC; 2 km; silver-colored	852-201/107-002
SFP Module 100BASE; LX Single-Mode 1310 nm LC; 30 km; silver-colored	852-201/107-030

10

Standard Unmanaged ▶ 8 ports 1000BASE-T



852-1102

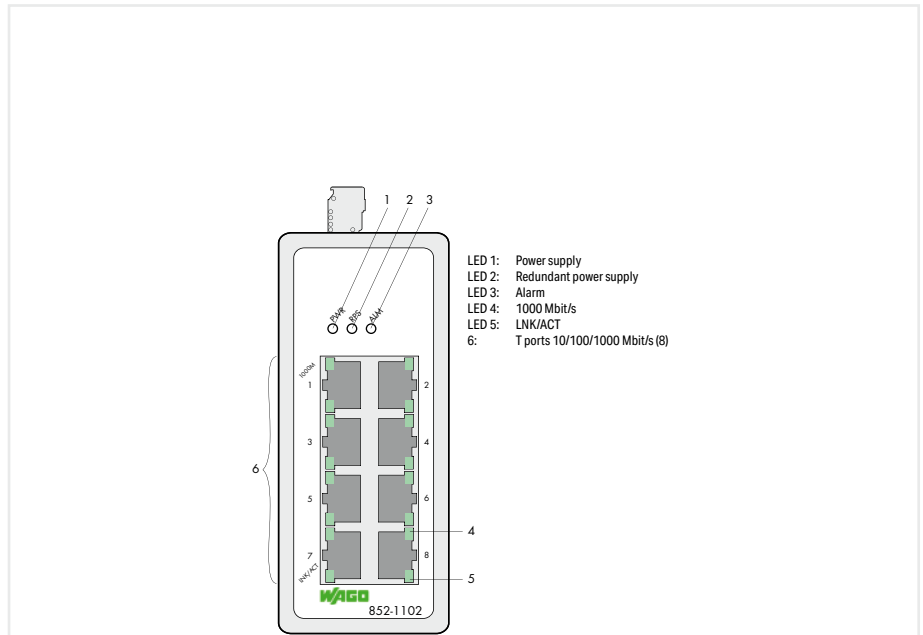

Item no.	852-1102
Order Text	Industrial-Switch; 8-Port Gb

Technical data	
Switching mode	Store-and-forward; non-blocking
Number of copper ports	8 x 1000BASE-T or 100BASE-TX (RJ-45)
Communication standards	IEEE 802.3 10BASE-T; IEEE 802.3u 100BASE-TX; IEEE 802.3ab 1000BASE-T; IEEE 802.3x Flow Control; IEEE 802.3az Energy Efficient Ethernet; IEEE 802.1p Prioritization
Redundancy function	Redundant DC power supply
Configuration options	DIP switch for signal contact
Diagnostics	Signal contact
MAC table (size)	8000 addresses
Jumbo frame size	9000 bytes
Supply voltage	9 ... 57 VDC
Power consumption (max.)	6 W
ESD (contact/air discharge)	8 KV / 15 KV
Connection technology: communication/fieldbus	Copper cable: 8 x RJ-45
Ambient temperature (operation)	-40 ... +70 °C
Dimensions W x H x D	(50 x 105 x 120) mm
Approvals	CE; DNV GL; OrdLoc
For data sheet and additional information, see:	wago.com/852-1102

Standard Unmanaged ▶ 16 ports 1000BASE-T



852-1106

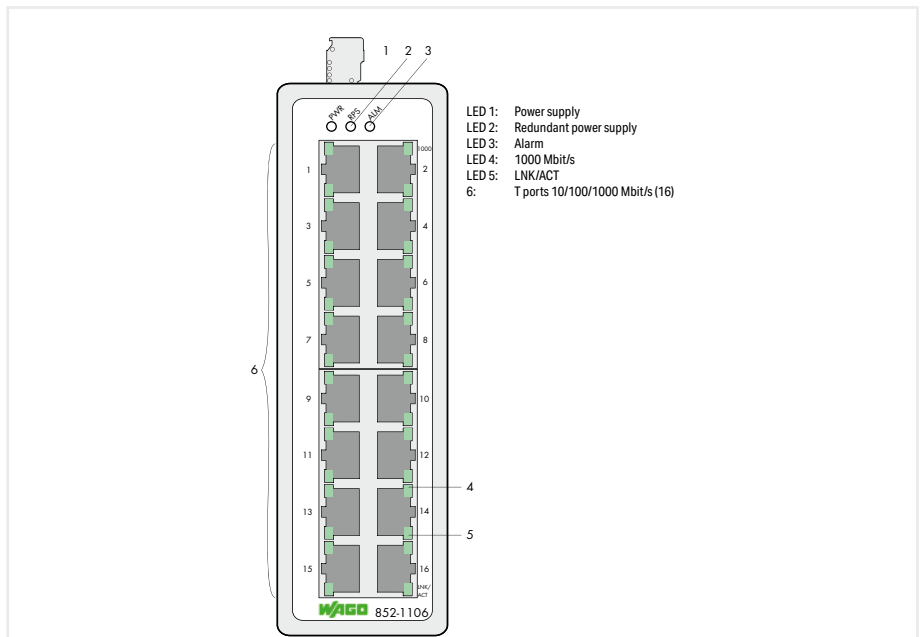

Item no.	852-1106
Order Text	Industrial-Switch; 16-Port Gb

Item no.	852-1106
Order Text	Industrial-Switch; 16-Port Gb

Technical data	
Switching mode	Store-and-forward; non-blocking
Number of copper ports	16 x 1000BASE-T or 100BASE-TX (RJ-45)
Communication standards	IEEE 802.3 10BASE-T; IEEE 802.3u 100BASE-TX/FX; IEEE 802.3ab 1000BASE-T; IEEE 802.3x Flow Control; IEEE 802.3az Energy Efficient Ethernet; IEEE 802.1p Prioritization
Redundancy function	Redundant DC power supply
Configuration options	DIP switch for signal contact
Diagnostics	Signal contact
MAC table (size)	8000 addresses
Jumbo frame size	10000 bytes
Supply voltage	12 ... 60 VDC
Power consumption (max.)	12 W
Connection technology: communication/fieldbus	Copper cable: 16 x RJ-45
Ambient temperature (operation)	-40 ... +70 °C
Dimensions W x H x D	(50 x 162 x 120) mm
Approvals	CE; DNV GL; OrdLoc
For data sheet and additional information, see:	wago.com/852-1106

Lean Managed ▶ 8 ports 1000BASE-T



852-1812

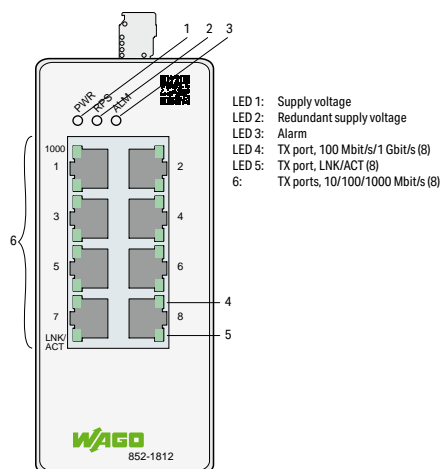

Item no.	852-1812
Order Text	Lean-Managed-Switch; 8-Port 1000BASE-T
Technical data	
Switching mode	Store-and-forward; non-blocking
Number of copper ports	8 x 1000BASE-T or 100BASE-TX (RJ-45)
Communication standards	IEEE 802.3 10BASE-T; IEEE 802.3u 100BASE-TX/FX; IEEE 802.3ab 1000BASE-T; IEEE 802.3x Flow Control; IEEE 802.1d Spanning Tree Protocol (STP); IEEE 802.1w Rapid Spanning Tree Protocol (RSTP); IEEE 802.1Q VLAN Tagging; IEEE 802.1p Prioritization; IEEE 802.1X Port Authentication; IEEE 802.1ab Link Layer Discovery Protocol (LLDP); IEEE 802.3az Energy Efficient Ethernet; ITU-T G8032v1/v2 Ethernet Ring Protection Switching (ERPS)
Redundancy function	Redundant DC power supply; STP; RSTP; ERPSv1/v2 (max. 2 rings per switch, max. 16 switches per ring, switching time < 800 ms)
Configuration options	DIP switch for signal contact; Web-Based Management; Command Line Interface; SNMPv1/v2c/v3
Diagnostics	Signal contact; Modbus TCP; port status; port statistics; port load; traffic monitor; syslog; SNMP traps; loop detection; diagnostics dashboard; topology map
Safety	Access-control list with max. 32 entries; port security; IEEE 802.1X authentication
MAC table (size)	8000 addresses
Jumbo frame size	10000 bytes
Supply voltage	24 ... 48 VDC; (±15 %); 24 ... 48 VDC (UL)
Power consumption (max.)	10 W
ESD (contact/air discharge)	8 KV / 15 KV
Connection technology: communication/fieldbus	Copper cable: 8 x RJ-45
Ambient temperature (operation)	-40 ... +60 °C
Dimensions W x H x D	(50 x 116 x 100) mm
Approvals	CE; - OrdLoc
For data sheet and additional information, see:	wago.com/852-1812

Lean Managed ▶ 8 ports 1000BASE-T; 2 slots 1000BASE-FX/TX



852-1813

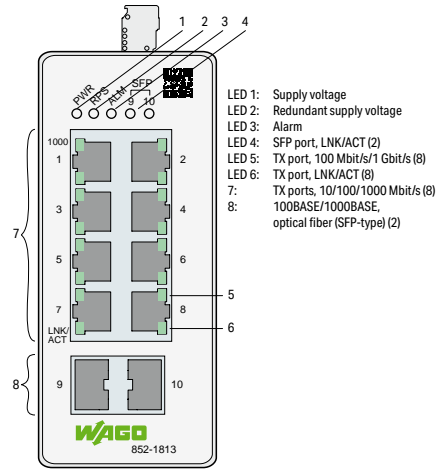

Item no.	852-1813
Order Text	Lean-Managed-Switch; 8-Port 1000BASE-T; 2 Slots 1000BASE-SX/LX
Technical data	
Switching mode	Store-and-forward; non-blocking
Number of copper ports	8 x 1000BASE-T or 100BASE-TX (RJ-45)
Number of FOC ports	2 x 1000BASE-SX/LX/ZX or 100BASE-FX (SFP slot)
Communication standards	IEEE 802.3 10BASE-T; IEEE 802.3u 100BASE-TX/FX; IEEE 802.3ab 1000BASE-T; IEEE 802.3z 1000BASE-SX/LX; IEEE 802.3x Flow Control; IEEE 802.1d Spanning Tree Protocol (STP); IEEE 802.1w Rapid Spanning Tree Protocol (RSTP); IEEE 802.1Q VLAN Tagging; IEEE 802.1p Prioritization; IEEE 802.1X Port Authentication; IEEE 802.1ab Link Layer Discovery Protocol (LLDP); IEEE 802.3az Energy Efficient Ethernet; ITU-T G8032v1/v2 Ethernet Ring Protection Switching (ERPS)
Redundancy function	Redundant DC power supply; STP; RSTP; ERPSv1/v2 (max. 2 rings per switch, max. 16 switches per ring, switching time < 800 ms)
Configuration options	DIP switch for signal contact; Web-Based Management; Command Line Interface; SNMPv1/v2c/v3
Diagnostics	Signal contact; Modbus TCP; port status; port statistics; port load; traffic monitor; syslog; SNMP traps; loop detection; diagnostics dashboard; topology map
Safety	Access-control list with max. 32 entries; port security; IEEE 802.1X authentication
MAC table (size)	8000 addresses
Jumbo frame size	10000 bytes
Supply voltage	24 ... 48 VDC; (± 15 %); 24 ... 48 VDC (UL)
Power consumption (max.)	11 W
ESD (contact/air discharge)	8 KV / 15 KV
Connection technology: communication/fieldbus	Copper cable: 8 x RJ-45; Fiber optic: 2 x SFP-slots (e.g., with SFP module and LC fiber-optic connector)
Ambient temperature (operation)	-40 ... +60 °C
Dimensions W x H x D	(50 x 116 x 100) mm
Approvals	CE; OrdLoc
For data sheet and additional information, see:	wago.com/852-1813
Accessories	
SFP Module 100BASE; FX Multi-Mode 1310 nm LC; 2 km; silver-colored	852-201/107-002
SFP Module 100BASE; LX Single-Mode 1310 nm LC; 30 km; silver-colored	852-201/107-030
SFP Module 1000BASE; ZX Single-Mode 1550 nm LC; 80 km; Extended temperature range; Digital Diagnostics Monitoring; silver-colored	852-1280
SFP Module 1000BASE; SX Multi-Mode 850 nm LC; 0.55 km; Extended temperature range; DDM; silver-colored	852-1200
SFP Module 1000BASE; LX Single-Mode 1310 nm LC; 10 km; Extended temperature range; Digital Diagnostics Monitoring; silver-colored	852-1210

Lean Managed ▶ 8 ports 1000BASE-T; 2 slots 1000BASE-FX/TX; 8 * Power over Ethernet



852-1813/000-001

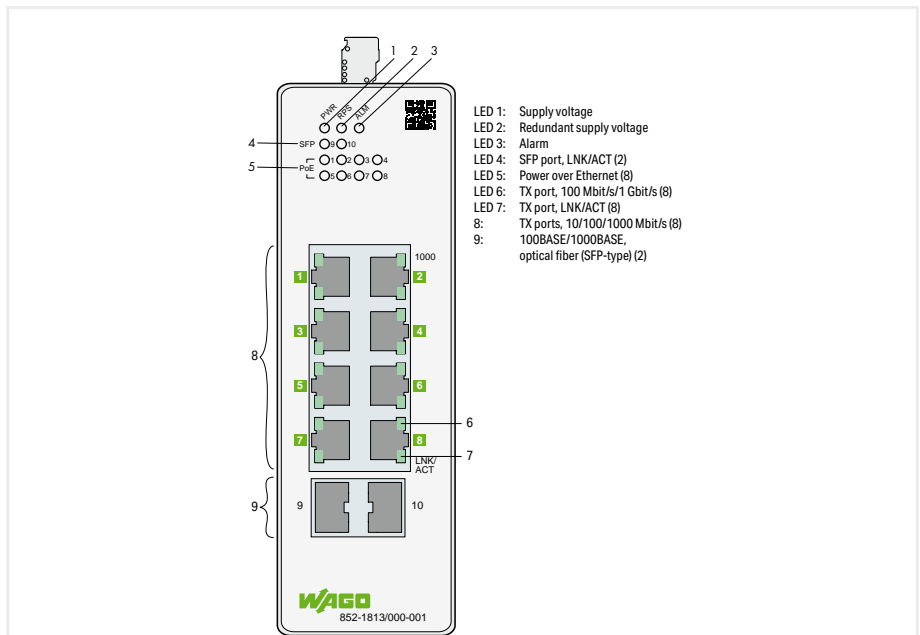

Item no.	852-1813/000-001
Order Text	Lean-Managed-Switch; 8-Port 1000BASE-T; 2 Slots 1000BASE-SX/LX; +PoE

Technical data	
Switching mode	Store-and-forward; non-blocking
Number of copper ports	8 x 1000BASE-T or 100BASE-TX (RJ-45); 8 x PoE+ (Power over Ethernet)
Number of FOC ports	2 x 1000BASE-SX/LX/ZX or 100BASE-FX (SFP slot)
Communication standards	IEEE 802.3 10BASE-T; IEEE 802.3u 100BASE-TX/FX; IEEE 802.3ab 1000BASE-T; IEEE 802.3x Flow Control; IEEE 802.1d Spanning Tree Protocol (STP); IEEE 802.1w Rapid Spanning Tree Protocol (RSTP); IEEE 802.1Q VLAN Tagging; IEEE 802.1p Prioritization; IEEE 802.1X Port Authentication; IEEE 802.1ab Link Layer Discovery Protocol (LLDP); IEEE 802.3af Power over Ethernet (PoE); IEEE 802.3at High Power over Ethernet (PoE+); IEEE 802.3az Energy Efficient Ethernet; ITU-T G8032v1/v2 Ethernet Ring Protection Switching (ERPS)
Redundancy function	Redundant DC power supply; STP; RSTP; ERPSv1/v2 (max. 2 rings per switch, max. 16 switches per ring, switching time < 800 ms)
Configuration options	DIP switch for signal contact; Web-Based Management; Command Line Interface; SNMPv1/v2c/v3
Diagnostics	Signal contact; Modbus TCP; port status; port statistics; port load; traffic monitor; syslog; SNMP traps; loop detection; diagnostics dashboard; topology map
Safety	Access-control list with max. 32 entries; port security; IEEE 802.1X authentication
MAC table (size)	8000 addresses
Jumbo frame size	10000 bytes
Supply voltage	24 ... 57 VDC
Power consumption (max.)	13 W
Power consumption (note)	253 W with 8 PoE+; 30 W per port
ESD (contact/air discharge)	8 KV / 15 KV
Connection technology: communication/fieldbus	Copper cable: 8 x RJ-45; Fiber optic: 2 x SFP-slots (e.g., with SFP module and LC fiber-optic connector)
Ambient temperature (operation)	-40 ... +60 °C
Dimensions W x H x D	(50 x 160 x 120) mm
Approvals	CE; OrdLoc
For data sheet and additional information, see:	wago.com/852-1813/000-001

Accessories	
SFP Module 100BASE; FX Multi-Mode 1310 nm LC; 2 km; silver-colored	852-201/107-002
SFP Module 100BASE; LX Single-Mode 1310 nm LC; 30 km; silver-colored	852-201/107-030
SFP Module 1000BASE; ZX Single-Mode 1550 nm LC; 80 km; Extended temperature range; Digital Diagnostics Monitoring; silver-colored	852-1280
SFP Module 1000BASE; SX Multi-Mode 850 nm LC; 0.55 km; Extended temperature range; DDM; silver-colored	852-1200
SFP Module 1000BASE; LX Single-Mode 1310 nm LC; 10 km; Extended temperature range; Digital Diagnostics Monitoring; silver-colored	852-1210

10

Lean Managed ▶ 16 ports 1000BASE-T



852-1816

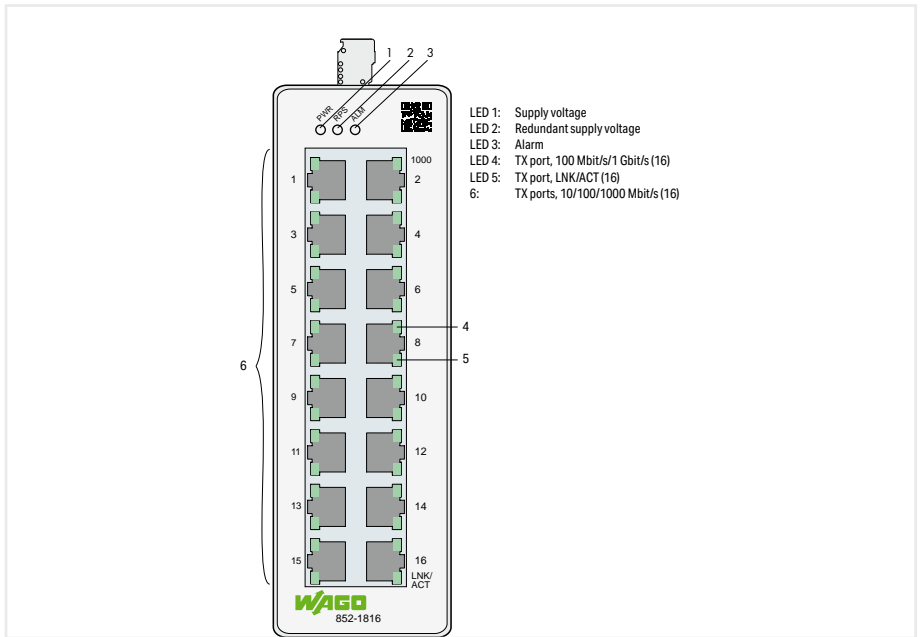

Item no.	852-1816
Order Text	Lean-Managed-Switch; 16 Ports 1000BASE-T
Technical data	
Switching mode	Store-and-forward; non-blocking
Number of copper ports	16 x 1000BASE-T or 100BASE-TX (RJ-45)
Communication standards	IEEE 802.3 10BASE-T; IEEE 802.3u 100BASE-TX/FX; IEEE 802.3ab 1000BASE-T; IEEE 802.3x Flow Control; IEEE 802.1d Spanning Tree Protocol (STP); IEEE 802.1w Rapid Spanning Tree Protocol (RSTP); IEEE 802.1Q VLAN Tagging; IEEE 802.1p Prioritization; IEEE 802.1X Port Authentication; IEEE 802.1ab Link Layer Discovery Protocol (LLDP); IEEE 802.3az Energy Efficient Ethernet; ITU-T G8032v1/v2 Ethernet Ring Protection Switching (ERPS)
Redundancy function	Redundant DC power supply; STP; RSTP; ERPSv1/v2 (max. 2 rings per switch, max. 16 switches per ring, switching time < 800 ms)
Configuration options	DIP switch for signal contact; Web-Based Management; Command Line Interface; SNMPv1/v2c/v3
Diagnostics	Signal contact; Modbus TCP; port status; port statistics; port load; traffic monitor; syslog; SNMP traps; loop detection; diagnostics dashboard; topology map
Safety	Access-control list with max. 32 entries; port security; IEEE 802.1X authentication
MAC table (size)	8000 addresses
Jumbo frame size	10000 bytes
Supply voltage	12 ... 60 VDC
Power consumption (max.)	12 W
ESD (contact/air discharge)	8 KV / 15 KV
Connection technology: communication/fieldbus	Copper cable: 16 x RJ-45
Ambient temperature (operation)	-40 ... +60 °C
Dimensions W x H x D	(50 x 160 x 120) mm
Approvals	CE; - OrdLoc
For data sheet and additional information, see:	wago.com/852-1816

MACsec Managed ▶ 8 ports 1000BASE-T; MAC security



852-1322

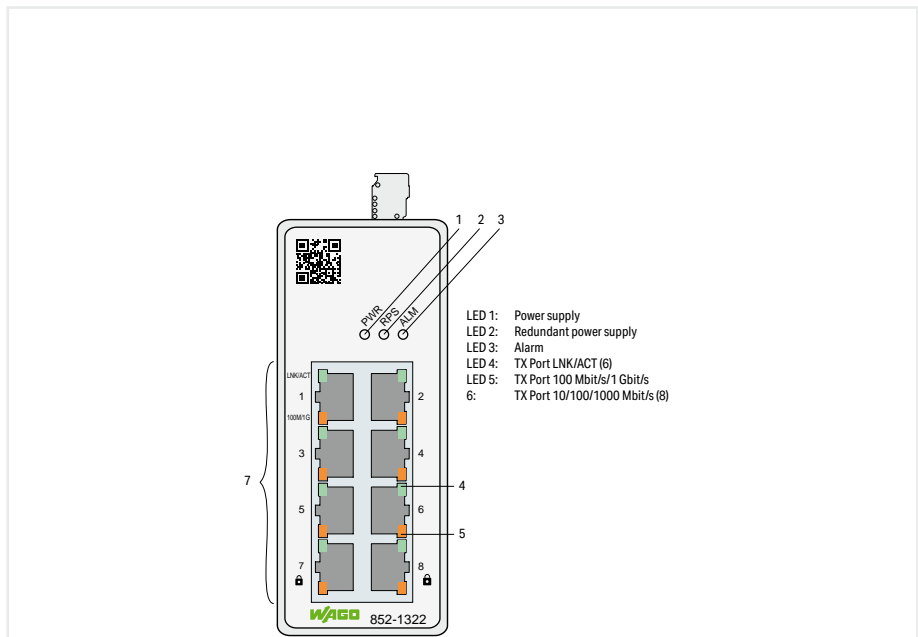

Item no.	852-1322
Order Text	Managed Switch; 8Port Gb; MACsec
Technical data	
Switching mode	Store-and-forward; non-blocking
Number of copper ports	8 x 1000BASE-T or 100BASE-TX (RJ-45)
Communication standards	IEEE 802.3 10BASE-T; IEEE 802.3u 100BASE-TX; IEEE 802.3ab 1000BASE-T; IEEE 802.3x Flow Control; IEEE 802.1p Prioritization; IEEE 802.1X Port Authentication; IEEE 802.1Q VLAN Tagging; IEEE 802.1AE MAC Security
Redundancy function	Redundant DC power supply
Configuration options	Web-based (HTTP(S)); SNMPv1/v2c/v3
Diagnostics	Modbus TCP; Port status; Syslog; SNMP traps
MAC table (size)	16000 addresses
Supply voltage	9 ... 48 VDC
Power consumption (max.)	5.8 W
ESD (contact/air discharge)	8 KV / 15 KV
Connection technology: communication/fieldbus	Copper cable: 8 x RJ-45
Ambient temperature (operation)	-20 ... +70 °C
Dimensions W x H x D	(45.3 x 110 x 92) mm
Approvals	CE; OrdLoc (E482462)
For data sheet and additional information, see:	wago.com/852-1322

MACsec Managed ▶ 6 ports 1000BASE-T; 2 slots 1000BASE-SX/LX; MAC security



852-1328

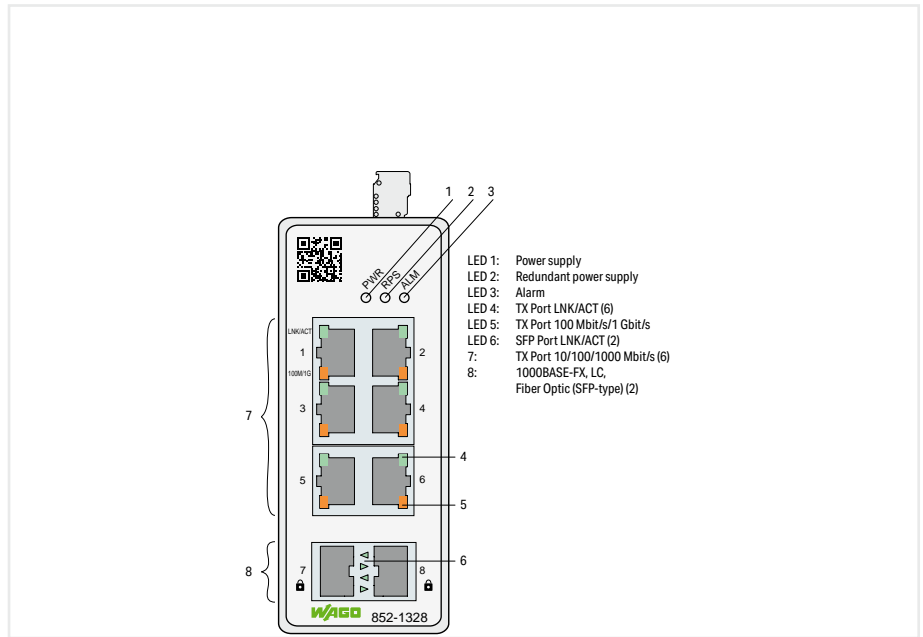

Item no.
Order Text

852-1328
Managed Switch; 6Port Gb; 2FOC Gb; MACsec

Technical data	
Switching mode	Store-and-forward; non-blocking
Number of copper ports	6 x 1000BASE-T or 100BASE-TX (RJ-45)
Number of FOC ports	2 x 1000BASE-SX/LX or 100BASE-FX (SFP slot)
Communication standards	IEEE 802.3 10BASE-T; IEEE 802.3u 100BASE-TX; IEEE 802.3ab 1000BASE-T; IEEE 802.3z 1000BASE-SX/LX; IEEE 802.3x Flow Control; IEEE 802.1p Prioritization; IEEE 802.1X Port Authentication; IEEE 802.1Q VLAN Tagging; IEEE 802.1AE MAC Security
Redundancy function	Redundant DC power supply
Configuration options	Web-based (HTTP(S)); SNMPv1/v2c/v3
Diagnostics	Modbus TCP; Port status; Syslog; SNMP traps
MAC table (size)	16000 addresses
Supply voltage	9 ... 48 VDC
Power consumption (max.)	5.8 W
ESD (contact/air discharge)	8 KV / 15 KV
Connection technology: communication/fieldbus	Copper cable: 6 x RJ-45; Fiber optic: 2 x SFP-slots (e.g., with SFP module and LC fiber-optic connector)
Ambient temperature (operation)	-20 ... +70 °C
Dimensions W x H x D	(45.3 x 110 x 92) mm
Approvals	CE; OrdLoc (E482462)
For data sheet and additional information, see:	wago.com/852-1328

Technical data	
Switching mode	Store-and-forward; non-blocking
Number of copper ports	6 x 1000BASE-T or 100BASE-TX (RJ-45)
Number of FOC ports	2 x 1000BASE-SX/LX or 100BASE-FX (SFP slot)
Communication standards	IEEE 802.3 10BASE-T; IEEE 802.3u 100BASE-TX; IEEE 802.3ab 1000BASE-T; IEEE 802.3z 1000BASE-SX/LX; IEEE 802.3x Flow Control; IEEE 802.1p Prioritization; IEEE 802.1X Port Authentication; IEEE 802.1Q VLAN Tagging; IEEE 802.1AE MAC Security
Redundancy function	Redundant DC power supply
Configuration options	Web-based (HTTP(S)); SNMPv1/v2c/v3
Diagnostics	Modbus TCP; Port status; Syslog; SNMP traps
MAC table (size)	16000 addresses
Supply voltage	9 ... 48 VDC
Power consumption (max.)	5.8 W
ESD (contact/air discharge)	8 KV / 15 KV
Connection technology: communication/fieldbus	Copper cable: 6 x RJ-45; Fiber optic: 2 x SFP-slots (e.g., with SFP module and LC fiber-optic connector)
Ambient temperature (operation)	-20 ... +70 °C
Dimensions W x H x D	(45.3 x 110 x 92) mm
Approvals	CE; OrdLoc (E482462)
For data sheet and additional information, see:	wago.com/852-1328

Accessories	
SFP Module 100BASE; FX Multi-Mode 1310 nm LC; 2 km; silver-colored	852-201/107-002
SFP Module 100BASE; LX Single-Mode 1310 nm LC; 30 km; silver-colored	852-201/107-030
SFP Module 1000BASE; ZX Single-Mode 1550 nm LC; 80 km; Extended temperature range; Digital Diagnostics Monitoring; silver-colored	852-1280
SFP Module 1000BASE; SX Multi-Mode 850 nm LC; 0.55 km; Extended temperature range; DDM; silver-colored	852-1200
SFP Module 1000BASE; LX Single-Mode 1310 nm LC; 10 km; Extended temperature range; Digital Diagnostics Monitoring; silver-colored	852-1210

Item no.	852-201/107-002
	852-201/107-030
	852-1280
	852-1200
	852-1210

Fully Managed ► 8 ports 100BASE-TX; 2 slots 1000BASE-SX/LX



852-303

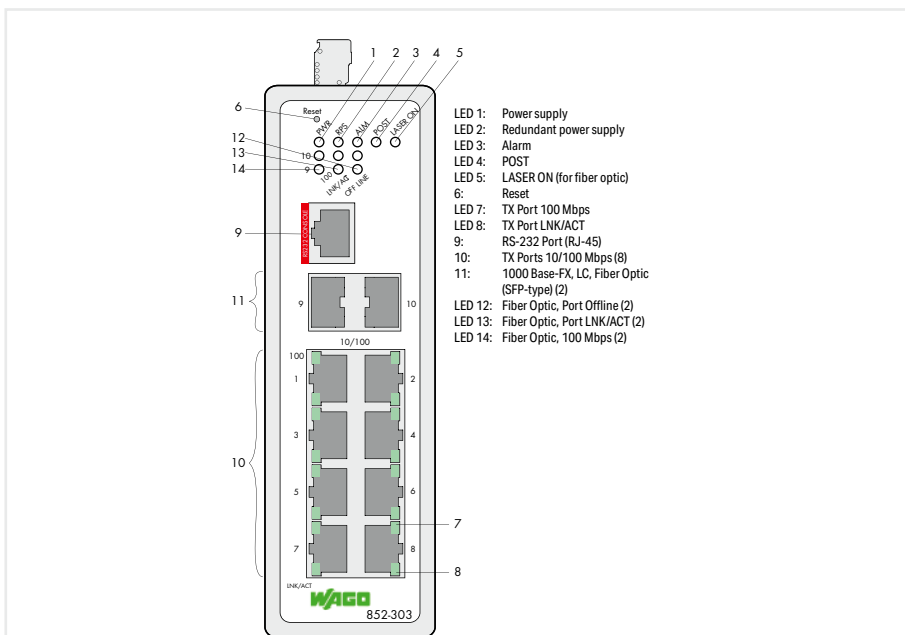

Item no.	852-303
Order Text	Managed-Switch; 8Port; 2-Slot 1000BASE-SX/LX
Technical data	
Switching mode	Store-and-forward; non-blocking
Number of copper ports	8 x 100BASE-TX (RJ-45)
Number of FOC ports	2 x 1000BASE-SX/LX or 100BASE-FX (SFP slot)
Communication standards	IEEE 802.3 10BASE-T; IEEE 802.3u 100BASE-TX/FX; IEEE 802.3z 1000BASE-SX/LX; IEEE 802.3x Flow Control; IEEE 802.1w Rapid Spanning Tree Protocol (RSTP); IEEE 802.1Q VLAN Tagging; IEEE 802.1ab Link Layer Discovery Protocol (LLDP); IEEE 802.1p Prioritization; IEEE 802.1X Port Authentication
Redundancy function	Redundant DC power supply; STP; RSTP; MSTP; Jet Ring < 300 ms; Xpress Ring < 20 ms; Dual Homing < 20 ms; Dual Ring; ERPSv2 < 50 ms; LCAP
Configuration options	DIP switch for signal contact; Command Line Interface; SNMPv1/v2c/v3
Diagnostics	Signal contact, Modbus/TCP, port status, port statistics, port load, traffic monitor, SFP information, syslog, mail alarm, SNMP traps
MAC table (size)	16000 addresses
Jumbo frame size	10000 bytes
Supply voltage	12 ... 60 VDC; Cable length: < 3 m
Power consumption (max.)	12 W
ESD (contact/air discharge)	8 KV / 15 KV
Connection technology: communication/fieldbus	Copper cable: 8 x RJ-45; Fiber optic: 2 x SFP-slots (e.g., with SFP module and LC fiber-optic connector)
Ambient temperature (operation)	-40 ... +70 °C
Dimensions W x H x D	(50 x 162 x 120) mm
Approvals	CE; DNV GL; OrdLoc
For data sheet and additional information, see:	wago.com/852-303
Accessories	
SFP Module 100BASE; FX Multi-Mode 1310 nm LC; 2 km; silver-colored	852-201/107-002
SFP Module 100BASE; LX Single-Mode 1310 nm LC; 30 km; silver-colored	852-201/107-030
SFP Module 1000BASE; ZX Single-Mode 1550 nm LC; 80 km; Extended temperature range; Digital Diagnostics Monitoring; silver-colored	852-1280
SFP Module 1000BASE; SX Multi-Mode 850 nm LC; 0.55 km; Extended temperature range; DDM; silver-colored	852-1200
SFP Module 1000BASE; LX Single-Mode 1310 nm LC; 10 km; Extended temperature range; Digital Diagnostics Monitoring; silver-colored	852-1210

Fully Managed ▶ 8 ports 1000BASE-T; 4 slots 1000BASE-SX/LX



852-1305

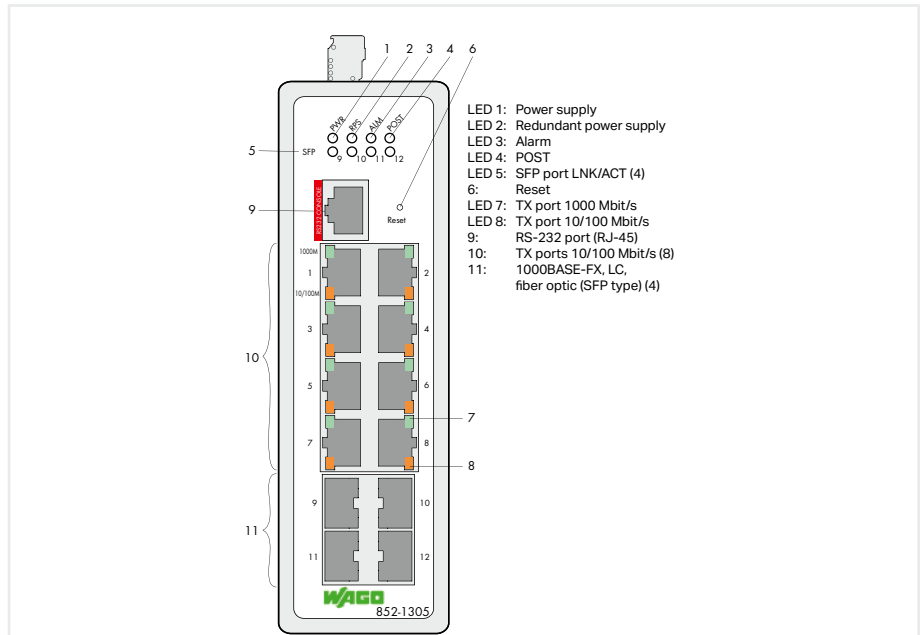

Item no.	852-1305
Order Text	Managed-Switch; 8-Port Gb; 4-Slot 1000BASE-SX/LX
Technical data	
Switching mode	Store-and-forward; non-blocking
Number of copper ports	8 x 1000BASE-T or 100BASE-TX (RJ-45)
Number of FOC ports	4 x 1000BASE-SX/LX (SFP slot)
Communication standards	IEEE 802.3 10BASE-T; IEEE 802.3u 100BASE-TX; IEEE 802.3ab 1000BASE-T; IEEE 802.3z 1000BASE-SX/LX; IEEE 802.3x Flow Control; IEEE 802.1w Rapid Spanning Tree Protocol (RSTP); IEEE 802.1Q VLAN Tagging; IEEE 802.1ab Link Layer Discovery Protocol (LLDP); IEEE 802.1p Prioritization; IEEE 802.1X Port Authentication; ITU-T G8032v1/v2 Ethernet Ring Protection Switching (ERPS)
Redundancy function	Redundant DC power supply; STP; RSTP; MSTP; Jet Ring < 300 ms; Xpress Ring < 20 ms; Dual Homing < 20 ms; Dual Ring; ERPSv2 < 50 ms; LCAP
Configuration options	DIP switch for signal contact; Command Line Interface; SNMPv1/v2c/v3
Diagnostics	Signal contact, Modbus/TCP, port status, port statistics, port load, traffic monitor, SFP information, syslog, mail alarm, SNMP traps
MAC table (size)	16000 addresses
Jumbo frame size	10000 bytes
Supply voltage	12 ... 60 VDC; Cable length:< 3 m
Power consumption (max.)	18 W
ESD (contact/air discharge)	8 KV / 15 KV
Connection technology: communication/fieldbus	Copper cable: 8 x RJ-45; Fiber optic: 4 x SFP-slots (e.g., with SFP module and LC fiber-optic connector)
Ambient temperature (operation)	-40 ... +70 °C
Dimensions W x H x D	(50 x 162 x 120) mm
Approvals	CE; DNV GL; Ⓢ OrdLoc
For data sheet and additional information, see:	wago.com/852-1305
Accessories	
SFP Module 1000BASE; ZX Single-Mode 1550 nm LC; 80 km; Extended temperature range; Digital Diagnostics Monitoring; silver-colored	852-1280
SFP Module 1000BASE; SX Multi-Mode 850 nm LC; 0.55 km; Extended temperature range; DDM; silver-colored	852-1200
SFP Module 1000BASE; LX Single-Mode 1310 nm LC; 10 km; Extended temperature range; Digital Diagnostics Monitoring; silver-colored	852-1210

Fully Managed ▶ 8 ports 1000BASE-T; 4 slots 1000BASESX/LX; USB



852-1305/000-001

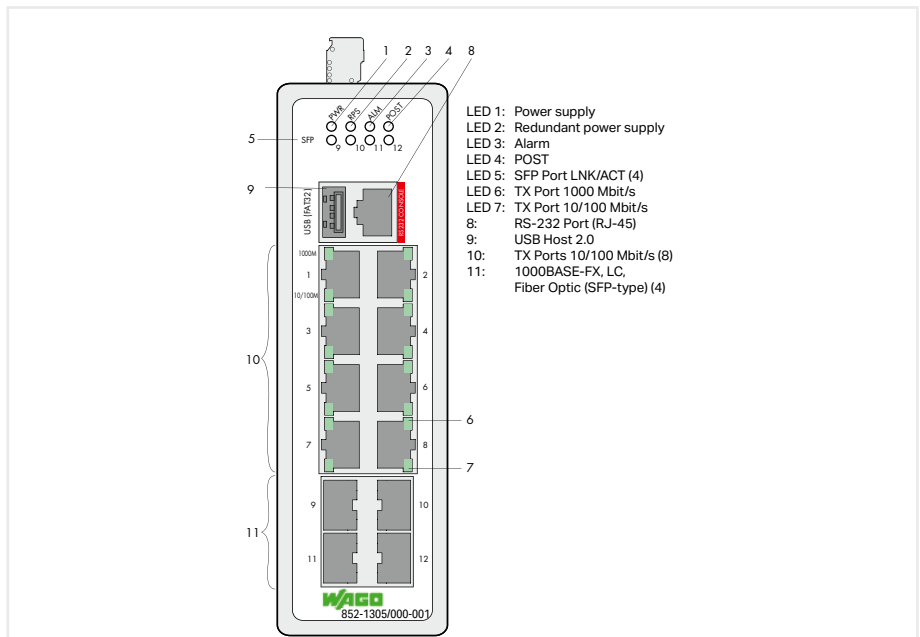

Item no.
Order Text

852-1305/000-001
Managed-Switch; 8Port 1000BASE-T; 4Slot 1000BASE-SX/LX; USB

Technical data
 Switching mode
 Number of copper ports
 Number of FOC ports
 Communication standards

Store-and-forward; non-blocking
 8 x 1000BASE-T or 100BASE-TX (RJ-45)
 4 x 1000BASE-SX/LX (SFP slot)
 IEEE 802.3 10BASE-T; IEEE 802.3u 100BASE-TX; IEEE 802.3ab 1000BASE-T; IEEE 802.3z 1000BASE-SX/LX; IEEE 802.3x Flow Control; IEEE 802.1d Spanning Tree Protocol (STP); IEEE 802.1w Rapid Spanning Tree Protocol (RSTP); IEEE 802.1s Multiple Spanning Tree Protocol (MSTP); IEEE 802.1Q VLAN Tagging; IEEE 802.1p Prioritization; IEEE 802.1X Port Authentication; IEEE 802.1ab Link Layer Discovery Protocol (LLDP); IEEE 802.3ad Link Aggregation; ITU-T G8032v1/v2 Ethernet Ring Protection Switching (ERPS)

Redundancy function

Redundant DC power supply; STP; RSTP; MSTP; Jet Ring < 300 ms; Xpress Ring < 20 ms; Dual Homing < 20 ms; Dual Ring; ERPSv2 < 50 ms; LCAP

Configuration options

DIP switch for signal contact; Web-Based Management; Command Line Interface; SNMPv1/v2c/v3; USB storage medium

Diagnostics

Signal contact; Modbus TCP; Port status; Port statistics; Port load; Traffic monitor; SFP information; Syslog; Mail alarm; SNMP traps; Loop detection; ...

MAC table (size)

16000 addresses

Jumbo frame size

10000 bytes

Supply voltage

12 ... 48 VDC

Power consumption (max.)

18 W

ESD (contact/air discharge)

8 KV / 15 KV

Connection technology: communication/fieldbus

Copper cable: 8 x RJ-45; Fiber optic: 4 x SFP-slots (e.g., with SFP module and LC fiber-optic connector)

Ambient temperature (operation)

-40 ... +70 °C

Dimensions W x H x D

(50 x 162 x 120) mm

Approvals

CE, OrdLoc

For data sheet and additional information, see:

wago.com/852-1305/000-001

Accessories
 SFP Module 1000BASE; ZX Single-Mode 1550 nm LC; 80 km; Extended temperature range; Digital Diagnostics Monitoring; silver-colored
 SFP Module 1000BASE; SX Multi-Mode 850 nm LC; 0.55 km; Extended temperature range; DDM; silver-colored
 SFP Module 1000BASE; LX Single-Mode 1310 nm LC; 10 km; Extended temperature range; Digital Diagnostics Monitoring; silver-colored

Item no.	852-1280
	852-1200
	852-1210

10

Fully Managed ▶ 8 ports 1000BASE-T; 4 slots 1000BASE-SX/LX; 8 * Power over Ethernet



852-1505

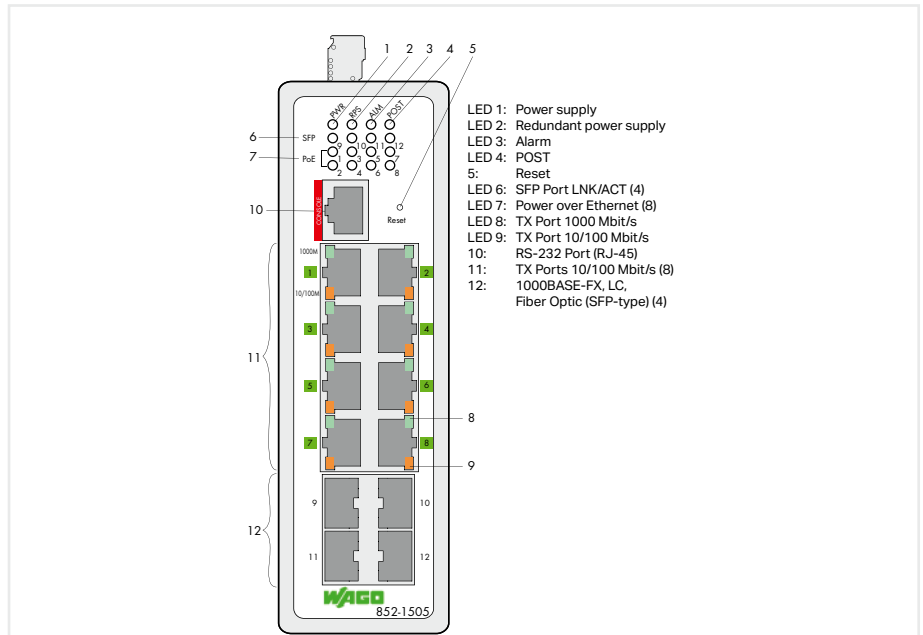

Item no.
Order Text

852-1505
Managed-Switch; 8-Port Gb; 4-Slot 1000BASE-SX/LX; 8PoE

Technical data

Switching mode
Number of copper ports
Number of FOC ports
Communication standards

Store-and-forward; non-blocking
8 x 1000BASE-T or 100BASE-TX (RJ-45); 8 x PoE+ (Power over Ethernet)
4 x 1000BASE-SX/LX (SFP slot)
IEEE 802.3 10BASE-T; IEEE 802.3u 100BASE-TX; IEEE 802.3ab 1000BASE-T; IEEE 802.3z 1000BASE-SX/LX; IEEE 802.3ad Port Trunk with LACP; IEEE 802.3x Flow Control; IEEE 802.1d Spanning Tree Protocol (STP); IEEE 802.1w Rapid Spanning Tree Protocol (RSTP); IEEE 802.1s Multiple Spanning Tree Protocol (MSTP); IEEE 802.1Q VLAN Tagging; IEEE 802.1p Prioritization; IEEE 802.1X Port Authentication; IEEE 802.1ab Link Layer Discovery Protocol (LLDP); IEEE 1588v2 Precision Time Protocol (PTP); IEEE 802.3af Power over Ethernet (PoE); IEEE 802.3at High Power over Ethernet (PoE+); ITU-T G8032v1/v2 Ethernet Ring Protection Switching (ERPS)

Redundancy function

Redundant DC power supply; STP; RSTP; MSTP; Jet Ring < 300 ms; Xpress Ring < 20 ms; Dual Homing < 20 ms; Dual Ring; ERPSv2 < 50 ms; LCAP

Configuration options

Diagnostics

DIP switch for signal contact; Command Line Interface; SNMPv1/v2c/v3
Signal contact, Modbus/TCP, port status, port statistics, port load, traffic monitor, SFP information, syslog, mail alarm, SNMP traps

MAC table (size)

16000 addresses

Jumbo frame size

10000 bytes

Supply voltage

48 ... 57 VDC

Power consumption (max.)

18 W

Power consumption (note)

258 W with 8 PoE+

ESD (contact/air discharge)

8 KV / 15 KV

Connection technology: communication/fieldbus

Copper cable: 8 x RJ-45; Fiber optic: 4 x SFP-slots (e.g., with SFP module and LC fiber-optic connector)

Ambient temperature (operation)

-40 ... +70 °C

Dimensions W x H x D

(50 x 162 x 120) mm

Approvals

CE

For data sheet and additional information, see:

wago.com/852-1505

Accessories

SFP Module 1000BASE; ZX Single-Mode 1550 nm LC; 80 km; Extended temperature range; Digital Diagnostics Monitoring; silver-colored

852-1280

SFP Module 1000BASE; SX Multi-Mode 850 nm LC; 0.55 km; Extended temperature range; DDM; silver-colored

852-1200

SFP Module 1000BASE; LX Single-Mode 1310 nm LC; 10 km; Extended temperature range; Digital Diagnostics Monitoring; silver-colored

852-1210

Fully Managed ▶ 8 ports 1000BASE-T; 4 slots 1000BASESX/LX; 8 * Power over Ethernet; USB



852-1505/000-001

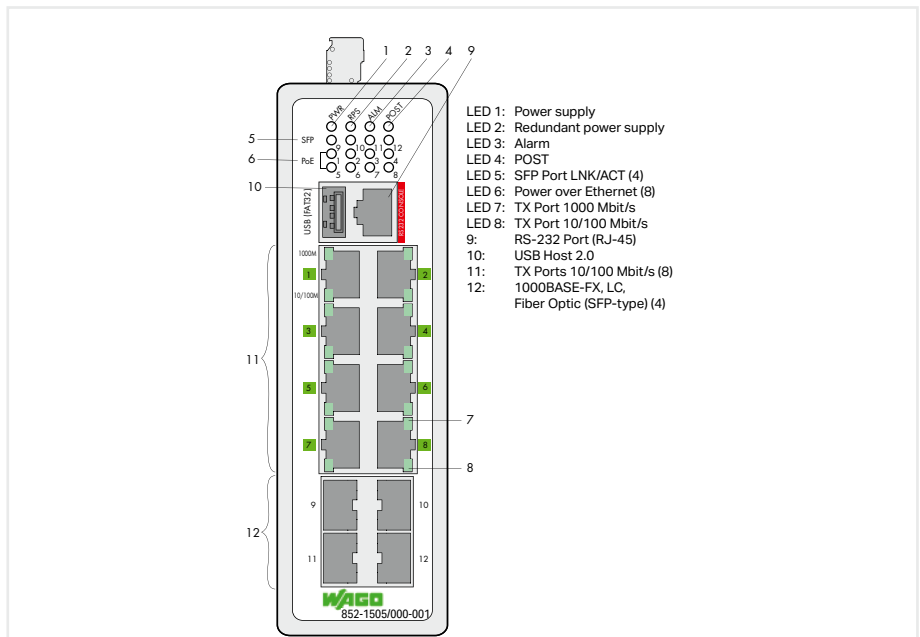

Item no.
Order Text

852-1505/000-001
Managed-Switch; 8Port 1000BASE-T; 4Slot 1000BASE-SX/LX; EXT; 8PoE; USB

Technical data
Switching mode
Number of copper ports
Number of FOC ports
Communication standards

Store-and-forward; non-blocking
8 x 1000BASE-T or 100BASE-TX (RJ-45); 8 x PoE+ (Power over Ethernet)
4 x 1000BASE-SX/LX (SFP slot)
IEEE 802.3 10BASE-T; IEEE 802.3u 100BASE-TX; IEEE 802.3ab 1000BASE-T; IEEE 802.3z 1000BASE-SX/LX; IEEE 802.3x Flow Control; IEEE 802.1d Spanning Tree Protocol (STP); IEEE 802.1w Rapid Spanning Tree Protocol (RSTP); IEEE 802.1s Multiple Spanning Tree Protocol (MSTP); IEEE 802.1Q VLAN Tagging; IEEE 802.1p Prioritization; IEEE 802.1X Port Authentication; IEEE 802.1ab Link Layer Discovery Protocol (LLDP); IEEE 802.3ad Link Aggregation; IEEE 802.3af Power over Ethernet (PoE); IEEE 802.3at High Power over Ethernet (PoE+); ITU-T G8032v1/v2 Ethernet Ring Protection Switching (ERPS)

Redundancy function

Redundant DC power supply; STP; RSTP; MSTP; Jet Ring < 300 ms; Xpress Ring < 20 ms; Dual Homing < 20 ms; Dual Ring; ERPSv2 < 50 ms; LCAP
--

Configuration options

DIP switch for signal contact; Web-Based Management; Command Line Interface; SNMPv1/v2c/v3; USB storage medium
--

Diagnostics

Signal contact; Modbus TCP; Port status; Port statistics; Port load; Traffic monitor; SFP information; Syslog; Mail alarm; SNMP traps; Loop detection; ...
--

MAC table (size)

16000 addresses

Jumbo frame size

10000 bytes

Supply voltage

24 ... 57 VDC

Power consumption (max.)

18 W

Power consumption (note)

258 W with 8 PoE+

ESD (contact/air discharge)

8 KV / 15 KV

Connection technology: communication/fieldbus

Copper cable: 8 x RJ-45; Fiber optic: 4 x SFP-slots (e.g., with SFP module and LC fiber-optic connector)
--

Ambient temperature (operation)

-40 ... +70 °C

Dimensions W x H x D

(50 x 162 x 120) mm

Approvals

CE; DNV GL; OrdLoc

For data sheet and additional information, see:

wago.com/852-1505/000-001

Accessories

SFP Module 1000BASE; ZX Single-Mode 1550 nm LC; 80 km; Extended temperature range; Digital Diagnostics Monitoring; silver-colored

Item no.	852-1280
-----------------	----------

SFP Module 1000BASE; SX Multi-Mode 850 nm LC; 0.55 km; Extended temperature range; DDM; silver-colored

	852-1200
--	----------

SFP Module 1000BASE; LX Single-Mode 1310 nm LC; 10 km; Extended temperature range; Digital Diagnostics Monitoring; silver-colored

	852-1210
--	----------

10

PROFINET® Managed ▶ 8 ports 100BASE-TX; PROFINET



852-602

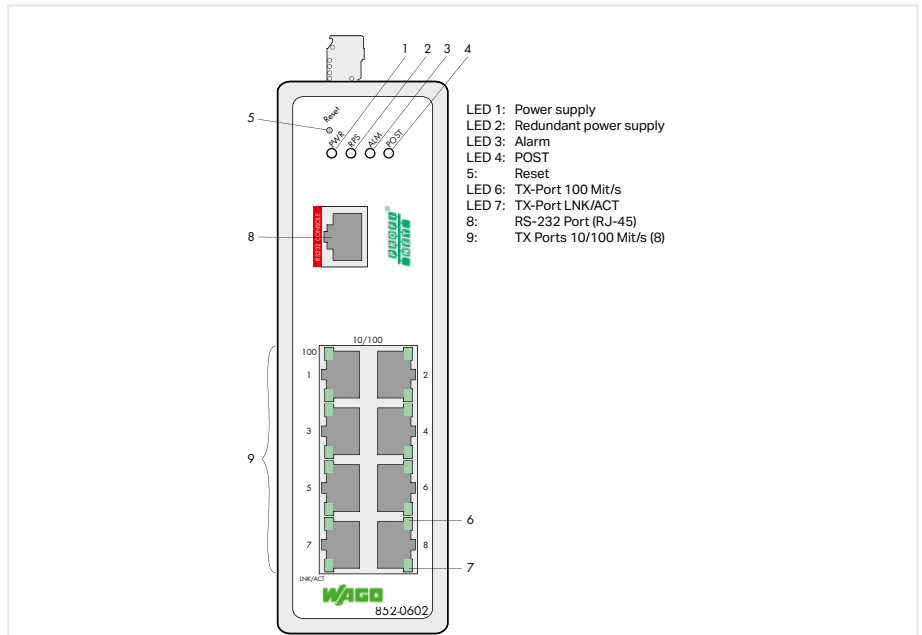

Item no.	852-602
Order Text	Managed-Switch; 8Port 100BASE-TX; PROFINET; T
Technical data	
Switching mode	Store-and-forward; non-blocking
Number of copper ports	8 x 100BASE-TX (RJ-45)
Communication standards	IEEE 802.3 10BASE-T; IEEE 802.3u 100BASE-TX; IEEE 802.3x Flow Control; IEEE 802.1d Spanning Tree Protocol (STP); IEEE 802.1w Rapid Spanning Tree Protocol (RSTP); IEEE 802.1s Multiple Spanning Tree Protocol (MSTP); IEEE 802.1Q VLAN Tagging; IEEE 802.1p Class of Service; IEEE 802.1ab Link Layer Discovery Protocol (LLDP); PROFINET Conformance Class B
Redundancy function	Redundant DC power supply; STP; RSTP; MSTP; Media redundancy protocol as manager or client
Configuration options	DIP switch for signal contact; Web-Based Management; Command Line Interface; SNMPv1/v2c/v3
Diagnostics	Signal contact; Port status; Port statistics; Port load; Traffic monitor; SFP information; Syslog; SNMP traps; PN diagnostics (cyclic and acyclic)
MAC table (size)	16000 addresses
Jumbo frame size	10000 bytes
Supply voltage	12 ... 60 VDC
Power consumption (max.)	12 W
ESD (contact/air discharge)	8 KV / 15 KV
Connection technology: communication/fieldbus	Copper cable: 8 x RJ-45
Ambient temperature (operation)	-40 ... +70 °C
Dimensions W x H x D	(50 x 162 x 120) mm
Approvals	CE; OrdLoc
For data sheet and additional information, see:	wago.com/852-602

PROFINET® Managed ▶ 8 ports 100BASE-TX; 2 slots 1000BASE-SX/LX; PROFINET



852-603

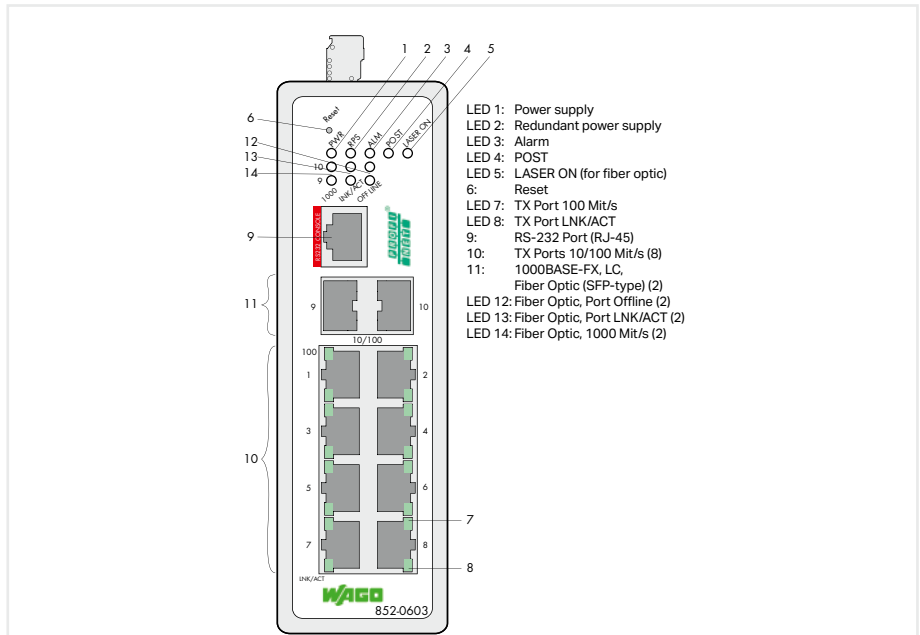

Item no.	852-603
Order Text	Managed-Switch; 8Port 100BASE-TX; 2Slot 1000BASE-SX/LX; PROFINET; T

Technical data	
Switching mode	Store-and-forward; non-blocking
Number of copper ports	8 x 100BASE-TX (RJ-45)
Number of FOC ports	2 x 1000BASE-SX/LX/ZX or 100BASE-FX (SFP slot)
Communication standards	IEEE 802.3 10BASE-T; IEEE 802.3u 100BASE-TX; IEEE 802.3z 1000BASE-SX/LX; IEEE 802.3x Flow Control; IEEE 802.1d Spanning Tree Protocol (STP); IEEE 802.1w Rapid Spanning Tree Protocol (RSTP); IEEE 802.1s Multiple Spanning Tree Protocol (MSTP); IEEE 802.1Q VLAN Tagging; IEEE 802.1p Class of Service; IEEE 802.1ab Link Layer Discovery Protocol (LLDP); PROFINET Conformance Class B
Redundancy function	Redundant DC power supply; STP; RSTP; MSTP; Media redundancy protocol as manager or client
Configuration options	DIP switch for signal contact; Web-Based Management; Command Line Interface; SNMPv1/v2c/v3
Diagnostics	Signal contact; Port status; Port statistics; Port load; Traffic monitor; SFP information; Syslog; SNMP traps; PN diagnostics (cyclic and acyclic)
MAC table (size)	16000 addresses
Jumbo frame size	10000 bytes
Supply voltage	12 ... 60 VDC
Power consumption (max.)	12 W
ESD (contact/air discharge)	8 KV / 15 KV
Connection technology: communication/fieldbus	Copper cable: 8 x RJ-45; Fiber optic: 2 x SFP-slots (e.g., with SFP module and LC fiber-optic connector)
Ambient temperature (operation)	-40 ... +70 °C
Dimensions W x H x D	(50 x 162 x 120) mm
Approvals	CE, OrdLoc
For data sheet and additional information, see:	wago.com/852-603

Accessories	Item no.
SFP Module 100BASE; FX Multi-Mode 1310 nm LC; 2 km; silver-colored	852-201/107-002
SFP Module 100BASE; LX Single-Mode 1310 nm LC; 30 km; silver-colored	852-201/107-030
SFP Module 1000BASE; ZX Single-Mode 1550 nm LC; 80 km; Extended temperature range; Digital Diagnostics Monitoring; silver-colored	852-1280
SFP Module 1000BASE; SX Multi-Mode 850 nm LC; 0.55 km; Extended temperature range; DDM; silver-colored	852-1200
SFP Module 1000BASE; LX Single-Mode 1310 nm LC; 10 km; Extended temperature range; Digital Diagnostics Monitoring; silver-colored	852-1210

10

PROFINET® Managed ▶ 8 ports 1000BASE-T; 4 slots 1000BASE-SX/LX; PROFINET



852-1605

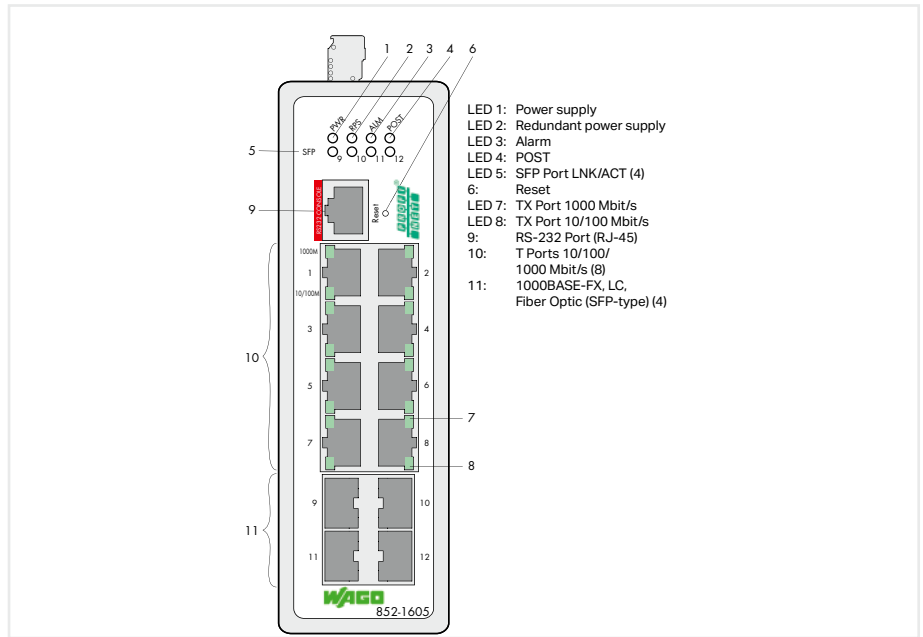

Item no.	852-1605
Order Text	Managed-Switch; 8Port 1000BASE-T; 4Slot 1000BASE-SX/LX; PROFINET; T
Technical data	
Switching mode	Store-and-forward; non-blocking
Number of copper ports	8 x 1000BASE-T or 100BASE-TX (RJ-45)
Number of FOC ports	4 x 1000BASE-SX/LX (SFP slot)
Communication standards	IEEE 802.3 10BASE-T; IEEE 802.3u 100BASE-TX; IEEE 802.3ab 1000BASE-T; IEEE 802.3z 1000BASE-SX/LX; IEEE 802.3x Flow Control; IEEE 802.1d Spanning Tree Protocol (STP); IEEE 802.1w Rapid Spanning Tree Protocol (RSTP); IEEE 802.1s Multiple Spanning Tree Protocol (MSTP); IEEE 802.1Q VLAN Tagging; IEEE 802.1p Class of Service; IEEE 802.1ab Link Layer Discovery Protocol (LLDP); PROFINET Conformance Class B
Redundancy function	Redundant DC power supply; STP; RSTP; MSTP; Media redundancy protocol as manager or client
Configuration options	DIP switch for signal contact; Web-Based Management; Command Line Interface; SNMPv1/v2c/v3
Diagnostics	Signal contact; Port status; Port statistics; Port load; Traffic monitor; SFP information; Syslog; SNMP traps; PN diagnostics (cyclic and acyclic)
MAC table (size)	16000 addresses
Jumbo frame size	10000 bytes
Supply voltage	12 ... 60 VDC
Power consumption (max.)	12 W
ESD (contact/air discharge)	8 KV / 15 KV
Connection technology: communication/fieldbus	Copper cable: 8 x RJ-45; Fiber optic: 4 x SFP-slots (e.g., with SFP module and LC fiber-optic connector)
Ambient temperature (operation)	-40 ... +70 °C
Dimensions W x H x D	(50 x 162 x 120) mm
Approvals	CE, OrdLoc
For data sheet and additional information, see:	wago.com/852-1605
Accessories	
SFP Module 1000BASE; ZX Single-Mode 1550 nm LC; 80 km; Extended temperature range; Digital Diagnostics Monitoring; silver-colored	852-1280
SFP Module 1000BASE; SX Multi-Mode 850 nm LC; 0.55 km; Extended temperature range; DDM; silver-colored	852-1200
SFP Module 1000BASE; LX Single-Mode 1310 nm LC; 10 km; Extended temperature range; Digital Diagnostics Monitoring; silver-colored	852-1210

Industrial Switches – Accessories

SFP Modules

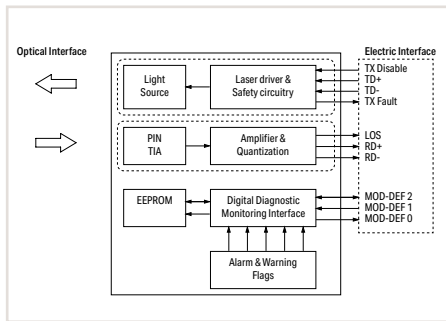

Features:

- Duplex LC optical connector
- Small Form-Factor Pluggable (SFP) industry-standard design
- Compliant with Fast ETHERNET and Gigabit ETHERNET (IEEE802.3z) standards
- Differential LVPECL inputs and outputs
- Supply voltage: 3.3 V
- TTL signal detect indicator
- Hot-pluggable capability

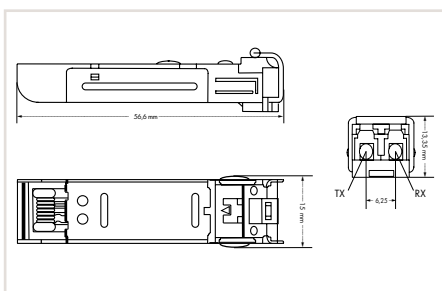

Item Description	SFP Module 1000BASE; SX Multi-Mode 850 nm LC; 0.55 km; Extended Temperature Range; DDM
Item No.	852-1200

SFP Module 1000BASE; LX Single-Mode 1310 nm LC; 10 km; Extended Temperature Range; DDM	SFP Module 1000BASE; ZX Single-Mode 1550 nm LC; 80 km; Extended Temperature Range; DDM
852-1210	852-1280

Technical Data	
Optical fiber type	Multi-mode
Cable length (max.)	300 m; 550 m
Cable type	62.5/125 μm, 50/125 μm
Wavelength	850 nm
Surrounding air temperature (operation)	-40 ... +85 °C

	Single-mode	
	10 km	80 km
	9/125 μm	
	1310 nm	1550 nm
	-40 ... +85 °C	

Item Description	SFP Module 2: 1310 nm; 100BASE-FX Multi-Mode LC; 2 km
Item No.	852-201/107-002

Technical Data	
Optical fiber type	Multi-mode
Cable length (max.)	2 km
Cable type	62.5/125 μm, 50/125 μm
Wavelength	1310 nm
Surrounding air temperature (operation)	-40 ... +70 °C

SFP Module 30: 1310 nm; 100BASE-FX Single-Mode LC; 30 km	SFP Module 30: 1310 nm; 100BASE-FX Single-Mode LC; 30 km
852-201/107-030	852-201/107-030

Features:

- Low Power
- Coated PCB
- Extended surrounding air temperature: -40 ... 100 °C
- High impulse withstand voltage: 1.2 kVDC
- Duplex LC optical connector
- Small Form-Factor Pluggable (SFP) industry-standard design
- 125Mbps 100BASE-LX10, IEEE 802.3 Clause 58
- Compliant with the Fast ETHERNET standard
- Digital Diagnostic Monitoring interface according to SFF-8472
- Supply voltage: 3.3 V
- TTL signal detect indicator
- Hot-pluggable capability

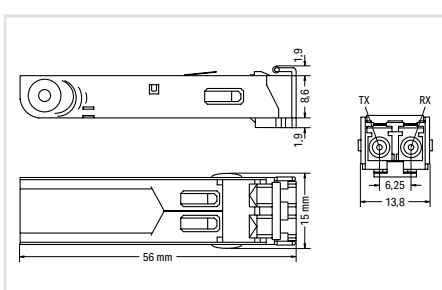

Item Description	SFP Module 100BASE; FX Multi-Mode 1310 nm LC; 2 km; DDM; Extended Temperature Range; DDM
Item No.	852-202

Technical Data	
Optical fiber type	Multi-mode
Cable length (max.)	2 km
Cable type	62.5/125 μm, 50/125 μm
Wavelength	1310 nm
Surrounding air temperature (operation)	-40 ... +100 °C

10

Industrial Switches – Accessories

SFP Modules

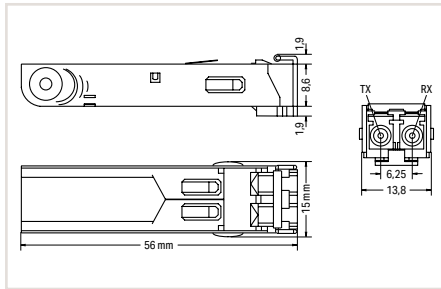

Features:

- Low Power
- Coated PCB
- Extended surrounding air temperature: -40 ... 95 °C
- High impulse withstand voltage: 0.7 kVDC
- Duplex LC optical connector
- Small Form-Factor Pluggable (SFP) industry-standard design
- 125Mbps 100BASE-LX10, IEEE 802.3 Clause 58
- Compliant with the Fast ETHERNET standard
- Digital Diagnostic Monitoring interface according to SFF-8472
- Supply voltage: 3.3 V
- TTL signal detect indicator
- Hot-pluggable capability
- Class 1 laser according to IEC 60825

Item Description	SFP Module 100BASE; LX Single-Mode 1310 nm LC; 30 km; DDM; Extended Temperature Range
Item No.	852-230
Technical Data	
Optical fiber type	Single-mode
Cable length (max.)	30 km
Cable type	9/125 µm
Wavelength	1310 nm
Surrounding air temperature (operation)	-40 ... +95 °C



Radio Technology

Radio Technology

- Bluetooth®
- WLAN
- EnOcean®

Radio Technology – Bluetooth®, WLAN and EnOcean® Components

Contents

			Page
		General Product Information	620
		Interfaces and Types	621
		Application and Installation Instructions	622
		Beschreibung	Bestellnr.
		Wireless ETHERNET Gateway	758-918
		Wireless ETHERNET Gateway; External Antenna	758-918/000-001
		Wireless Access Point	758-919
			625
		EnOcean® RS-485 Gateway; 868 MHz	750-940
			626
		Radio Transmitter, EnOcean® easyfit PTM 250	627
		2-Channel Lighting Control	758-940/001-000
		4-Channel Lighting Control	758-940/003-000
		2-Channel Sunblind Control	758-940/002-000
		4-Channel Sunblind Control	758-940/004-000
	Accessories		
	Antennas		628

Radio Technology

General Product Information

Wireless Technology in the Industrial Environment

Wireless technology can support wired applications or enable completely new applications.

In mobile or movable systems, wireless technology is the first choice when greater distances or obstacles must be overcome. It is an alternative for applications in which wired solutions are not economical or technically feasible.

Various wireless technologies can be used depending on the application.



Bluetooth® – Robust, Flexible, High-Performance

Well-known in consumer electronics, *Bluetooth®* technology is also well-suited to industrial use with its internationally approved frequency range, a very robust transmission technology (frequency hopping), real-time response and a range of up to 400 m. It makes wireless process data communication between two stations possible (point-to-point communication), and also enables the setup of a piconet in which a *Bluetooth®* master can communicate with up to seven slaves, e.g., decentralized mobile sensors.

In addition, *Bluetooth®* can be used as the radio system for commissioning.

Features:

- Secure transmission (encrypted)
- AFH (Adaptive Frequency Hopping)
- Adaptive transmission power
- Uses the license-free 2.4 GHz frequency band



WLAN – Full IT Integration

WLAN makes it easy to set up a wireless transmission link for ETHERNET protocols. This can be standard ETHERNET protocols, e.g., for communication between a smartphone and automation components. Industrial fieldbus protocols such as PROFINET, Modbus TCP or Ethernet/IP can also be used to link mobile equipment with stationary equipment. Ranges up to 400 m are possible depending on the transmission technology used.

EnOcean® – The Radio Standard in Building Automation



enocean®

Wireless switches and sensors based on EnOcean® technology harvest available energy to power themselves, e.g., kinetic energy from actuating a switch or sensors powered by ambient light. This energy harvesting completely eliminates maintenance of the radio transmitter at a range of up to 300 m in open air (30 m in buildings).

Advantages:

- Branch and application-specific – always the right radio system
- Industrial design – high-performance, rugged and safe
- Tightly integrated into WAGO automation technology

Radio Technology Interfaces and Types

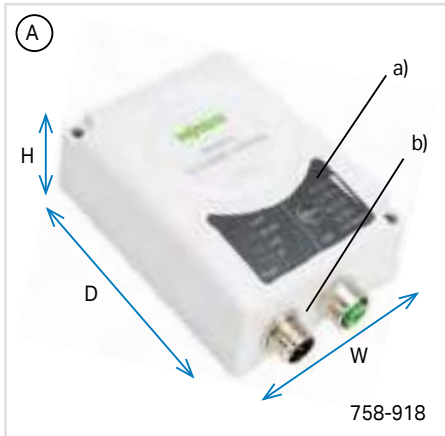

ETHERNET Gateway (A)

- Wireless transmission via WLAN (IEEE802.11a/b/g/d/n/r), *Bluetooth®* or *Bluetooth®* Low Energy
- Works as an access point, client or gateway
- Two internal 2.4 GHz and 5 GHz dual-band antennas and an integrated 2.4 GHz MIMO antenna
- Status and diagnostic LEDs (a)
- M12 connectors for both network connection and power supply (b)
- Protection type: IP65
- W x H x D (mm): 66 x 36.2 x 91

Wireless Access Point (B)

- Wireless transmission via WLAN (IEEE802.11a/b/g/d/n/r), *Bluetooth®* or *Bluetooth®* Low Energy
- Internal 2.4 GHz and 5 GHz dual-band antenna
- Protection type (top): IP66/IP67 (outside of unit)
- M50 through-panel installation (cut-out: 50.5 mm)



EnOcean® RS-485 Gateway (C);

Communication module for I/O system

- Integration of sensors/actuators based on EnOcean® wireless technology into intelligent control systems such as the WAGO I/O system
- Communication via RS-485 interface using ESP3 telegrams (EnOcean®) or Modbus® protocol
- Internal antenna (optional external antenna)
- Dimensions (mm) Diameter x Height 95 x 36

Switch Inserts (D)

- Universal switch inserts for standard switch series in building automation
- Compatible with manufacturer programs from BERKER, GIRA, JUNG, MERTEN



Radio Technology

Application and Installation Instructions

ETHERNET Bridge

- Transmission of each TCP/IP protocol along with prioritized PROFINET RT and EtherNet/IP™ frames
- Pairing via device's push-button (758-918 only)
- Up to 7 clients
- Use of Wi-Fi or Bluetooth®

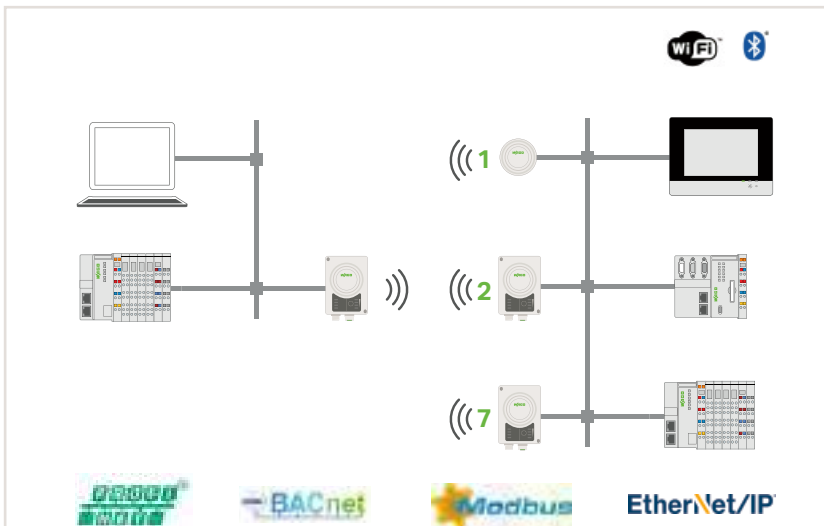

Client for Existing Access Point

- Connection to a Wi-Fi 802.11a/b/g/n/d/r network
- Protocols like Modbus TCP, EtherNet/IP™, BACnet/IP ...
- Possibility of connecting multiple devices after the client

Note X1: 758-918 or 758-919

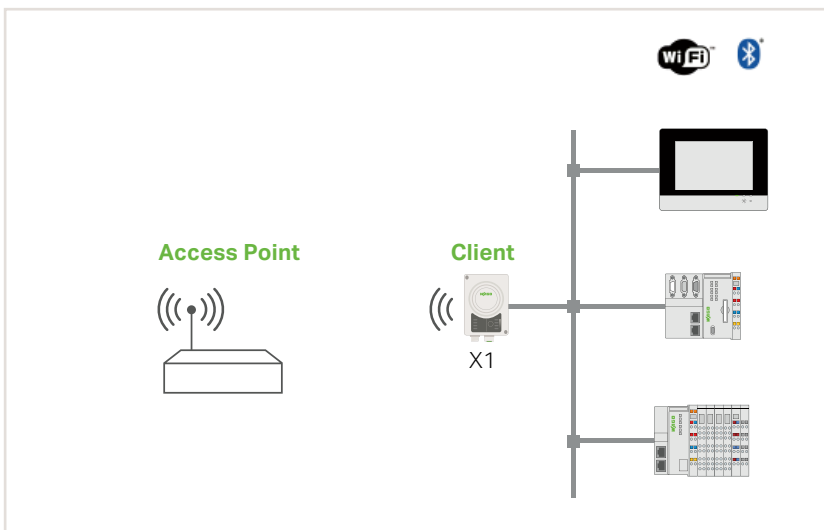

Access Point

- Setup of a Wi-Fi 802.11a/b/g/n/d/r or Bluetooth® network
- Connection of tablets, smartphones ...
- Up to 7 clients simultaneously

Note X1: 758-918 or 758-919

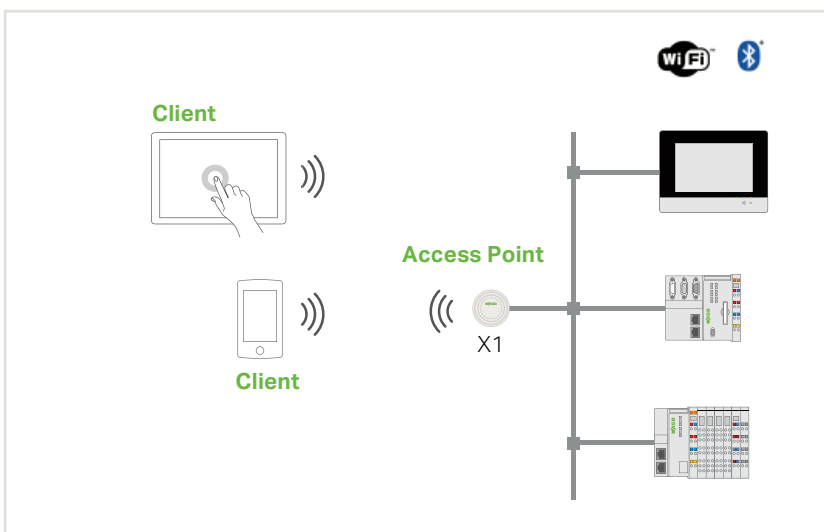

11

Radio Technology

Application and Installation Instructions

Integration into the WAGO I/O System via EnOcean® Radio Technology

- Communication via the EnOcean® RS-485 Gateway in the WAGO I/O System
- Operation on:
 - Controllers
 - Fieldbus couplers
- Internal antenna (optional external antenna)

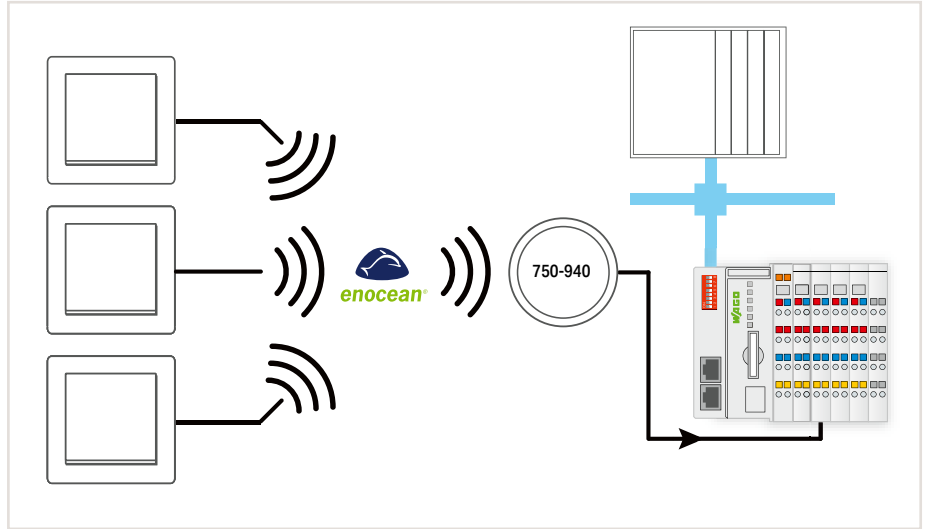

WLAN ETHERNET Gateway



Power connector:

M12 plug, A-coded



- 1: Vin + (9 ... 30 VDC)
- 2: Digital input GND
- 3: Vin GND (0 V)
- 4: Digital input + (9 ... 30 VDC)
- 5: Functional ground

ETHERNET connector:

M12 socket, D-coded



- 1: Transmit +
- 2: Receive +
- 3: Transmit -
- 4: Receive -

Item Description	Wireless ETHERNET Gateway	
Version	External Antenna	
Item No.	758-918	758-918/000-001
Order Text	Wireless ETHERNET Gateway	Wireless ETHERNET Gateway; External Antenna
Technical Data		
Wireless technology	Bluetooth®: 4.0; WLAN: 802.11a/b/g/d/e/i/h	
Topology	Peer-to-peer connection	
Security authentication	WLAN: WPA/WPA2 PSK; LEAP; PEAP	
Security encryption	WLAN: none; WEP64; WEP128; TKIP; AES/CCMP	
Frequency band	ISM band; 2.4 GHz (Bluetooth®, WLAN); ISM band; 5 GHz (WLAN)	
Transmission range	Up to 400 m*	
Antenna	Internal directional antenna	External dipole antenna (3dBi); included in delivery
Supply voltage	24 VDC (9 ... 30 V)	
Connectors	ETHERNET connection: M12 connector, D-coded Power connection: M12 connector, A-coded; RP-SMA socket for external antenna	
Configuration	Simple push-button operation and Web-Based Management	
Number of inputs	1 (trigger input: 9 ... 30 VDC)	
Surrounding air temperature (operation)	-30 ... +65 °C	
Dimensions W x H x D	67.8 x 33.2 x 92.7	
Protection type	IP65	
Approvals	CE	
For data sheet and additional information, see:	wago.com/758-918	
Accessories		
ETHERNET/PROFINET Cable; M12 plug; straight; D-coded; 2 m	756-1201/060-020	
Power Cable; M12 socket; straight; A coded; 2 m	756-3102/040-020	
PROFINET RJ-45 Plug; IP20	750-976	

WAGO's Wireless ETHERNET Gateway simplifies the creation of a wireless transmission link for ETHERNET protocols (e.g., PROFINET, Modbus/TCP, EtherNet/IP™). The gateway works as a cable substitute to create a robust, industry-proven Bluetooth® or WLAN link between two automation devices.

This gateway supports various configurations and can therefore also be operated as an access point. IP65 protection type and an external antenna allow installation of the Wireless ETHERNET Gateway within a conductive housing. The external antenna must be mounted on the outside of the housing. Simple push-button operation rapidly connects two Wireless ETHERNET Gateways.

Additional settings can be made via Web-Based Management.

Note:

Two Wireless ETHERNET Gateways of the same type are required to establish a peer-to-peer connection.

*The maximum range in the field decreases within buildings and varies depending on building materials and spatial geometry. Therefore, range specifications within buildings can only represent a typical value that can normally be achieved. More detailed information is available in the manual.

Wireless Access Point

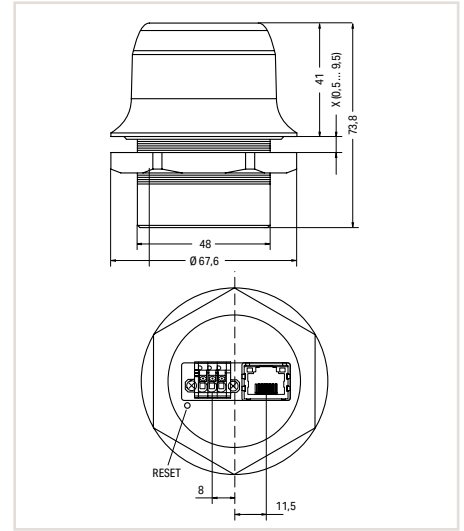

Item Description	Wireless Access Point
Item No.	758-919
Order Text	Wireless Access Point
Technical Data	
Wireless technology	Bluetooth® 2.1; Bluetooth® 4.0 (Low Energy); WLAN: IEEE 802.11 a, b, g, n, d, r
Frequency band	ISM band, 2.4 GHz (Bluetooth®, WLAN); ISM band, 5 GHz (WLAN)
ETHERNET protocols	IP; TCP; UDP; HTTP; LLDP; ARP; DHCP client/server; DNS support; transparent transmission of PROFINET IO; EtherNet/IP™; Modbus-TCP or another TCP/UDP-based protocol
Antenna	Internal 2.4 GHz and 5 GHz broadband antenna
Transmission range	Up to 200 m in open air*
Supply voltage	19 ... 36 VDC
Power consumption (max.)	1.7 W
Configuration	Web-Based Management
Maximum number of clients	7
WLAN	
Transmitter power	15 dBm EIRP
Operating modes	Wireless access point, wireless client or gateway mode
Communication standards	IEEE 802.11 a, b, g, n, d, r
Data rate (net) (max.)	65 Mbit/s
Security	WEP 64/128; WPA; WPA-PSK and WPA2; TKIP and AES/CCMP; LEAP; PEAP including MS-CHAP
Bluetooth® 2.1	
Transmitter power	11 dBm EIRP
Supported profiles	PAN (PANU & NAP)
Operating modes	Access point, client or gateway mode
Data rate (net)	1 Mbit/s
Security	NIST-compliant; FIPS-approved (authentication and authorization, encryption and data security, privacy and discretion)
Bluetooth® 4.0 (Low Energy)	
Transmitter power	7 dBm EIRP
Supported profiles	GATT
Operating modes	Central device
Data rate (net)	200 Kbit/s
Security	AES-CCM encryption
Connector	RJ-45; 10/100BASE-T (Auto MDI/MDIX & cross-over detection); PoE supply: 44 ... 57 VDC; DTE type 1 per IEEE 802.3af
Dimensions	Height: 75 mm (91 mm with connector); Outside height: 41 mm; Diameter: 68 mm
Weight	84 g
Surrounding air temperature (operation)	-40 ... +65 °C
Protection type	Top (outside of unit): IP66/IP67/UL NEMA 4X ; Base (inside of unit): IP21
Mounting	M50 through-panel installation (cut-out = 50.5 mm)
Approvals	CÉ; UL 61010 E198726; FCC; IC: 5325A-0965, for indoor use only (5 GHz)
For data sheet and additional information, see:	wago.com/758-919

*The maximum range in the field decreases within buildings and varies depending on building materials and spatial geometry. Therefore, range specifications within buildings can only represent a typical value that can normally be achieved. More detailed information is available in the manual.

EnOcean® RS-485 Gateway; 868 MHz

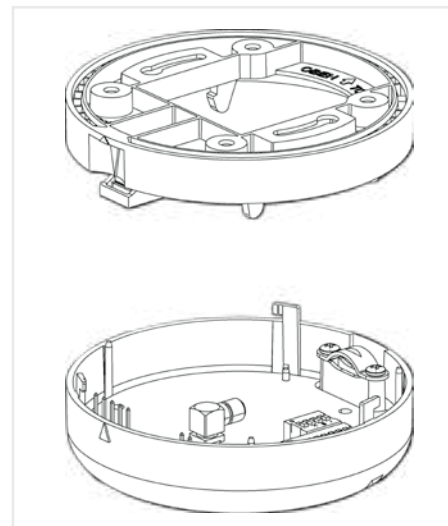
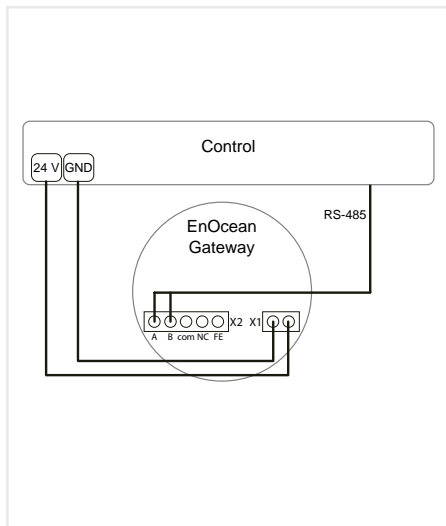

Item Description

Item No.

Technical Data

Wireless technology

Frequency band

Transmission range

Antenna

Interface

Protocol

Transmission rate

Data width

Cable length

Power supply

Input current

Connection technology

EnOcean® RS-485 Gateway; 868 MHz

750-940

EnOcean®

868 MHz

Approx. 30 m within buildings;
>100 m in open space

Internal (external antenna optional via SMA socket)

RS-485

ESP3, Modbus®

9600 ... 115200 Baud

50 bytes

100 m (max.)

24 VDC (-25 ... +30 %)

2 A (max.)

RS-485 connection:

5-pole 2-conductor compact PCB connectors
with PUSH WIRE® (252-155 is included)

Supply connection: 2-pole 2-conductor compact
PCB connectors with PUSH WIRE® (252-152 is
included)

Antenna: SMA socket for external antenna

Solid: 0.4 ... 0.8 mm² / 26 ... 20 AWG

6 ... 7 mm

95 × 36

103 g

IP30 (front side)

0 ... +55 °C

-20 ... +85 °C

EN 61000-6-2

EN 61000-6-3 + A1

CE

Data sheet and additional information, see:

wago.com/750-940

The EnOcean® RS-485 Gateway integrates maintenance-free, battery-free and wireless sensors/actuators based on EnOcean® wireless technology (ISO/IEC 14543-3-1x) into intelligent control systems such as the WAGO I/O System.

This gateway communicates with the remote station via RS-485 interface and ESP3 telegrams (EnOcean®) or via Modbus® protocol.

It may be mounted directly to the ceiling or wall. The device can also be mounted on a DIN-rail via an integrated adapter.

The gateway has an internal antenna and also has a connector for an optional external antenna.

Radio Transmitter, EnOcean® easyfit PTM 250

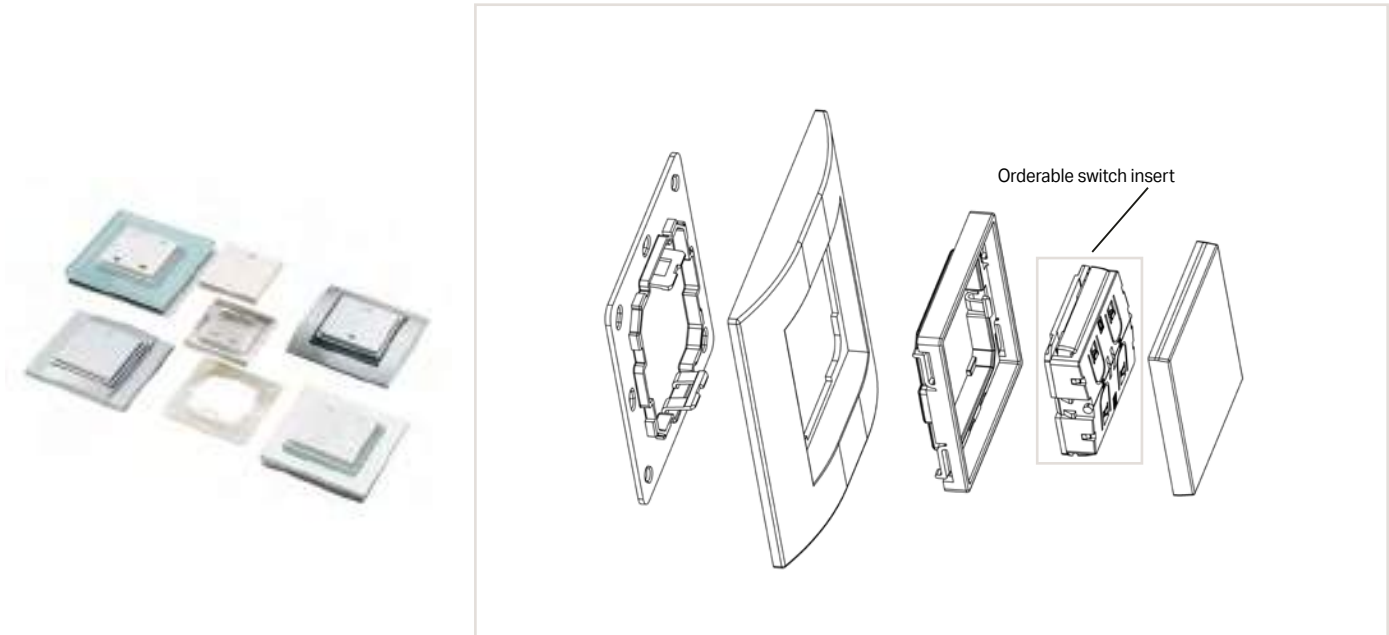

Item Description	Radio Transmitter, EnOcean® easyfit PTM 250			
Version	2-Channel Lighting Control	4-Channel Lighting Control	2-Channel Sunblind Control	4-Channel Sunblind Control
Item No.	758-940/001-000	758-940/003-000	758-940/002-000	758-940/004-000
Order Text	Radio Transmitter; EnOcean® easyfit PTM 250; 2-Channel Light	Radio Transmitter; EnOcean® easyfit PTM 250; 4-Channel Light	Radio Transmitter; EnOcean® easyfit PTM 250; 2-Channel Sunblind	Radio Transmitter; EnOcean® easyfit PTM 250; 4-Channel Sunblind

Technical Data					
Integrated radio transmitter module	EnOcean® PTM 200				
Wireless technology	EnOcean® 868 MHz; RPS type 2				
Range	300 m in open air; 30 m (typ.) within buildings*				
Antenna	Integrated				
Total installation height	14 mm (frame lies directly on flat surface)				
Dimensions of rocker/frame cut-out/center plate	50 x 50 mm / 55 x 55 mm / 71 x 71 mm				
Mounting	Flat surface; glued (double-sided mounting film enclosed) or screwed				
Color	Pure white				
Rocker switch variant	<table border="1"> <tr> <td>Rocker switch with neutral middle position</td> <td>Series rocker switch</td> <td>Rocker switch with neutral middle position</td> <td>Series rocker switch</td> </tr> </table>	Rocker switch with neutral middle position	Series rocker switch	Rocker switch with neutral middle position	Series rocker switch
Rocker switch with neutral middle position	Series rocker switch	Rocker switch with neutral middle position	Series rocker switch		
Relative humidity	95 % (non condensing)				
Surrounding air temperature (operation)	-25 ... +65 °C				
Compatibility	BERKER, GIRA, JUNG, MERTEN				
Approvals	R&TTE, CE				
For data sheet and additional information, see:	wago.com/758-940				

WAGO's EnOcean® easyfit PTM 250 Radio Transmitter is a universal, extremely flat wireless switch insert with a maintenance-free energy generator. This universal switch insert fits in numerous frame types from various installation material suppliers. The base plate can be glued or screwed into position for easy attachment to glass as well as plaster. Integration into the frame is similar to universal inserts for antenna sockets.

The switch insert is delivered without frame. Frames must be ordered separately from the desired manufacturer!

*The maximum range in the field decreases with use in buildings and changes depending on the building materials used and the spatial geometry. Therefore, range specifications within buildings can only represent a typical value that can normally be achieved. More detailed information is available in the manual.

Magnetic-Mount Antenna; with 3 m cable and SMA plug; GSM/ UMTS; 850/ 900/ 1800/ 1900/ 2100 MHz

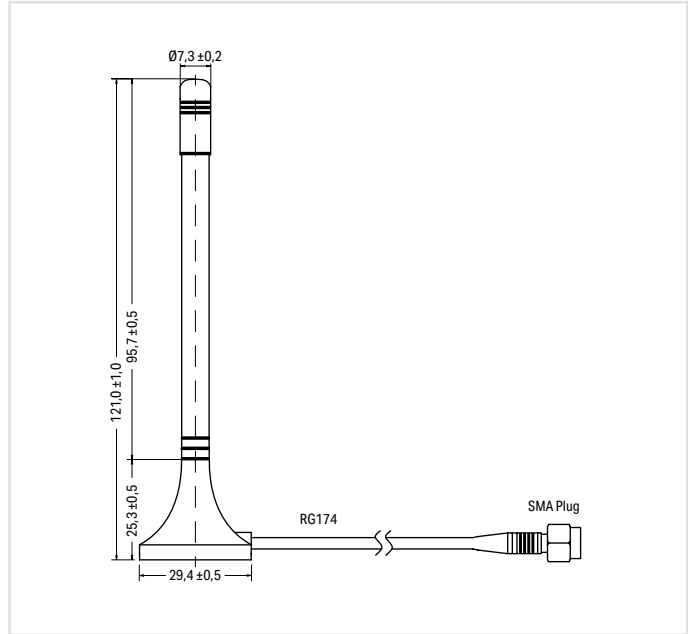

Item Description

Item No.

**Magnetic-Mount Antenna; with 3 m cable and SMA plug;
GSM/ UMTS; 850/ 900/ 1800/ 1900/ 2100 MHz**

758-911

Technical Data	
Wireless technology	GSM; UMTS; EnOcean
Frequency band	824 ... 960 MHz; 1710 ... 2170 MHz
Gain	2 dBi
Mechanical Data	
Connector	SMA-Stecker
Connection cable length	3 m
Mounting type	Magnetic stand
Cable type	RG-174
Weight	44 g
Surrounding air temperature (operation)	-40 ... +85 °C

GSM; UMTS; EnOcean
824 ... 960 MHz; 1710 ... 2170 MHz
2 dBi
SMA-Stecker
3 m
Magnetic stand
RG-174
44 g
-40 ... +85 °C

Magnetic-Mount Antenna; GSM/UMTS/LTE/*Bluetooth*[®]/WLAN

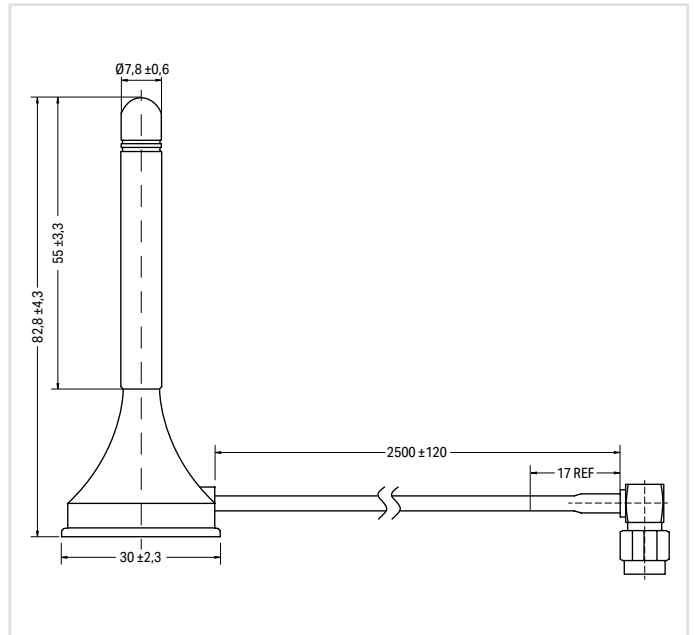

Item Description

Item No.

Technical Data

Wireless technology

Frequency band

Gain

Mechanical Data

Connector

Connection cable length

Mounting type

Cable type

Weight

Surrounding air temperature (operation)

Magnetic-Mount Antenna; with 2.5 m cable and SMA angled plug;
GSM/UMTS/LTE/*Bluetooth*[®]/WLAN; 698-960, 1400-1518, 1710-2700 MHz

758-975

GSM; UMTS; LTE; *Bluetooth*[®]; WLAN

B1 ... B23; B25 ... B30; B32 ... B42; B48; B66; B74 ... 76; B78

Frequency range: 698 ... 960 MHz; 1400 ... 1518 MHz; 1710 ... 2700 MHz

3 dBi

SMA angled plug

2.5 m

Magnetic stand

RG-174

44 g

-40 ... +85 °C

RF Antenna; GSM; UMTS; LTE; *Bluetooth*[®]; WLAN; 5G



758-974

758-974/000-001

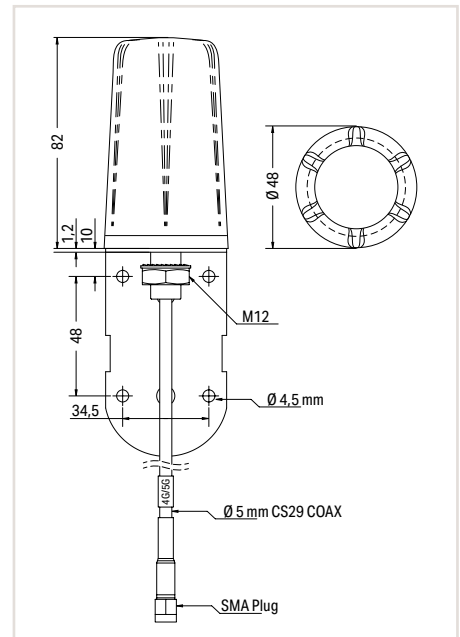
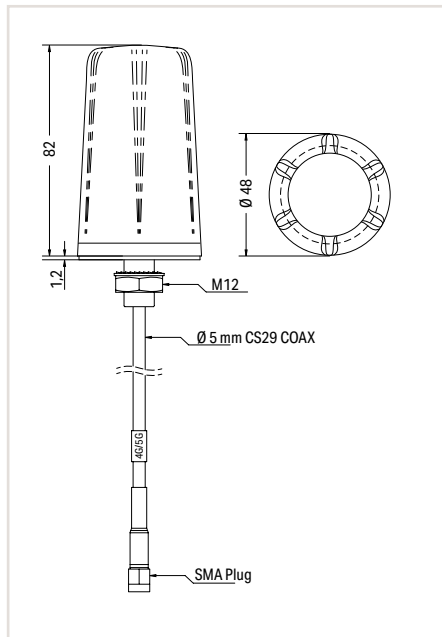

Item Description	RF Antenna; with 2.5 m cable and SMA plug; GSM/UMTS/LTE/ <i>Bluetooth</i> [®] /WLAN; 698-960, 1710-6000 MHz; 2G/ 3G/ 4G/ 5G	RF Antenna; with 2.5 m cable and SMA plug; GSM/UMTS/LTE/ <i>Bluetooth</i> [®] /WLAN; 698-960, 1710-6000 MHz; 2G/ 3G/ 4G/ 5G
Item No.	758-974	758-974/000-001

Technical Data		
Wireless technology	GSM; UMTS; LTE; <i>Bluetooth</i> [®] ; WLAN; 5G	GSM; UMTS; LTE; <i>Bluetooth</i> [®] ; WLAN; 5G
Frequency band	617 ... 960 MHz; 1710 ... 6000 MHz	617 ... 960 MHz; 1710 ... 6000 MHz
Gain	617 ... 960 MHz: 1dBi; 1710 ... 2700 MHz: 4dBi; 3400 ... 3800 MHz: 8dBi; 4900 ... 6000 MHz: 9dBi	617 ... 960 MHz: 1dBi; 1710 ... 2700 MHz: 4dBi; 3400 ... 3800 MHz: 8dBi; 4900 ... 6000 MHz: 9dBi
Mechanical Data		
Connectors	SMA plug	SMA plug
Connection cable length	2 m	2 m
Mounting type	Enclosure installation; adhesive strips	Wall-mount
Cable type	CS29	CS29
Weight	185 g	252 g
Protection type	IP66	IP66

- The antenna must be mounted on a conductive base plate measuring at least 40 x 40 cm.
 - The distance of interfering sources to the antenna and antenna line must be at least 30 cm.
 - The free space between the antenna and the next wall must be at least 35 cm.
 - The antenna cable must not, under any circumstances, be bent sharply, or the antenna line may be irreversibly damaged.
- The distance of interfering sources to the antenna and antenna line must be at least 30 cm.
 - The free space between the antenna and the next wall must be at least 35 cm.
 - The antenna cable must not, under any circumstances, be bent sharply, or the antenna line may be irreversibly damaged.



Sensor/Actuator Boxes

Sensor/Actuator Boxes

- M8 and M12 Sensor/Actuator Boxes
- Passive signal acquisition and output at the machine level
- Fully encapsulated

Sensor/Actuator Boxes

Contents

			Seite	
	General Product Information		634	
	Item Number Key		635	
	Standards and Rated Conditions		635	
	Approvals		635	
	Interfaces and Types		636	
		Description	Item No.	
	M12 Sensor/Actuator Boxes with Cable Connection	M12 Sensor/Actuator Box; 4-Port, 4-Pole; 5 m Connection Cable	757-244/000-005	638
		M12 Sensor/Actuator Box; 4-Port, 4-Pole; 10 m Connection Cable	757-244/000-010	
		M12 Sensor/Actuator Box; 6-Port, 4-Pole; 5 m Connection Cable	757-264/000-005	638
		M12 Sensor/Actuator Box; 6-Port, 4-Pole; 10 m Connection Cable	757-264/000-010	
		M12 Sensor/Actuator Box; 8-Port, 4-Pole; 5 m Connection Cable	757-284/000-005	639
		M12 Sensor/Actuator Box; 8-Port, 4-Pole; 10 m Connection Cable	757-284/000-010	
		M12 Sensor/Actuator Box; 8-Port, 4-Pole; 25 m Connection Cable	757-284/000-025	
		M12 Sensor/Actuator Box; 4-Port, 5-Pole; 5 m Connection Cable	757-245/000-005	640
		M12 Sensor/Actuator Box; 4-Port, 5-Pole; 10 m Connection Cable	757-245/000-010	
		M12 Sensor/Actuator Box; 6-Port, 5-Pole; 5 m Connection Cable	757-265/000-005	640
		M12 Sensor/Actuator Box; 6-Port, 5-Pole; 10 m Connection Cable	757-265/000-010	
		M12 Sensor/Actuator Box; 8-Port, 5-Pole; 5 m Connection Cable	757-285/000-005	641
		M12 Sensor/Actuator Box; 8-Port, 5-Pole; 10 m Connection Cable	757-285/000-010	
		M12 Sensor/Actuator Box; 8-Port, 5-Pole; 25 m Connection Cable	757-285/000-025	
	M12 Sensor/Actuator Boxes with M23 Connection	M12 Sensor/Actuator Box; 4-Port; 4-Pole; M23 Connector	757-144	642
		M12 Sensor/Actuator Box; 6-Port; 4-Pole; M23 Connector	757-164	642
		M12 Sensor/Actuator Box; 8-Port; 4-Pole; M23 Connector	757-184	643
		M12 Sensor/Actuator Box; 4-Port; 5-Pole; M23 Connector	757-145	644
		M12 Sensor/Actuator Box; 6-Port; 5-Pole; M23 Connector	757-165	644
		M12 Sensor/Actuator Box; 8-Port; 5-Pole; M23 Connector	757-185	645
		M12 Sensor/Actuator Box; 8-Port; 5-Pole; M23 Connector; without LED	757-185/100-000	
	M8 Sensor/Actuator Boxes with Cable Connection	M8 Sensor/Actuator Box; 4-Port, 3-Pole; 5 m Connection Cable	757-443/000-005	646
		M8 Sensor/Actuator Box; 4-Port, 3-Pole; 10 m Connection Cable	757-443/000-010	
		M8 Sensor/Actuator Box; 6-Port, 3-Pole; 5 m Connection Cable	757-463/000-005	646
		M8 Sensor/Actuator Box; 6-Port, 3-Pole; 10 m Connection Cable	757-463/000-010	
		M8 Sensor/Actuator Box; 8-Port, 3-Pole; 5 m Connection Cable	757-483/000-005	647
		M8 Sensor/Actuator Box; 8-Port, 3-Pole; 10 m Connection Cable	757-483/000-010	
		M8 Sensor/Actuator Box; 10-Port, 3-Pole; 5 m Connection Cable	757-403/000-005	647
		M8 Sensor/Actuator Box; 10-Port, 3-Pole; 10 m Connection Cable	757-403/000-010	
	M8 Sensor/Actuator Boxes with M16 Connection	M8 Sensor/Actuator Box; 4-Port; 3-Pole; M16 Connector	757-343	648
		M8 Sensor/Actuator Box; 6-Port; 3-Pole; M16 Connector	757-363	648
		M8 Sensor/Actuator Box; 8-Port; 3-Pole; M16 Connector	757-383	649
		M8 Sensor/Actuator Box; 10-Port; 3-Pole; M16 Connector	757-303	649
	Accessories	Marker Cards, Marking Strips, Protective Caps, Spacer Modules, Interconnection Cables		650

Sensor/Actuator Boxes

General Product Information

For Signal Acquisition at the Machine Level

WAGO's passive M8/M12 Sensor/Actuator Boxes are placed close to the process and acquire signals at the machine level. They can be used under very harsh environmental conditions and establish the connection between sensors/actuators and the controller via molded or detachable cables. Use of standardized pluggable connections supports plug-and-play installation of sensors and actuators, while trunk cables replace the individual wiring of I/O signals to automation components in the control cabinet. Cabling is well-organized and minimized.

Signal Acquisition in Exceptionally Harsh Conditions

WAGO's Sensor/Actuator Boxes with molded cables have an extremely robust design and meet both IP67 and IP68 protection standards (72 hours at 1 m water depth). This design makes them ideal for applications where signals must be recorded in extreme environments (temperature, shock, vibration) without a control cabinet. They're also excellent alternatives when using an active IP67 I/O system would not be cost-effective due to a low signal count or the simple signal conditions (only digital signal acquisition/output).

Plug-&-Play Connection Technology

The IP67 Sensor/Actuator Boxes with a removable connection cable (M16 or M23 pluggable connector) are ideal for areas where frequent easy disconnection and reconnection are required (e.g., transport, modification, service).

Fixed Trunk Cable

The IP68 Sensor/Actuator Boxes with molded cables are preferred when challenging cable paths do not allow the installation of M16/M23 cable assemblies.

Extreme Mechanical Performance

A system/machine is exposed to severe mechanical and thermal influences. It is important to process its signals despite severe vibrations and shocks. WAGO's Sensor/Actuator Boxes are used at the machine level. Full encapsulation safeguards system operation, so even extreme vibration and temperature loads do not degrade signal acquisition and power supply via the connection cable to the controller or other automation components located in the non-critical control cabinet area.

Flexible Installation

WAGO's Sensor/Actuator Boxes can be directly mounted on machines. Extensive engineering ensures compliance with standardized specifications from CNOMO guidelines regarding the spacing of assembly drill holes that are often used in passive distribution boxes or sensor/actuator boxes. An optional adapter is available for seamlessly mounting two modules side by side. This has the advantage of maintaining a specified distance for properly routing the sensor/actuator cables and avoiding contamination points.

Advantages:

- Rugged, simple and compact extension for IP20 automation components
 - for stricter requirements on environmental conditions
 - for plug-and-play connector technology when needed
 - for simpler cable installation in the form of trunk cables
- High-quality PUR connection cables (drag chain compatible, halogen-free)
- Fully encapsulated (resistance and leak-proof)
- Flange sockets (metal design)
- Surrounding air temperature (operation): -25 ... +80 °C
- Status LEDs

Sensor/Actuator Boxes

Item Number Key

Explanation of an item number key's components:

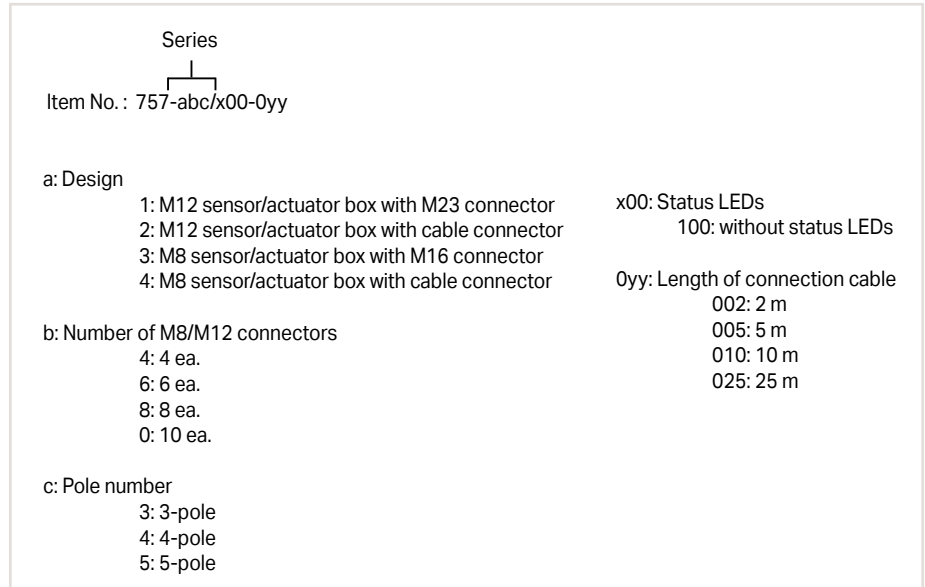

Standards and Rated Conditions

General Specifications	
Electrical Data	
Contact resistance (max.)	10 mΩ
Supply voltage	10 ... 30 VDC
Current carrying capacity (signal connections)	2 A
Current carrying capacity (supply connections)	9 A (M12) or 6 A (M8)
Signal characteristics	PNP
Mechanical Data	
Protection type	
Sensor/actuator boxes with cable connection	IP68 (72 hours at 1 m water depth)
Sensor/actuator boxes with M16/M23 connection	IP67
Surrounding air temperature (operation)	-25 ... +80 °C
Mounting	Screw mount
Mounting position	Any
Vibration resistance	5g per IEC 60068-2-6
Shock resistance	49g per IEC 60068-2-27
Material Data	
Housing material	PA 66 (UL 94 V0); RAL 7035; silicon and halogen free
Encapsulation	Fully encapsulated with conformal coating (UL 94 V0)
Connection cable	Drag chain compatible

Approvals

Overview of the approvals in the item comparison in Section 14, Technical Section, or online at www.wago.com



Sensor/Actuator Boxes Interfaces and Types

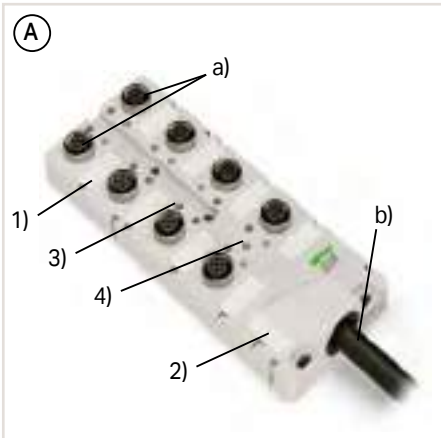

- (1) Sensor/actuator marking
(2) Module marking
(3) Yellow status LED (for each channel)
(4) Green operating status LED (module)

Housing Design (A)

- M12 sensor/actuator box with cable connection
- Sensor/actuator M12 sockets (a)
- Connection technology (trunk cable): fixed connection cable (b)

Housing Design (B)

- M8 sensor/actuator box with cable connection
- Sensor/actuator M8 sockets (a)
- Connection technology (trunk cable): fixed connection cable (b)

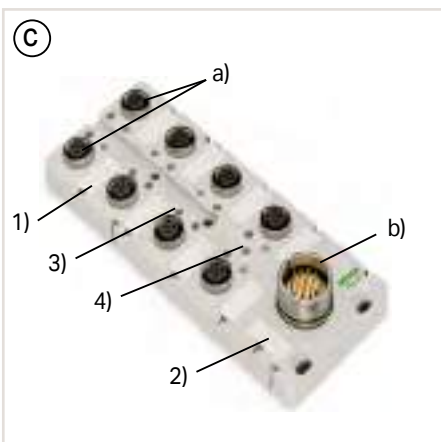
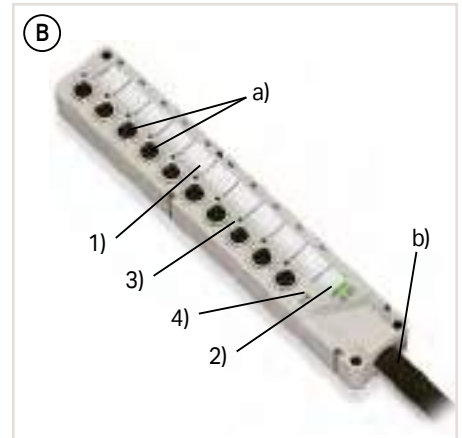

Housing Design (C)

- M12 sensor/actuator box with M23 plug
- Sensor/actuator M12 sockets (a)
- Connection technology (trunk cable): M23 plug (b)

Housing Design (D)

- M8 sensor/actuator box with M16 plug
- Sensor/actuator M8 sockets (a)
- Connection technology (trunk cable): M16 plug (b)

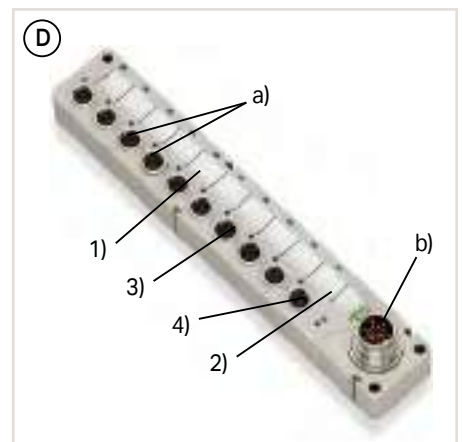

Spacer Module (E)

- Optional accessory
- For seamless assembly of two side-by-side sensor/actuator boxes
- Specified distance for proper cable connection
- Covers contamination points
- W x H x D (mm):
10-port: 20 x 16 x 175
8-port: 20 x 16 x 152
6-port: 20 x 16 x 123
4-port: 20 x 16 x 117

Protection Type (F)

- Fully encapsulated modules
- IP67/68 protection type
- Back-side printing details
pin assignment



Sensor/Actuator Boxes Interfaces and Types

Dimensions and Mounting Dimensions of M12 Sensor/Actuator Boxes
The dimensions also apply to M12 sensor/actuator boxes with cable connection.

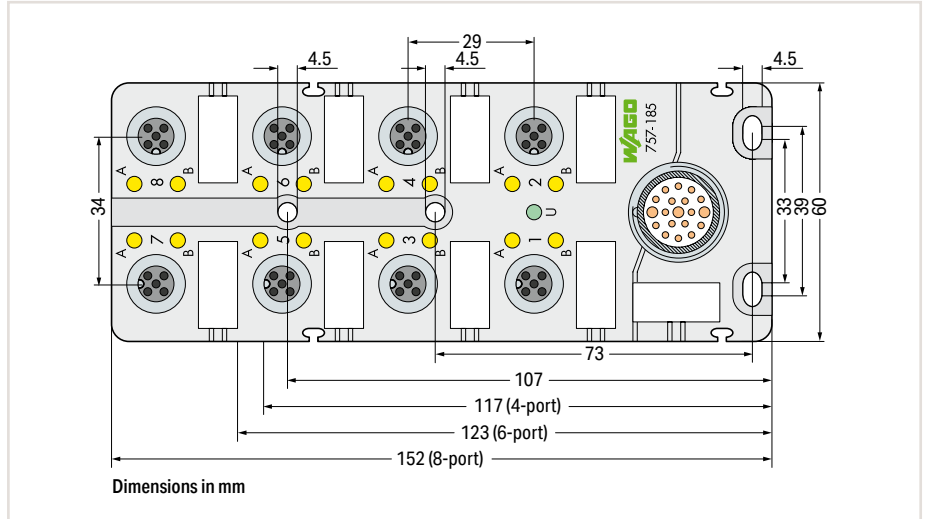

Dimensions and Mounting Dimensions of M8 Sensor/Actuator Boxes
The dimensions also apply to M8 sensor/actuator boxes with cable connection.

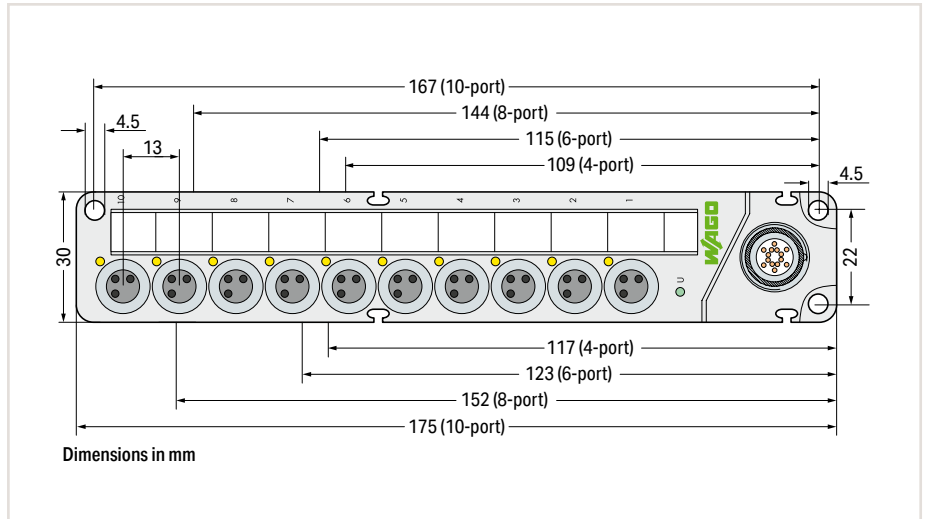

Dimensions:
Depth of M12 sensor/actuator boxes
or M8 sensor/actuator boxes

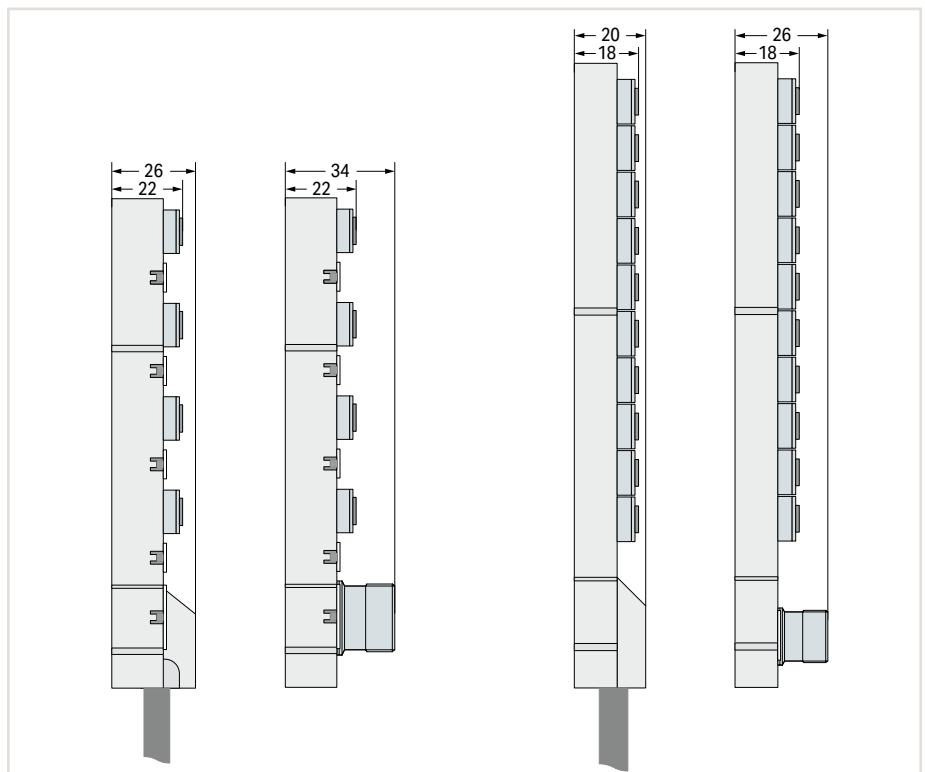

Sensor/actuator boxes ▶ M12 socket; 4-pole; incl. ground

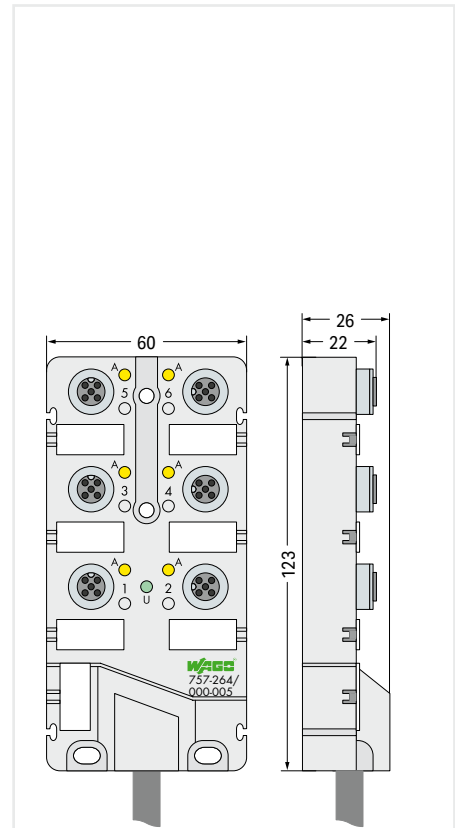
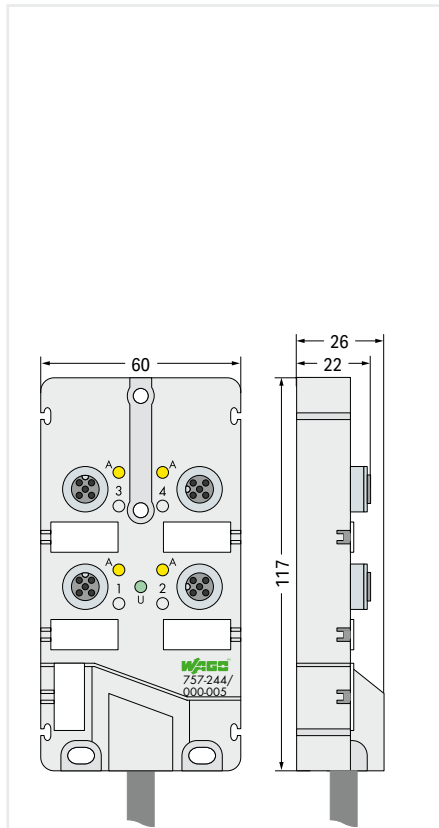

Connection technology: inputs/outputs
Item description
Version
Item no.
Order Text

4 x M12 socket; 4-pole; incl. ground	
M12 Sensor/Actuator Box; 4-port; 4-pole	
5 m connecting cable	10 m connecting cable
757-244/000-005	757-244/000-010
M12 S/A-Box; 4port; 4pole; 5m	M12 S/A-Box; 4port; 4pole; 10m

6 x M12 socket; 4-pole; incl. ground	
M12 Sensor/Actuator Box; 6-port, 4-pole	
5 m connecting cable	10 m connecting cable
757-264/000-005	757-264/000-010
M12 S/A-Box; 6port; 4pole; 5m	M12 S/A-Box; 6port; 4pole; 10m

Technical data	
Connection technology: inputs/outputs	4 x M12 socket; 4-pole; incl. ground
Pole number	4
Connection technology: trunk cable	1 x Fixed connecting cable
Length of connection cable	5 m 10 m
Dimensions W x H x D	(60 x 26 x 117) mm
Approvals	E 175199; Ⓢ OrdLoc; Class 2 Equipment; These components are designed to be supplied through Class 2 power supplies per UL 1310 or Class 2 transformers per UL 1585.

Technical data	
4 x M12 socket; 4-pole; incl. ground	
4	
1 x Fixed connecting cable	
5 m 10 m	
(60 x 26 x 117) mm	
E 175199; Ⓢ OrdLoc; Class 2 Equipment; These components are designed to be supplied through Class 2 power supplies per UL 1310 or Class 2 transformers per UL 1585.	

Technical data	
6 x M12 socket; 4-pole; incl. ground	
4	
1 x Fixed connecting cable	
5 m 10 m	
(60 x 26 x 123) mm	
E 175199; Ⓢ OrdLoc; Class 2 Equipment; These components are designed to be supplied through Class 2 power supplies per UL 1310 or Class 2 transformers per UL 1585.	

For data sheet and additional information, see:	
Accessories	
Fiber-tip pen	210-110
M12 protective cap; for unused sockets	756-8102
Marker card; not stretchable; snap-on type	757-011
Spacer module for sensor/actuator box; 4-way	757-040
Spacer module for sensor/actuator box; 6-way	-
Spacer module for sensor/actuator box; 8-way	-

wago.com/757-244/000-005	
Item no.	Item no.
210-110	210-110
756-8102	756-8102
757-011	757-011
757-040	757-040
-	-
-	-

wago.com/757-264/000-005	
Item no.	Item no.
210-110	210-110
756-8102	756-8102
757-011	757-011
-	-
757-060	757-060
-	-

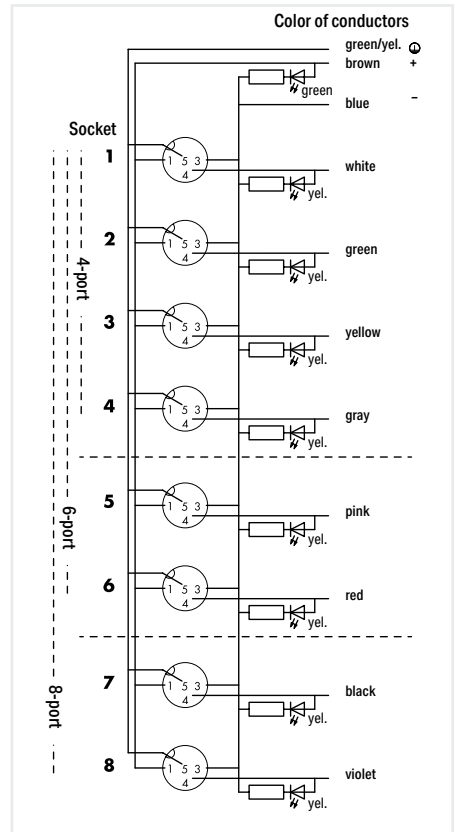
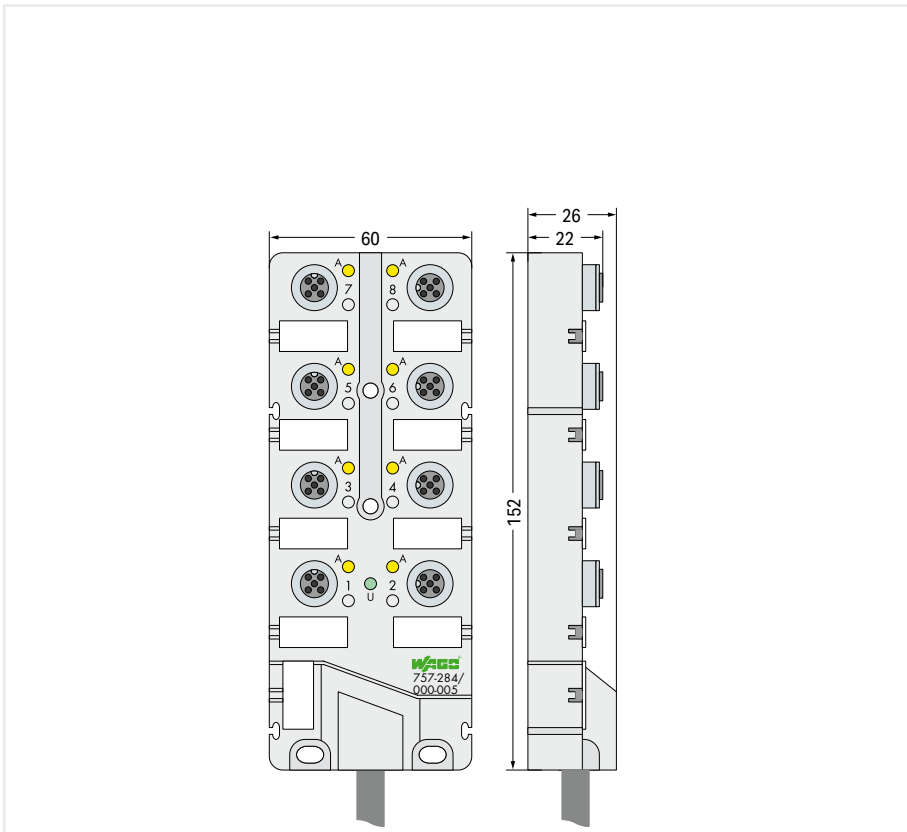

8 x M12 socket; 4-pole; incl. ground		
M12 Sensor/Actuator Box; 8-port, 4-pole		
5 m connecting cable	10 m connecting cable	25 m connecting cable
757-284/000-005	757-284/000-010	757-284/000-025
M12 S/A-Box; 8port; 4pole; 5m	M12 S/A-Box; 8port; 4pole; 10m	M12 S/A-Box; 8port; 4pole; 25m

8 x M12 socket; 4-pole; incl. ground		
4		
1 x Fixed connecting cable		
5 m	10 m	25 m
(60 x 26 x 152) mm		

E 175199; Ⓢ OrdLoc; Class 2 Equipment; These components are designed to be supplied through Class 2 power supplies per UL 1310 or Class 2 transformers per UL 1585.

wago.com/757-284/000-005			
Item no.	Item no.	Item no.	Item no.
210-110	210-110	210-110	210-110
756-8102	756-8102	756-8102	756-8102
757-011	757-011	757-011	757-011
-	-	-	-
-	-	-	-
757-080	757-080	757-080	757-080

Sensor/actuator boxes ▶ M12 socket; 5-pole; incl. ground

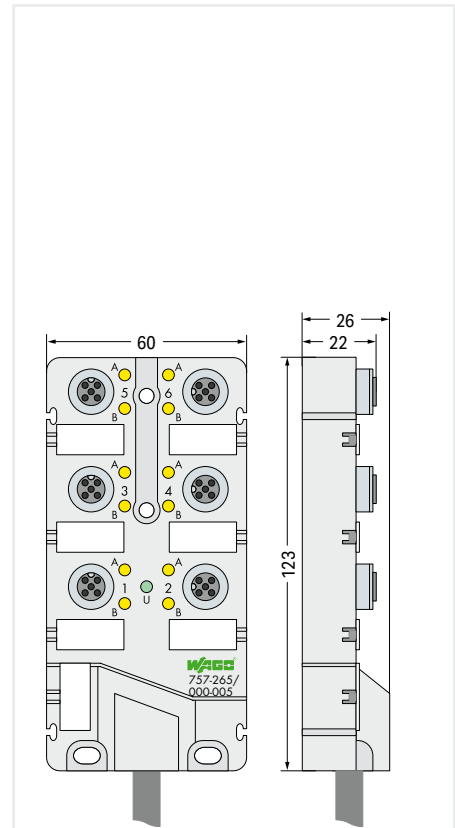
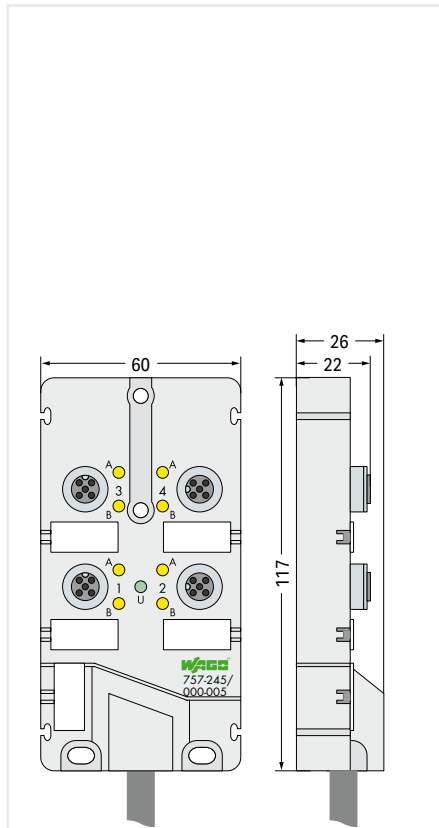

Connection technology: inputs/outputs
Item description
Version
Item no.
Order Text

4 x M12 socket; 5-pole; incl. ground	
M12 Sensor/Actuator Box; 4-port, 5-pole	
5 m connecting cable	10 m connecting cable
757-245/000-005	757-245/000-010
M12 S/A-Box; 4port; 5pole; 5m	M12 S/A-Box; 4port; 5pole; 10m

6 x M12 socket; 5-pole; incl. ground	
M12 Sensor/Actuator Box; 6-port, 5-pole	
5 m connecting cable	10 m connecting cable
757-265/000-005	757-265/000-010
M12 S/A-Box; 6port; 5pole; 5m	M12 S/A-Box; 6port; 5pole; 10m

Technical data
Connection technology: inputs/outputs
Pole number
Connection technology: trunk cable
Length of connection cable
Dimensions W x H x D
Approvals

4 x M12 socket; 5-pole; incl. ground	
5	
1 x Fixed connecting cable	
5 m	10 m
(60 x 26 x 117) mm	
E 175199; Ⓢ- OrdLoc; Class 2 Equipment; These components are designed to be supplied through Class 2 power supplies per UL 1310 or Class 2 transformers per UL 1585.	

6 x M12 socket; 5-pole; incl. ground	
5	
1 x Fixed connecting cable	
5 m	10 m
(60 x 26 x 123) mm	
E 175199; Ⓢ- OrdLoc; Class 2 Equipment; These components are designed to be supplied through Class 2 power supplies per UL 1310 or Class 2 transformers per UL 1585.	

For data sheet and additional information, see:
Accessories
Fiber-tip pen
M12 protective cap; for unused sockets
Marker card; not stretchable; snap-on type
Spacer module for sensor/actuator box; 4-way
Spacer module for sensor/actuator box; 6-way
Spacer module for sensor/actuator box; 8-way

wago.com/757-245/000-005	
Item no.	Item no.
210-110	210-110
756-8102	756-8102
757-011	757-011
757-040	757-040
-	-
-	-

wago.com/757-265/000-005	
Item no.	Item no.
210-110	210-110
756-8102	756-8102
757-011	757-011
-	-
757-060	757-060
-	-

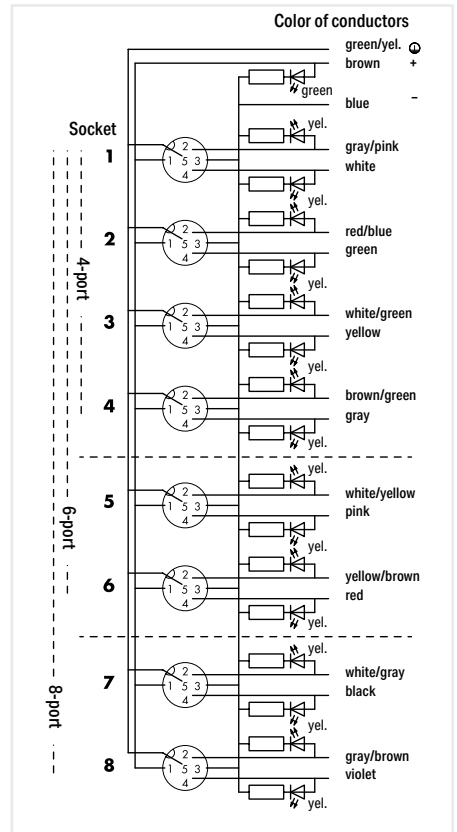
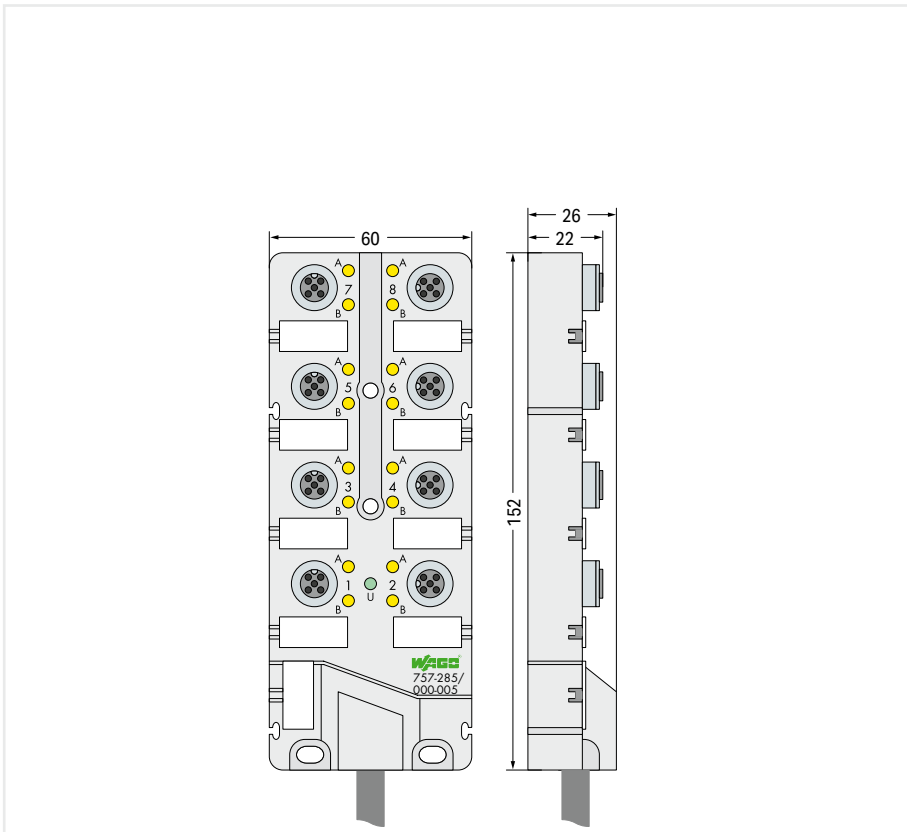

8 x M12 socket; 5-pole; incl. ground		
M12 Sensor/Actuator Box; 8-port, 5-pole		
5 m connecting cable	10 m connecting cable	25 m connecting cable
757-285/000-005	757-285/000-010	757-285/000-025
M12 S/A-Box; 8port; 5pole; 5m	M12 S/A-Box; 8port; 5pole; 10m	M12 S/A-Box; 8port; 5pole; 25m

8 x M12 socket; 5-pole; incl. ground		
5		
1 x Fixed connecting cable		
5 m	10 m	25 m
(60 x 26 x 152) mm		

E 175199; Ⓢ- OrdLoc; Class 2 Equipment; These components are designed to be supplied through Class 2 power supplies per UL 1310 or Class 2 transformers per UL 1585.

wago.com/757-285/000-005			
Item no.	Item no.	Item no.	Item no.
210-110	210-110	210-110	210-110
756-8102	756-8102	756-8102	756-8102
757-011	757-011	757-011	757-011
-	-	-	-
-	-	-	-
757-080	757-080	757-080	757-080

Sensor/actuator boxes ▶ M12 socket; 4-pole; incl. ground



757-185

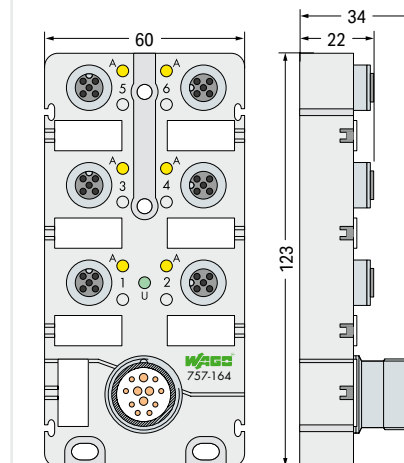
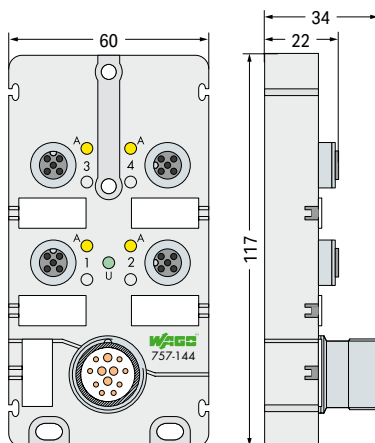

Connection technology: inputs/outputs

Item description

Item no.

Order Text

4 x M12 socket; 4-pole; incl. ground

M12 Sensor/Actuator Box; 4-port; 4-pole; M23 connector

757-144

M12 S/A-Box; 4port; 4pole; M23

6 x M12 socket; 4-pole; incl. ground

M12 Sensor/Actuator Box; 6-port; 4-pole; M23 connector

757-164

M12 S/A-Box; 6port; 4pole; M23

Technical data

Connection technology: inputs/outputs

Pole number

Connection technology: trunk cable

Dimensions W x H x D

Approvals

For data sheet and additional information, see:

Accessories

Fiber-tip pen

M12 protective cap; for unused sockets

Marker card; not stretchable; snap-on type

Spacer module for sensor/actuator box; 4-way

Spacer module for sensor/actuator box; 6-way

Spacer module for sensor/actuator box; 8-way

4 x M12 socket; 4-pole; incl. ground

4

1 x M23 plug; 12-pole

(60 x 34 x 117) mm

E 175199; OrdLoc; Class 2 Equipment; These components are designed to be supplied through Class 2 power supplies per UL 1310 or Class 2 transformers per UL 1585.

wago.com/757-144

Item no.

210-110

756-8102

757-011

757-040

-

-

6 x M12 socket; 4-pole; incl. ground

4

1 x M23 plug; 12-pole

(60 x 34 x 123) mm

E 175199; OrdLoc; Class 2 Equipment; These components are designed to be supplied through Class 2 power supplies per UL 1310 or Class 2 transformers per UL 1585.

wago.com/757-164

Item no.

210-110

756-8102

757-011

-

757-060

-

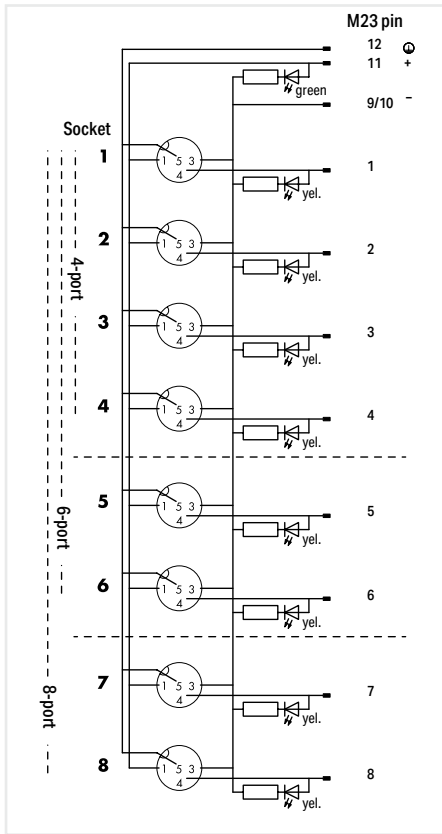
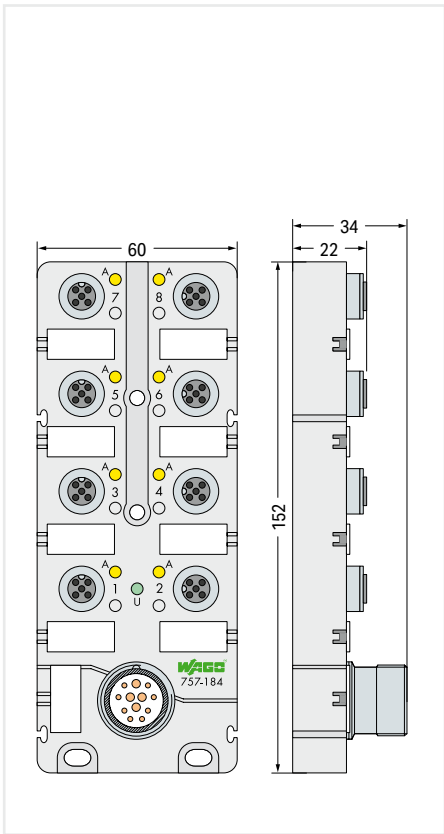

8 x M12 socket; 4-pole; incl. ground
 M12 Sensor/Actuator Box; 8-port; 4-pole; M23 connector
 757-184
 M12 S/A-Box; 8port; 4pole; M23

8 x M12 socket; 4-pole; incl. ground	4
1 x M23 plug; 12-pole	
(60 x 34 x 152) mm	
E 175199; OrdLoc; Class 2 Equipment; These components are designed to be supplied through Class 2 power supplies per UL 1310 or Class 2 transformers per UL 1585.	
wago.com/757-184	
Item no.	
	210-110
	756-8102
	757-011
	-
	-
	757-080

Sensor/actuator boxes ▶ M12 socket; 5-pole; incl. ground



757-185

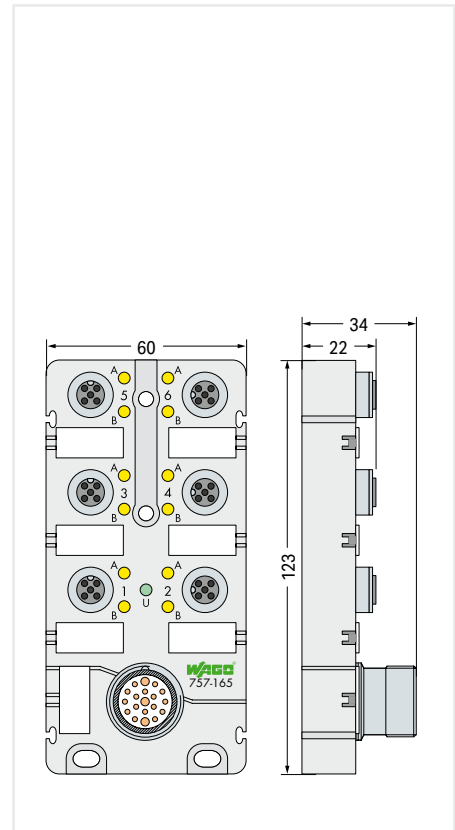
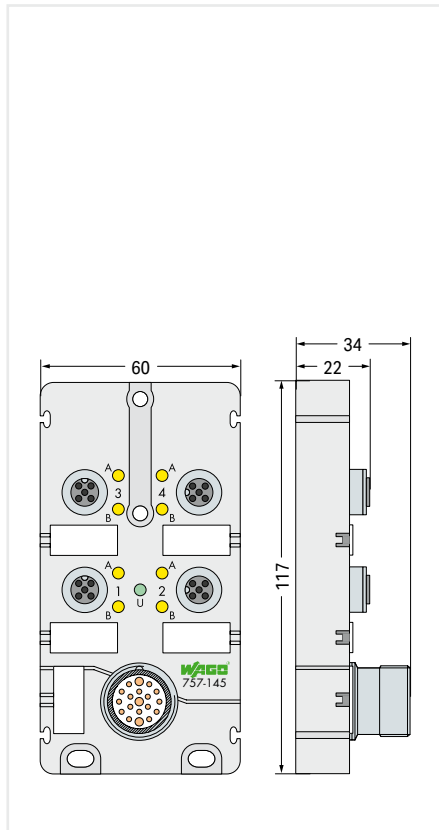

Connection technology: inputs/outputs
Item description
Item no.
Order Text

4 x M12 socket; 5-pole; incl. ground
M12 Sensor/Actuator Box; 4-port; 5-pole; M23 connector
757-145
M12 S/A-Box; 4port; 5pole; M23

6 x M12 socket; 5-pole; incl. ground
M12 Sensor/Actuator Box; 6-port; 5-pole; M23 connector
757-165
M12 S/A-Box; 6port; 5pole; M23

Technical data	
Connection technology: inputs/outputs	4 x M12 socket; 5-pole; incl. ground
Pole number	5
Connection technology: trunk cable	1 x M23 plug; 19-pole
Dimensions W x H x D	(60 x 34 x 117) mm
Approvals	E 175199; Ⓢ- OrdLoc; Class 2 Equipment; These components are designed to be supplied through Class 2 power supplies per UL 1310 or Class 2 transformers per UL 1585.
For data sheet and additional information, see:	wago.com/757-145

Technical data	
Connection technology: inputs/outputs	6 x M12 socket; 5-pole; incl. ground
Pole number	5
Connection technology: trunk cable	1 x M23 plug; 19-pole
Dimensions W x H x D	(60 x 34 x 123) mm
Approvals	E 175199; Ⓢ- OrdLoc; Class 2 Equipment; These components are designed to be supplied through Class 2 power supplies per UL 1310 or Class 2 transformers per UL 1585.
For data sheet and additional information, see:	wago.com/757-165

Technical data	
Connection technology: inputs/outputs	6 x M12 socket; 5-pole; incl. ground
Pole number	5
Connection technology: trunk cable	1 x M23 plug; 19-pole
Dimensions W x H x D	(60 x 34 x 123) mm
Approvals	E 175199; Ⓢ- OrdLoc; Class 2 Equipment; These components are designed to be supplied through Class 2 power supplies per UL 1310 or Class 2 transformers per UL 1585.
For data sheet and additional information, see:	wago.com/757-165

Accessories	
Fiber-tip pen	210-110
M12 protective cap; for unused sockets	756-8102
Marker card; not stretchable; snap-on type	757-011
Spacer module for sensor/actuator box; 4-way	757-040
Spacer module for sensor/actuator box; 6-way	-
Spacer module for sensor/actuator box; 8-way	-

Accessories	
Item no.	210-110
	756-8102
	757-011
	757-040
	-
	-

Accessories	
Item no.	210-110
	756-8102
	757-011
	-
	757-060
	-

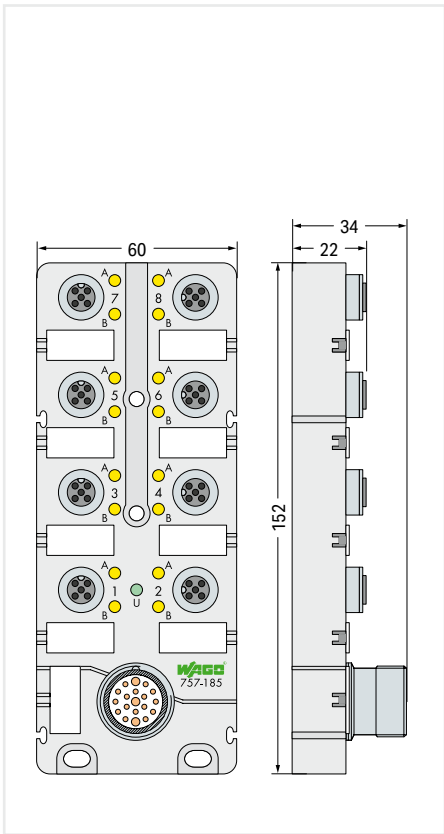

8 x M12 socket; 5-pole; incl. ground	
M12 Sensor/Actuator Box; 8-port; 5-pole; M23 connector	
	without LED
757-185	757-185/100-000
M12 S/A-Box; 8port; 5pole; M23	M12 S/A-Box; 8port; 5pole; M23; NL

8 x M12 socket; 5-pole; incl. ground
5

1 x M23 plug; 19-pole
(60 x 34 x 152) mm

E 175199; OrdLoc; Class 2 Equipment; These components are designed to be supplied through Class 2 power supplies per UL 1310 or Class 2 transformers per UL 1585.

wago.com/757-185

Item no.	Item no.
210-110	210-110
756-8102	756-8102
757-011	757-011
-	-
-	-
757-080	757-080

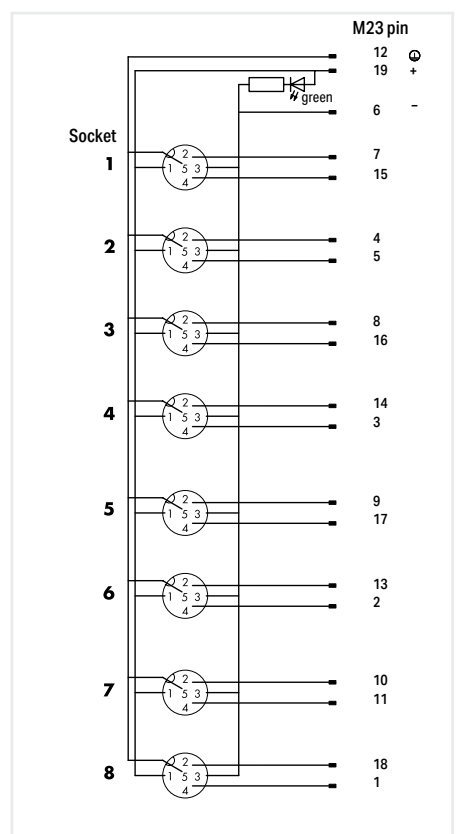
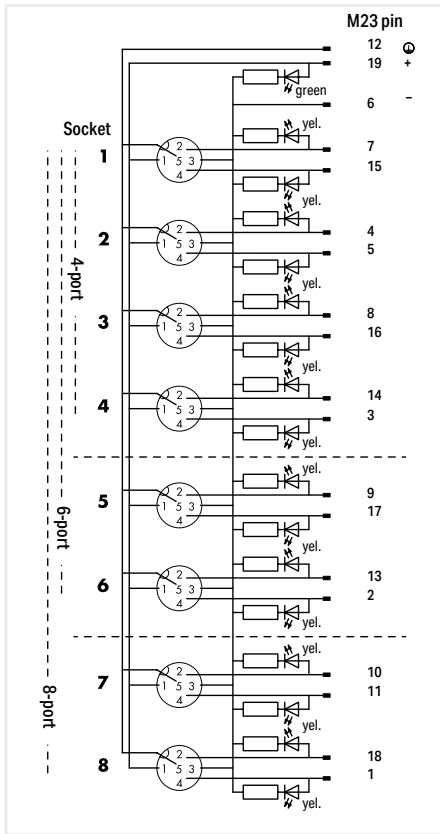

Sensor/actuator boxes ▶ M8 socket; 3-pole

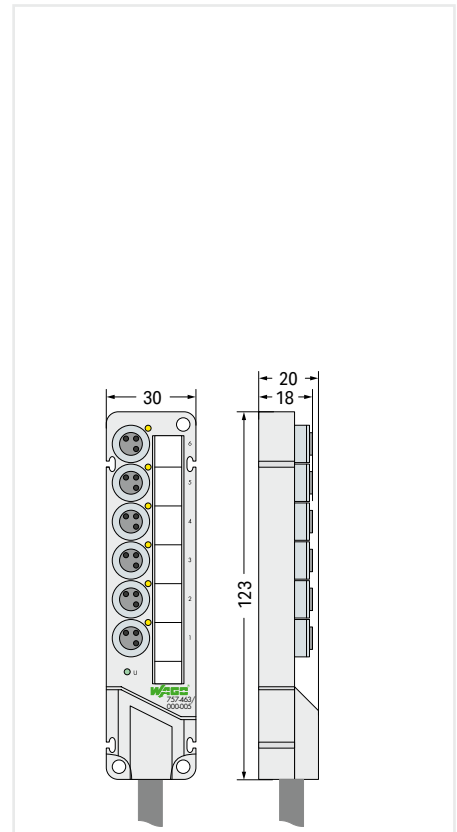
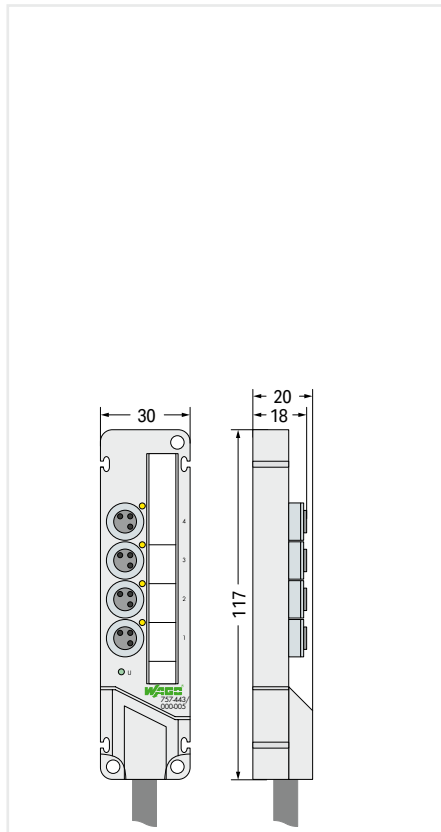

Connection technology: inputs/outputs
Item description
Version
Item no.
Order Text

4 x M8 socket; 3-pole	
M8 Sensor/Actuator Box; 4-port, 3-pole	
5 m connecting cable	10 m connecting cable
757-443/000-005	757-443/000-010
M8 S/A-Box; 4port; 3pole; 5m	M8 S/A-Box; 4port; 3pole; 10m

6 x M8 socket; 3-pole	
M8 Sensor/Actuator Box; 6-port, 3-pole	
5 m connecting cable	10 m connecting cable
757-463/000-005	757-463/000-010
M8 S/A-Box; 6port; 3pole; 5m	M8 S/A-Box; 6port; 3pole; 10m

Technical data

Connection technology: inputs/outputs
Pole number
Connection technology: trunk cable
Length of connection cable
Dimensions W x H x D
Approvals

4 x M8 socket; 3-pole	
3	
1 x Fixed connecting cable	
5 m	10 m
(30 x 20 x 117) mm	
E 175199; OrdLoc; Class 2 Equipment; These components are designed to be supplied through Class 2 power supplies per UL 1310 or Class 2 transformers per UL 1585.	

6 x M8 socket; 3-pole	
3	
1 x Fixed connecting cable	
5 m	10 m
(30 x 20 x 123) mm	
E 175199; OrdLoc; Class 2 Equipment; These components are designed to be supplied through Class 2 power supplies per UL 1310 or Class 2 transformers per UL 1585.	

For data sheet and additional information, see:

Accessories
Fiber-tip pen
M8 protective cap; for unused sockets
Spacer module for sensor/actuator box; 4-way
Marking strips; cut to a defined length; not stretchable; plain; snap-on type
Spacer module for sensor/actuator box; 6-way
Marking strips; cut to a defined length; not stretchable; plain; snap-on type
Spacer module for sensor/actuator box; 8-way
Marking strips; cut to a defined length; not stretchable; plain; snap-on type
Spacer module for sensor/actuator box; 10-way
Marking strips; not stretchable; snap-on type

wago.com/757-443/000-005	
Item no.	Item no.
210-110	210-110
756-8101	756-8101
757-040	757-040
757-041	757-041
-	-
-	-
-	-
-	-
-	-
-	-

wago.com/757-463/000-005	
Item no.	Item no.
210-110	210-110
756-8101	756-8101
-	-
-	-
757-060	757-060
757-061	757-061
-	-
-	-
-	-
-	-

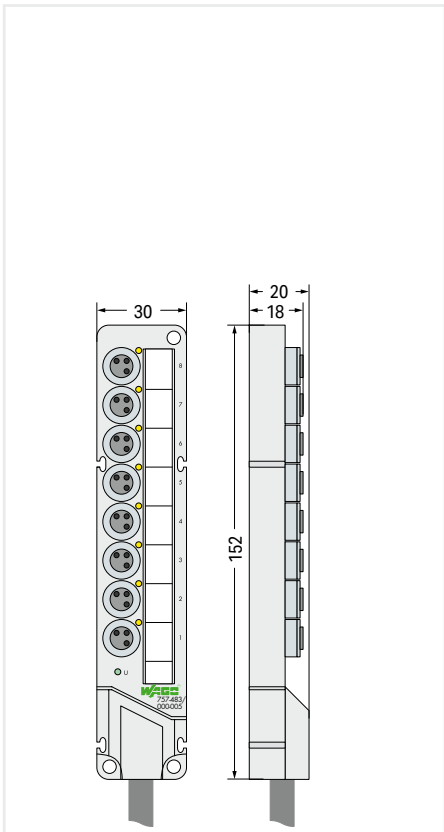

8 x M8 socket; 3-pole	
M8 Sensor/Actuator Box; 8-port, 3-pole	
5 m connecting cable	10 m connecting cable
757-483/000-005	757-483/000-010
M8 S/A-Box; 8port; 3pole; 5m	M8 S/A-Box; 8port; 3pole; 10m

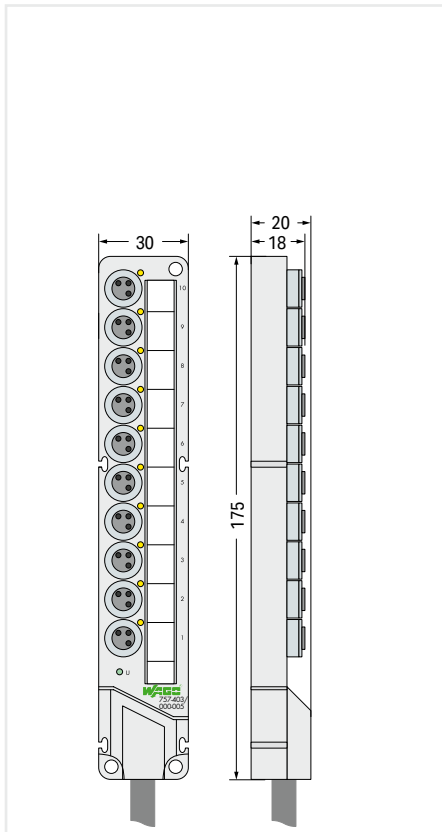

10 x M8 socket; 3-pole	
M8 Sensor/Actuator Box; 10-port, 3-pole	
5 m connecting cable	10 m connecting cable
757-403/000-005	757-403/000-010
M8 S/A-Box; 10port; 3pole; 5m	M8 S/A-Box; 10port; 3pole; 10m

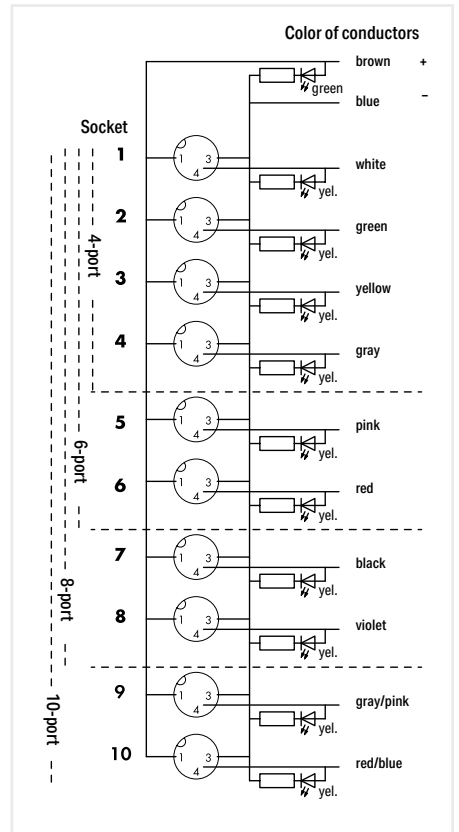

8 x M8 socket; 3-pole	
3	
1 x Fixed connecting cable	
5 m	10 m
(30 x 20 x 152) mm	
E 175199; OrdLoc; Class 2 Equipment; These components are designed to be supplied through Class 2 power supplies per UL 1310 or Class 2 transformers per UL 1585.	
wago.com/757-483/000-005	
Item no.	Item no.
210-110	210-110
756-8101	756-8101
-	-
-	-
-	-
-	-
757-080	757-080
757-081	757-081
-	-
-	-

10 x M8 socket; 3-pole	
3	
1 x Fixed connecting cable	
5 m	10 m
(30 x 20 x 175) mm	
E 175199; OrdLoc; Class 2 Equipment; These components are designed to be supplied through Class 2 power supplies per UL 1310 or Class 2 transformers per UL 1585.	
wago.com/757-403/000-005	
Item no.	Item no.
210-110	210-110
756-8101	756-8101
-	-
-	-
-	-
-	-
-	-
757-000	757-000
757-001	757-001

Sensor/actuator boxes ▶ M8 socket; 3-pole



757-303

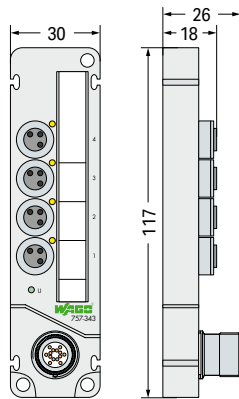

Connection technology: inputs/outputs
Item description
Item no.
Order Text

4 x M8 socket; 3-pole
M8 Sensor/Actuator Box; 4-port; 3-pole; M16 connector
757-343
M8 S/A-Box; 4port; 3pole; M16

Technical data
Connection technology: inputs/outputs
Pole number
Connection technology: trunk cable
Dimensions W x H x D
Approvals

4 x M8 socket; 3-pole
3
1 x M16 plug; 14-pole (30 x 26 x 117) mm
E 175199; OrdLoc; Class 2 Equipment; These components are designed to be supplied through Class 2 power supplies per UL 1310 or Class 2 transformers per UL 1585.

For data sheet and additional information, see:

wago.com/757-343

Accessories
Fiber-tip pen
M8 protective cap; for unused sockets
Spacer module for sensor/actuator box; 4-way
Marking strips; cut to a defined length; not stretchable; plain; snap-on type
Spacer module for sensor/actuator box; 6-way
Marking strips; cut to a defined length; not stretchable; plain; snap-on type
Spacer module for sensor/actuator box; 8-way
Marking strips; cut to a defined length; not stretchable; plain; snap-on type
Spacer module for sensor/actuator box; 10-way
Marking strips; not stretchable; snap-on type

Item no.
210-110
756-8101
757-040
757-041
-
-
-
-
-
-

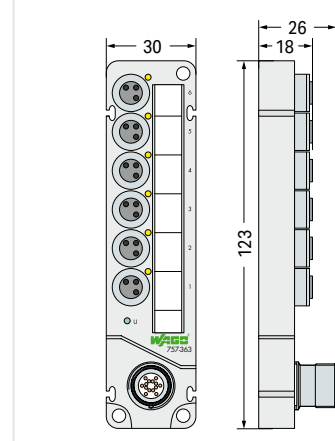

6 x M8 socket; 3-pole
M8 Sensor/Actuator Box; 6-port; 3-pole; M16 connector
757-363
M8 S/A-Box; 6port; 3pole; M16

6 x M8 socket; 3-pole
3
1 x M16 plug; 14-pole (30 x 26 x 123) mm
E 175199; OrdLoc; Class 2 Equipment; These components are designed to be supplied through Class 2 power supplies per UL 1310 or Class 2 transformers per UL 1585.

wago.com/757-363

Item no.
210-110
756-8101
-
-
757-060
757-061
-
-
-

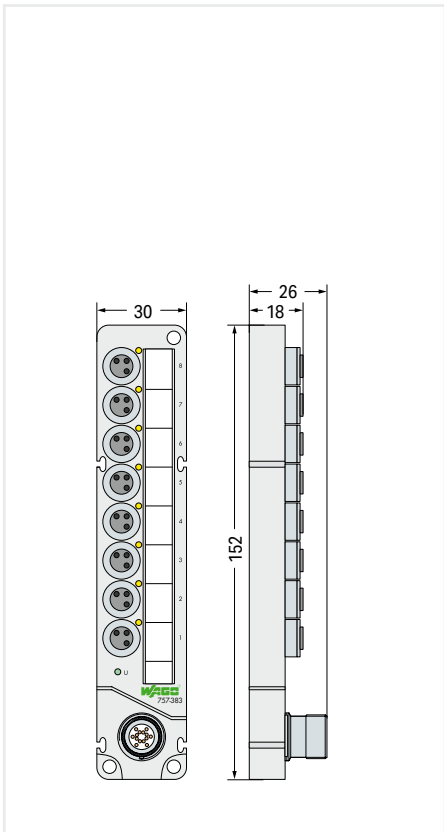

8 x M8 socket; 3-pole
M8 Sensor/Actuator Box; 8-port; 3-pole; M16 connector
757-383
M8 S/A-Box; 8port; 3pole; M16

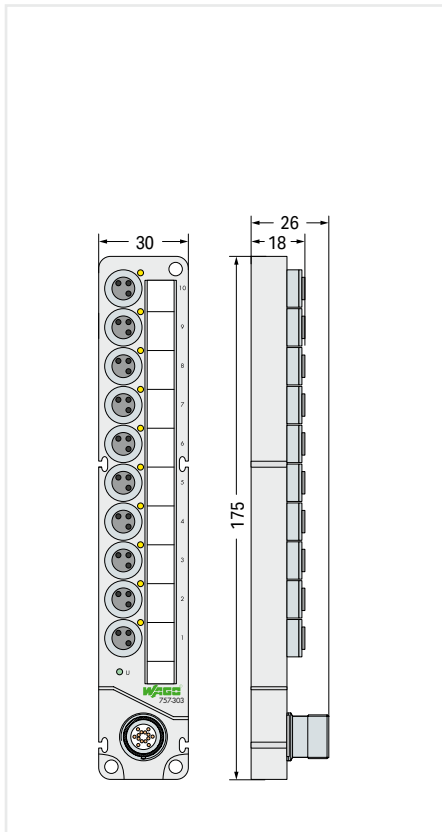

10 x M8 socket; 3-pole
M8 Sensor/Actuator Box; 10-port; 3-pole; M16 connector
757-303
M8 S/A-Box; 10port; 3pole; M16

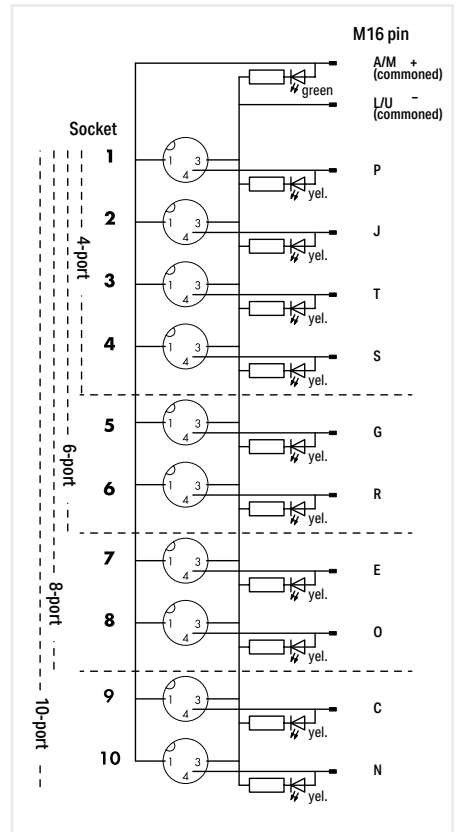

8 x M8 socket; 3-pole
 3
 1 x M16 plug; 14-pole
 (30 x 26 x 152) mm
 E 175199; OrdLoc; Class 2 Equipment; These components are designed to be supplied through Class 2 power supplies per UL 1310 or Class 2 transformers per UL 1585.
wago.com/757-383

Item no.
210-110
756-8101
-
-
-
-
757-080
757-081
-
-

10 x M8 socket; 3-pole
 3
 1 x M16 plug; 14-pole
 (30 x 26 x 175) mm
 E 175199; OrdLoc; Class 2 Equipment; These components are designed to be supplied through Class 2 power supplies per UL 1310 or Class 2 transformers per UL 1585.
wago.com/757-303

Item no.
210-110
756-8101
-
-
-
-
-
-
757-000
757-001

Sensor/Actuator Boxes; Accessories



Marker Card; not stretchable; snap-on type		
	Item No.	PU
for M12 Sensor/Actuator Box	757-011	1



Marking Strip; cut to specified length; not stretchable; plain; snap-on type		
for M8 Sensor/Actuator Box	Item No.	PU
4-port	757-041	100
6-port	757-061	100
8-port	757-081	100
10-port	757-001	100



Felt-Tip Pen		
	Item No.	PU
for permanent marking	210-110	1



Protective Caps (for covering unused sensor/actuator ports)		
	Item No.	PU
M8 Protective Cap	756-8101	10
M12 Protective Cap	756-8102	10



Spacer Module for Sensor/Actuator Box		
	Item No.	PU
4-port	757-040	10
6-port	757-060	10
8-port	757-080	10
10-port	757-000	10

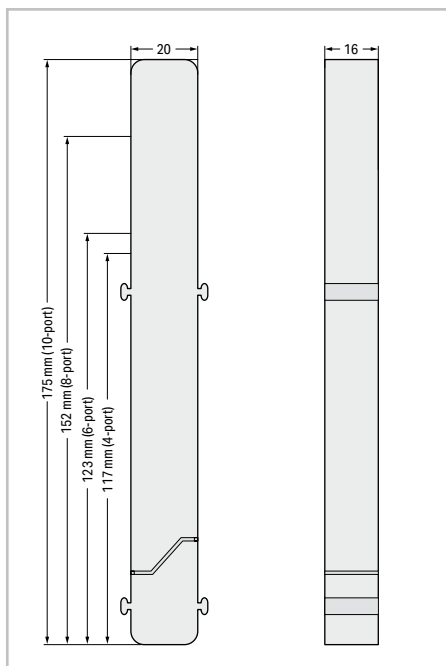

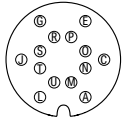

12



14-pole

Pin A, L: 0.75 mm²
Pin C ... J, N ... T: 0.34 mm²

A	brown	N	pink-brown
C	white-pink	O	violet
E	black	P	white
G	rose	R	red
J	green	S	gray
L	blue	T	yellow
M	bridged with A	U	bridged with L

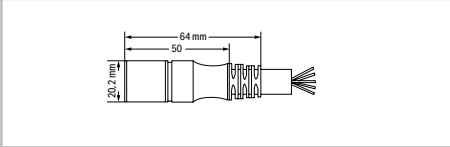
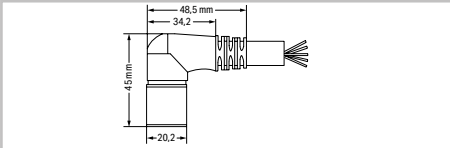
Operating voltage	150 V
Operating current	6 A (0.75 mm ²); 4 A (0.34 mm ²)
Rated surge voltage	1.2 kV
Drag chain suitability	≥ 2 million bending cycles
Surrounding air (operating) temperature (dynamic)	-30 ... +90 °C
Protection type	IP67
Cable diameter	9.1 mm ±0.2

Interconnection Cable; 14-pole; M16 socket (straight)		
Cable Length	Item No.	PU
5 m	756-3205/140-050	1
10 m	756-3205/140-100	1
15 m	756-3205/140-150	1



Interconnection Cable; 14-pole; M16 socket (angled)		
Cable Length	Item No.	PU
5 m	756-3206/140-050	1
10 m	756-3206/140-100	1
15 m	756-3206/140-150	1

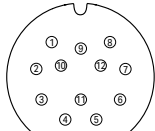

12-pole

Pin 9, 11, 12: 1.00 mm²;
Pin 1 ... 8: 0.34 mm²

1	white	9	blue
2	green	10	bridged with 9
3	yellow	11	brown
4	gray	12	green-yellow
5	rose		
6	red		
7	black		
8	violet		

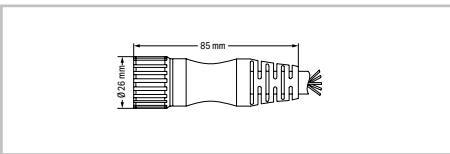
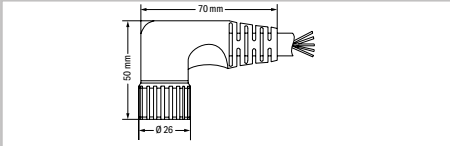
Operating voltage (max.)	300 V
Operating current	8 A
Rated surge voltage	≥ 2.0 kV rms
Drag chain suitability	≥ 2 million bending cycles
Surrounding air (operating) temperature (dynamic)	-25 ... +80 °C
Protection type	IP67
Cable diameter	9.3 mm ±0.3

Interconnection Cable; 12-pole; M23 socket (straight)		
Cable Length	Item No.	PU
5 m	756-3201/120-050	1
10 m	756-3201/120-100	1
15 m	756-3201/120-150	1



Interconnection Cable; 12-pole; M23 socket (angled)		
Cable Length	Item No.	PU
5 m	756-3202/120-050	1
10 m	756-3202/120-100	1
15 m	756-3202/120-150	1

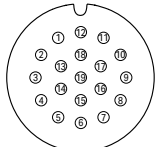

19-pole

Pin 6, 12, 19: 1.00 mm²;
Pin 1 ... 5, 7 ... 11, 13 ... 19: 0.34 mm²

1	violet	11	black
2	red	12	green-yellow
3	gray	13	yellow-brown
4	red-blue	14	brown-green
5	green	15	white
6	blue	16	yellow
7	gray-pink	17	rose
8	white-green	18	gray-brown
9	white-yellow	19	brown
10	white-gray		

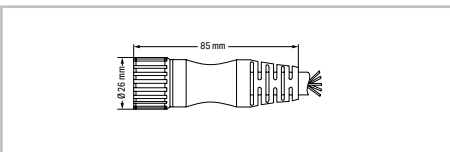
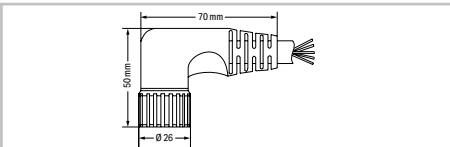
Operating voltage (max.)	300 V
Operating current	10 A (contacts 6, 12, 19); 8 A (remaining contacts)
Rated surge voltage	≥ 2.0 kV rms
Drag chain suitability	≥ 2 million bending cycles
Surrounding air (operating) temperature (dynamic)	-25 ... +80 °C
Protection type	IP67
Cable diameter	11.6 mm ±0.3

Interconnection Cable; 19-pole; M23 socket (straight)		
Cable Length	Item No.	PU
5 m	756-3203/190-050	1
10 m	756-3203/190-100	1
15 m	756-3203/190-150	1

Interconnection Cable; 19-pole; M23 socket (angled)		
Cable Length	Item No.	PU
5 m	756-3204/190-050	1
10 m	756-3204/190-100	1
15 m	756-3204/190-150	1





Accessories and Tools

Accessories and Tools

Contents

		Seite
	Power Supplies, 787 Series	Power Supplies Overview 654
		Backup Capacitor Module, DC/DC Converter 662
	System Wiring, 704, 706 Series	Interface Modules for System Wiring 663
		System Cables 664
	IP67 Cables and Connectors, 756 Series	Sensor/Actuator Cables and Distribution Connectors 666
		Configurable Connectors 674
		Torque Wrench M8 and M12 676
		ETHERNET Cables 677
	Configuration and Communication	Communication Cables 678
		Memory Cards 679
	Antennas, 758 Series	GSM/UMTS/LTE/Bluetooth®/WLAN 678
	Fieldbus Connectors, 750 Series	ETHERNET, PROFIBUS, PROFINET, CANopen, INTERBUS, CC-Link 680
	IP65 System Enclosures, 850 Series	Sheet Steel, Aluminum, Polyester 692
	DALI Multi-Master Accessories DALI Sensors and Room Control Units	DALI Multi-Sensor 698
		DALI Multi-Sensor Kit 700
		Power Supply to DALI Multi-Master 701
		DALI Sensors 702
		Room Control Units 703
	Multi-Port Device Taps for DeviceNet, 810 Series	704
	Shield Connection System, 790, 791 Series	706
	Marking Accessories	714
	DIN-Rails and Accessories, 210, 249, 209 Series	716
	Tools, Test and Measurement Devices, 206, 210 Series	719

WAGO Power Supplies Pro 2 – 2787 / 2789 Series

Illustration	Nominal Input Voltage	Output Current	Efficiency	Derating (> +55 °C and U _e < 230 VAC)	PowerBoost	MTBF (per IEC 61709)	Dimensions (W x H x D in mm)	Item No.
1-phase; TopBoost + PowerBoost; DI/DO; communication interface; 12 VDC output voltage								
	100 ... 240 VAC	10 A	≥ 93.8 %	-3 %/K	15 ADC (5 s)	> 1,200,000 h	35 x 130 x 130	2787-2134
	100 ... 240 VAC	15 A	≥ 95.3 %	-3 %/K	22.5 ADC (5 s)	> 1,200,000 h	70 x 130 x 130	2787-2135
1-phase; TopBoost + PowerBoost; DI/DO; communication interface; 24 VDC output voltage								
	100 ... 240 VAC	5 A	≥ 93.8 %	-3 %/K	7.5 ADC (5 s)	> 1,200,000 h	35 x 130 x 130	2787-2144
	100 ... 240 VAC	10 A	≥ 95.3 %	-3 %/K	15 ADC (5 s)	> 1,200,000 h	50 x 130 x 130	2787-2146
	100 ... 240 VAC	20 A	≥ 95.4 %	-3 %/K	30 ADC (5 s)	> 900,000 h	70 x 130 x 130	2787-2147
	200 ... 240 VAC	40 A	≥ 96 %	-3 %/K	60 ADC (5 s)	> 900,000 h	120 x 130 x 130	2787-2448
1-phase; TopBoost + PowerBoost; DI/DO; communication interface; 48 VDC output voltage								
	100 ... 240 VAC	5 A	≥ 95.3 %	-3 %/K	7.5 ADC (5 s)	> 900,000 h	50 x 130 x 130	2787-2154
	100 ... 240 VAC	10 A	≥ 95.3 %	-3 %/K	15 ADC (5 s)	> 800,000 h	70 x 130 x 130	2787-2157
3-phase; TopBoost + PowerBoost; DI/DO; communication interface; 24 VDC output voltage								
	(2 / 3) x 400 ... 500 VAC	5 A	≥ 92,5%	-3 %/K	7,5 ADC (5 s)	> 1.400.000 h	40 x 130 x 130	2787-2344
	(2 / 3) x 400 ... 500 VAC	10 A	≥ 93 %	-3 %/K	15 ADC (5 s)	> 1.000.000 h	50 x 130 x 130	2787-2346
	(2 / 3) x 400 ... 500 VAC	20 A	≥ 95,9 %	-3 %/K	30 ADC (5 s)	> 800.000 h	70 x 130 x 130	2787-2347
	(2 / 3) x 400 ... 500 VAC	40 A	≥ 96,1 %	-3 %/K	60 ADC (5 s)	> 800.000 h	120 x 130 x 130	2787-2348
3-phase; TopBoost + PowerBoost; DI/DO; communication interface; 48 VDC output voltage								
	(2/3) x 400 ... 500 VAC	10 A	≥ 95 %	-3 %/K	15 ADC (5 s)	> 900,000 h	70 x 130 x 130	2787-2357
	(2/3) x 400 ... 500 VAC	20 A	≥ 96 %	-3 %/K	30 ADC (5 s)	> 800,000 h	120 x 130 x 130	2787-2358

Accessories		
Illustration	Description	Item No.
	IO-Link Communication Module	2789-9080
	Modbus RTU Communication Module	2789-9015
	Ethernet/Modbus® TCP/Modbus® UDP/MQTT Communication Module	2789-9052
	Communication module; EtherNet/IP; communication capability	2789-9023



WAGO Power Supplies Pro 2
This new generation of professional power supplies is for applications requiring high performance, efficiency and reliability. These devices also offer tremendous added value thanks to flexible configuration and comprehensive monitoring via optional communication interface – can be used with the WAGO USB Communication Cable and IO-Link Communication Module.



Communication
The pluggable IO-Link communication modules allow continuous fieldbus communication, provide data (such as the current output current and voltage), and can also be configured or put in standby mode remotely.



Configuration
WAGO's new Interface Configuration Software offers both local/remote configuration and parameter setting, allowing the power supplies to be quickly and easily tailored to system requirements. The configuration function can be used to parameterize the power supply as an ECB.

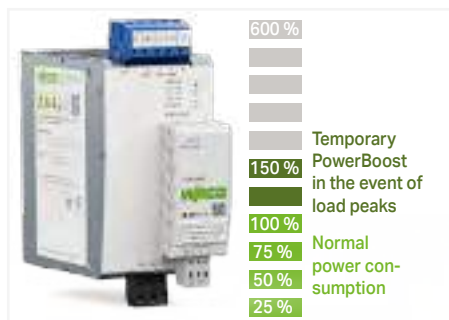

Load Management
Rapidly switching capacitive loads and high start-up currents are no problem, thanks to 150 % output power (PowerBoost) for five seconds. Output current up to 600 % for 15 ms provides reserves for rapidly and reliably tripping miniature circuit breakers. The ability to allow a specified output current to be exceeded for a configurable amount of time allows the Pro 2 Power Supply to work like a single-channel ECB.









Efficiency
Up to 96 % efficiency within a wide load range is the key to energy cost savings, reduced power losses and lower demand for control cabinet cooling. The CO₂ footprint is also dramatically reduced. WAGO's Pro 2 Power Supply can be permanently connected to the PLC via the communication module or a digital signal, allowing the power supply output to be switched off via a signal and standby mode to be used to save energy.



Robust Design
WAGO's Pro 2 Power Supplies can be started and operated from -40°C to +70°C, creating significant cost savings by reducing the need for control cabinet air conditioning. Featuring low derating capability above 60°C, the Pro 2 units are also highly robust, providing reliable operation in high-vibration and shock-prone applications. The power supplies can be operated at altitudes up to 5000 m, requiring no derating below 2000 m ASL.

WAGO Power Supplies Pro – 787 Series

Illustration	Nominal Input Voltage	Output Current	Efficiency	Derating	PowerBoost	MTBF (per IEC 61709)	Dimensions (W x H x D in mm)	Item No.
1-phase; TopBoost + PowerBoost; DC OK contact; 12 VDC output voltage								
	100 ... 240 VAC	6 A	≥ 83 %	-3 %/K (> +50 °C)	12 ADC (4 s); 9 ADC (8 s)	> 500,000 h	40 x 163 x 163	787-819
	100 ... 240 VAC	10 A	≥ 87.8 %	-3 %/K (> +50 °C)	20 ADC (4 s); 15 ADC (8 s)	> 500,000 h	57 x 163 x 163	787-821
	100 ... 240 VAC	15 A	≥ 87 %	-3 %/K (> +50 °C)	30 ADC (4 s); 22.5 ADC (8 s)	> 500,000 h	57 x 163 x 179	787-831
1-phase; TopBoost + PowerBoost; DC OK contact; 24 VDC output voltage								
	100 ... 240 VAC	3 A	≥ 87.8 %	-3 %/K (> +50 °C)	6 ADC (4 s); 4.5 ADC (8 s)	> 500,000 h	40 x 163 x 163	787-818
	100 ... 240 VAC	5 A	≥ 87.8 %	-3 %/K (> +50 °C)	10 ADC (4 s); 7.5 ADC (8 s)	> 500,000 h	57 x 163 x 163	787-822
	100 ... 240 VAC	10 A	≥ 90 %	-3 %/K (> +50 °C)	20 ADC (4 s); 15 ADC (8 s)	> 500,000 h	57 x 163 x 179	787-832
	100 ... 240 VAC	20 A	≥ 91 %	-3 %/K (> +50 °C)	30 ADC (4 s); 55 ADC (8 s)	> 500,000 h	97 x 171 x 187	787-834
1-phase; TopBoost + PowerBoost; DC OK contact; output voltage: 48 VDC								
	100 ... 240 VAC	5 A	≥ 91 %	-3 %/K (> +50 °C)	10 ADC (4 s); 7.5 ADC (8 s)	> 500,000 h	57 x 163 x 179	787-833
	100 ... 240 VAC	10 A	≥ 91 %	-3 %/K (> +50 °C)	17.5 ADC (4 s); 15 ADC (8 s)	> 500,000 h	97 x 171 x 187	787-835
3-phase; TopBoost + PowerBoost; DC OK contact; 24 VDC output voltage								
	(2/3) x 400 ... 500 VAC	10 A	≥ 91.7 %	-3 %/K (> +50 °C)	20 ADC (4 s); 15 ADC (16 s)	> 500,000 h	57 x 163 x 179	787-840
	(2/3) x 400 ... 500 VAC	20 A	≥ 92.9 %	-3 %/K (> +50 °C)	40 ADC (4 s); 30 ADC (16 s)	> 500,000 h	77 x 171 x 179	787-842
	(2/3) x 400 ... 500 VAC	40 A	≥ 93.6 %	-5 %/K (> +45 °C)	60 ADC (4 s); 50 ADC (16 s)	> 500,000 h	128 x 171 x 205	787-844
3-phase; TopBoost + PowerBoost; DC OK contact; 24 VDC output voltage; LineMonitor								
	(2/3) x 400 ... 500 VAC	10 A	≥ 91.7 %	-3 %/K (> +50 °C)	20 ADC (4 s); 15 ADC (16 s)	> 500,000 h	57 x 163 x 179	787-850
	(2/3) x 400 ... 500 VAC	20 A	≥ 92.9 %	-3 %/K (> +50 °C)	40 ADC (4 s); 30 ADC (16 s)	> 500,000 h	77 x 171 x 179	787-852
	(2/3) x 400 ... 500 VAC	40 A	≥ 93.6 %	-5 %/K (> +45 °C)	60 ADC (4 s); 50 ADC (16 s)	> 500,000 h	128 x 171 x 205	787-854
3-phase; TopBoost + PowerBoost; DC OK contact; output voltage: 48 VDC								
	(2/3) x 400 ... 500 VAC	10 A	≥ 93 %	-3 %/K (> +50 °C)	15 ADC (4 s); 12.5 ADC (16 s)	> 500,000 h	77 x 171 x 179	787-845
	(2/3) x 400 ... 500 VAC	20 A	≥ 94.4 %	-3 %/K (> +50 °C)	30 ADC (4 s); 25 ADC (16 s)	> 500,000 h	128 x 171 x 205	787-847



TopBoost

- Multiplies the nominal current for up to 50 ms
- Fast and reliable triggering of the secondary-side fusing via miniature circuit breakers or melting fuses in the event of a short circuit or overload

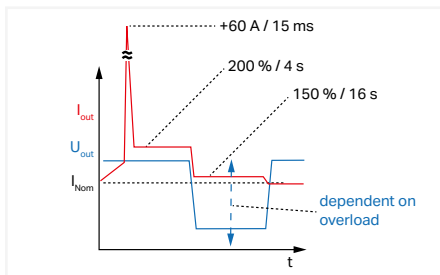

PowerBoost

- Provides 200 % of output power for 4 seconds
- Provides 150 % of output power for up to 16 seconds
- Ideal during start-up or switching of capacitive loads, valve clusters, motors, etc.
- Power reserve eliminates expensive oversizing



Innovative Communication

- LineMonitor with display and function keys
- Variable monitoring, e.g., current, voltage, phase position, operating hours and more
- Output voltage and overload behavior can be parameterized
- Integrated fault memory



RS-232 Serial Interface

- Front-side integrated interface communicates with a PC or PLC
- Free 759-850 Configuration Software and 759-851 Visualization Software can be downloaded at www.wago.com
- Free function blocks are available for various PLC systems
- 787-890 Serial Communication Cable is available as an accessory

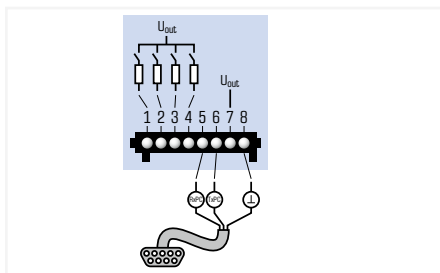

Active Signal Contacts

- Four active signal outputs for watchdog functions
- Each unit features a separate collective message for warning/fault
- Features two individually configurable signal outputs
- Free configuration software (Item No. 759-850) at www.wago.com

WAGO Power Supplies Classic – 787 Series

Illustration	Nominal Input Voltage	Output Current	Efficiency	Signal	Features	MTBF (per IEC 61709)	Dimensions (W x H x D in mm)	Item No.
1-phase; 12 VDC output voltage								
	100 ... 240 VAC	2 A	≥ 82 %	DC OK signal	NEC class 2	> 500,000 h	22.5 x 90 x 107.5	787-1601
	100 ... 240 VAC	4 A	≥ 86 %	DC OK signal	NEC class 2	> 500,000 h	45 x 90 x 107.5	787-1611
	100 ... 240 VAC	7 A	≥ 86 %	DC OK signal		> 500,000 h	52 x 90 x 119	787-1621
	100 ... 240 VAC	15 A	≥ 90 %	DC OK contact	TopBoost	> 500,000 h	55 x 27 x 172	787-1631
1-phase; 24 VDC output voltage								
	100 ... 240 VAC	1 A	≥ 86 %	DC OK signal	NEC class 2	> 500,000 h	22.5 x 90 x 107.5	787-1602
	100 ... 240 VAC	2 A	≥ 89 %	DC OK signal	NEC class 2	> 500,000 h	45 x 90 x 107.5	787-1606
	100 ... 240 VAC	4 A	≥ 89 %	DC OK signal		> 500,000 h	52 x 90 x 119.5	787-1616
	100 ... 240 VAC	3.8 A	≥ 87 %	DC OK signal	NEC class 2	> 500,000 h	52 x 90 x 119	787-1616/000-1000
	100 ... 240 VAC	5 A	≥ 89 %	DC OK contact	TopBoost	> 500,000 h	42 x 127 x 137.5	787-1622
	100 ... 240 VAC	10 A	≥ 91 %	DC OK contact	TopBoost	> 500,000 h	55 x 127 x 172	787-1632
	100 ... 240 VAC	20 A	≥ 92 %	DC OK contact	TopBoost	> 500,000 h	95 x 127 x 170	787-1634
1-phase; 48 VDC output voltage								
	100 ... 240 VAC	2 A	≥ 86 %	DC OK contact		> 500,000 h	52 x 90 x 119	787-1623
	100 ... 240 VAC	5 A	≥ 92 %	DC OK contact	TopBoost	> 500,000 h	55 x 127 x 172	787-1633
	100 ... 240 VAC	10 A	≥ 93 %	DC OK contact	TopBoost	> 500,000 h	95 x 127 x 170	787-1635
1-phase/2-phase; 24 VDC output voltage								
	(1 / 2) x 200 ... 500 VAC	5 A	≥ 89 %	DC OK contact	TopBoost	> 500,000 h	42 x 127 x 143.5	787-1628
	(1 / 2) x 200 ... 500 VAC	10 A	≥ 92.5 %	DC OK contact	TopBoost	> 500,000 h	55 x 127 x 146.5	787-1638
3-phase; 24 VDC output voltage								
	(2/3) x 400 ... 500 VAC	10 A	≥ 90 %	DC OK contact	TopBoost	> 500,000 h	55 x 127 x 171	787-1640
	(2/3) x 400 ... 500 VAC	20 A	≥ 92 %	DC OK contact	TopBoost	> 500,000 h	80 x 127 x 180	787-1642
	(2/3) x 400 ... 500 VAC	40 A	≥ 92 %	DC OK contact	TopBoost	> 500,000 h	126 x 127 x 198	787-1644



Communicative

- Green LED indicates output voltage availability
- Remote monitoring via DC OK signal or potential-free DC OK contact
- Easy commissioning and maintenance
- Quickly provides system information or machine status



Integrated TopBoost*

- Multiplies the nominal current
 - Fast and reliable triggering of the secondary-side fusing via circuit breakers or melting fuses in the event of a short circuit and overload
- * Only for 787-1622 ... -1628, -1631 ... -1638, -1640 ... -1644



Device Marking

- Marking field for fast and securely attached device identification
- Supports WAGO's WMB Multi Marking System (5 mm pin spacing)
- Supports WAGO Marking Strips, 11 mm wide

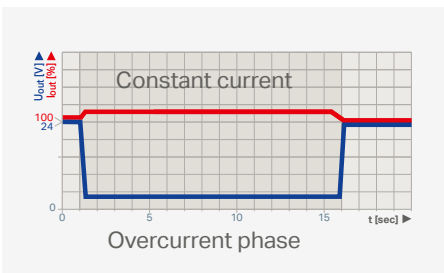

High Load-Carrying Capacity

- Constant current characteristic under overload conditions
- 110 % of output current with a lowered output voltage – even during a short circuit
- High capacitive loads can be reliably started

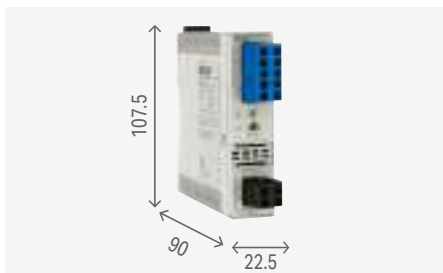

Slim Design

- Enclosure width reduced by up to 45% compared to previous Classic Power Supplies
- Saves valuable cabinet space

WAGO Power Supplies Eco 2 – 2687 Series / Eco – 787 Series

Illustration	Nominal Input Voltage	Output Current	Efficiency	Derating	Signal	MTBF (per IEC 61709)	Dimensions (W x H x D in mm)	Item No.
1-phase; 24 VDC output voltage; Eco 2								
	100 ... 240 VAC	1.25 A	≥ 88 %	-3 %/K (> +50 °C)		> 1.000.000 h	25 x 90 x 100	2687-2142
	100 ... 240 VAC	5 A	≥ 89 %	-3 %/K (> +50 °C)	DC OK contact	> 1.000.000 h	38 x 130 x 130	2687-2144
	100 ... 240 VAC	10 A	≥ 93 %	-3 %/K (> 50 °C)	DC OK contact	> 1.000.000 h	50 x 130 x 130	2687-2146
1-phase; 12 VDC output voltage; several mounting options								
	100 ... 240 VAC	2 A	≥ 86 %	-4 %/K (> +45 °C)		> 300,000 h	30 x 90 x 99	787-1701
	100 ... 240 VAC	4 A	≥ 86 %	-4 %/K (> +45 °C)		> 300,000 h	40 x 90 x 99	787-1711
	100 ... 240 VAC	8 A	≥ 86 %	-3 %/K (> +40 °C)		> 300,000 h	60 x 130 x 99	787-1721
1-phase; 24 VDC output voltage								
	110 ... 240 VAC	2.5 A	≥ 86 %	-3.3 %/K (> 50 °C)		480,000 h	50 x 92 x 136	787-712
	110 ... 240 VAC	5 A	≥ 86 %	-5.3 %/K (> 45 °C)		480,000 h	75 x 92 x 136	787-722
	110 ... 240 VAC	10 A	≥ 86 %	-2.3 %/K (> 40 °C)		480,000 h	110 x 92 x 136	787-732
	110 ... 240 VAC	20 A	≥ 90 %	-2.7 %/K (> 55 °C)	DC OK signal	> 250,000 h	115 x 136 x 144	787-734
	110 ... 240 VAC	40 A	≥ 90 %	-2.7 %/K (> 55 °C)	DC OK signal	> 250,000 h	170 x 136 x 150	787-736
1-phase; 24 VDC output voltage; several mounting options								
	100 ... 240 VAC	1.25 A	≥ 87 %	-4 %/K (> +45 °C)		> 300,000 h	30 x 90 x 99	787-1702
	100 ... 240 VAC	2.5 A	≥ 88 %	-4 %/K (> +45 °C)		> 300,000 h	40 x 90 x 99	787-1712
	100 ... 240 VAC	5 A	≥ 88 %	-3 %/K (> +45 °C)		> 300,000 h	60 x 130 x 99	787-1722
	100 ... 240 VAC	10 A	≥ 91 %	-4 %/K (> +45 °C)		> 300,000 h	70 x 165 x 99	787-1732
3-phase; 24 VDC output voltage								
	(2/3) x 400 ... 500 VAC	6.25 A	≥ 87 %	-2.5 %/K (> 50 °C)	DC OK contact	> 250,000 h	50 x 130 x 92	787-738
	(2/3) x 400 ... 500 VAC	10 A	≥ 89 %	-1.3 %/K (> 50 °C)	DC OK contact	> 250,000 h	65 x 130 x 130	787-740
	(2 / 3) x 400 ... 480 VAC	20 A	≥ 92 %	-2 %/K (> 45 °C)	DC OK contact	> 1,800,000 h	80 x 130 x 170	787-2742
	(2 / 3) x 400 ... 480 VAC	40 A	≥ 92,3 %	-2 %/K (> 45 °C)	DC OK contact	> 1,300,000 h	140 x 130 x 170	787-2744

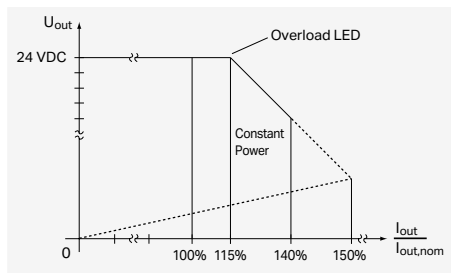

High Load-Carrying Capacity

- Overload warning from 1.15 times the nominal output current*
- Overload of up to 1.4 times the nominal current with a lowered output voltage (constant power)*
- Output shutdown in case of a low-resistance short circuit; also includes automatic restart

* Except for 787-17xx

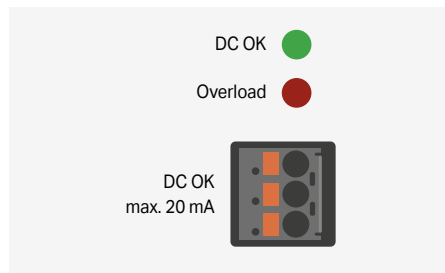

Status Monitoring

- Potential-isolated make contact signal, via bounce-free optocoupler* or PhotoMOS**
- Indicates whether an output voltage or an overload is present
- Ideal for remote monitoring

* Only for 787-734 ... -740

** Only for 787-2742, -2744



Fast Wiring

- Convenient, tool-free wiring thanks to lever-actuated terminal strips*
- Integrated test slot simplifies testing by eliminating conductor removal

* Only for 787-734 ... -740, -2742, -2744



Various Mounting Options

- Flexible mounting via DIN-rail adapter*
- Flexible installation via screw-mount clips*

* Only for 787-17xx



Highly Economical







- Triple the savings thanks to low purchase costs, easy installation and maintenance-free operation
- Budget-friendly for basic applications



EN 60335-1 Household Appliances Standard

- Power supplies with item numbers having the 787-17xx format meet the requirements of the household appliances standard

WAGO Power Supplies Compact – 787 Series

Illustration	Nominal Input Voltage	Output Current	Efficiency	Signal	MTBF (per IEC 61709)	Special Mounting Features	Dimensions (W x H x D in mm)	Item No.
1-phase; 5 VDC output voltage								
	100 ... 240 VAC	5.5 A	≥ 75 %		> 500,000 h	Overhead mounting	72 x 89 x 59	787-1020
1-phase; 12 VDC output voltage								
	100 ... 240 VAC	2 A	≥ 80 %		> 500,000 h	Overhead mounting	54 x 89 x 59	787-1001
	100 ... 240 VAC	4 A	≥ 85 %		> 500,000 h	Overhead mounting	72 x 89 x 59	787-1011
	100 ... 240 VAC	6 A	≥ 87 %		> 500,000 h	Overhead mounting	90 x 89 x 59	787-1021
1-phase; 12 VDC output voltage; with picoMAX connection technology (tool-free)								
	100 ... 240 VAC	2.5 A	≥ 88 %		> 500,000 h	Removable front panel	54 x 90 x 56	787-1201
	100 ... 240 VAC	5 A	≥ 88.5 %		> 500,000 h	Removable front panel	72 x 90 x 56	787-1211
	100 ... 240 VAC	8 A	≥ 91.5 %		> 500,000 h		108 x 90 x 56	787-1221
1-phase; 18 VDC output voltage								
	100 ... 240 VAC	1,25 A	≥ 88 %		> 2,500,000 h		36 x 90 x 62	787-2857
	100 ... 240 VAC	2.4 A	≥ 84 %		> 500,000 h	Overhead mounting	72 x 89 x 59	787-1017
1-phase; 24 VDC output voltage								
	100 ... 240 VAC	1.3 A	82 %		> 500,000 h	Overhead mounting	54 x 89 x 59	787-1002
	100 ... 240 VAC	2.5 A	88 %		> 500,000 h	Overhead mounting	72 x 89 x 59	787-1012
	100 ... 240 VAC	4 A	88 %		> 500,000 h	Overhead mounting	90 x 89 x 59	787-1022
1-phase; 24 VDC output voltage; with picoMAX connection technology (tool-free)								
	100 ... 240 VAC	0.5 A	83 %		> 700,000 h		18 x 90 x 55	787-1200
	110 ... 240 VAC	1.25 A	88 %		> 500,000 h		36 x 90 x 62	787-2850
	100 ... 240 VAC	1.3 A	87 %	DC OK signal	> 700,000 h	Removable front panel	54 x 90 x 56	787-1202
	100 ... 240 VAC	2.5 A	89 %	DC OK signal	> 500,000 h	Removable front panel	72 x 90 x 56	787-1212
	100 ... 240 VAC	4.2 A	90 %	DC OK signal	> 500,000 h	Removable front panel	108 x 90 x 56	787-1216
	100 ... 240 VAC	6 A	90 %	DC OK signal	> 500,000 h	Removable front panel	144 x 90 x 56	787-1226



Easy to Connect

- Vibration-proof, fast and maintenance-free CAGE CLAMP® connections
- Pre-assembly via pluggable picoMAX® connection technology*

* Only for 787-11xx, 787-12xx



DIN-Rail Built-In Installation

- Housing design per EN 43880, for installation in small distribution boards or meter panels



Various Mounting Options

- Easy mounting on DIN-rail
- Flexible installation via screw-mount clips also possible*

* Only for 787-12xx



Overhead Mounting

- Any type of mounting position is possible at reduced output power.
- Units can even be mounted overhead, e.g., in ceiling-mounted distribution boxes



Highly Economical





- Triple the savings thanks to low purchase costs, easy installation and maintenance-free operation
- Budget-friendly for basic applications



EN 60335-1 Household Appliances Standard

- Power supplies with item numbers having the 787-12xx format meet the requirements of the household appliances standard

WAGO DC/DC Converters – 787 / 288 Series

Illustration	Nominal Input Voltage	Nominal Output Voltage	Input Current	Output Current	Efficiency	Dimensions (W x H x D in mm)	Item No.
DC OK contact; in a compact 6 mm housing							
	24 VDC	5 VDC	≤ 0.34 A	0.5 A	≥ 82.5 %	6 x 97.8 x 94	787-2801
	24 VDC	10 VDC	≤ 0.42 A	0.5 A	≥ 89 %	6 x 97.8 x 94	787-2802
	24 VDC	12 VDC	≤ 0.5 A	0.5 A	≥ 90 %	6 x 97.8 x 94	787-2805
	48 VDC	24 VDC	≤ 0.34 A	0.5 A	≥ 91 %	6 x 97.8 x 94	787-2803
	24 VDC	5/10/12 VDC	≤ 0.5 A	0.5 A	≥ 82.5 %	6 x 97.8 x 94	787-2810
Output voltage: 12 VDC							
	24 VDC	12 VDC	≤ 3.39 A	4 A	≥ 84 %	45 x 90 x 107.5	787-1650
	72 VDC	12 VDC	≤ 0.79 A	4 A	≥ 85 %	72 x 89 x 59	787-1015/072-000
Output voltage: 18 VDC							
	24 VDC	18 VDC	≤ 0.37 A	0.4 A	82 %	50 x 25 x 85	288-895
Output voltage: 24 VDC							
	72 VDC	24 VDC	≤ 0.79 A	2 A	≥ 84 %	72 x 89 x 59	787-1014/072-000
	110 VDC	24 VDC	≤ 0.77 A	2 A	≥ 85 %	72 x 89 x 59	787-1014

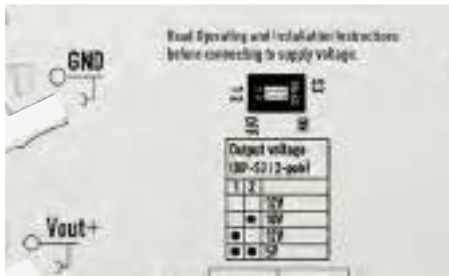

One Device for Many Applications

- Output voltage of the DC/DC Converter (787-2810) set via built-in DIP switch



Communicative

- Green LED indicates output voltage availability
- Remote monitoring via DC OK signal
- Easy commissioning and maintenance



Can Be Commoned with 857/2857 Series

- Full commoning of the supply voltage thanks to shared profile between the 787-28xx DC/DC Converters and the 857/2857 Series Relays and Signal Conditioners



The Industry's Most Compact

- "True" 6.0 mm (0.23 inch) width maximizes panel space



Suitable for Railway Applications per EN 50155

- Wide DC input voltage range
- Wide temperature range
- Protective coating

* Only 787-1014 & 787-101x/072-000

WAGO Electronic Circuit Breakers – 787 Series

Illustration	Output Current	Signaling	Features	Dimensions (W x H x D in mm)	Item No.
1 channel; 24 VDC input voltage					
	1 x 0.5 A (fixed setting)	1 x status LED (green/yellow/red/blue)	Communication capability	6 x 97.8 x 94	787-2861/050-000
	1 x 1 A (fixed setting)	1 x status LED (green/yellow/red/blue)	Communication capability	6 x 97.8 x 94	787-2861/100-000
	1 x 2 A (fixed setting)	1 x status LED (green/yellow/red/blue)	Communication capability	6 x 97.8 x 94	787-2861/200-000
	1 x 4 A (fixed setting)	1 x status LED (green/yellow/red/blue)	Communication capability	6 x 97.8 x 94	787-2861/400-000
	1 x 6 A (fixed setting)	1 x status LED (green/yellow/red/blue)	Communication capability	6 x 97.8 x 94	787-2861/600-000
	1 x 8 A (fixed setting)	1 x status LED (green/yellow/red/blue)	Communication capability	6 x 97.8 x 94	787-2861/800-000
	1 x 1 / 2 / 3 / 4 / 5 / 6 / 8 A	1 x status LED (green/yellow/red/blue)	Communication capability	6 x 97.8 x 94	787-2861/108-020
	1 x 0,5 A (fixed setting)	1 x LED Status (green/yellow/red)	Communication capability	6 x 97,8 x 94	787-3861/050-000
	1 x 1 A (fixed setting)	1 x LED Status (green/yellow/red)	Communication capability	6 x 97,8 x 94	787-3861/100-000
	1 x 2 A (fixed setting)	1 x LED Status (green/yellow/red)	Communication capability	6 x 97,8 x 94	787-3861/200-000
	1 x 4 A (fixed setting)	1 x LED Status (green/yellow/red)	Communication capability	6 x 97,8 x 94	787-3861/400-000
	1 x 6 A (fixed setting)	1 x LED Status (green/yellow/red)	Communication capability	6 x 97,8 x 94	787-3861/600-000
	1 x 8 A (fixed setting)	1 x LED Status (green/yellow/red)	Communication capability	6 x 97,8 x 94	787-3861/800-000
	1 x 0,5 / 1 / 1,5 / 2 / 2,5 / 3 / 3,5 / 4 A	1 x LED Status (green/yellow/red)	Communication capability	6 x 97,8 x 94	787-3861/004-020
	1 x 1 / 2 / 3 / 4 / 5 / 6 / 7 / 8 A	1 x LED Status (green/yellow/red)	Communication capability	6 x 97,8 x 94	787-3861/108-020
2 channels; 24 VDC input voltage					
	2 x 0.5 / 1 / 2 / 3 / 4 / 6 A	2 x LED status (green/red/orange)	Active current limitation; communication capability	45 x 90 x 115.5	787-1662/006-1000
	2 x 3.8 A	2 x LED status (green/red/orange)	Active current limitation; NEC class 2; communication capability	45 x 90 x 115.5	787-1662/004-1000
	2 x 2 / 3 / 4 / 6 / 8 / 10 A	2 x LED status (green/red/orange)	Communication capability	45 x 90 x 115.5	787-1662
	2 x 1 / 2 / 3 / 4 / 5 / 6 A	2 x LED status (green/red/orange)	Communication capability	45 x 90 x 115.5	787-1662/106-000
	2 x 2 / 3 / 4 / 6 / 8 / 10 A	2 x LED status (green/red/orange)	Signal contact; special configuration	45 x 90 x 115.5	787-1662/000-054
2 channels; 48 VDC input voltage					
	2 x 2 / 3 / 4 / 6 / 8 / 10 A	2 x LED status (green/red/orange)	Signal contact	45 x 90 x 115.5	787-1662/000-250
4 channels; 12 VDC input voltage					
	4 x 2 / 3 / 4 / 6 / 8 / 10 A	4 x LED status (green/red/orange)	Communication capability	45 x 90 x 115.5	787-1664/000-100
4 channels; 24 VDC input voltage					
	4 x 0.5 / 1 / 2 / 3 / 4 / 6 A	4 x LED status (green/red/orange)	Active current limitation; communication capability	45 x 90 x 115.5	787-1664/006-1000
	4 x 3.8 A	4 x LED status (green/red/orange)	Active current limitation; NEC class 2; communication capability	45 x 90 x 115.5	787-1664/004-1000
	4 x 2 / 4 / 6 / 8 / 10 / 12 A	4 x LED status (green/red/orange)	Active current limitation; communication capability	45 x 90 x 115.5	787-1664/212-1000
	4 x 0.5 / 1 / 2 / 3 / 4 / 6 A	4 x LED status (green/red/orange)	Active current limitation; signal contact; special configuration	45 x 90 x 115.5	787-1664/006-1054
	4 x 1 / 2 / 3 / 4 / 6 / 8 / 10 A	4 x LED status (green/red/orange)	IO-Link	45 x 90 x 115.5	787-1664/000-080
	4 x 2 / 3 / 4 / 6 / 8 / 10 A	4 x LED status (green/red/orange)	Communication capability	45 x 90 x 115.5	787-1664
	4 x 1 / 2 / 3 / 4 / 5 / 6 A	4 x LED status (green/red/orange)	Communication capability	45 x 90 x 115.5	787-1664/106-000
	4 x 1 / 2 / 3 / 4 / 5 / 6 A	4 x LED status (green/red/orange)	Communication capability; NPN signaling	45 x 90 x 115.5	787-1664/106-011
	4 x 2 / 3 / 4 / 6 / 8 / 10 A	4 x LED status (green/red/orange)	Communication capability; special configuration	45 x 90 x 115.5	787-1664/000-004
	4 x 2 / 3 / 4 / 6 / 8 / 10 A	4 x LED status (green/red/orange)	Signal contact; special configuration	45 x 90 x 115.5	787-1664/000-054
4 x 2 / 3 / 4 / 6 / 8 / 10 A	4 x LED status (green/red/orange)	Communication capability; NPN signaling	45 x 90 x 115.5	787-1664/000-011	
4 channels; 48 VDC input voltage					
	4 x 2 / 3 / 4 / 6 / 8 / 10 A	4 x LED status (green/red/orange)	Communication capability	45 x 90 x 115.5	787-1664/000-200
	4 x 2 / 3 / 4 / 6 / 8 / 10 A	4 x LED status (green/red/orange)	Signal contact	45 x 90 x 115.5	787-1664/000-250
8 channels; 24 VDC input voltage					
	8 x 0.5 / 1 / 2 / 3 / 4 / 6 A	8 x LED status (green/red/orange)	Active current limitation; communication capability	42 x 127 x 142.5	787-1668/006-1000
	8 x 0.5 / 1 / 2 / 3 / 4 / 6 A	8 x LED status (green/red/orange)	Active current limitation; signal contact; special configuration	42 x 127 x 142.5	787-1668/006-1054
	8 x 1 / 2 / 3 / 4 / 5 / 6 A	8 x LED status (green/red/orange)	Communication capability	42 x 127 x 142.5	787-1668/106-000
	8 x 2 / 3 / 4 / 6 / 8 / 10 A	8 x LED status (green/red/orange)	Communication capability	42 x 127 x 142.5	787-1668
	8 x 2 / 3 / 4 / 6 / 8 / 10 A	8 x LED status (green/red/orange)	Communication capability; special configuration	42 x 127 x 142.5	787-1668/000-004
	8 x 2 / 3 / 4 / 6 / 8 / 10 A	8 x LED status (green/red/orange)	Signal contact; special configuration	42 x 127 x 142.5	787-1668/000-054
	8 x 1 / 2 / 3 / 4 / 5 / 6 A	8 x LED status (green/red/orange)	Signal contact	42 x 127 x 142.5	787-1668/106-054
	8 x 1 / 2 / 3 / 4 / 6 / 8 / 10 A	8 x LED status (green/red/orange)	IO-Link	42 x 127 x 142.5	787-1668/000-080
8 channels; 48 VDC input voltage					
	8 x 2 / 3 / 4 / 6 / 8 / 10 A	8 x LED status (green/red/orange)	Communication capability	42 x 127 x 142.5	787-1668/000-200
	8 x 2 / 3 / 4 / 6 / 8 / 10 A	8 x LED status (green/red/orange)	Signal contact	42 x 127 x 142.5	787-1668/000-250

Uninterruptible Power Supplies (UPS); Battery Modules; Capacitive Buffer Modules; Redundancy Modules – 787 Series

Illustration	Nominal Input Voltage	Output Current	Efficiency	Buffer Time	Features	Dimensions (W x H x D in mm)	Item No.
--------------	-----------------------	----------------	------------	-------------	----------	------------------------------	----------

Power Supply with Integrated Charger and Controller; 1-phase; 24 VDC output voltage

	100 ... 240 VAC	5 A	≥ 88 %	1 s ... 20 min	Communication capability; Charging current ≤ 1 A	60 x 127 x 135.5	787-1675
---	-----------------	-----	--------	----------------	--	------------------	----------

UPS Charger and Controller; 24 VDC output voltage



	24 VDC	10 A	≥ 95 %	10 ... 600 s	LineMonitor; communication capability	40 x 163 x 163	787-870
	24 VDC	20 A	≥ 95 %	10 ... 600 s	LineMonitor; communication capability	57 x 171 x 163	787-875
	24 VDC	40 A	≥ 97 %	Load-dependent	Charging current ≤ 4 A	68 x 181 x 162	787-915

Illustration	Nominal Input Voltage	Output Current	Capacitance	Charging Current	Features	Dimensions (W x H x D in mm)	Item No.
--------------	-----------------------	----------------	-------------	------------------	----------	------------------------------	----------

Pure Lead Battery Module; 24 VDC output voltage

	24 VDC	20 A	2.5 Ah	≤ 5 A	Battery control -40 ... +60 °C	86 x 186 x 160	787-878/000-2500
	24 VDC	40 A	13 Ah	≤ 5 A	Battery control -40 ... +60 °C	217 x 186 x 199.5	787-878/001-3000

Lead Fleece Battery Module; 24 VDC output voltage

	24 VDC	7.5 A	1.2 Ah	≤ 0.3 A	Battery control -10 ... +40 °C	55 x 153 x 126.6	787-876
	24 VDC	20 A	3.2 Ah	≤ 0.8 A	Battery control	76.2 x 168 x 175.5	787-871
	24 VDC	40 A	7 Ah	≤ 1.8 A	Battery control	86 x 239 x 217.5	787-872
	24 VDC	40 A	12 Ah	≤ 3 A	Battery control	120.5 x 239 x 217.5	787-873
	24 VDC	5 A	0.8 Ah	0.2 A	Battery control -10 ... +40 °C	72 x 97 x 124	787-1671

Illustration	Nominal Input Voltage	Output Current	Buffer Time	Charging Time (typ.)	Features	Dimensions (W x H x D in mm)	Item No.
--------------	-----------------------	----------------	-------------	----------------------	----------	------------------------------	----------

Capacitive Buffer Module; 24 VDC output voltage



	24 VDC	10 A	0.06 ... 7.2 s	5 min	Communication capability	57 x 163 x 179	787-880
	24 VDC	20 A	0.17 ... 16.5 s	5 min	Communication capability	57 x 181 x 179	787-881
	24 VDC	40 A	0.3 ... 6.6 s	2.5 min		68 x 181 x 162	787-916

Illustration	Nominal Input Voltage	Output Current	Efficiency	Signaling	Features	Dimensions (W x H x D in mm)	Item No.
--------------	-----------------------	----------------	------------	-----------	----------	------------------------------	----------

Redundancy Module; 24 VDC output voltage

	2 x 24 VDC	25 A	≥ 96 %	Diode		50 x 130 x 92	787-783
	2 x 24 VDC	25 A	≥ 96 %	Diode	Ⓢ approval	50 x 130 x 92	787-783/000-040
	2 x 24 VDC	40 A	≥ 99.5 %	MOSFET	Communication capability	42 x 127 x 139.5	787-1685
	2 x 24 VDC	40 A	≥ 97 %	Diode	Communication capability	40 x 181 x 163	787-885
	2 x 24 VDC	76 A	≥ 97 %	Diode		83 x 130 x 153	787-785
	2 x 24 VDC	76 A	≥ 97 %	Diode	Ⓢ approval	83 x 130 x 153	787-785/000-040

Redundancy Module; 48 VDC output voltage

	2 x 48 VDC	40 A	≥ 97 %		Communication capability	40 x 181 x 163	787-886
---	------------	------	--------	--	--------------------------	----------------	---------

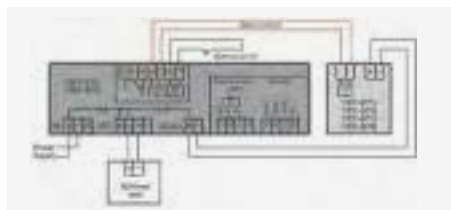

Battery Control Technology

- Allows continuous data exchange between intelligent Battery Modules (787-87x) and a UPS Charger/Controller
- Automatically detects a connected Battery Module (787-87x)
- Maximized battery life via temperature-controlled battery management

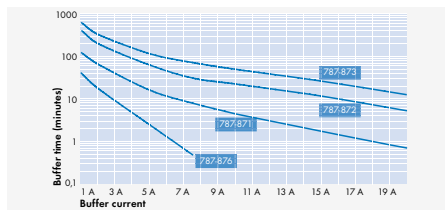

Buffer Time vs. Load Current

Different buffer times/currents can be achieved depending on the battery module selected. The example above shows a 7 A load current provided for approximately 30 seconds by a 787-870 UPS Charger/Controller (10 A) and 787-876 Battery Module.

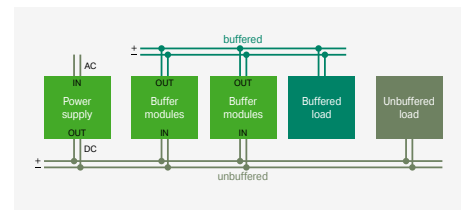

Parallel Connection Possible

- Multiple buffer modules can be connected in parallel to increase buffer time or load current

Backup Capacitor Module and DC/DC Converter



Item Description

Item No.

Technical Data

Nominal input voltage (DC) max.

Input current I_i (max.)

Nominal capacity

Weight

Dimensions W x H x D

Conductor connection

Conductor cross-sections

Strip length

For data sheet and additional information, see:

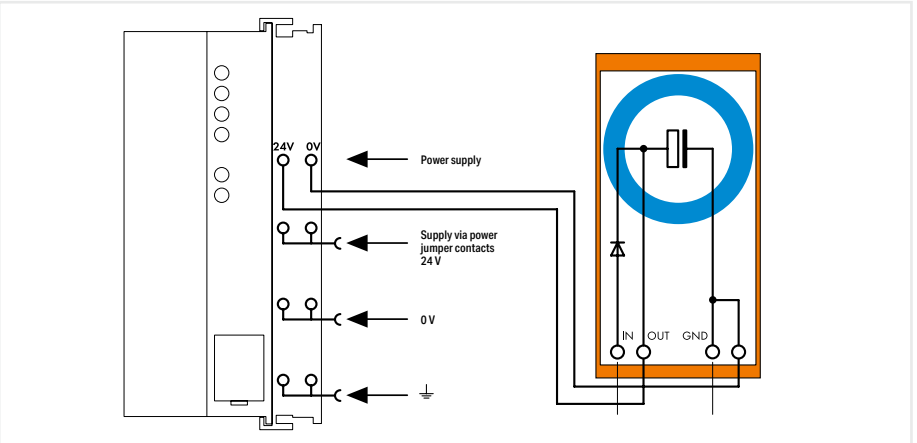

Component module with capacitor; 1 module;
Capacity: 10 mF; Nominal voltage: 24 VDC
288-824

This back-up capacitor module smoothes unstable 24 VDC power supplies for electronic modules in case the voltage tolerances mentioned in our data sheets cannot be ensured.

Reasons for voltage transients could be:

- Power interruptions (switching transients) on primary side
- Overloads on secondary side
- Switching of inductive or capacitive loads
- The back-up capacitor module is connected between the 24 V power supply and the electronic device to be protected.

Notice:

Using insufficiently smoothed and unregulated single-phase power supplies may lead to voltage increases by the back-up capacitor module.



Item Description

Item No.

Technical Data

Nominal input voltage (DC) max.

Input voltage range

Nominal output voltage (DC)

Nominal output current

Efficiency

Short-circuit-protected

Surrounding air temperature (operation)

Weight

Dimensions W x H x D

Conductor connection

Conductor cross-sections

Strip length

For data sheet and additional information, see:

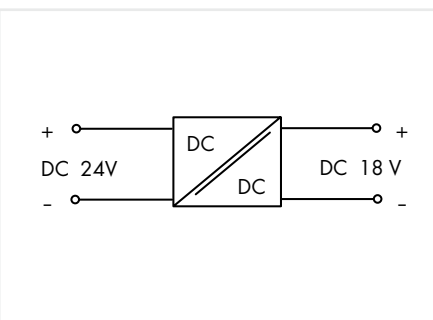

DC/DC Converter; 24 VDC input voltage; 18 VDC
output voltage; 0.4 A output current
288-895

24 VDC

18 ... 36 VDC

18 VDC (±2 %)

0.4 A

82 %

Yes

-25 ... +70 °C

76 g

50 x 25 x 85 mm; height from upper-edge of DIN-rail

CAGE CLAMP® (256 Series)

0.08 ... 2.5 mm² / 28 ... 12 AWG (THHN, THWN)

5 ... 6 mm / 0.24 inch

wago.com/288-895

WAGO System Wiring – 706 / 289 / 704 Series Interface Modules and Interface Cables

PLC WAGO I/O System 750						
PLC			WAGO Interface Cable		WAGO Interface Modules	
	Item No.	Qty.	Type	Qty.		
DI	PLC I/O Assembly					
	750-1400	16	DI	706-3057/300-XXXX	1	T16ES 1
DO	750-1500	16	DO	706-3057/300-XXXX	1	T16(E)S 1
	750-1502	8	DI	706-7753/302-XXXX	1	T8ES 1
	8	DO	T8(E)S 1			
DI/DO	750-1502	8	DI	706-3057/300-XXXX	1	T16ES 1
		8	DO			

PLC WAGO I/O System 753						
PLC			WAGO Interface Cable		WAGO Interface Modules	
	Item No.	Qty.	Type	Qty.		
DI	PLC I/O Assembly					
	753-430 (x1)	8	DI	706-7753/300-XXXX	1	T8ES 1
	753-430 (x2)	16	DI	706-7753/301-XXXX	1	T16ES 1
	753-431 (x1)	8	DI	706-7753/300-XXXX	1	T8ES 1
	753-431 (x2)	16	DI	706-7753/301-XXXX	1	T16ES 1
DO	753-530 (x1)	8	DO	706-7753/300-XXXX	1	T8(E)S 1
	753-530 (x2)	16	DO	706-7753/301-XXXX	1	T16(E)S 1
AI	753-453 (x1)	4	AI	706-7753/602-XXXX	1	A4ES 1
	753-453 (x2)	8	AI	706-7753/601-XXXX	1	A8ES 1
	753-455 (x1)	4	AI	706-7753/602-XXXX	1	A4ES 1
	753-455 (x2)	8	AI	706-7753/601-XXXX	1	A8ES 1
	753-457 (x1)	4	AI	706-7753/602-XXXX	1	A4ES 1
	753-457 (x2)	8	AI	706-7753/601-XXXX	1	A8ES 1
	753-459 (x1)	4	AI	706-7753/602-XXXX	1	A4ES 1
	753-459 (x2)	8	AI	706-7753/601-XXXX	1	A8ES 1
	753-553 (x1)	4	AO	706-7753/602-XXXX	1	A4ES 1
	753-553 (x2)	8	AO	706-7753/601-XXXX	1	A8ES 1
AO	753-555 (x1)	4	AO	706-7753/602-XXXX	1	A4ES 1
	753-555 (x2)	8	AO	706-7753/601-XXXX	1	A8ES 1
	753-557 (x1)	4	AO	706-7753/602-XXXX	1	A4ES 1
	753-557 (x2)	8	AO	706-7753/601-XXXX	1	A8ES 1
	753-559 (x1)	4	AO	706-7753/602-XXXX	1	A4ES 1
753-559 (x2)	8	AO	706-7753/601-XXXX	1	A8ES 1	

WAGO Interface Modules		
Type	Description	Item No.
T8ES	10-pole; without supply	289-611
	10-pole; with LED; 3-wire	704-2003
T8ESHT	12-pole (MCS); without LED; 2-wire; up to 250 V	704-3003
T8S	10-pole; with LED; electrical isolation: 5 A relay	704-5003
	10-pole; with LED; electrical isolation: 5 A relay; manual operation	704-5013
T16ES	20-pole; without supply	289-614
	20-pole; with LED; 1-wire	704-2004
	20-pole; with LED; 1-wire; channel isolation	704-2014
	20-pole; with LED; 2-wire	704-2024
	20-pole; with LED; 2-wire; channel fuse	704-2034
	20-pole; with LED; 2-wire; channel isolation	704-2044
	20-pole; with LED; 3-wire	704-2054
	20-pole; with LED; 3-wire; channel isolation	704-2064
	20-pole; with LED; 2-wire; 0 V/channel isolation	704-2074
	20-pole; without LED; 2-wire	704-2224
T16ESHT	2 x 10-pole (MCS); without LED; 2-wire; up to 250 V	704-3004
	20-pole; with LED; electrical isolation: 5 A relay	704-5004
T16S	20-pole; with LED; electrical isolation: 5 A relay	704-5024
	20-pole; with LED; electrical isolation: 5 A relay; channel fuse	704-5034
	20-pole; with LED; electrical isolation: 5 A relay; manual operation	704-5044
	20-pole; with LED; electrical isolation: 5 A relay; 0 V isolation; channel fuse	704-5054
	20-pole; with LED; electrical isolation: 5 A relay (2 u)	704-5064
	20-pole; with LED; electrical isolation: 5 A relay (1 a); 0 V/channel isolation; channel fuse	704-5074
A4/AO	15-pole D-sub; 2- and 4-wire	704-8002
	15-pole D-sub; 2- and 4-wire; isolation	704-8012
	25-pole D-sub; 2- and 4-wire	704-8003
	25-pole D-sub; 2- and 4-wire; isolation	704-8013
A8/TSX	25-pole D-sub; current and voltage signal	704-8023



I/O modules equipped with a ribbon cable connector provide easy and fast connection of WAGO Interface Modules to the WAGO I/O System. WAGO's pre-assembled system cables eliminate discrete wiring, while reducing costs for system wiring applications. Additionally, modules can be pre-wired, allowing the connection level to be relocated.

System Cables; for 750 Series WAGO I/O System 706 Series



When using more than 10 wires, the maximum current per wire must be reduced to 0.7 A.

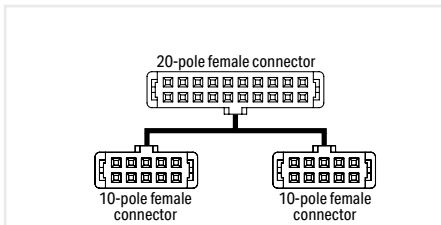

**System Cable; for 750 Series WAGO I/O System;
8 digital inputs and 8 digital outputs;
Conductor cross-section: 0.14 mm²**

Length	Item No.	PU
1 m	706-7753/302-100	1
2 m	706-7753/302-200	1
3 m	706-7753/302-300	1

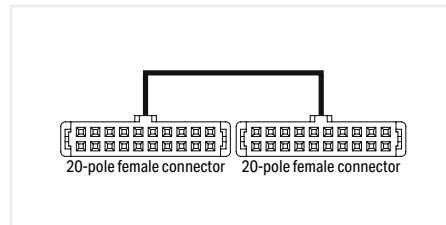

**System Cable; for Schneider TSX;
16 digital inputs or outputs;
Conductor cross-section: 0.14 mm²**

Length	Item No.	PU
1 m	706-3057/300-100	1
2 m	706-3057/300-200	1
3 m	706-3057/300-300	1

Technical Data

Connectors (side 1)	20-pole DIN 41651 connector; female connector / 2 x 10-pole DIN 41651 connector; female connector
Wire cross-section	0.14 mm ² LiYY
Color code	Per DIN VDE 47100
Current per wire (max.)	1 A
Operating voltage	≤ 35 VAC/DC
Surrounding air temperature (operation)	-20 ... +50 °C

Connectors (side 1)	20-pole DIN 41651 connector; female connector / 20-pole DIN 41651 connector; female connector
Wire cross-section	0.14 mm ² LiYY
Color code	Per DIN VDE 47100
Current per wire (max.)	1 A
Operating voltage	≤ 35 VAC/DC
Surrounding air temperature (operation)	-20 ... +50 °C

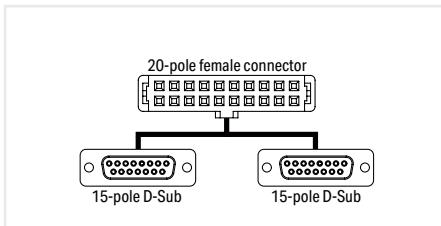

**System Cable; for 750 Series WAGO I/O System;
2 x 8 digital inputs or outputs;
Conductor cross-section: 0.14 mm²**

Length	Item No.	PU
1 m	706-7753/306-100	1
2 m	706-7753/306-200	1
3 m	706-7753/306-300	1

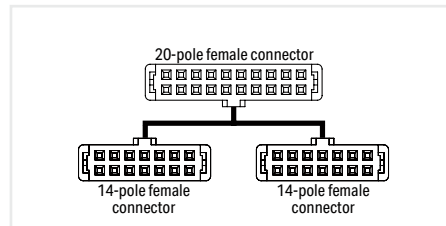

**System Cable; for 750 Series WAGO I/O System;
2 x 8 analog inputs or outputs;
Conductor cross-section: 0.14 mm²**

Length	Item No.	PU
1 m	706-7753/304-100	1
2 m	706-7753/304-200	1
3 m	706-7753/304-300	1

When using more than 10 wires, the maximum current per wire must be reduced to 0.7 A.

Technical Data

Connectors	20-pole DIN 41651 connector; female connector / 2 x 15-pole D-sub; socket
Wire cross-section	0.14 mm ² LiYY
Color code	Per DIN VDE 47100
Current per wire (max.)	1 A
Operating voltage	≤ 35 VAC/DC
Surrounding air temperature (operation)	-20 ... +50 °C

Connectors (side 1)	20-pole DIN 41651 connector; female connector / 2 x 14-pole DIN 41651 connector; female connector
Wire cross-section	0.14 mm ² LiYY
Color code	Per DIN VDE 47100
Current per wire (max.)	1 A
Operating voltage	≤ 35 VAC/DC
Surrounding air temperature (operation)	-20 ... +50 °C

System Cables; for 753 Series WAGO I/O System 706 Series



When using more than 10 wires, the maximum current per wire must be reduced to 0.7 A.

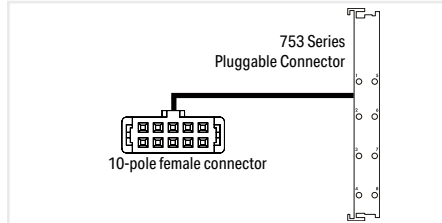

**System Cable; for 753 Series WAGO I/O System;
8 digital inputs or outputs;
Conductor cross-section: 0.14 mm²**

Length	Item No.	PU
1 m	706-7753/300-100	1
2 m	706-7753/300-200	1
3 m	706-7753/300-300	1

Technical Data

Connectors (side 1)	8-pole male connector (753 Series) / 10-pole DIN 41651 connector; female connector
Wire cross-section	0.14 mm ² LiYY
Color code	Per DIN VDE 47100
Current per wire (max.)	1 A
Operating voltage	≤ 35 VAC/DC
Surrounding air temperature (operation)	-20 ... +50 °C

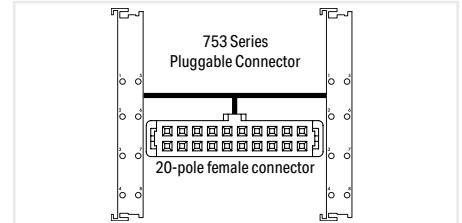

**System Cable; for 753 Series WAGO I/O System;
2 x 8 digital inputs or outputs;
Conductor cross-section: 0.14 mm²**

Length	Item No.	PU
1 m	706-7753/301-100	1
2 m	706-7753/301-200	1
3 m	706-7753/301-300	1

2 x 8-pole male connector (753 Series) / 20-pole DIN 41651 connector; female connector	
0.14 mm ² LiYY	
Per DIN VDE 47100	
1 A	
≤ 35 VAC/DC	
-20 ... +50 °C	



When using more than 10 wires, the maximum current per wire must be reduced to 1 A.

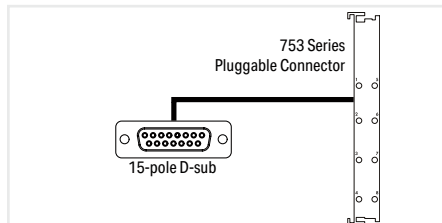

**System Cable; for 753 Series WAGO I/O System;
4 analog inputs or outputs;
Conductor cross-section: 0.25 mm²**

Length	Item No.	PU
1 m	706-7753/602-100	1
2 m	706-7753/602-200	1
3 m	706-7753/602-300	1

Technical Data

Connectors	8-pole male connector (753 Series) / 15-pole Mini D-sub; female connector
Wire cross-section	0.25 mm ² LiYCY
Color code	Per DIN VDE 47100
Current per wire (max.)	2 A
Operating voltage	≤ 35 VAC/DC
Surrounding air temperature (operation)	-20 ... +50 °C

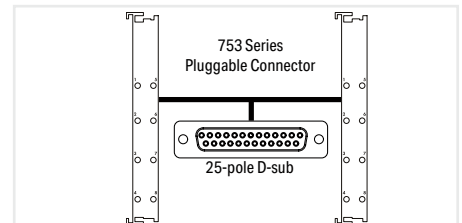

**System Cable; for 753 Series WAGO I/O System;
8 analog inputs or outputs;
Conductor cross-section: 0.25 mm²**

Length	Item No.	PU
1 m	706-7753/601-100	1
2 m	706-7753/601-200	1
3 m	706-7753/601-300	1

2 x 8-pole male connector (753 Series) / 25-pole Mini D-sub; female connector	
0.25 mm ² LiYCY	
Per DIN VDE 47100	
2 A	
≤ 35 VAC/DC	
-20 ... +50 °C	

IP67 Cables and Connectors



WAGO's 756 Series offers a wide range of accessories for connecting inductive or capacitive proximity switches, photoelectric sensors, flow monitors, limit switches, pressure switches and other devices.

The cables not only protect against the ingress of dust and water, but also protect against self-loosening due to vibration by working as a constructive "brake" thanks to the design of their coupling nuts. Injected cable entries also offer bend protection.

A distinction is made between cables assembled on one or both ends. Cables assembled on one end are often used where an exact cable length can not be determined or the installation of cables with connectors proves to be very difficult. These free-end cables can adapt to suit the installation's requirements. In contrast, cables assembled on both sides reduce assembly and installation times, cutting overall project costs.

Sensor/Actuator Cable; Fitted on One End



M8 Socket



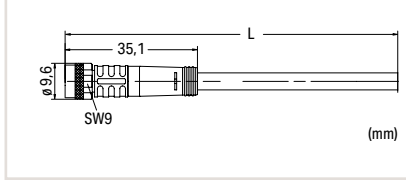

3-pole

Pin 1 ... 4: 0.34 mm²

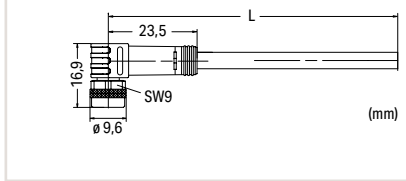
- 1 brown (+)
- 3 blue (-)
- 4 black (S)



M12 Socket

3-pole 4-pole 5-pole

Pin 1 ... 5: 0.34 mm²

- 1 brown (+)
- 2 white (Ö)
- 3 blue (-)
- 4 black (S)
- 5 gray

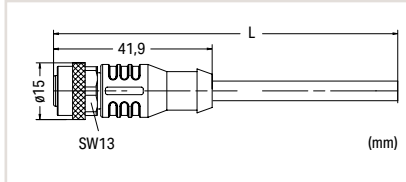
Operating voltage	60 VAC/DC
Operating current	4 A (max.)
Rated surge voltage	1.5 kV
Drag chain capability	≥ 2 million bending cycles
Surrounding air (operating) temperature (dynamic)	-25 ... +90 °C
Protection type	IP67
Cable diameter	4.1 mm ±0.2

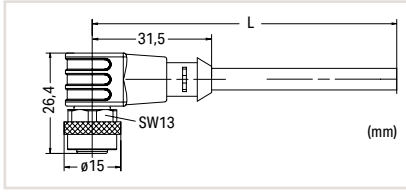
Sensor/Actuator Cable; M8 socket (straight)			
Pole No.	Cable Length	Item No.	PU
3-pole	1.5 m	756-5101/030-015	10
3-pole	5 m	756-5101/030-050	10
3-pole	10 m	756-5101/030-100	10

Sensor/Actuator Cable; M8 socket (angled)			
Pole No.	Cable Length	Item No.	PU
3-pole	1.5 m	756-5102/030-015	10
3-pole	5 m	756-5102/030-050	10
3-pole	10 m	756-5102/030-100	10

Operating voltage	250 VAC/DC
Operating current	4 A (max.)
Rated surge voltage	2.5 kV (3- and 4-pole); 1.5 kV (5-pole)
Drag chain capability	≥ 2 million bending cycles
Surrounding air (operating) temperature (dynamic)	-25 ... +90 °C
Protection type	IP67
Cable diameter	4.3 mm ±0.2 (3-pole); 4.7 mm ±0.2 (4-pole); 5.0 mm ±0.2 (5-pole); 6.5 mm ±0.2 (5-pole; shielded)

Sensor/Actuator Cable; M12 socket (straight)			
Pole No.	Cable Length	Item No.	PU
3-pole	1.5 m	756-5301/030-015	10
3-pole	5 m	756-5301/030-050	10
3-pole	10 m	756-5301/030-100	10
4-pole	1.5 m	756-5301/040-015	10
4-pole	5 m	756-5301/040-050	10
4-pole	10 m	756-5301/040-100	10
5-pole	1.5 m	756-5301/050-015	10
5-pole	5 m	756-5301/050-050	10
5-pole	10 m	756-5301/050-100	10
5-pole; shielded	1.5 m	756-5301/060-015	10
5-pole; shielded	5 m	756-5301/060-050	10
5-pole; shielded	10 m	756-5301/060-100	10

Sensor/Actuator Cable; M12 socket (angled)			
Pole No.	Cable Length	Item No.	PU
3-pole	1.5 m	756-5302/030-015	10
3-pole	5 m	756-5302/030-050	10
3-pole	10 m	756-5302/030-100	10
4-pole	1.5 m	756-5302/040-015	10
4-pole	5 m	756-5302/040-050	10
4-pole	10 m	756-5302/040-100	10
5-pole	1.5 m	756-5302/050-015	10
5-pole	5 m	756-5302/050-050	10
5-pole	10 m	756-5302/050-100	10
5-pole; shielded	1.5 m	756-5302/060-015	10
5-pole; shielded	5 m	756-5302/060-050	10
5-pole; shielded	10 m	756-5302/060-100	10

Sensor/Actuator Cable; Fitted on One End

M8 Plug



3-pole

Pin 1 ... 4: 0.34 mm²

- 1 brown (+)
- 3 blue (-)
- 4 black (S)

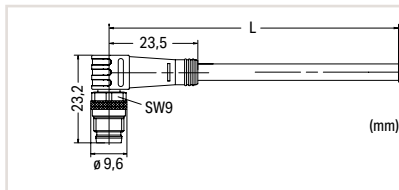
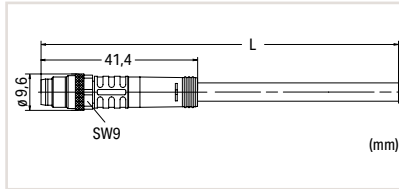

M12 Plug



3-pole



4-pole



5-pole

Pin 1 ... 5: 0.34 mm²

- 1 brown (+)
- 2 white (Ö)
- 3 blue (-)
- 4 black (S)
- 5 gray

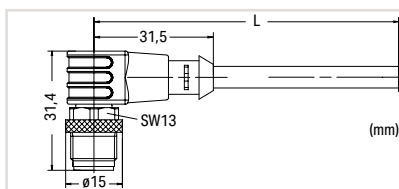
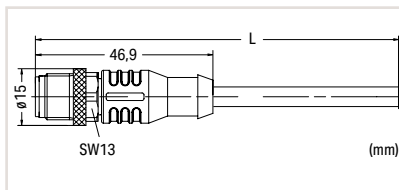

Operating voltage	60 VAC/DC
Operating current	4 A (max.)
Rated surge voltage	1.5 kV
Drag chain capability	≥ 2 million bending cycles
Surrounding air (operating) temperature (dynamic)	-25 ... +90 °C
Protection type	IP67
Cable diameter	4.1 mm ±0.2

Sensor/Actuator Cable; M8 plug (straight)

Pole No.	Cable Length	Item No.	PU
3-pole	1.5 m	756-5111/030-015	10
3-pole	5 m	756-5111/030-050	10
3-pole	10 m	756-5111/030-100	10

Sensor/Actuator Cable; M8 plug (angled)

Pole No.	Cable Length	Item No.	PU
3-pole	1.5 m	756-5112/030-015	10
3-pole	5 m	756-5112/030-050	10
3-pole	10 m	756-5112/030-100	10

Operating voltage	250 VAC/DC
Operating current	4 A (max.)
Rated surge voltage	2.5 kV (3- and 4-pole); 1.5 kV (5-pole)
Drag chain capability	≥ 2 million bending cycles
Surrounding air (operating) temperature (dynamic)	-25 ... +90 °C
Protection type	IP67
Cable diameter	4.3 mm ±0.2 (3-pole); 4.7 mm ±0.2 (4-pole); 5.0 mm ±0.2 (5-pole); 6.5 mm ±0.2 (5-pole; shielded)

Sensor/Actuator Cable; M12 plug (straight)

Pole No.	Cable Length	Item No.	PU
3-pole	1.5 m	756-5311/030-015	10
3-pole	5 m	756-5311/030-050	10
3-pole	10 m	756-5311/030-100	10
4-pole	1.5 m	756-5311/040-015	10
4-pole	5 m	756-5311/040-050	10
4-pole	10 m	756-5311/040-100	10
5-pole	1.5 m	756-5311/050-015	10
5-pole	5 m	756-5311/050-050	10
5-pole	10 m	756-5311/050-100	10
5-pole; shielded	1.5 m	756-5311/060-015	10
5-pole; shielded	5 m	756-5311/060-050	10
5-pole; shielded	10 m	756-5311/060-100	10

Sensor/Actuator Cable; M12 plug (angled)

Pole No.	Cable Length	Item No.	PU
3-pole	1.5 m	756-5312/030-015	10
3-pole	5 m	756-5312/030-050	10
3-pole	10 m	756-5312/030-100	10
4-pole	1.5 m	756-5312/040-015	10
4-pole	5 m	756-5312/040-050	10
4-pole	10 m	756-5312/040-100	10
5-pole	1.5 m	756-5312/050-015	10
5-pole	5 m	756-5312/050-050	10
5-pole	10 m	756-5312/050-100	10
5-pole; shielded	1.5 m	756-5312/060-015	10
5-pole; shielded	5 m	756-5312/060-050	10
5-pole; shielded	10 m	756-5312/060-100	10

Sensor/Actuator Cable; Fitted on One End

M12 Plug



8-pole, shielded

Pin 1 ... 8: 0.25 mm²

- 1 white
- 2 brown
- 3 green
- 4 yellow
- 5 gray
- 6 rose
- 7 blue
- 8 red
- Shield

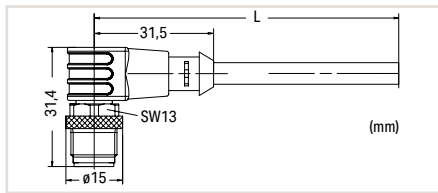
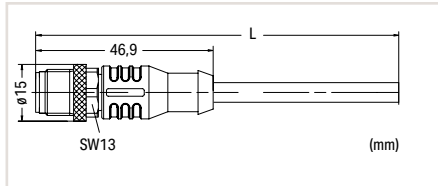

Operating voltage	250 VAC/DC
Operating current	4 A (max.)
Rated surge voltage	1.5 kV
Drag chain capability	≥ 2 million bending cycles
Surrounding air (operating) temperature (dynamic)	-25 ... +90 °C
Protection type	IP67
Cable diameter	6.3 mm ±0.2

Sensor/Actuator Cable; M12 plug (straight)

Pole No.	Cable Length	Item No.	PU
8-pole; shielded	1.5 m	756-5311/090-015	10
8-pole; shielded	5 m	756-5311/090-050	10
8-pole; shielded	10 m	756-5311/090-100	10

Sensor/Actuator Cable; M12 plug (angled)

Pole No.	Cable Length	Item No.	PU
8-pole; shielded	1.5 m	756-5312/090-015	10
8-pole; shielded	5 m	756-5312/090-050	10
8-pole; shielded	10 m	756-5312/090-100	10

Sensor/Actuator Cable; Fitted on Both Ends

M8 Socket **M8 Plug**

3-pole

Pin 1 ... 4: 0.34 mm²

- 1 brown (+)
- 3 blue (-)
- 4 black (S)

(mm)

(mm)

(mm)

(mm)

Operating voltage	60 VAC/DC
Operating current	4 A (max.)
Rated surge voltage	1.5 kV
Drag chain capability	≥ 2 million bending cycles
Surrounding air (operating) temperature (dynamic)	-25 ... +90 °C
Protection type	IP67
Cable diameter	4.1 mm ±0.2

Sensor/Actuator Cable; M8 socket (straight) – M8 plug (straight)

Pole No.	Cable Length	Item No.	PU
3-pole	1 m	756-5201/030-010	10
3-pole	2 m	756-5201/030-020	10

Sensor/Actuator Cable; M8 socket (straight) – M8 plug (angled)

Pole No.	Cable Length	Item No.	PU
3-pole	1 m	756-5202/030-010	10
3-pole	2 m	756-5202/030-020	10

Sensor/Actuator Cable; M8 socket (angled) – M8 plug (straight)

Pole No.	Cable Length	Item No.	PU
3-pole	1 m	756-5203/030-010	10
3-pole	2 m	756-5203/030-020	10

Sensor/Actuator Cable; M8 socket (angled) – M8 plug (angled)

Pole No.	Cable Length	Item No.	PU
3-pole	1 m	756-5204/030-010	10
3-pole	2 m	756-5204/030-020	10

M8 Socket **M12 Plug**

3-pole

4-pole

Pin 1 ... 4: 0.34 mm²

- 1 brown (+)
- 2 white (Ö)
- 3 blue (-)
- 4 black (S)

(mm)

(mm)

Operating voltage	60 VAC/DC
Operating current	4 A (max.)
Rated surge voltage	1.5 kV
Drag chain capability	≥ 2 million bending cycles
Surrounding air (operating) temperature (dynamic)	-25 ... +90 °C
Protection type	IP67
Cable diameter	4.1 mm ±0.2

Sensor/Actuator Cable; M8 socket (straight) – M12 plug (straight)

Pole No.	Cable Length	Item No.	PU
3-pole	1 m	756-5507/030-010	10
3-pole	2 m	756-5507/030-020	10
4-pole	1 m	756-5507/040-010	10
4-pole	2 m	756-5507/040-020	10

Sensor/Actuator Cable; M8 socket (straight) – M12 plug (angled)

Pole No.	Cable Length	Item No.	PU
3-pole	1 m	756-5508/030-010	10
3-pole	2 m	756-5508/030-020	10
4-pole	1 m	756-5508/040-010	10
4-pole	2 m	756-5508/040-020	10

Sensor/Actuator Cable; Fitted on Both Ends

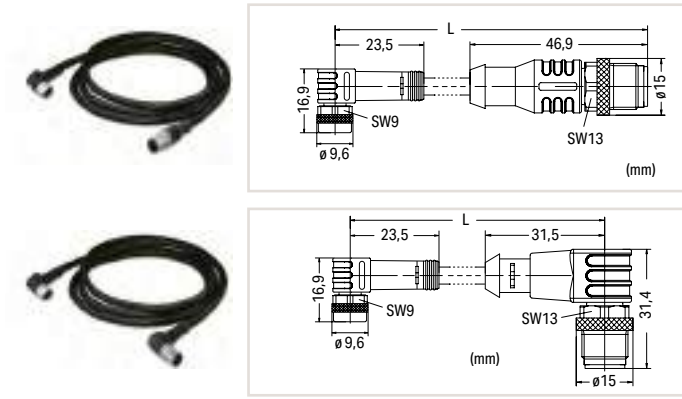

Sensor/Actuator Cable; M8 socket (angled) – M12 plug (straight)

Pole No.	Cable Length	Item No.	PU
3-pole	1 m	756-5509/030-010	10
3-pole	2 m	756-5509/030-020	10
4-pole	1 m	756-5509/040-010	10
4-pole	2 m	756-5509/040-020	10

Sensor/Actuator Cable; M8 socket (angled) – M12 plug (angled)

Pole No.	Cable Length	Item No.	PU
3-pole	1 m	756-5510/030-010	10
3-pole	2 m	756-5510/030-020	10
4-pole	1 m	756-5510/040-010	10
4-pole	2 m	756-5510/040-020	10

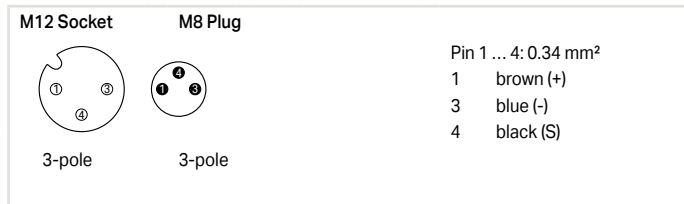

Operating voltage	60 VAC/DC
Operating current	4 A (max.)
Rated surge voltage	1.5 kV
Drag chain capability	≥ 2 million bending cycles
Surrounding air (operating) temperature (dynamic)	-25 ... +90 °C
Protection type	IP67
Cable diameter	4.1 mm ±0.2

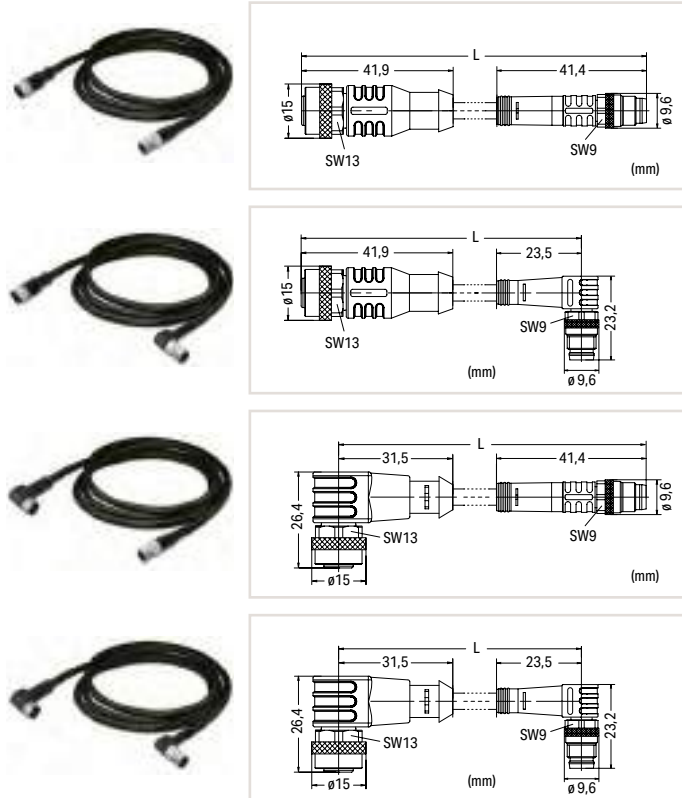

Sensor/Actuator Cable; M12 socket (straight) – M8 plug (straight)

Pole No.	Cable Length	Item No.	PU
3-pole	1 m	756-5501/030-010	10
3-pole	2 m	756-5501/030-020	10

Sensor/Actuator Cable; M12 socket (straight) – M8 plug (angled)

Pole No.	Cable Length	Item No.	PU
3-pole	1 m	756-5502/030-010	10
3-pole	2 m	756-5502/030-020	10

Sensor/Actuator Cable; M12 socket (angled) – M8 plug (straight)

Pole No.	Cable Length	Item No.	PU
3-pole	1 m	756-5503/030-010	10
3-pole	2 m	756-5503/030-020	10

Sensor/Actuator Cable; M12 socket (angled) – M8 plug (angled)

Pole No.	Cable Length	Item No.	PU
3-pole	1 m	756-5504/030-010	10
3-pole	2 m	756-5504/030-020	10

Sensor/Actuator Cable; Fitted on Both Ends

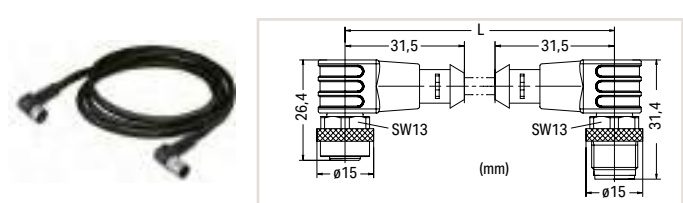
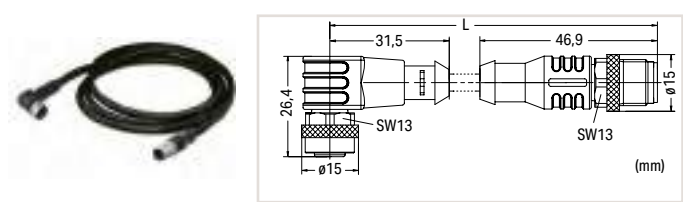
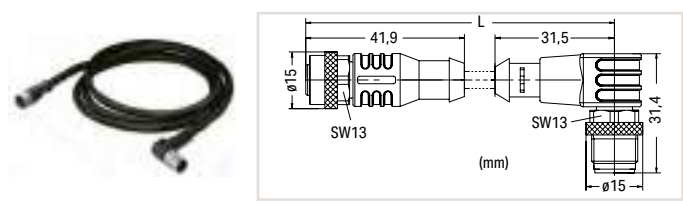
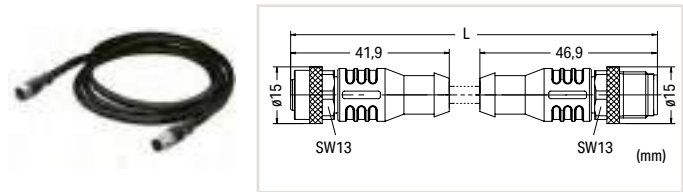
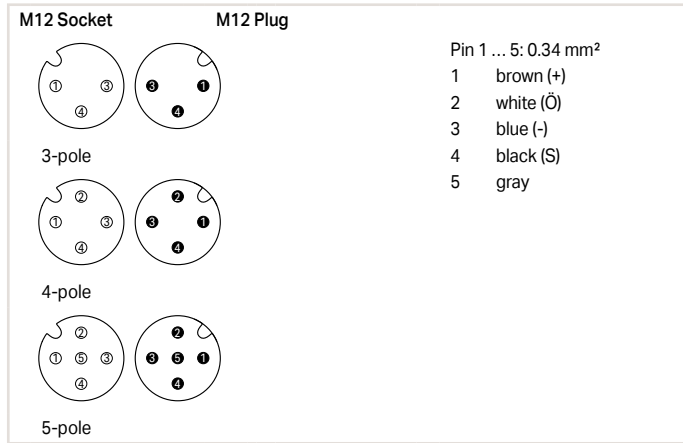

Operating voltage	250 VAC/DC
Operating current	4 A (max.)
Rated surge voltage	2.5 kV (3- and 4-pole); 1.5 kV (5-pole)
Drag chain capability	≥ 2 million bending cycles
Surrounding air (operating) temperature (dynamic)	-25 ... +90 °C
Protection type	IP67
Cable diameter	4.3 mm ±0.2 (3-pole); 4.7 mm ±0.2 (4-pole); 5.0 mm ±0.2 (5-pole); 6.5 mm ±0.2 (5-pole; shielded)

Sensor/Actuator Cable; M12 socket (straight) – M12 plug (straight)			
Pole No.	Cable Length	Item No.	PU
3-pole	1 m	756-5401/030-010	10
3-pole	2 m	756-5401/030-020	10
4-pole	1 m	756-5401/040-010	10
4-pole	2 m	756-5401/040-020	10
5-pole	1 m	756-5401/050-010	10
5-pole	2 m	756-5401/050-020	10
5-pole; shielded	1 m	756-5401/060-010	10
5-pole; shielded	2 m	756-5401/060-020	10

Sensor/Actuator Cable; M12 socket (straight) – M12 plug (angled)			
Pole No.	Cable Length	Item No.	PU
3-pole	1 m	756-5402/030-010	10
3-pole	2 m	756-5402/030-020	10
4-pole	1 m	756-5402/040-010	10
4-pole	2 m	756-5402/040-020	10
5-pole	1 m	756-5402/050-010	10
5-pole	2 m	756-5402/050-020	10
5-pole; shielded	1 m	756-5402/060-010	10
5-pole; shielded	2 m	756-5402/060-020	10

Sensor/Actuator Cable; M12 socket (angled) – M12 plug (straight)			
Pole No.	Cable Length	Item No.	PU
3-pole	1 m	756-5403/030-010	10
3-pole	2 m	756-5403/030-020	10
4-pole	1 m	756-5403/040-010	10
4-pole	2 m	756-5403/040-020	10
5-pole	1 m	756-5403/050-010	10
5-pole	2 m	756-5403/050-020	10
5-pole; shielded	1 m	756-5403/060-010	10
5-pole; shielded	2 m	756-5403/060-020	10

Sensor/Actuator Cable; M12 socket (angled) – M12 plug (angled)			
Pole No.	Cable Length	Item No.	PU
3-pole	1 m	756-5404/030-010	10
3-pole	2 m	756-5404/030-020	10
4-pole	1 m	756-5404/040-010	10
4-pole	2 m	756-5404/040-020	10
5-pole	1 m	756-5404/050-010	10
5-pole	2 m	756-5404/050-020	10
5-pole; shielded	1 m	756-5404/060-010	10
5-pole; shielded	2 m	756-5404/060-020	10

Sensor/Actuator Cable; Fitted on Both Ends; Distribution Connector

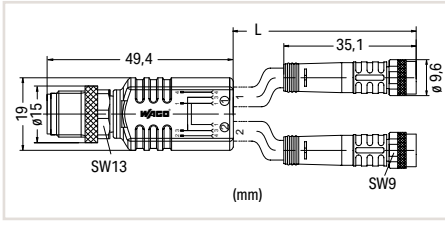
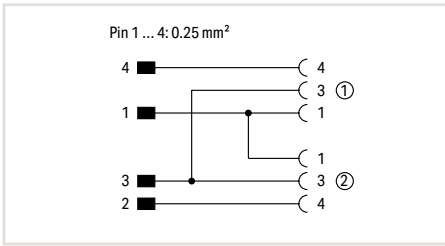
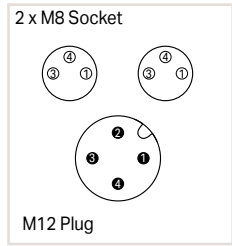

Operating voltage	60 VAC/DC
Operating current	4 A (max.)
Rated surge voltage	1.5 kV
Drag chain capability	≥ 2 million bending cycles
Surrounding air (operating) temperature (dynamic)	-25 ... +90 °C
Protection type	IP67
Cable diameter	4.1 mm ±0.2

Sensor/Actuator Cable; 2 x M8 socket (straight) – M12 plug (straight)			
Pole No.	Cable Length	Item No.	PU
4-pole	1 m	756-5513/040-010	10
4-pole	2 m	756-5513/040-020	10

Sensor/Actuator Cable; 2 x M8 socket (angled) – M12 plug (straight)			
Pole No.	Cable Length	Item No.	PU
4-pole	1 m	756-5514/040-010	10
4-pole	2 m	756-5514/040-020	10

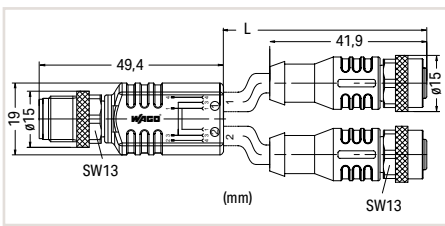
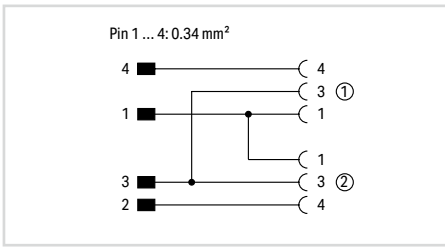
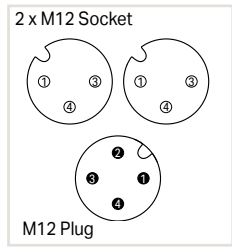

Operating voltage	250 VAC/DC
Operating current	4 A (max.)
Rated surge voltage	2.5 kV
Drag chain capability	≥ 2 million bending cycles
Surrounding air (operating) temperature (dynamic)	-25 ... +90 °C
Protection type	IP67
Cable diameter	4.7 mm ±0.2

Sensor/Actuator Cable; 2 x M12 socket (straight) – M12 plug (straight)			
Pole No.	Cable Length	Item No.	PU
4-pole	1 m	756-5516/040-010	10
4-pole	2 m	756-5516/040-020	10

Sensor/Actuator Cable; 2 x M12 socket (angled) – M12 plug (straight)			
Pole No.	Cable Length	Item No.	PU
4-pole	1 m	756-5517/040-010	10
4-pole	2 m	756-5517/040-020	10

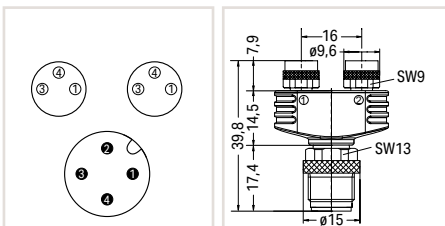

Distribution Connector M8/M12		
	Item No.	PU
Accessories; M12/M8 Distribution Connector	756-9301/040-000	1

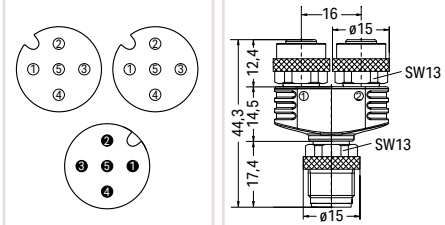
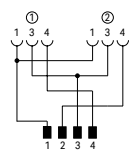

Distribution Connector M12/M12		
	Item No.	PU
Accessories; M12/M12 Distribution Connector	756-9301/050-000	1

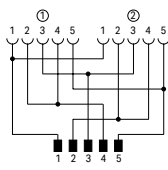

Configurable Connector



Connectable cable:
 Ø 4 ... 5 mm
 0.14 ... 0.34 mm²

3-pole

M8 Plug, Straight and Angled		
	Item No.	PU
Configurable Connector; 3-pole; M8 plug (straight); IDC technology	756-9102/030-000	5
Configurable Connector; 3-pole; M8 plug (angled); IDC technology	756-9105/030-000	5



Connectable cable:
 Ø 4 ... 5 mm
 0.14 ... 0.34 mm²

3-pole

M8 Socket, Straight and Angled		
	Item No.	PU
Configurable Connector; 3-pole; M8 socket (straight); IDC technology	756-9112/030-000	5
Configurable Connector; 3-pole; M8 socket (angled); IDC technology	756-9115/030-000	5



Connectable cable:
 Ø 4 ... 6 mm/0.25 ... 0.75 mm² (Screw clamp technology)
 Ø 4 ... 6 mm/0.14 ... 0.50 mm² (Spring clamp technology)

4-pole
5-pole

M12 Plug, Straight and Angled		
	Item No.	PU
Configurable Connector; 4-pole; M12 plug (straight); Screw connection technology	756-9201/040-000	5
Configurable Connector; 4-pole; M12 plug (angled); Screw connection technology	756-9204/040-000	5
Configurable Connector; 4-pole; M12 plug (straight); Spring clamp technology	756-9202/040-000	5
Configurable Connector; 4-pole; M12 plug (angled); Spring clamp technology	756-9205/040-000	5
Configurable Connector; 5-pole; M12 plug (straight); Screw connection technology	756-9201/050-000	5
Configurable Connector; 5-pole; M12 plug (angled); Screw connection technology	756-9204/050-000	5
Configurable Connector; 5-pole; M12 plug (straight); Spring clamp technology	756-9202/050-000	5
Configurable Connector; 5-pole; M12 plug (angled); Spring clamp technology	756-9205/050-000	5



Connectable cable:
 Ø 4 ... 6 mm/0.25 ... 0.75 mm² (Screw clamp technology)
 Ø 4 ... 6 mm/0.14 ... 0.50 mm² (Spring clamp technology)

4-pole
5-pole

M12 Socket, Straight and Angled		
	Item No.	PU
Configurable Connector; 4-pole; M12 socket (straight); Screw connection technology	756-9211/040-000	5
Configurable Connector; 4-pole; M12 socket (angled); Screw connection technology	756-9214/040-000	5
Configurable Connector; 4-pole; M12 socket (straight); Spring clamp technology	756-9212/040-000	5
Configurable Connector; 4-pole; M12 socket (angled); Spring clamp technology	756-9215/040-000	5
Configurable Connector; 5-pole; M12 socket (straight); Spring clamp technology	756-9212/050-000	5
Configurable Connector; 5-pole; M12 socket (angled); Spring clamp technology	756-9215/050-000	5

Configurable Shielded Connector; ETHERNET, PROFINET Accessories

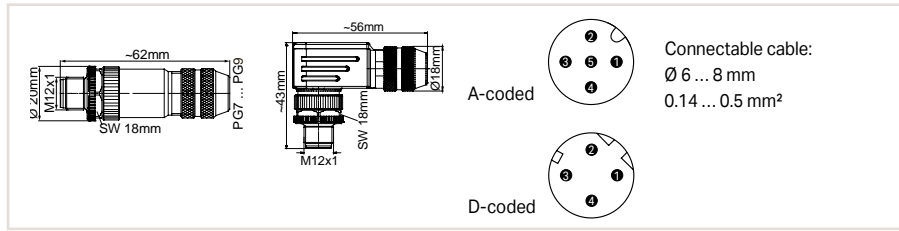

M12 Plug, Straight and Angled

	Item No.	PU
Configurable Connector; 5-pole; shielded; M12 plug (straight); A-coded; Spring clamp technology	756-9207/060-000	1
Configurable Connector; 4-pole; shielded; M12 plug (straight); D-coded; Spring clamp technology	756-9501/060-000	1
Configurable Connector; 5-pole; shielded; M12 plug (angled); A-coded; Spring clamp technology	756-9211/060-000	1
Configurable Connector; 4-pole; shielded; M12 plug (angled); D-coded; Spring clamp technology	756-9501/040-000	1

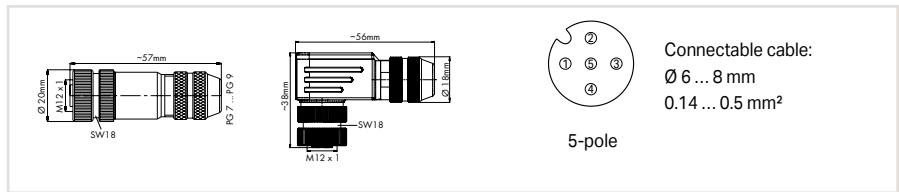

M12 Socket, Straight and Angled

	Item No.	PU
Configurable Connector; 5-pole; shielded; M12 socket (straight); Spring clamp technology	756-9208/060-000	1
Configurable Connector; 5-pole; shielded; M12 socket (angled); Spring clamp technology	756-9210/060-000	1

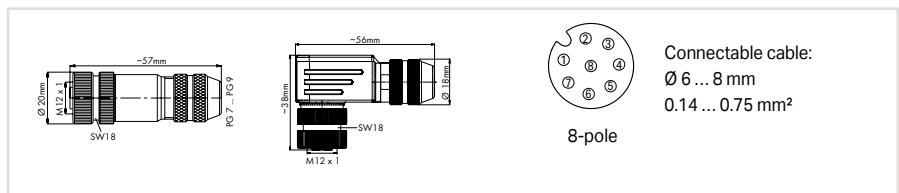

M12 Socket, Straight and Angled

	Item No.	PU
Configurable Connector; 8-pole; shielded; M12 socket (straight); Screw connection technology	756-9211/090-000	1
Configurable Connector; 8-pole; shielded; M12 socket (angled); Screw connection technology	756-9214/090-000	1

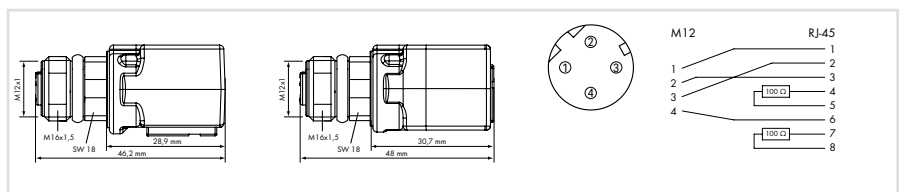

M12 Socket, Straight - RJ-45 Socket

	Item No.	PU
Socket; 4-pole, M12-socket (straight); D-coded; RJ-45 socket (angled)	756-9503/040-000	1
Socket; 4-pole, M12-socket (straight); D-coded; RJ-45 socket (straight)	756-9504/040-000	1

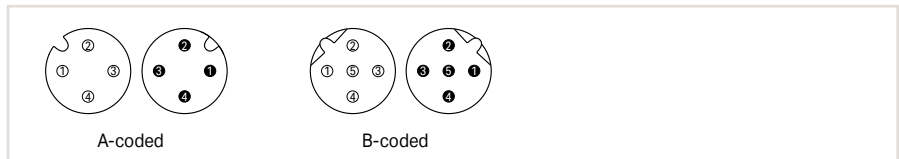

M12 Panel Feed-Through Connector

	Item No.	PU
M12 Panel Feed-Through Connector; 4-pole; M12 socket (straight); A-coded	756-9217/050-000	1
M12 Panel Feed-Through Connector; 5-pole; M12 socket (straight); B-coded	756-9406/050-000	1

Torque Wrench M8 and M12; Assembly Kit



Assembly kit for pre-assembled IP67 cables and hex nut connectors (756 Series) consists of:

- Tool kit
- Torque screwdriver with adjustable torque (window scale)
- Adjustment tool for changing the torque
- Socket wrench SW9 (for M8 cable assemblies)
- Socket wrench SW13 (for M12 cable assemblies)

A torque specification of 0.6 Nm for M8 connectors and 1.0 Nm for M12 connectors is required for both 756 Series Cables and Connectors.

Torque Wrench M8 and M12; Assembly Kit		
	Item No.	PU
	206-701	1

Torque range	0,4 ... 1 Nm \pm 6 %
Material	
Handle	Polypropylene (PP) for hard zone; thermoplastic elastomers (TPE) for soft zone
Allen key	Polyamide (PA), glass-fiber-reinforced; chrome-vanadium-molybdenum steel (CrMoV) (1.2381)
Adjustment tool	Cellulose acetate; chrome-vanadium-molybdenum steel (CrMoV) (1.2381)
Color	Black
Standards/specifications	EN ISO 6789; BS EN 26789; ASME B107.14.M

ETHERNET Cable; Cat. 6A S/FTP

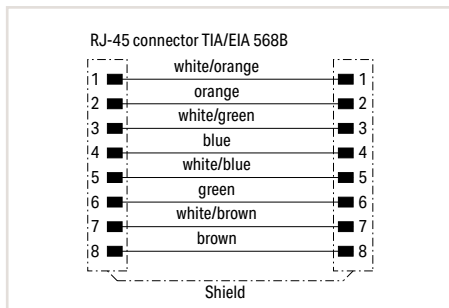

Item Description	ETHERNET Cable; Cat. 6A; RJ-45; RJ-45			ETHERNET Cable; Cat. 6A; RJ-45; RJ-45		
Version				Axial unlocking		
	Cable Length	Item No.	PU	Cable Length	Item No.	PU
	0.5 m	756-1250/1013-005	1	0.5 m	756-1250/1023-005	1
	1 m	756-1250/1013-010	1	1 m	756-1250/1023-010	1
	2 m	756-1250/1013-020	1	2 m	756-1250/1023-020	1
	3 m	756-1250/1013-030	1	3 m	756-1250/1023-030	1
	5 m	756-1250/1013-050	1	5 m	756-1250/1023-050	1
	7.5 m	756-1250/1013-075	1	7.5 m	756-1250/1023-075	1
	10 m	756-1250/1013-100	1	10 m	756-1250/1023-100	1

Technical Data

Transmission	10 Gbit/s (500 MHz)
Operating voltage	80 V
Operating current	720 mA
Rated surge voltage	500 V (wire/wire/shield rms 50 Hz 1 min)
Insulation resistance	≥ 1x108 Ωxkm
Resistance of conductor	< 142 Ω/km
Surrounding air temperature (operation)	-40 ... +80 °C (static and moving)
Bending radius	10 mm (min.)
Bending cycles	≥ 8500
Cable	S/FTP 4x2xAWG26/7
Overall shield	Overlapped aluminum-laminated foil and tinned copper braid (PiMF)
Conductor	Bare copper wire (7 x 0.16 mm)
Conductor insulation	Halogen-free PE
Outer jacket	LSOH TPE; halogen-free per IEC 60754-2; flame-retardant per IEC 60332-1; low-smoke per IEC 61034
Color	Green (RAL 6018)
Cable diameter	Ø 6.2 mm ±0.2
Plug	2 x Cat. 6A RJ-45
Contact material	CuZn
Contact plating	CuNi/Au; 50 µin gold plating
Mech. service life	> 1200 mating cycles
For data sheet and additional information, see:	wago.com/756-1250

Short description:

- Halogen-free TPE
- Cat. 6A S/FTP
- Highly flexible
- 50 µin gold plating in the contact area
- Mechanically/electrically tested
- 4C Channel Link Test
- Wrap-around label for clear traceability
- Easy plug unlocking (756-1250/1023-xxx)

Communication Cables and Antennas



Item Description	RS-232 Communication Cable; RS-232 (D-Sub; 9-pole); I/O System 750 Service Interface
Item No.	750-920
Order Text	Communication Cable
Technical Data	
Connectors	4-pole service connector
Cable length	2.5 m
Surrounding air temperature (operation)	0 ... +55 °C
Protection type	IP20
For data sheet and additional information, see:	wago.com/750-920

USB Communication Cable; USB-A; I/O System 750 Service Interface	
750-923	750-923/000-001
CONF-CABLE; USB; 2.5m	CONF-CABLE; USB; 5m
Technical Data	
USB interface: Type A/m; USB specification: 2.0 compatible/full-speed device	
2.5 m	5 m
-25 ... +70 °C	
IP20	
wago.com/750-923	

This communication cable connects the engineering software to the controller or fieldbus coupler.

This USB communication cable connects the engineering software to the controller or fieldbus coupler.

Notice: The communication cable must not be connected or removed when energized.

Notice: A specific firmware version is required to connect the 759-923 USB Communication Cable to some particular controllers.



Magnetic-Mount Antenna; with 2.5 m cable and SMA angled plug; GSM/UMTS/LTE/Bluetooth®/WLAN; 698-960, 1400-1518, 1710-2700 MHz	
Item No.	758-975
Technical Data	
Frequency band	698 ... 960 MHz; 1400 ... 1518 MHz; 1710 ... 2700 MHz
Connection cable length	2.5 m
Mounting type	Magnetic stand
Cable type	RG-174
Connector	SMA angled plug

RF Antenna; with 2.5 m cable and SMA plug; GSM/UMTS/LTE/Bluetooth®/WLAN; 698-960, 1710-6000 MHz; 2G/ 3G/ 4G/ 5G	
Item No.	758-974
Technical Data	
Frequency band	617 ... 960 MHz; 1710 ... 6000 MHz
Connection cable length	2.5 m
Mounting type	Enclosure installation; Adhesive strips
Cable type	CS29
Connector	SMA plug

RF Antenna; with 2.5 m cable and SMA plug; GSM/UMTS/LTE/Bluetooth®/WLAN; 698-960, 1710-6000 MHz; 2G/ 3G/ 4G/ 5G	
Item No.	758-974/000-001
Technical Data	
Frequency band	617 ... 960 MHz; 1710 ... 6000 MHz
Connection cable length	2.5 m
Mounting type	Wall-mount
Cable type	CS29
Connector	SMA plug

Memory Cards



Item Description	microSD Memory Card; Temperature range: -40 ... +90 °C	microSD Memory Card; Temperature range: -40 ... +90 °C
Version	SLC-NAND; 2 GB	pSLC-NAND; 8 GB
Item No.	758-879/000-3102	758-879/000-3108
Technical Data		
Memory	2 GB (SLC)	8 GB (pSLC)
Read/write cycles (max.)	20 MB/s / 17 MB/s	48 MB/s / 45 MB/s
MTBF	4,000,000 h	2,000,000 h
Service life	100,000 write cycles (per cell)	20,000 write cycles (per cell)
Data storage	10 years	10 years
Surrounding air temperature (operation)	-40 ... +90 °C	-40 ... +90 °C
Surrounding air temperature (storage)	-40 ... +90 °C	-40 ... +90 °C
Relative humidity	95 %; non condensing	95 %; non condensing
Dimensions W x H x D	15 x 11 x 1 mm	15 x 11 x 1 mm
Vibration resistance	15g	15g
Shock resistance	50g	50g



Item Description	SD Memory Card; Temperature range: -40 ... +90 °C	SD Memory Card; Temperature range: -40 ... +90 °C
Version	SLC-NAND; 2 GB	pSLC-NAND; 8 GB
Item No.	758-879/000-001	758-879/000-2108
Technical Data		
Memory	2 GB (SLC)	8 GB (pSLC)
Read/write cycles (max.)	22 MB/s / 16 MB/s	50 MB/s / 45 MB/s
MTBF	4,000,000 h	2,000,000 h
Service life	100,000 write cycles (per cell)	20,000 write cycles (per cell)
Data storage	10 years	10 years
Surrounding air temperature (operation)	-40 ... +90 °C	-40 ... +90 °C
Surrounding air temperature (storage)	-40 ... +90 °C	-40 ... +90 °C
Relative humidity	95 %; non condensing	95 %; non condensing
Dimensions W x H x D	24 x 32 x 2.1 mm	24 x 32 x 2.1 mm
Vibration resistance	15g	15g
Shock resistance	50g	50g

ETHERNET Connectors; Code T568A

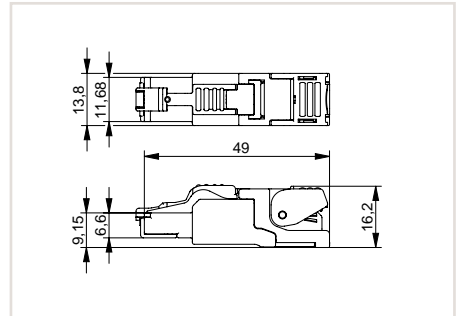
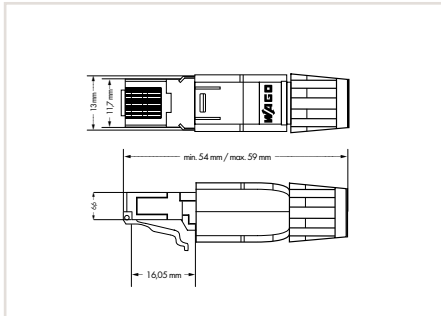
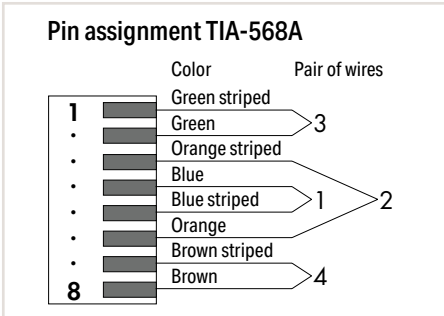

Item Description
Version
Item No.
Order Text

ETHERNET Connector; RJ-45; Cat. 5; Straight; Code T568A
AWG 22
750-975
Connector ETHERNET; RJ-45; Cat.5; 180°; T568A; AWG22

ETHERNET Connector; RJ-45; Cat. 6A; Straight; Code T568A	
AWG 22	AWG 24
750-977/000-011	750-977/000-021
Connector ETHERNET; RJ-45; Cat.6A; 180°; T568A; AWG22	Connector ETHERNET; RJ-45; Cat.6A; 180°; T568A; AWG24

Technical Data

Cable category
Data transmission rate (max.)
Code
Cable exit
Pole number
Housing material
Mating cycles
Conductor connection
Conductor cross-sections
Cable jacket diameter
Cable strain relief
Shield connection
Surrounding air temperature (operation)
Surrounding air temperature (storage)
Relative humidity
Protection type
Standards/specifications

Cat. 5e
1 GBit/s
TIA-568A
180°
8
Plastic
> 1000
IDC contact
Solid: 0.13 ... 0.24 mm ² / AWG 26/1 ... 23/1; Stranded: 0.14 ... 0.36 mm ² / AWG 26/7 ... 22/7
4.5 ... 8 mm
Screw clamp connection
> 180°
-20 ... +70 °C
-40 ... +70 °C
95 %; non condensing
IP20
Basic standard: IEC 60603-7 RJ-45 Category 5; CD ISO/IEC 11801: 2002; - EN 50173: 2002; EIA/TIA 568A: 2002; UL 1863

Cat. 6A	
10 GBit/s	
TIA-568A	
180°	
8	
Zinc die-cast	
> 750	
IDC contact	
Solid: 0.21 ... 0.32 mm ² / AWG 24/1 ... 22/1; Stranded: 0.11 ... 0.36 mm ² / AWG 27/7 ... 22/7	Solid: 0.13 ... 0.21 mm ² / AWG 26/1 ... 24/1; Stranded: 0.11 ... 0.23 mm ² / AWG 27/7 ... 24/7
5.5 ... 9 mm	
360°	
-40 ... +85 °C	
-40 ... +85 °C	
95 %; non condensing	
IP20	
IEC60603-7-51; ISO/IEC 11801; IEEE 802.3an; EIA/TIA 568-C.2; DIN EN 50173-1; UL 1863; UL 2043	

Approvals

For data sheet and additional information, see:

Marine
wago.com/750-975

wago.com/750-977/000-011	wago.com/750-977/000-021
--	--

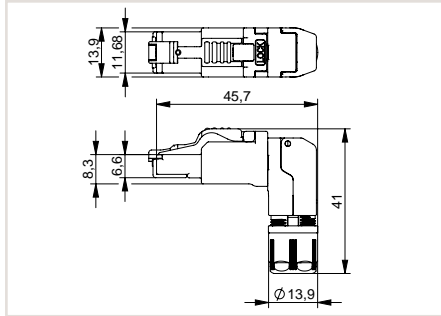
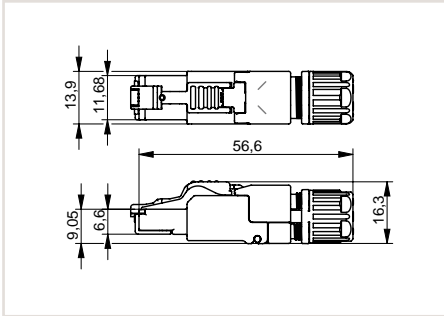

ETHERNET Connector; RJ-45; Cat. 6A; Straight; Code T568A; Strain relief	
AWG 22	AWG 24
750-978/000-011	750-978/000-021
Connector ETHERNET; RJ-45; Cat.6A; 180°; T568A; AWG22; Strain relief	Connector ETHERNET; RJ-45; Cat.6A; 180°; T568A; AWG24; Strain relief

ETHERNET Connector; RJ-45; Cat. 6A; Angled; Code T568A; Strain relief	
AWG 22	AWG 24
750-979/000-011	750-979/000-021
Connector ETHERNET; RJ-45; Cat.6A; 90°; T568A; AWG22; Strain relief	Connector ETHERNET; RJ-45; Cat.6A; 90°; T568A; AWG24; Strain relief

Cat. 6A	
10 GBit/s	
TiA-568A	
180°	
8	
Zinc die-cast	
> 750	
IDC contact	
Solid: 0.21 ... 0.32 mm ² / AWG 24/1 ... 22/1;	Solid: 0.13 ... 0.21 mm ² / AWG 26/1 ... 24/1;
Stranded: 0.11 ... 0.36 mm ² / AWG 27/7 ... 22/7	Stranded: 0.11 ... 0.23 mm ² / AWG 27/7 ... 24/7
5.5 ... 10 mm	5.5 ... 10 mm
Screw clamp connection	Screw clamp connection
360°	360°
-40 ... +85 °C	-40 ... +85 °C
-40 ... +85 °C	-40 ... +85 °C
95 %; non condensing	95 %; non condensing
IP20	IP20
IEC60603-7-51; ISO/IEC 11801; IEEE 802.3an; EIA/TIA 568-C.2; DIN EN 50173-1; UL 1863; UL 2043	IEC60603-7-51; ISO/IEC 11801; IEEE 802.3an; EIA/TIA 568-C.2; DIN EN 50173-1; UL 1863; UL 2043

Cat. 6A	
10 GBit/s	
TiA-568A	
90°; selectable position	
8	
Zinc die-cast	
> 750	
IDC contact	
Solid: 0.21 ... 0.32 mm ² / AWG 24/1 ... 22/1;	Solid: 0.13 ... 0.21 mm ² / AWG 26/1 ... 24/1;
Stranded: 0.11 ... 0.36 mm ² / AWG 27/7 ... 22/7	Stranded: 0.11 ... 0.23 mm ² / AWG 27/7 ... 24/7
5.5 ... 10 mm	5.5 ... 10 mm
Screw clamp connection	Screw clamp connection
360°	360°
-40 ... +85 °C	-40 ... +85 °C
-40 ... +85 °C	-40 ... +85 °C
95 %; non condensing	95 %; non condensing
IP20	IP20
IEC60603-7-51; ISO/IEC 11801; IEEE 802.3an; EIA/TIA 568-C.2; DIN EN 50173-1; UL 1863; UL 2043	IEC60603-7-51; ISO/IEC 11801; IEEE 802.3an; EIA/TIA 568-C.2; DIN EN 50173-1; UL 1863; UL 2043

wago.com/ 750-978/000-011	wago.com/ 750-978/000-021
---	---

wago.com/ 750-979/000-011	wago.com/ 750-979/000-021
---	---

ETHERNET Connectors; Code T568B

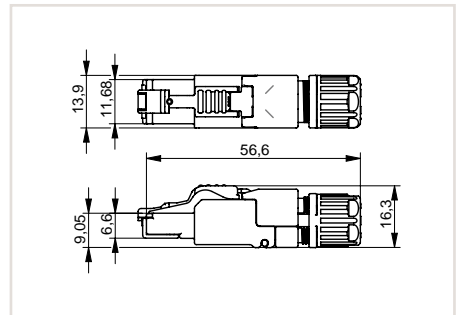
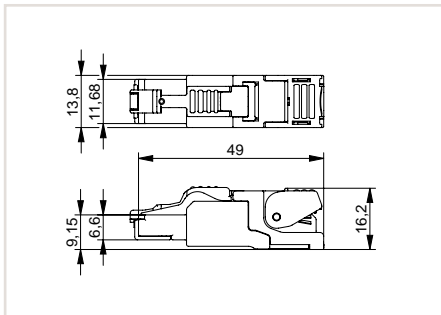
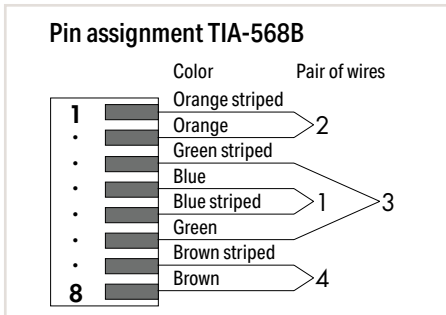

Item Description	
Version	
Item No.	
Order Text	

ETHERNET Connector; RJ-45; Cat. 6A; Straight; Code T568B	
AWG 22	AWG 24
750-977/000-012	750-977/000-022
Connector ETHERNET; RJ-45; Cat.6A; 180°; T568B; AWG22	Connector ETHERNET; RJ-45; Cat.6A; 180°; T568B; AWG24

ETHERNET Connector; RJ-45; Cat. 6A; Straight; Code T568B; Strain relief	
AWG 22	AWG 24
750-978/000-012	750-978/000-022
Connector ETHERNET; RJ-45; Cat.6A; 180°; T568B; AWG22; Strain relief	Connector ETHERNET; RJ-45; Cat.6A; 180°; T568B; AWG24; Strain relief

Technical Data					
Cable category	Cat. 6A				
Data transmission rate (max.)	10 GBit/s				
Code	TiA-568B				
Cable exit	180°				
Pole number	8				
Housing material	Zinc die-cast				
Mating cycles	> 750				
Conductor connection	IDC contact				
Conductor cross-sections	<table border="1"> <tr> <td>Solid: 0.21 ... 0.32 mm² / AWG 24/1 ... 22/1;</td> <td>Solid: 0.13 ... 0.21 mm² / AWG 26/1 ... 24/1;</td> </tr> <tr> <td>Stranded: 0.11 ... 0.36 mm² / AWG 27/7 ... 22/7</td> <td>Stranded: 0.11 ... 0.23 mm² / AWG 27/7 ... 24/7</td> </tr> </table>	Solid: 0.21 ... 0.32 mm ² / AWG 24/1 ... 22/1;	Solid: 0.13 ... 0.21 mm ² / AWG 26/1 ... 24/1;	Stranded: 0.11 ... 0.36 mm ² / AWG 27/7 ... 22/7	Stranded: 0.11 ... 0.23 mm ² / AWG 27/7 ... 24/7
Solid: 0.21 ... 0.32 mm ² / AWG 24/1 ... 22/1;	Solid: 0.13 ... 0.21 mm ² / AWG 26/1 ... 24/1;				
Stranded: 0.11 ... 0.36 mm ² / AWG 27/7 ... 22/7	Stranded: 0.11 ... 0.23 mm ² / AWG 27/7 ... 24/7				
Cable jacket diameter	5.5 ... 9 mm				
Cable strain relief					
Shield connection	360°				
Surrounding air temperature (operation)	-40 ... +85 °C				
Surrounding air temperature (storage)	-40 ... +85 °C				
Relative humidity	95 %; non condensing				
Protection type	IP20				
Standards/specifications	IEC60603-7-51; ISO/IEC 11801; IEEE 802.3an; EIA/TIA 568-C.2; DIN EN 50173-1; UL 1863; UL 2043				

Cable category	Cat. 6A				
Data transmission rate (max.)	10 GBit/s				
Code	TiA-568B				
Cable exit	180°				
Pole number	8				
Housing material	Zinc die-cast				
Mating cycles	> 750				
Conductor connection	IDC contact				
Conductor cross-sections	<table border="1"> <tr> <td>Solid: 0.21 ... 0.32 mm² / AWG 24/1 ... 22/1;</td> <td>Solid: 0.13 ... 0.21 mm² / AWG 26/1 ... 24/1;</td> </tr> <tr> <td>Stranded: 0.11 ... 0.36 mm² / AWG 27/7 ... 22/7</td> <td>Stranded: 0.11 ... 0.23 mm² / AWG 27/7 ... 24/7</td> </tr> </table>	Solid: 0.21 ... 0.32 mm ² / AWG 24/1 ... 22/1;	Solid: 0.13 ... 0.21 mm ² / AWG 26/1 ... 24/1;	Stranded: 0.11 ... 0.36 mm ² / AWG 27/7 ... 22/7	Stranded: 0.11 ... 0.23 mm ² / AWG 27/7 ... 24/7
Solid: 0.21 ... 0.32 mm ² / AWG 24/1 ... 22/1;	Solid: 0.13 ... 0.21 mm ² / AWG 26/1 ... 24/1;				
Stranded: 0.11 ... 0.36 mm ² / AWG 27/7 ... 22/7	Stranded: 0.11 ... 0.23 mm ² / AWG 27/7 ... 24/7				
Cable jacket diameter	5.5 ... 10 mm				
Cable strain relief	Screw clamp connection				
Shield connection	360°				
Surrounding air temperature (operation)	-40 ... +85 °C				
Surrounding air temperature (storage)	-40 ... +85 °C				
Relative humidity	95 %; non condensing				
Protection type	IP20				
Standards/specifications	IEC60603-7-51; ISO/IEC 11801; IEEE 802.3an; EIA/TIA 568-C.2; DIN EN 50173-1; UL 1863; UL 2043				

Cable category	Cat. 6A				
Data transmission rate (max.)	10 GBit/s				
Code	TiA-568B				
Cable exit	180°				
Pole number	8				
Housing material	Zinc die-cast				
Mating cycles	> 750				
Conductor connection	IDC contact				
Conductor cross-sections	<table border="1"> <tr> <td>Solid: 0.21 ... 0.32 mm² / AWG 24/1 ... 22/1;</td> <td>Solid: 0.13 ... 0.21 mm² / AWG 26/1 ... 24/1;</td> </tr> <tr> <td>Stranded: 0.11 ... 0.36 mm² / AWG 27/7 ... 22/7</td> <td>Stranded: 0.11 ... 0.23 mm² / AWG 27/7 ... 24/7</td> </tr> </table>	Solid: 0.21 ... 0.32 mm ² / AWG 24/1 ... 22/1;	Solid: 0.13 ... 0.21 mm ² / AWG 26/1 ... 24/1;	Stranded: 0.11 ... 0.36 mm ² / AWG 27/7 ... 22/7	Stranded: 0.11 ... 0.23 mm ² / AWG 27/7 ... 24/7
Solid: 0.21 ... 0.32 mm ² / AWG 24/1 ... 22/1;	Solid: 0.13 ... 0.21 mm ² / AWG 26/1 ... 24/1;				
Stranded: 0.11 ... 0.36 mm ² / AWG 27/7 ... 22/7	Stranded: 0.11 ... 0.23 mm ² / AWG 27/7 ... 24/7				
Cable jacket diameter	5.5 ... 10 mm				
Cable strain relief	Screw clamp connection				
Shield connection	360°				
Surrounding air temperature (operation)	-40 ... +85 °C				
Surrounding air temperature (storage)	-40 ... +85 °C				
Relative humidity	95 %; non condensing				
Protection type	IP20				
Standards/specifications	IEC60603-7-51; ISO/IEC 11801; IEEE 802.3an; EIA/TIA 568-C.2; DIN EN 50173-1; UL 1863; UL 2043				

Approvals	
For data sheet and additional information, see:	

wago.com/ 750-977/000-012	wago.com/ 750-977/000-022
---	---

wago.com/ 750-978/000-012	wago.com/ 750-978/000-022
---	---

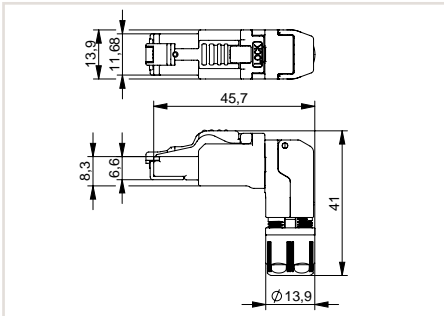

ETHERNET Connector; RJ-45; Cat. 6A; Angled; Code T568B; Strain relief

AWG 22	AWG 24
750-979/000-012	750-979/000-022
Connector ETHERNET; RJ-45; Cat.6A; 90°; T568B; AWG22; Strain relief	Connector ETHERNET; RJ-45; Cat.6A; 90°; T568B; AWG24; Strain relief

Cat. 6A				
10 GBit/s				
TiA-568B				
90°; selectable position				
8				
Zinc die-cast				
> 750				
IDC contact				
<table border="1"> <tbody> <tr> <td>Solid: 0.21 ... 0.32 mm² / AWG 24/1 ... 22/1;</td> <td>Solid: 0.13 ... 0.21 mm² / AWG 26/1 ... 24/1;</td> </tr> <tr> <td>Stranded: 0.11 ... 0.36 mm² / AWG 27/7 ... 22/7</td> <td>Stranded: 0.11 ... 0.23 mm² / AWG 27/7 ... 24/7</td> </tr> </tbody> </table>	Solid: 0.21 ... 0.32 mm ² / AWG 24/1 ... 22/1;	Solid: 0.13 ... 0.21 mm ² / AWG 26/1 ... 24/1;	Stranded: 0.11 ... 0.36 mm ² / AWG 27/7 ... 22/7	Stranded: 0.11 ... 0.23 mm ² / AWG 27/7 ... 24/7
Solid: 0.21 ... 0.32 mm ² / AWG 24/1 ... 22/1;	Solid: 0.13 ... 0.21 mm ² / AWG 26/1 ... 24/1;			
Stranded: 0.11 ... 0.36 mm ² / AWG 27/7 ... 22/7	Stranded: 0.11 ... 0.23 mm ² / AWG 27/7 ... 24/7			
5.5 ... 10 mm				
Screw clamp connection				
360°				
-40 ... +85 °C				
-40 ... +85 °C				
95 %; non condensing				
IP20				
IEC60603-7-51; ISO/IEC 11801; IEEE 802.3an; EIA/TIA 568-C.2; DIN EN 50173-1; UL 1863; UL 2043				
<table border="1"> <tbody> <tr> <td>wago.com/ 750-979/000-012</td> <td>wago.com/ 750-979/000-022</td> </tr> </tbody> </table>	wago.com/ 750-979/000-012	wago.com/ 750-979/000-022		
wago.com/ 750-979/000-012	wago.com/ 750-979/000-022			

PROFINET Connectors

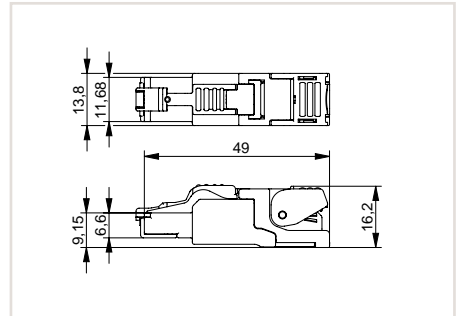
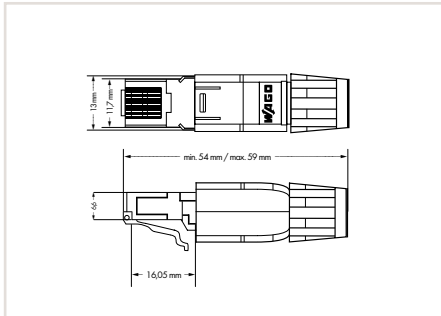
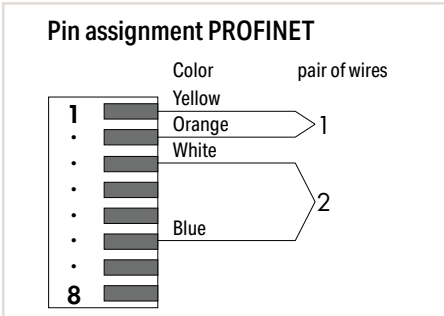

Item Description
Version
Item No.
Order Text

PROFINET Connector; RJ-45; Cat. 5; Straight
AWG 22
750-976
Connector PROFINET; RJ-45; Cat.5; 180°; AWG22

PROFINET Connector; RJ-45; Cat. 6A; Straight
AWG 22
750-977/000-013
Connector PROFINET; RJ-45; Cat.6A; 180°; AWG22

Technical Data	
Cable category	Cat. 5e
Data transmission rate (max.)	100 MBit/s
Code	PROFINET
Cable exit	180°
Pole number	8
Housing material	Plastic
Mating cycles	> 1000
Conductor connection	IDC contact
Conductor cross-sections	Solid: 0.13 ... 0.24 mm ² / AWG 26/1 ... 23/1; Stranded: 0.14 ... 0.36 mm ² / AWG 26/7 ... 22/7
Cable jacket diameter	4.5 ... 8 mm
Cable strain relief	Screw clamp connection
Shield connection	>180°
Surrounding air temperature (operation)	-20 ... +70 °C
Surrounding air temperature (storage)	-40 ... +70 °C
Relative humidity	95 %; non condensing
Protection type	IP20
Standards/specifications	Basic standard: IEC 60603-7 RJ-45 Category 5; CD ISO/IEC 11801: 2002; - EN 50173: 2002; EIA/TIA 568A: 2002; UL 1863
Approvals	Marine
For data sheet and additional information, see:	wago.com/750-976

Cat. 6A
100 MBit/s
PROFINET
180°
8
Zinc die-cast
> 750
IDC contact
Solid: 0.21 ... 0.32 mm ² / AWG 24/1 ... 22/1; Stranded: 0.11 ... 0.36 mm ² / AWG 27/7 ... 22/7
5.5 ... 9 mm
360°
-40 ... +85 °C
-40 ... +85 °C
95 %; non condensing
IP20
IEC60603-7-51; ISO/IEC 11801; IEEE 802.3an; EIA/TIA 568-C.2; DIN EN 50173-1; UL 1863; UL 2043
wago.com/750-977/000-013

Cat. 6A
100 MBit/s
PROFINET
180°
8
Zinc die-cast
> 750
IDC contact
Solid: 0.21 ... 0.32 mm ² / AWG 24/1 ... 22/1; Stranded: 0.11 ... 0.36 mm ² / AWG 27/7 ... 22/7
5.5 ... 9 mm
360°
-40 ... +85 °C
-40 ... +85 °C
95 %; non condensing
IP20
IEC60603-7-51; ISO/IEC 11801; IEEE 802.3an; EIA/TIA 568-C.2; DIN EN 50173-1; UL 1863; UL 2043
wago.com/750-977/000-013

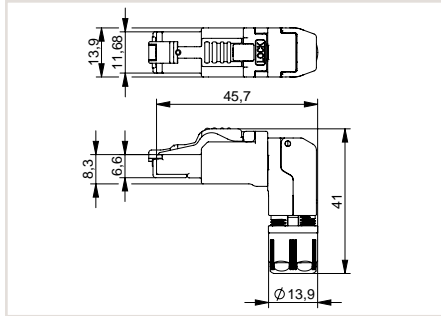
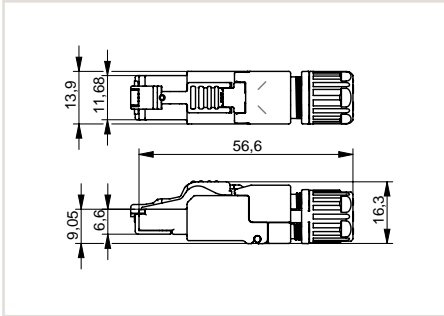

PROFINET Connector; RJ-45; Cat. 6A; Straight; Strain relief
AWG 22
 750-978/000-013
 Connector PROFINET; RJ-45; Cat.6A; 180°; AWG22; Strain relief

PROFINET Connector; RJ-45; Cat. 6A; Angled; Strain relief
AWG 22
 750-979/000-013
 Connector PROFINET; RJ-45; Cat.6A; 90°; AWG22; Strain relief

Cat. 6A
100 MBit/s
PROFINET
180°
8
Zinc die-cast
> 750
IDC contact
Solid: 0.21 ... 0.32 mm ² / AWG 24/1 ... 22/1; Stranded: 0.11 ... 0.36 mm ² / AWG 27/7 ... 22/7
5.5 ... 10 mm
Screw clamp connection
360°
-40 ... +85 °C
-40 ... +85 °C
95 %; non condensing
IP20
IEC60603-7-51; ISO/IEC 11801; IEEE 802.3an; EIA/TIA 568-C.2; DIN EN 50173-1; UL 1863; UL 2043
wago.com/750-978/000-013

Cat. 6A
100 MBit/s
PROFINET
90°; selectable position
8
Zinc die-cast
> 750
IDC contact
Solid: 0.21 ... 0.32 mm ² / AWG 24/1 ... 22/1; Stranded: 0.11 ... 0.36 mm ² / AWG 27/7 ... 22/7
5.5 ... 10 mm
Screw clamp connection
360°
-40 ... +85 °C
-40 ... +85 °C
95 %; non condensing
IP20
IEC60603-7-51; ISO/IEC 11801; IEEE 802.3an; EIA/TIA 568-C.2; DIN EN 50173-1; UL 1863; UL 2043
wago.com/750-979/000-013

PROFIBUS Fieldbus Connectors

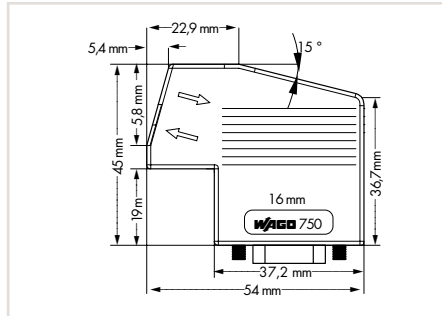
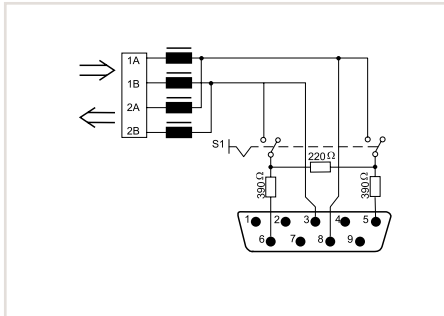

Item Description	PROFIBUS Fieldbus Connector; with D-sub plug; 9-pole
Item No.	750-960
Order Text	Connector PROFIBUS; DSub-M; 9P
Technical Data	
Double cable entry point	4.5 mm Ø (min.)/ 9.5 mm Ø (max.)
Data transmission rate (max.)	12 Mbit/s
Terminating resistor	Integrated switch
Housing color	Light gray
Protection type	IP20
Surrounding air temperature (operation)	0 ... +60 °C
Surrounding air temperature (storage)	-25 ... +85 °C
Relative humidity	95 %; non condensing
Conductor connection	CAGE CLAMP® terminal strip with locking slides (218 Series)
Conductor cross-sections	0.08 ... 0.5 mm ² / 28 ... 20 AWG; limited connection 0.75 mm ² / 18 AWG possible
Approvals	Marine; OrdLoc/HazLoc; ATEX/IECEx wago.com/750-960
For data sheet and additional information, see:	
Accessories	Item No.
Operating tool with a partially insulated shaft; Type 1; Blade (2.5 x 0.4) mm	210-719
Operating tool with a partially insulated shaft; Type 2; Blade (3.5 x 0.5) mm	210-720

PROFIBUS Fieldbus Connectors

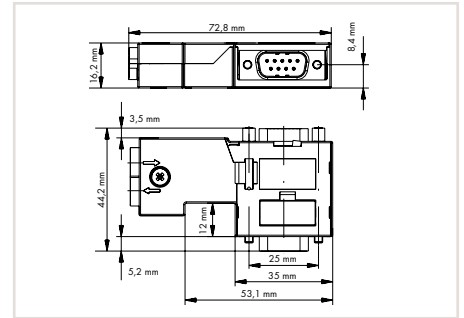
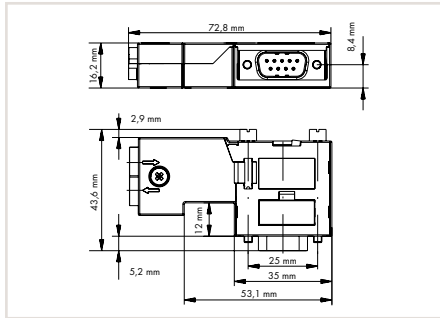
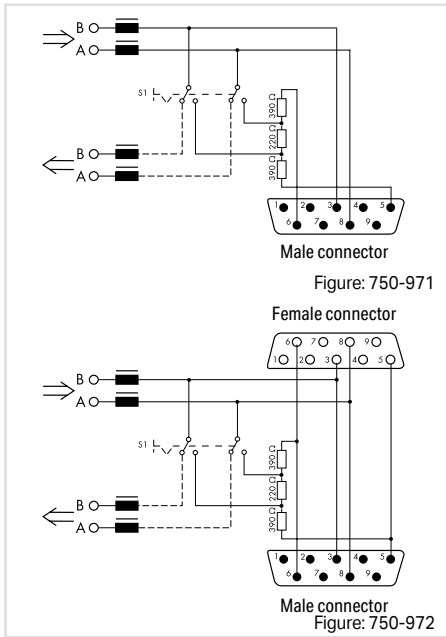

Item Description

Item No.

Order Text

Technical Data

Double cable entry point
Data transmission rate (max.)
Terminating resistor
Housing color
Protection type
Surrounding air temperature (operation)
Surrounding air temperature (storage)
Relative humidity
Conductor connection
Conductor cross-sections

For data sheet and additional information, see:

Accessories

Operating tool with a partially insulated shaft; Type 1; Blade (2.5 x 0.4) mm

PROFIBUS Fieldbus Connector; with D-sub plug; 9-pole

750-971

Connector PROFIBUS; DSub-M; 9P

Ø 8.5 mm
12 Mbit/s
Integrated switch
Light gray
IP20
-25 ... +70 °C
-25 ... +85 °C
95 %; non condensing
CAGE CLAMP® terminal strip with locking slides (218 Series)
0.08 ... 0.5 mm² / 28 ... 20 AWG; limited connection 0.75 mm² / 18 AWG possible
wago.com/750-971

Item No.

210-719

PROFIBUS Fieldbus Connector; with D-sub plug and socket; 9-pole

750-972

Connector PROFIBUS; DSub-M; 9P; PG-Int

Ø 8.5 mm
12 Mbit/s
Integrated switch
Light gray
IP20
-25 ... +70 °C
-25 ... +85 °C
95 %; non condensing
CAGE CLAMP® terminal strip with locking slides (218 Series)
0.08 ... 0.5 mm² / 28 ... 20 AWG; limited connection 0.75 mm² / 18 AWG possible
wago.com/750-972

Item No.

210-719

This fieldbus connector can be connected to a programming tool without interrupting the connection to the PROFIBUS device.

CANopen Fieldbus Connector

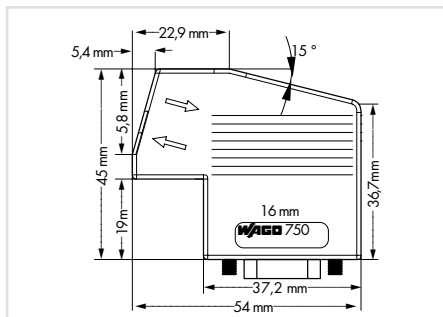
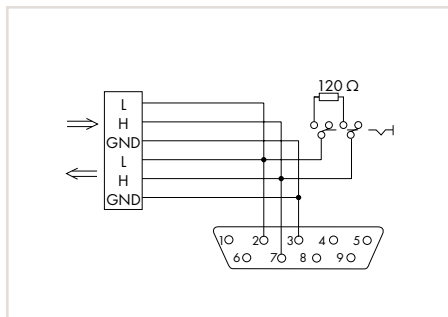

Item Description

Item No.

Order Text

Technical Data

Double cable entry point

Data transmission rate (max.)

Terminating resistor

Housing color

Protection type

Surrounding air temperature (operation)

Surrounding air temperature (storage)

Relative humidity

Conductor connection

Conductor cross-sections

Approvals

For data sheet and additional information, see:

Accessories

Operating tool with a partially insulated shaft; Type 1;
Blade (2.5 x 0.4) mm

Operating tool with a partially insulated shaft; Type 2;
Blade (3.5 x 0.5) mm

CANopen Fieldbus Connector; with D-sub socket;
9-pole

750-963

Connector CANopen; DSub-F; 9P

4.5 mm Ø (min.)/ 9.5 mm Ø (max.)

1 Mbd

Integrated switch

Light gray

IP20

0 ... +60 °C

-25 ... +85 °C

95 %; non condensing

CAGE CLAMP® terminal strip with locking slides
(218 Series)

0.08 ... 0.5 mm² / 28 ... 20 AWG; limited
connection 0.75 mm² / 18 AWG possible

☪ Marine; Ⓜ OrdLoc; Ⓜ ATEX/IECEx

wago.com/750-963

Item No.

210-719

210-720

INTERBUS Fieldbus Connectors

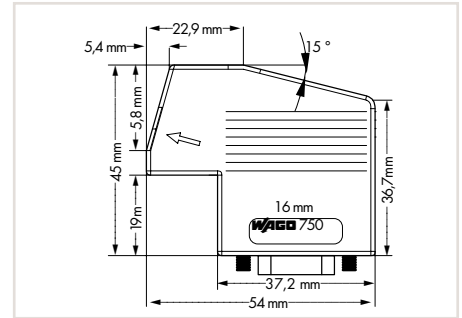
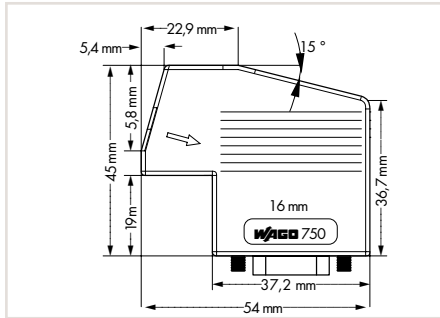
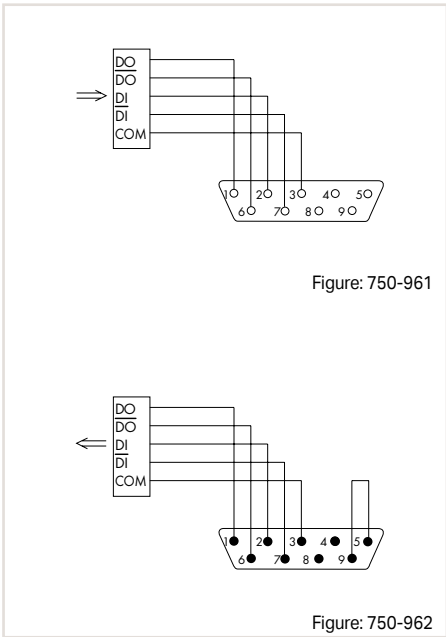

Item Description	
Item No.	750-961
Order Text	Connector INTERBUS; DSub-F; 9P
Technical Data	
Double cable entry point	4.5 mm Ø (min.)/ 9.5 mm Ø (max.)
Data transmission rate (max.)	2 Mbd
Housing color	Light gray
Protection type	IP20
Surrounding air temperature (operation)	0 ... +60 °C
Surrounding air temperature (storage)	-25 ... +85 °C
Relative humidity	95 %; non condensing
Conductor connection	CAGE CLAMP® terminal strip with locking slides (218 Series)
Conductor cross-sections	0.08 ... 0.5 mm² / 28 ... 20 AWG; limited connection 0.75 mm² / 18 AWG possible
Approvals	Ⓢ OrdLoc/HazLoc; Ⓢ ATEX/IECEX
For data sheet and additional information, see:	wago.com/750-961
Accessories	
Operating tool with a partially insulated shaft; Type 1; Blade (2.5 x 0.4) mm	210-719
Operating tool with a partially insulated shaft; Type 2; Blade (3.5 x 0.5) mm	210-720

INTERBUS Fieldbus Connector (IN); with D-sub socket; 9-pole	
Item No.	750-961
Order Text	Connector INTERBUS; DSub-F; 9P
Technical Data	
Double cable entry point	4.5 mm Ø (min.)/ 9.5 mm Ø (max.)
Data transmission rate (max.)	2 Mbd
Housing color	Light gray
Protection type	IP20
Surrounding air temperature (operation)	0 ... +60 °C
Surrounding air temperature (storage)	-25 ... +85 °C
Relative humidity	95 %; non condensing
Conductor connection	CAGE CLAMP® terminal strip with locking slides (218 Series)
Conductor cross-sections	0.08 ... 0.5 mm² / 28 ... 20 AWG; limited connection 0.75 mm² / 18 AWG possible
Approvals	Ⓢ OrdLoc/HazLoc; Ⓢ ATEX/IECEX
For data sheet and additional information, see:	wago.com/750-961
Accessories	
Operating tool with a partially insulated shaft; Type 1; Blade (2.5 x 0.4) mm	210-719
Operating tool with a partially insulated shaft; Type 2; Blade (3.5 x 0.5) mm	210-720

INTERBUS Fieldbus Connector (OUT); with D-sub plug; 9-pole	
Item No.	750-962
Order Text	Connector INTERBUS; DSub-M; 9P
Technical Data	
Double cable entry point	4.5 mm Ø (min.)/ 9.5 mm Ø (max.)
Data transmission rate (max.)	2 Mbd
Housing color	Light gray
Protection type	IP20
Surrounding air temperature (operation)	0 ... +60 °C
Surrounding air temperature (storage)	-25 ... +85 °C
Relative humidity	95 %; non condensing
Conductor connection	CAGE CLAMP® terminal strip with locking slides (218 Series)
Conductor cross-sections	0.08 ... 0.5 mm² / 28 ... 20 AWG; limited connection 0.75 mm² / 18 AWG possible
Approvals	Ⓢ OrdLoc/HazLoc; Ⓢ ATEX/IECEX
For data sheet and additional information, see:	wago.com/750-962
Accessories	
Operating tool with a partially insulated shaft; Type 1; Blade (2.5 x 0.4) mm	210-719
Operating tool with a partially insulated shaft; Type 2; Blade (3.5 x 0.5) mm	210-720

CC-Link Fieldbus Connector

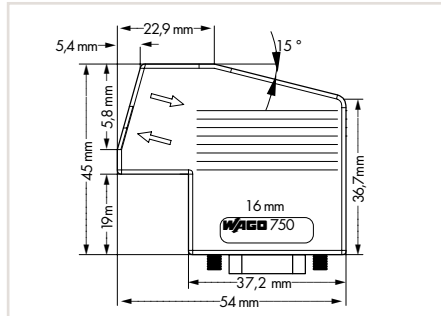
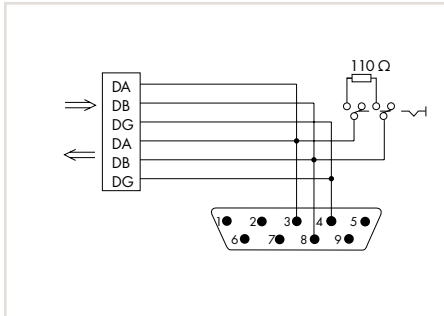

Item Description	CC-Link Fieldbus Connector; with D-sub plug; 9-pole
Item No.	750-965
Order Text	Connector CC-Link; DSub-M; 9P
Technical Data	
Double cable entry point	4.5 mm Ø (min.)/ 9.5 mm Ø (max.)
Terminating resistor	Integrated switch
Housing color	Light gray
Protection type	IP20
Surrounding air temperature (operation)	0 ... +60 °C
Surrounding air temperature (storage)	-25 ... +85 °C
Relative humidity	95 %; non condensing
Conductor connection	CAGE CLAMP® terminal strip with locking slides (218 Series)
Conductor cross-sections	0.08 ... 0.5 mm ² / 28 ... 20 AWG; limited connection 0.75 mm ² / 18 AWG possible
Approvals	® OrdLoc
For data sheet and additional information, see:	wago.com/750-965
Accessories	
Operating tool with a partially insulated shaft; Type 1; Blade (2.5 x 0.4) mm	210-719
Operating tool with a partially insulated shaft; Type 2; Blade (3.5 x 0.5) mm	210-720

System Enclosures



- 1 Sheet steel
- 2 Cast aluminum
- 3 Polyester
- 4 Sheet steel with cable entry plates

The increasing importance of using the application industrial fieldbus systems in various process engineering areas, such as the chemical and food industry, calls for enclosures that protect both the system technology used and the goods being produced.

This is why WAGO offers system enclosures that allow the use of the WAGO I/O System 750/753 in systems exposed to severe environmental conditions. Each enclosure version is available in four different sizes and features the appropriate number of cable grips with metric thread or cable entry plates.

Sheet-Steel System Enclosures

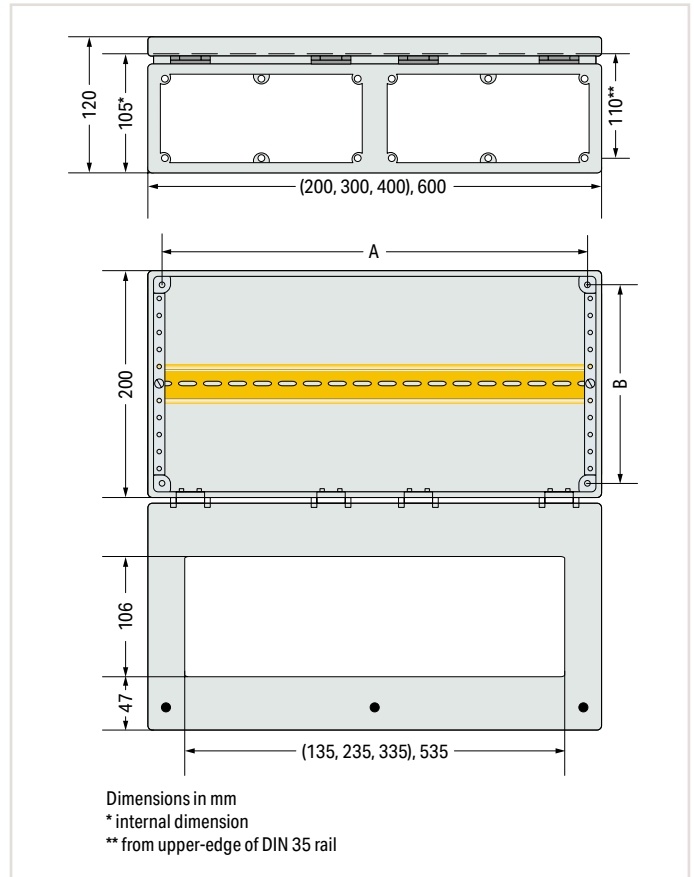

Item Description	IP65 System Enclosure; Sheet steel (RAL 7035); without flange plate			
Version	WxHxD (200x120x200 mm)	WxHxD (300x120x200 mm)	WxHxD (400x120x200 mm)	WxHxD (600x120x200 mm)
Item No.	850-814/002-000	850-815/002-000	850-816/002-000	850-817/002-000
Order Text	STE Enclosure; RAL7035 200mm	STE Enclosure; RAL7035 300mm	STE Enclosure; RAL7035 400mm	STE Enclosure; RAL7035 600mm

Technical Data				
Recommended assembly dimension (A x B)	160 x 160	260 x 160	360 x 160	560 x 160
Dimensions W x H x D	200 x 120 x 200 mm	300 x 120 x 200 mm	400 x 120 x 200 mm	600 x 120 x 200 mm
Number of I/O modules	≤ 8*	≤ 16*	≤ 24*	≤ 40*
For data sheet and additional information, see:	wago.com/ 850-814/002-000	wago.com/ 850-815/002-000	wago.com/ 850-816/002-000	wago.com/ 850-817/002-000

Accessories: Flange Plates	Number of flange plates that can be fitted			
Size 195 x 95 mm: F200; F200-1; F200-2; F204	1	-	2	-
Size 295 x 95 mm: F300; F300-1; F300-2; F304	-	1	-	2

Accessories	Item No.
Wall Mount	850-904

*Both fieldbus coupler and end module are part of the system. This applies to 12 mm wide I/O modules. I/O modules with a width of 24 mm count as two I/O modules.

Included:

- Powder-coated, sheet steel enclosure
- Box with narrow beveled edge, sturdy gutter profile
- Hinged cover 180° (PA), with foam PU seal and 2-3 quick disconnects
- Quick-release fasteners in plastic bushes
- Mounting holes (incl. sealing plugs)
- Large Makrolon inspection glass
- Removable, yellow-tinted chrome interior profiles
- Galvanized DIN-35/7.5 rail (contact with enclosure), adjustable in 12.5 mm spacing
- Grounding lug for cover and flanges with quick-release ribbon cable connectors
- Light gray (RAL 7035)

Flange Plates and Cable Entry Plates

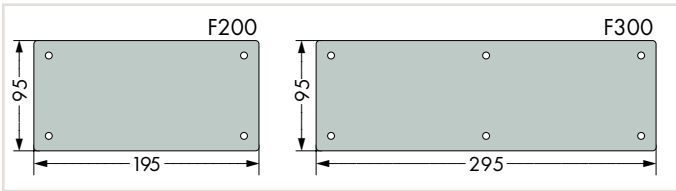

Flange Plate; RAL7035; without cut-out		
	Width x Height	Item No.
F200 Flange Plate RAL7035 WCO	195 x 95 mm	850-818/002-000
F300 Flange Plate RAL7035 WCO	295 x 95 mm	850-819/002-000

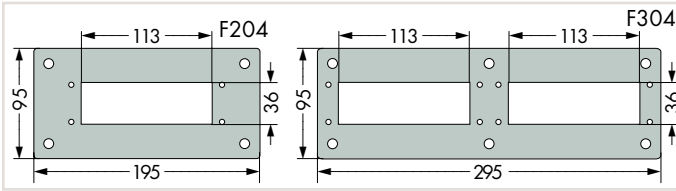

Flange Plate; RAL7035; with cut-out		
	Width x Height	Item No.
F204 Flange Plate RAL7035 1CO	195 x 95 mm	850-818/002-005
F304 Flange Plate RAL7035 2CO	295 x 95 mm	850-819/002-005



Illustration: Flange Plate F204 with Cable Entry Plate KDP 22

Cable Entry Plate		Item No.
KDP 22 Cable Entry Plate; 16 x Size 1, 4 x Size 2, 2 x Size 3		850-820/000-001
KDP 29 Cable Entry Plate; 29 x Size 1		850-820/000-002

Cable entry plate, polyamide
 Size 1: Cable diameter 3.0 ... 6.5 mm
 Size 2: Cable diameter 5.0 ... 9.2 mm
 Size 3: Cable diameter 8.0 ... 12.5 mm

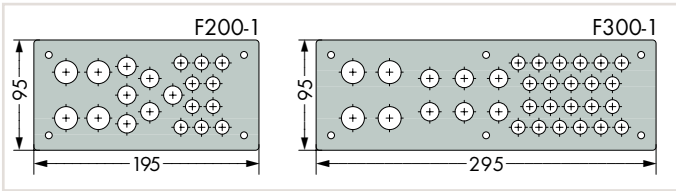

Flange Plate; RAL7035; M20, M16, M12 bore holes		
	Width x Height	Item No.
F200-1 Flange Plate RAL7035 HO1; 4 x M20, 6 x M16, 10 x M12	195 x 95 mm	850-818/002-001
F300-1 Flange Plate RAL7035 HO5; 4 x M20, 6 x M16, 22 x M12	295 x 95 mm	850-819/002-001



Flange Plate; RAL7035; M20, M16, M12 cable grips		
	Width x Height	Item No.
F200-1 Flange Plate RAL7035 CG8; 4 x M20, 6 x M16, 10 x M12	195 x 95 mm	850-818/002-002
F300-1 Flange Plate RAL7035 CG9; 4 x M20, 6 x M16, 22 x M12	295 x 95 mm	850-819/002-002

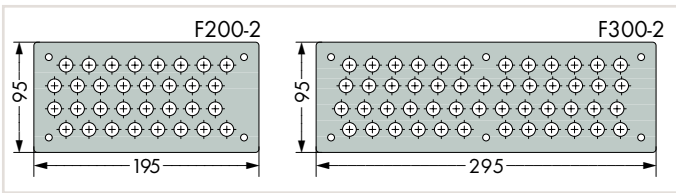

Flange Plate; RAL7035; M12 bore holes		
	Width x Height	Item No.
F200-2 Flange Plate RAL7035 HO4; 32 x M12	195 x 95 mm	850-818/002-003
F300-2 Flange Plate RAL7035 HO6; 50 x M12	295 x 95 mm	850-819/002-003



Similar to illustration

Flange Plate; RAL7035; M12 cable grips		
	Width x Height	Item No.
F200-2 Flange Plate RAL7035 HO2; 32 x M12	195 x 95 mm	850-818/002-004
F300-2 Flange Plate RAL7035 CG12; 50 x M12	295 x 95 mm	850-819/002-004

Aluminum System Enclosures

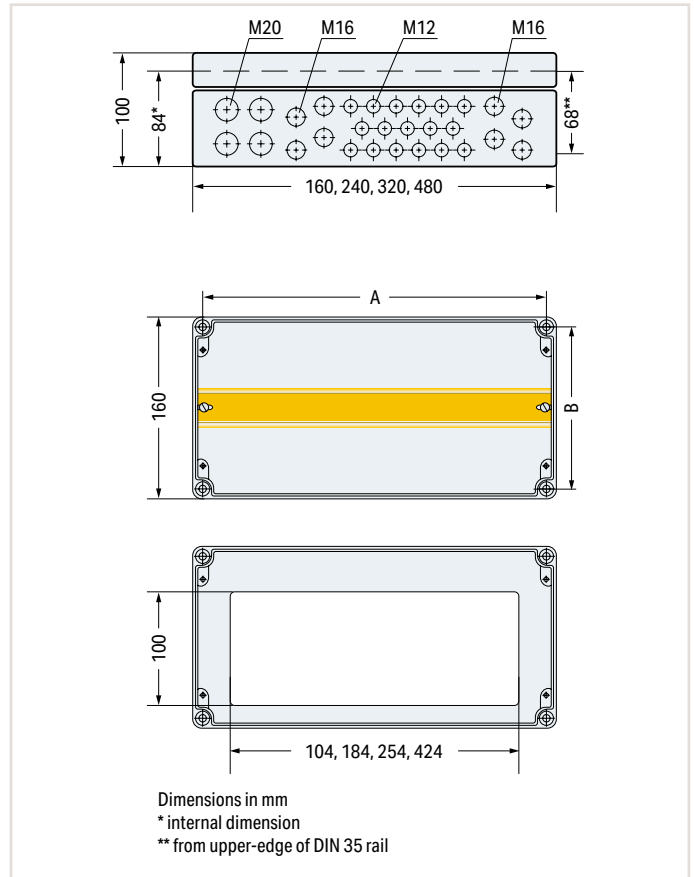

Item Description	IP65 System Enclosure; Aluminum			
Version	Enclosure type in RAL 7032			
Item No.	850-825	850-826	850-827	850-828
Order Text	ALU Enclosure; RAL7032 160mm CG11	ALU Enclosure; RAL7032 240mm CG7	ALU Enclosure; RAL7032 320mm CG10	ALU Enclosure; RAL7032 480mm CG4

Version	Enclosure type in RAL 7035			
Item No.		850-826/002-000	850-827/002-000	850-828/002-000
Order Text		ALU Enclosure; RAL7035 240mm CG7	ALU Enclosure; RAL7035 320mm CG10	ALU Enclosure; RAL7035 480mm CG4

Technical Data				
Number of M12 cable grips	9	14	17	35
Number of M16 cable grips	-	4	8	10
Number of M20 cable grips	4			
Recommended assembly dimension (A x B)	142 x 142 mm	222 x 142 mm	302 x 142 mm	462 x 142 mm
Dimensions W x H x D	160 x 100 x 160 mm	240 x 100 x 160 mm	320 x 100 x 160 mm	480 x 100 x 160 mm
Number of I/O modules	≤ 4*	≤ 11*	≤ 18*	≤ 31*
For data sheet and additional information, see:	wago.com/850-825	wago.com/850-826	wago.com/850-827	wago.com/850-828

Accessories	Item No.
Pole Mount	850-903

*Both fieldbus coupler and end module are part of the system. This applies to 12 mm wide I/O modules. I/O modules with a width of 24 mm count as two I/O modules.

Included:

- Aluminum enclosure, G AL Si 12 alloy / DIN 1725
- Stainless steel cover screws, captive
- Inspection glass, incl. attachment panel for customer marking (marking not included in scope of supply)
- Mounting holes (4 mounting channels located outside the sealed enclosure)
- Metric cable glands (brass, nickel-plated), incl. blind plugs
- M12 cable grip, cable diameter 3 ... 6 mm
- M16 cable grip, cable diameter 5 ... 9 mm
- M20 cable grip, cable diameter 9 ... 13 mm
- 1x DIN-35/7.5 rail
- Tongue and groove system, seal with groove in enclosure cover
- Oil and petroleum-resistant neoprene round cord seal
- Grounding link in enclosure
- Pebble gray RAL 7032 or light gray RAL 7035

Polyester System Enclosures

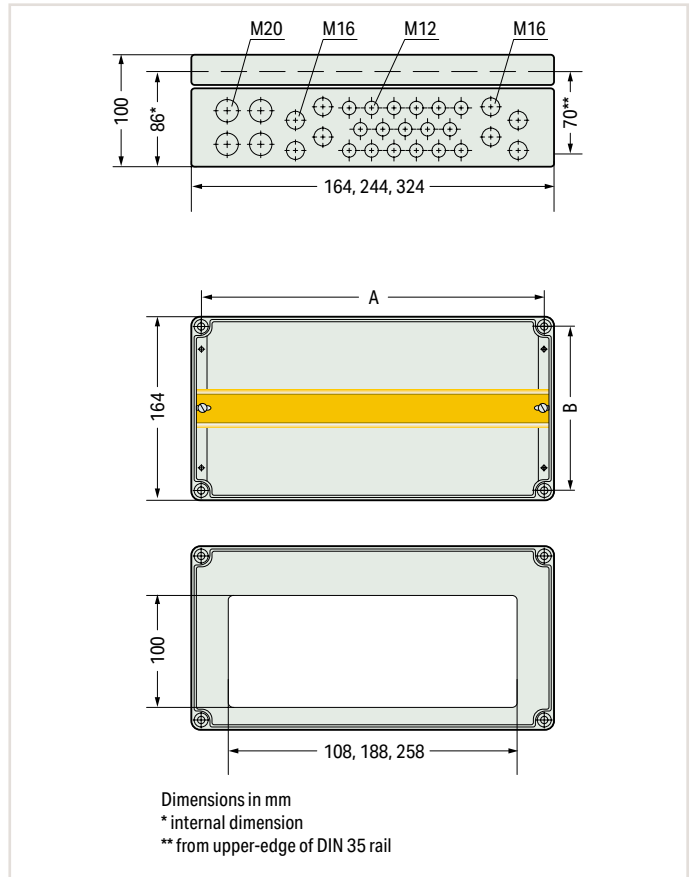

Item Description	IP65 System Enclosure; Polyester (RAL 7032)		
Version	WxHxD (164x100x164 mm); 9 x M12, 4 x M20	WxHxD (244x100x164 mm); 4 x M20, 4 x M16, 14 x M12 cable grip	WxHxD (324x100x164 mm); 4 x M20, 8 x M16, 17 x M12 cable grip
Item No.	850-834	850-835	850-836
Order Text	POL Enclosure; RAL7032 164mm CG11	POL Enclosure; RAL7032 244mm CG7	POL Enclosure; RAL7032 324mm CG10

Technical Data			
Number of M12 cable grips	9	14	17
Number of M16 cable grips	-	4	8
Number of M20 cable grips		4	
Recommended assembly dimension (A x B)	142 x 142 mm	222 x 142 mm	302 x 142 mm
Dimensions W x H x D	164 x 100 x 164 mm	244 x 100 x 164 mm	324 x 100 x 164 mm
Number of I/O modules	≤ 4*	≤ 11*	≤ 18*
For data sheet and additional information, see:	wago.com/850-834	wago.com/850-835	wago.com/850-836

Accessories	Item No.
Pole Mount	850-903

*Both fieldbus coupler and end module are part of the system. This applies to 12 mm wide I/O modules. I/O modules with a width of 24 mm count as two I/O modules.

Included:

- Polyester enclosure, glass-fiber-reinforced, halogen-free, as V0 version (self-extinguishing)
- Polyamide cover screws, captive
- Inspection glass, incl. attachment panel for customer marking (marking not included in scope of supply)
- Mounting holes (4 mounting channels located outside the sealed enclosure)
- Metric cable grips (polyamide PA 6), incl. blind plugs
- M12 cable grip, cable diameter 3 ... 6 mm
- M16 cable grip, cable diameter 5 ... 9 mm
- M20 cable grip, cable diameter 9 ... 13 mm
- 1x DIN-35/7.5 rail
- Oil and petroleum-resistant neoprene round cord seal
- Pebble gray, RAL 7032

DALI Multi-Sensors

Ceiling Installation

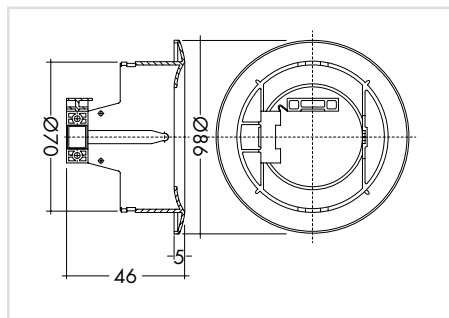

Wall Box Mounting

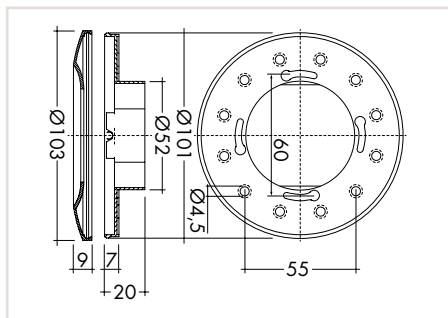

Surface Mounting

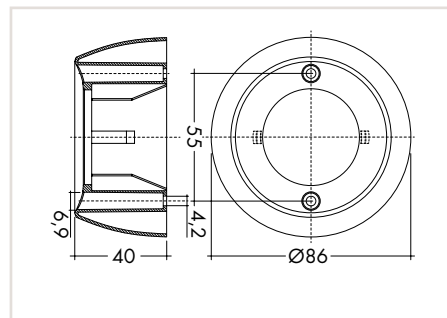

The WAGO DALI MSensor 02 is paired with DALI Master I/O modules (753-647 or 750-641) and has been designed for the following key applications:

- Individual offices
- Open-plan offices
- Training/presentation rooms
- Corridors, passageways and garages

WAGO's Multi-Sensor features both a motion/presence detector and a light sensor. It may also be operated with an optional remote control from Tridonic. The sensor enables both motion/presence detection and daylight-dependent lighting control, both of which can also be deactivated.

Addressing is performed via rotary switch or WAGO DALI Configurator. Parameters can be adjusted individually using the configurator.

Power supply is provided via the DALI line.

The number of sensors, which can be operated on a DALI line, depends on the total power consumption of the specific devices and the address range for the actuators and sensors. Due to the capacity of the DALI bus, a maximum of 16 DALI sensor couplers may be operated on a DALI Multi-Master Module (753-647).

Installation notes:

- The DALI MSensor 02 is supplied directly via DALI line.
- DALI is not SELV (Safety Extra Low Voltage). The installation instructions for mains voltage therefore apply.
- The sensor's detection range must be within the lighting area of the controlled luminaires.
- The sensors' detection ranges must not overlap as this may impair the lighting control.
- When installed at a height other than the recommended installation height (2.5 m), the presence and light sensor might show different characteristics. If installed at a greater height, the sensitivity is reduced; the range is also reduced when installed at a lower height.
- Heaters, fans, printers and copiers located in the detection range may cause incorrect presence detection.

Item Description	DALI MSensor 02 5DPI 41rc (Recessed Ceiling Installation)	DALI MSensor 02 5DPI 41w (Wall Box Mounting)	DALI MSensor 02 5DPI 41rs (Surface Mounting)
Item No.	2851-8301	2851-8302	2851-8303
Technical Data			
Diameter of detection range when installed at a height of 2.5 m	5 m		
Extension of the detection range	2 m (if mounted at a height of 2.5 m and swiveled through 15°)	-	
Swivel design	Yes	No	
Swivel range	± 15°	-	
Detection angle	360°		
Light measurement at the sensor head	10 ... 650 lx (The measured value at the sensor head corresponds to approx. 15 to 2,000 lux on the surface measured.)		
Remote control range	5 m		
For data sheet and additional information, see:	wago.com/2851-8301	wago.com/2851-8302	wago.com/2851-8303

Technical Data	
Power supply	Via DALI line
Power consumption	6 mA from DALI line
Surrounding air temperature (operation)	0 ... +50 °C
Surrounding air temperature (storage)	-25 ... +55 °C
Protection type	IP20
Wire type and cross-section	Solid or fine-stranded wires ranging from 0.5 to 1.5 mm ² (20 ... 16 AWG)

Technical Data	
General Settings	
Motion detector	Switching, on/off
Lighting control	Switching
Setpoint (lighting control)	150 lx
Power-on setting	No action
Bright-out timeout	10 min
Bright-out threshold	150 %
Control speed	4
Switch-on value	Automatic (calculated)
Rotary switch	0, broadcast
Motion Detector Settings	
Fade-in time	< 0.7 s
Presence value	Regulated
Run-on time	20 min
Fade time	5.6 s
Absence value	3 %
Switch-off delay	10 min
Fade-off time	5.6 s
Manual-off	10 min

Light Detection

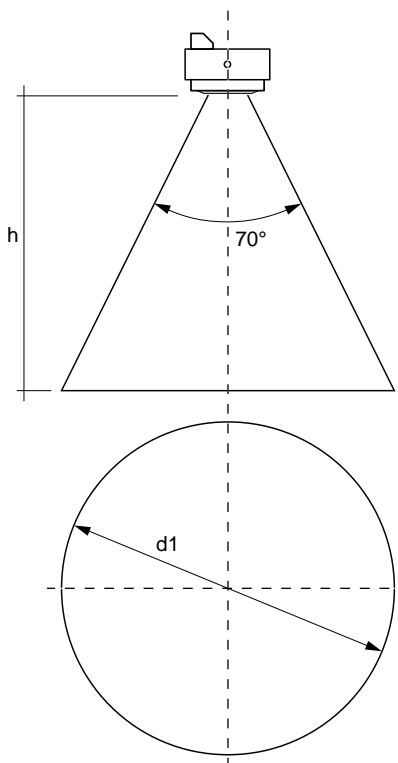

h^*	$d1$	$d2$	$d3$
1,7 m	2,4 m	3,4 m	1,36 m
2,0 m	2,8 m	4,0 m	1,60 m
2,3 m	3,2 m	4,6 m	1,84 m
2,5 m	3,5 m	5,0 m	2,00 m
2,7 m	3,8 m	5,4 m	-
3,0 m	4,2 m	6,0 m	-
3,5 m	4,9 m	7,0 m	-
4,0 m	5,6 m	8,0 m	-

Motion Detection (d2) and Presence Detection (d3)

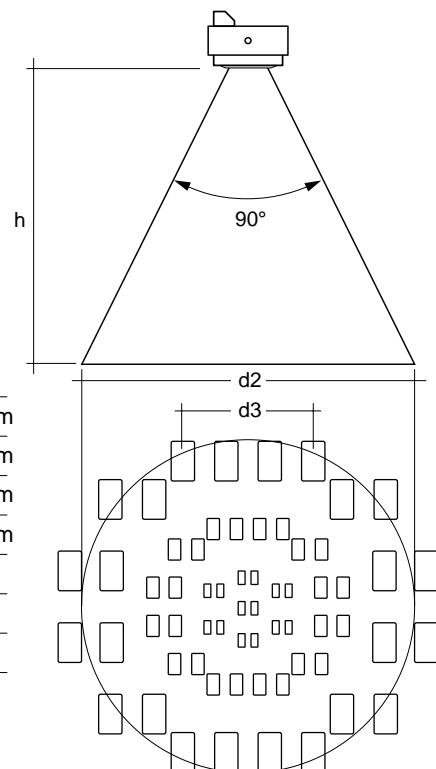

*The recommended maximum room height for office applications is 3 m and for corridor applications 4 m, for example.

Calculation of the diameter:
 $d = 2 \times \tan(0.5 \times \alpha) \times h$

WAGO DALI Multi-Sensor Kit

DALI Sensor Coupler



MULTI-3-CI Sensor



Eco-CI Kit

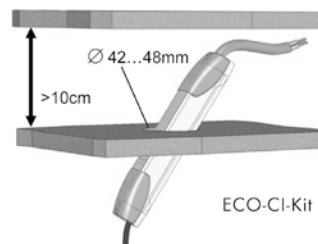

The WAGO DALI Multi-Sensor Kit is paired with the WAGO 753-647 DALI Multi-Master Module and includes the following three components:

- DALI Sensor Coupler (also available individually)
- Eco-CI Kit
- MULTI-3-CI Sensor

The DALI Sensor Coupler connects the MULTI-3-CI Sensor to a DALI bus system. For this, the MULTI-3-CI Sensor is connected to the DALI Sensor Coupler via RJ-10 socket. DALI terminals connect the DALI Sensor Coupler to both the DALI network and WAGO DALI Module.

The Eco-CI Kit contains two covers, which can be used as touch guards and strain relief for cables within the ceiling installation of the DALI Sensor Coupler.

The MULTI-3-CI Sensor has a motion and light sensor, enabling both motion detection and daylight-dependent lighting control. Power supply to the DALI Sensor Coupler is provided via DALI line. The DALI Sensor Coupler transmits measured values from the connected sensor channels as telegrams to the WAGO DALI Module via DALI line. Parameters can be adjusted individually via WAGO DALI Configurator.

The number of sensors, which can be operated on a DALI line, depends on the total power consumption of the specific devices and the address range for the actuators and sensors. Due to the capacity of the DALI bus, a maximum of 16 DALI Sensor Couplers may be operated on a DALI Multi-Master Module (753-647).

Installation

Sensor Connection

The MULTI-3-CI Sensor is connected to a 4-pole RJ-10 socket (4P4C), which is marked as "Sensor" on the housing cover.

For easy connection, the sensor plug is equipped with a quick-connect latch. Only one MULTI-3-CI Sensor must be connected to sensor coupler.

Ceiling Installation

For installation outside of a lighting fixture (e.g., suspended ceiling), the Eco-CI Kit must also be attached to both sides of the unit to ensure strain relief and touch protection.

The DALI Sensor Coupler can also be installed in lighting fixtures. The installation spaces available in lighting fixtures can be used, as the dimensions correspond to those of an electronic ballast.

Note:

The DALI Sensor Coupler is also available individually, allowing the unit to be combined with other multi-sensor models from OSRAM.

WAGO DALI Multi-Sensor Kit

Delivery type	Item No.
Set includes: DALI Sensor Coupler, MULTI-3-CI Sensor, Eco-CI Kit	2851-8201
DALI Sensor Coupler	2851-8202

DALI Sensor Coupler

Power supply	Via DALI line
Power consumption	5 mA (from the DALI line)
Input signal voltage/current	According to MULTI 3 CI Sensor
Conductor connection	Inputs: for MULTI-3-CI Sensor's modular plug 4p4c (RJ-10); Sensor cable length (max.): 5 m; DALI connection: Push-wire connectors; Strip length: 8.5 ... 9.5 mm
Conductor cross-sections	0.5 ... 1.5 mm ² (s + f-st)
Dimensions W x H x D	118 x 21 x 30 mm
Weight	35 g
Surrounding air temperature (operation)	0 ... +50 °C
Surrounding air temperature (storage)	-25 ... +70 °C
Relative humidity	5 ... 93 %; non-condensing
Protection type	IP20
Approvals	CE

Eco-CI Kit

Installation opening diameter	42 ... 48 mm
Minimum suspended ceiling clearance	25 mm

MULTI-3-CI Sensor

Maximum total length of signal line (incl. all connections to the control units)	100 m
Dimensions (diameter x H)	50 x 25 mm
Light sensor detection range	20 ... 600 lx (measured at sensor), beam angle approx. 90°
Recommended installation height	2 ... 4 m
Motion detection range	Cone-shaped, beam angle approx. 80°, depending on installation level 4 ... 8 m

Power supply; Compact; 1-phase; 18 VDC / 1.25 A 787 Series

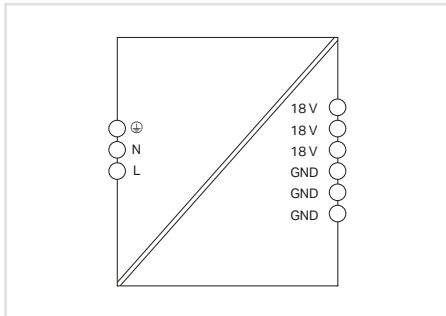

Power supply; Compact; 1-phase; 18 VDC output voltage; 1.25 A output current

	Item No.	PU
	787-2857	1

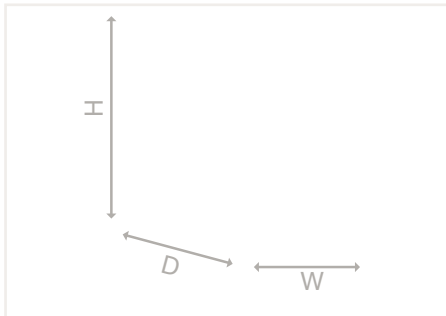

Features:

- Stepped profile for installation in standard distribution boards
- Connection technology with Push-in CAGE CLAMP®
- Parallel operation/series operation
- Electrically isolated output voltage (SELV) per EN/UL 61010-1 or EN/UL 61010-2-201

Input	
Nominal input voltage $U_{i, \text{nom}}$	1 x 100 ... 240 VAC
Input voltage range	100 ... 264 VAC
Nominal mains frequency range	47 ... 63 Hz
Input current I_i	≤ 0.4 A (110 VAC); ≤ 0.2 A (240 VAC)
Inrush current	≤ 24 A (NTC)
Mains failure hold-up time	≥ 95 ms (230 VAC)
Output	
Nominal output voltage $U_{o, \text{nom}}$ /Control deviation	18 VDC (SELV) / ≤ 2 %
Nominal output current $I_{o, \text{nom}}$	1.25 A (18 VDC)
Nominal output power	22 W
Residual ripple	≤ 60 mV (peak-to-peak)
Overload behavior	Hiccup
Signaling and communication	
Signaling	1 x Status indication LED (green)
Operation status indicator	Green LED (U_o)
Efficiency/power losses	
Power loss P_i	≤ 0.5 W (230 VAC; No load); ≤ 4 W (230 VAC; Nominal load)
Power loss (max.) $P_{i(\text{max})}$	5 W (110 VAC / 24 VDC; 1,35 A)
Efficiency (typ.)	88 %
Circuit protection	
Internal fuse	T 1.25 A / AC 250 V
Recommended backup fusing	16 A (for USA/Canada: 15 A)
Safety and protection/Environmental requirements	
Isolation voltage (pri.-sec./pri.-PE/sec.-PE)	2.47 kVAC / 3.92 kVAC / 0,5 kVDC
Protection class/ Protection type	I / IP20 (per EN 60529)
Overtoltage category	III (≤ 2000 m a. s.l.); II (> 2000 m a. s.l.)
Short-circuit-protected	Yes
Parallel operation/series operation	Yes/yes
MTBF	$> 2,500,000$ h (per IEC 61709 at $+40$ °C)
Ambient air temperature (operation)	-25 ... $+70$ °C (nominal mounting position; -20 ... $+55$ °C in any mounting position)
Relative humidity	5 ... 96 % (no condensation permissible)
Derating	-1.7 %/K (> 55 °C)
Pollution degree	2
Connection data	
Connection technology	Push-in CAGE CLAMP®
Input/signaling (solid/fine-stranded/AWG)	0.25 ... 2.5 mm ² / 0.25 ... 2.5 mm ² / 22 ... 12 AWG
Output (solid/fine-stranded/AWG)	0.2 ... 1.5 mm ² / 0.2 ... 1.5 mm ² / 24 ... 16 AWG
Physical data/ Mechanical data/ Material data	
Width x Height x Depth (mm)	36 x 90 x 62; depth from upper edge of DIN-rail: 55
Mounting type	DIN-35 rail
Weight	120 g
Standards and specifications	
Standards/Specifications	EN 61204-3; EN 61010-1; EN 61010-2-201; cULus 61010-1; cULus 61010-2-201, DNV

DALI Sensors



2852-7214

DALI Sensor		
	Item No.	PU
DALI Sensor; PD11-BMS-FLAT	2852-7210	1
DALI Sensor; PD4-BMS-GH	2852-7213	1
DALI Sensor; PD4N-BMS	2852-7214	1
Adapter; AP Assembly Kit IP54; Accessories for 2852-7214	2852-7215	1
DALI Sensor; MSensor G3 SRC 30 PIR 5DPI WH	2852-7220	1
DALI Sensor; IR Quattro HD DALI-2	2852-7230	1
DALI Sensor; IR Quattro SLIM XS DALI-2	2852-7231	1
DALI Sensor; IS3360 MX HIGH BAY DALI-2	2852-7232	1
DALI Sensor; IS345 MX HIGH BAY DALI-2	2852-7233	1



2852-7221

DALI Sensor		
	Item No.	PU
DALI Sensor; MSensor G3 SSM 30 10DPI WH	2852-7221	1
DALI XC Control Module with 4 Freely Programmable Inputs	2852-7225	1



2852-7225



2852-7601/000-001

Room Control Unit		
	Item No.	PU
Room Control Unit; Modbus®; RBG1; Display; Glass front; Aluminum frame; Black	2852-7601/000-001	1
Room Control Unit; Modbus®; RBG1; Display; Glass front; Aluminum frame; White	2852-7601/000-002	1

Room Control Units



2852-7110

Room Control Unit		
	Item No.	PU
WRF04-P Room Control Unit; Passive; Wall-Mount; Pt1000; 5 kOhm	2852-7110	1
WRF07-P Room Control Unit; Passive; Flush-Mount; Pt1000; 5 kOhm	2852-7111	1
SR04-P Room Control Unit; Radio; Wall-Mount; EnOcean	2852-7112	1
SR06-LCD Room Control Unit; Radio; Flush-Mount; EnOcean®; 2 Push-Buttons	2852-7113	1
WRF04-P-RS-485 Room Control Unit; Modbus®; Wall-Mount; Temperature; Set Point Value	2852-7114	1
WRF07-P-RS-485 Room Control Unit; Modbus®; Flush-Mount; Temperature; Set Point Value	2852-7115	1



2852-7510

Manually Operated Module		
	Item No.	PU
RBT10 Signaling Module; 12 LEDs	2852-7510	1
RBT20 Output Module; 4 Switches; 8 LEDs	2852-7511	1
RBT30 Output Module; 4 Push-Buttons; 4 LEDs + 12 LEDs	2852-7512	1
RBT40 Analog Module; 4 Rotary Encoders; 4 Bar Displays	2852-7513	1
RBT50 Operating Module; 2 Analog; 2 Digital	2852-7514	1



Connection Board		
	Item No.	PU
RBT-AK Connection Board for Robutec Series	2852-7515	1



Rack		
	Item No.	PU
RTR4050S Rack 4 HE, 50TE	2852-7516	1

Multi Port Device Taps for DeviceNet

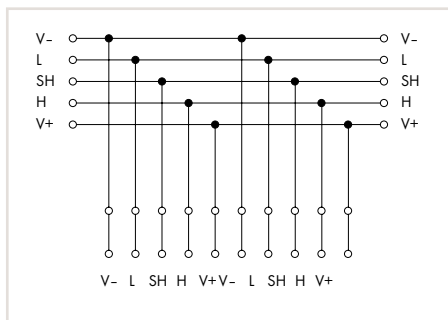

For DeviceNet, a terminating resistor must be connected to each end of the trunk cable. A metal film resistor with the following values must be used: 121 Ohm ± 1 %, ¼ W. Do not connect terminating resistors to the end of a drop cable, only connect to the ends of the trunk cable.

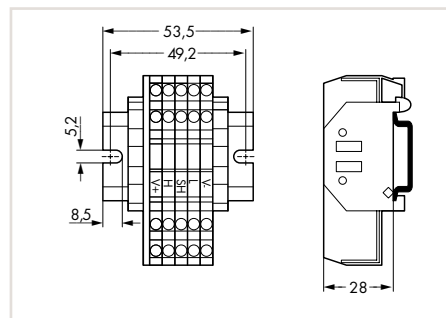
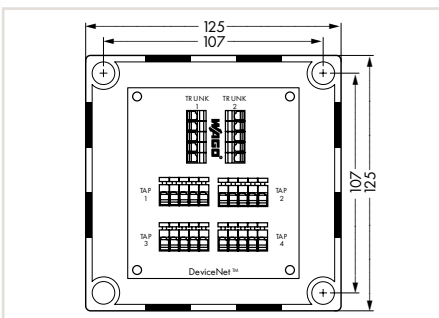

Item Description	Multi Port Device Tap; 2 trunk cables (input, output); 4 drop cables; Housing (IP65/NEMA 4)	Multi Port Device Tap; 2 trunk cables (input, output); 2 drop cables; Open style
Item No.	810-900/000-001	810-901/000-001

Technical Data	810-900/000-001	810-901/000-001
Wire connection for trunk cables	2 x 256-405 (PCB terminal blocks)	
Wire connection for drop cables	4 x 255-405 (PCB terminal blocks)	
Housing	With cable entry holes	
Terminal block		5 x 280-633
End terminal block		2 x 249-116
DIN-rail		DIN 35, slotted
Conductor cross-sections	0.08 ... 2.5 mm ² / 28 ... 12 AWG	0.08 ... 2.5 mm ² / 28 ... 12 AWG
Cable diameter (trunk cable)*	10 ... 14 mm Ø	
Cable diameter (drop cable)	6 ... 12 mm Ø	
Protection type (housing)	IP65/NEMA 4	
For data sheet and additional information, see:	wago.com/810-900/000-001	wago.com/810-901/000-001

Accessories	Item No.	PU	Item No.	PU
Cable grip for trunk cable 10 ... 14 mm Ø	810-900/001-000	1		
Cable grip for drop cable 6 ... 12 mm	810-900/002-000	1		
Terminating resistor	810-900/003-000	200	810-900/003-000	200
Test adapter for miniature banana plug	810-900/004-000	1	810-901/001-000	1

*when using the cable grip (available as accessories)

Multi Port Device Taps for DeviceNet



For DeviceNet, a terminating resistor must be connected to each end of the trunk cable. A metal film resistor with the following values must be used: 121 Ohm ± 1 %, ¼ W. Do not connect terminating resistors to the end of a drop cable, only connect to the ends of the trunk cable.

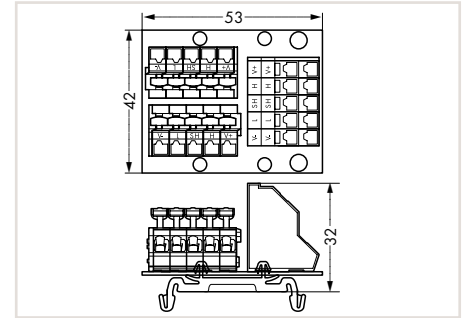
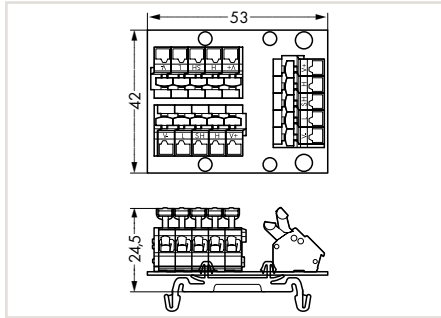

Item Description	Multi Port Device Tap with Mounting Foot; 2 trunk cables (input, output); 1 drop cable; Open style		Multi Port Device Tap with Mounting Foot; 2 trunk cables (input, output); 2 drop cables; Open style	
Item No.	810-902/000-001		810-902/000-002	
Technical Data				
Wire connection for trunk cables	2 x 5 x 256 Series (PCB terminal blocks)		2 x 5 x 256 Series (PCB terminal blocks)	
Wire connection for drop cables	1 x 5 x 256 Series (PCB terminal blocks)		1 x 5 x 736 Series (PCB terminal blocks)	
Conductor cross-sections	0.08 ... 2.5 mm ² / 28 ... 12 AWG		0.08 ... 2.5 mm ² / 28 ... 12 AWG	
For data sheet and additional information, see:	wago.com/810-902/000-001		wago.com/810-902/000-002	
Accessories				
Terminating resistor	Item No.	PU	Item No.	PU
Test adapter for miniature banana plug	810-900/003-000	200	810-900/003-000	200
	810-901/001-000	1	810-901/001-000	1

Shield Connection System, 790 Series Application and Installation Instructions



Carrier with grounding foot* (790-113), 45 mm long, busbar 90° to the DIN-rail

*for all shield clamping saddle sizes



Carrier with grounding foot* (790-114), 45 mm long, busbar parallel to the DIN-rail

*for all shield clamping saddle sizes



Carrier with grounding foot* (790-115), 125 mm long, busbar parallel to the DIN-rail

*for all shield clamping saddle sizes



Securing a spacer sleeve to a specialty slotted DIN-rail.



Securing an additional shield clamping saddle.



Tightening/removing a shield clamping saddle.



After connection, tighten the knurled screw to complete the installation. Recommended tightening torque: 0.5 Nm



To remove the clamping saddle, unscrew until ratcheted mechanism is released, then slightly tip saddle and remove the clamping saddle.

Shield Connection System, 790 Series Application and Installation Instructions



Carrier with grounding foot – busbar parallel to the DIN-rail



Insulated mounting carriers for a common shield reference potential, independent of housing potential

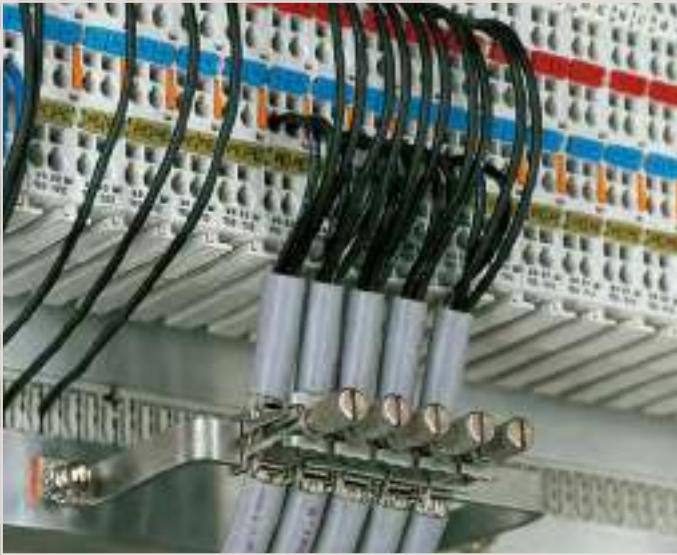

U-shaped (10 x 3) mm copper busbar

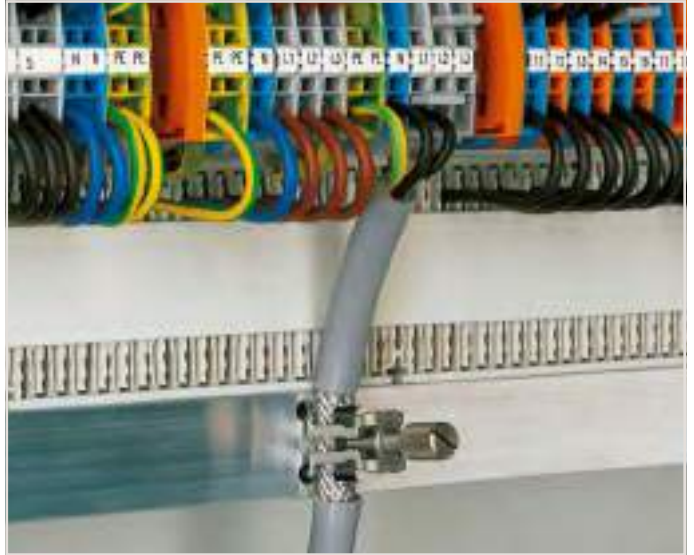

Snap shield clamping saddles into any metal plate (max. thickness: 3 mm).

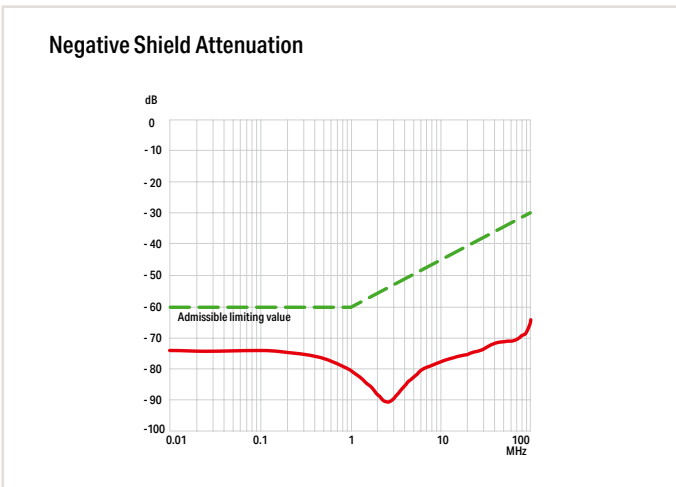

WAGO's shield connection system is highly effective because the clamping unit can be brought very close to the unshielded part of the cable.

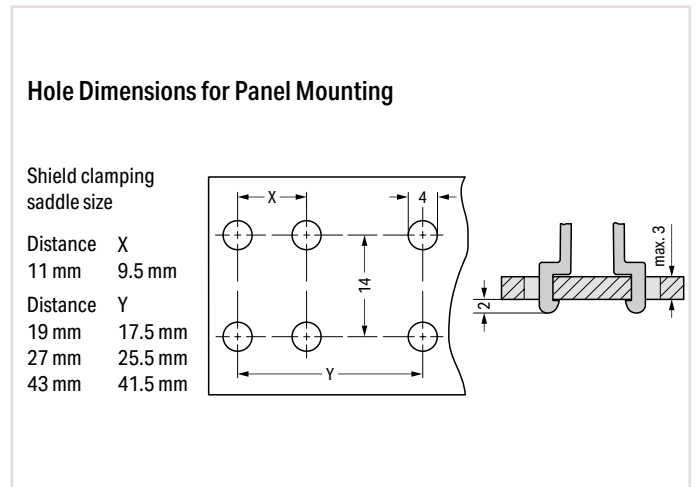

Additionally, the spring material is part of the clamping saddle, providing a good electrical connection (the system also acts as a partial strain relief). The spring element integrated in the shield clamping saddle compensates for deformation and settling that results from a connected shield.

Shield Clamping Saddles 790 Series



Shield clamping saddle; 11 mm wide; max. shield diameter of 8 mm		
Item No.	PU	
790-108	50 (10)	

Shield clamping saddle; 19 mm wide; 7 ... 16 mm shield diameter		
Item No.	PU	
790-116	50 (10)	

Shield clamping saddle; 27 mm wide; 6 ... 24 mm shield diameter		
Item No.	PU	
790-124	50 (10)	



Shield clamping saddle, 43 mm wide, 22 ... 40 mm shield diameter		
Item No.	PU	
790-140	50 (10)	

Installation

The shield clamping saddle is shipped ready for direct connection to the (10 x 3) mm busbar or a drilled mounting plate. After connection, tighten the knurled screw to complete the installation.
Maximum tightening torque: 0.5 Nm



Removal

To remove the clamping saddle, unscrew until ratcheted mechanism is released, then slightly tip saddle and remove the clamping saddle.



Delivery position for direct snapping

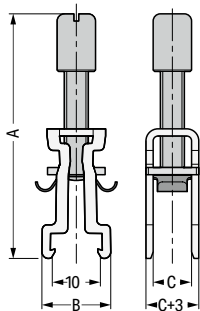

Snapping position closed

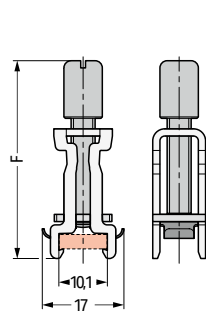

Release position

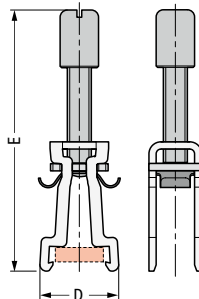

Dimensions in mm

Item No.	A	B	C	D	E	F
790-108	51	15	8	16	55	42
790-116	53	15	16	16	57	45
790-124	78	15	24	16	83	58
790-140	97	15	40	16	100	73

Spring-Equipped Shield Clamping Saddles 790 Series



Shield clamping saddle; 3 ... 8 mm diameter; 12.4 mm wide		
Item No.	PU	
790-208	50	



Shield clamping saddle; 6 ... 16 mm diameter; 21.8 mm wide		
Item No.	PU	
790-216	25	



Shield clamping saddle; 6 ... 20 mm diameter; 30 mm wide		
Item No.	PU	
790-220	25	



Mounting a clamping saddle on a specialty slotted DIN-rail (790-145).
When releasing the saddle, do not place your finger under the clamping spring!



Removing the shield clamping saddle.



Shield clamping saddle contacts shield conductor and specialty slotted DIN-rail (790-145).



Application example



Labeling using a marking strip.



Labeling using WMB markers.

Delivery position

Mounting position

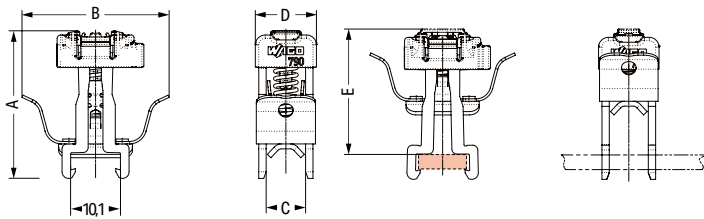

Dimensions in mm

Item No.	A	B	C	D	E*
790-208	30	29,9	8	12,4	25,8
790-216	34,6	28,3	16	21,8	30,2
790-220	45,6	28,3	24	30	41,2

*Height with WMB marker

Shield Clamps and Shield Terminations

791 and 709 Series



Shield clamp; 1.5 ... 6.5 mm shield diameter;
max. 40 mm high; 10 mm wide

Item No.	PU
791-107	50

Shield clamp; 5 ... 11 mm shield diameter;
max. 47 mm high; 17 mm wide

Item No.	PU
791-111	50

Shield clamp; 10 ... 17 mm shield diameter;
max. 63 mm high; 23 mm wide

Item No.	PU
791-117	50

Shield clamp; 16 ... 24 mm shield diameter;
max. 78 mm high; 30 mm wide

Item No.	PU
791-124	50



Shield termination; includes cable ties for 5 ... 10 mm shield diameter;
60 mm long

Item No.	PU
709-350	100 (25)

Shield termination; includes cable ties for 5 ... 10 mm shield diameter;
150 mm long

Item No.	PU
709-352	100 (25)



Insert the shield termination into the female plug using the operating tool.



Fit the shield termination to the shield cable.



Secure both shield cable and shield termination to the strain relief plate using cable ties.



Shield termination connected to an X-COM® Female Plug

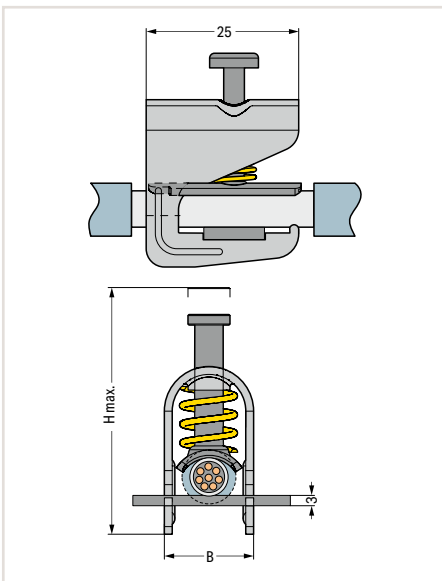

Dimensions in mm

Accessories for Shield Connection Systems

Item Description				Item No.	PU	
   	Carrier with Grounding Foot					
	Carrier with grounding foot; busbar parallel to the rail; 15 mm long; copper (10 x 3) mm; suitable for shield clamping saddles (790-108)		790-110		25	
	Carrier with grounding foot; busbar parallel to the rail; 25 mm long; copper (10 x 3) mm; suitable for shield clamping saddles (790-108; 790-116) and shield clamps (791-111; 791-117)		790-112		25	
	Carrier with grounding foot; busbar 90° to the DIN-rail; 45 mm long; copper (10 x 3) mm; suitable for shield clamping saddles (790 Series)		790-113		25	
  	Carrier with 2 Grounding Feet					
	Carrier with 2 grounding feet; busbar parallel to the DIN-rail; 125 mm long; copper (10 x 3) mm		790-115		25	
	Busbar					
	Busbar; tin-plated; 1000 mm long; copper (10 x 3) mm		210-133		1	
  	Busbar; tin-plated; 30 mm long; copper (10 x 3) mm		790-133		20	
	Busbar; tin-plated; 50 mm long; copper (10 x 3) mm		790-134		20	
	DIN-Rail; Specialty Slotted					
DIN-rail; specialty slotted; 1000 mm long; tin-plated		790-145		1		
Spacer sleeve; for DIN-rail; suitable for M5-size screw; specialty slotted		790-144		200 (100)		
	Insulated Mounting Foot					
	Insulated mounting foot; for busbar with M4 x 8 mm screw		790-100		50 (25)	
	Insulated mounting foot; for busbar with (3.5 x 9) mm sheet metal screw		790-101		50 (25)	
 	U-shaped Busbar; suitable for 750 Series I/O Modules					
		A	B	C		
	U-shaped busbar; copper (10 x 3) mm; for 5 I/O	63	60	83	790-190	25 (5)
	U-shaped busbar; copper (10 x 3) mm; for 8 I/O	100	60	118	790-191	25
	U-shaped busbar; copper (10 x 3) mm; for 5 I/O	63	35	83	790-192	25
	U-shaped busbar; copper (10 x 3) mm; for 8 I/O	100	35	118	790-193	25

Dimensions in mm

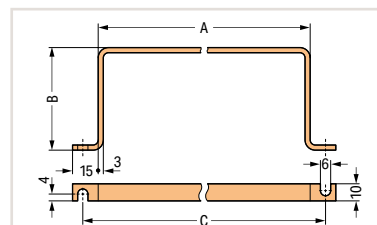

Busbar Carriers

790 Series



Dimensions in mm

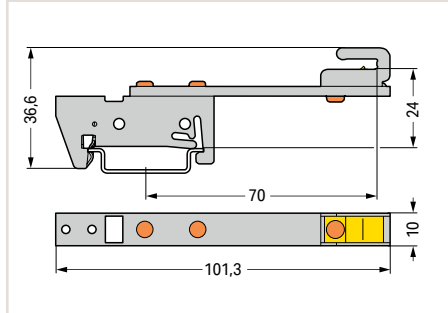

Busbar carrier; for (10 x 3) mm copper busbars; single side; straight; snaps onto DIN-35 rail

Item No.	PU
790-300	10

Dimensions in mm

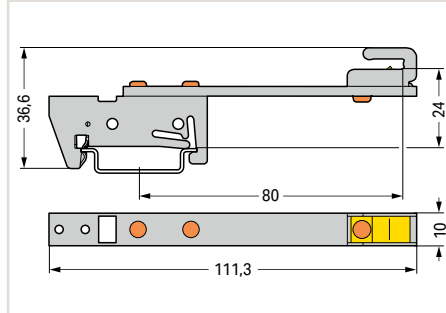

Busbar carrier; for (10 x 3) mm copper busbars; single side; straight; snaps onto DIN-35 rail

Item No.	PU
790-302	10

Dimensions in mm

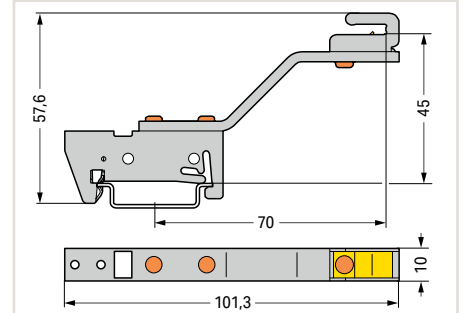

Busbar carrier; for (10 x 3) mm copper busbars; single side; angled; snaps onto DIN-35 rail

Item No.	PU
790-301	10



Dimensions in mm

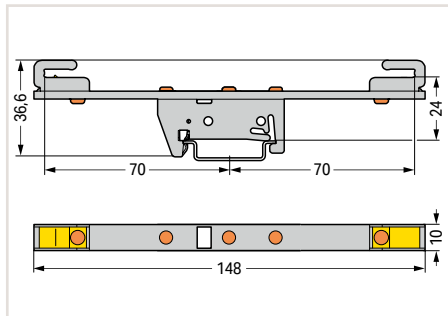

Busbar carrier; for (10 x 3) mm copper busbars; both sides; straight; snaps onto DIN-35 rail

Item No.	PU
790-310	10

Dimensions in mm

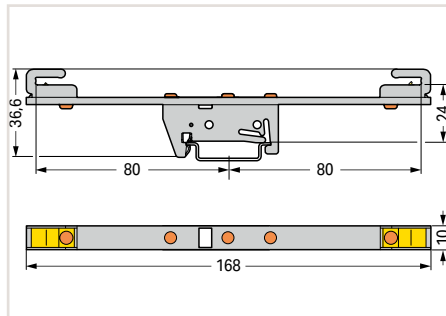

Busbar carrier; for (10 x 3) mm copper busbars; both sides; straight; snaps onto DIN-35 rail

Item No.	PU
790-312	10

Dimensions in mm

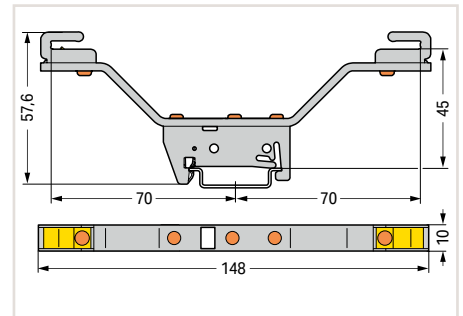

Busbar carrier; for (10 x 3) mm copper busbars; both sides; angled; snaps onto DIN-35 rail

Item No.	PU
790-311	10

Busbar Carriers

790 Series



Dimensions in mm

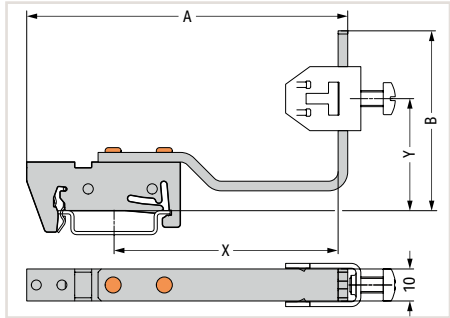

Busbar carrier; for (10 x 3) mm copper busbars; flexible; snaps onto DIN-35 rail		
Item No.	PU	
790-350/790-398	12	
790-352/790-398	12	
790-360/790-398	12	
790-362/790-398	25	



Dimensions in mm

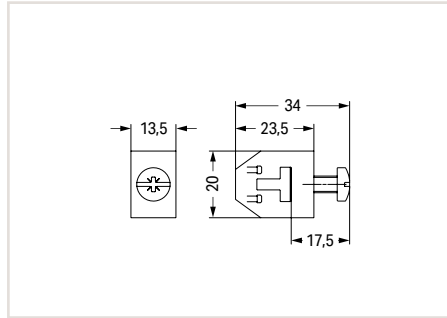

T-connector; for (10 x 3) mm copper busbars		
Item No.	PU	
790-398	10	



Dimensions in mm

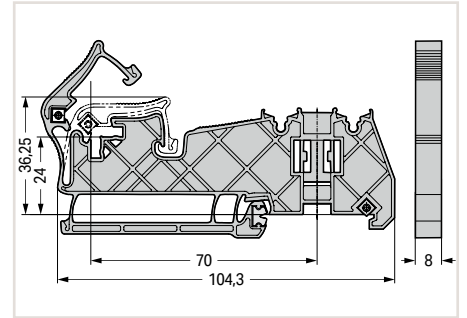

Busbar carrier; for (10 x 3) mm copper busbars; no contact to DIN-rail; insulated		
Color	Item No.	PU
gray	790-400	20

Dimensions in mm

Item No.	A	B	X	Y
790-350/790-398	100	56	70	15...52
790-352/790-398	100	99	70	15...92
790-360/790-398	115	56	85	15...52
790-362/790-398	115	99	85	15...92



Horizontal mounting position of the busbar



Horizontal mounting position of the busbar



Vertical mounting position of the busbar



Vertical mounting position of the busbar

Mini-WSB Marker Card; as Card and Mini-WSB Inline; for Smart Printer; on Reel

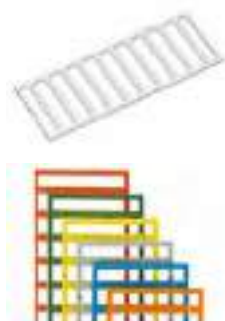

Mini-WSB Marker Card; as card; not stretchable; plain; snap-on type		
Color	Item No.	PU
white	248-501	5
yellow	248-501/000-002	5
red	248-501/000-005	5
blue	248-501/000-006	5
gray	248-501/000-007	5
orange	248-501/000-012	5
light green	248-501/000-017	5
green	248-501/000-023	5
violet	248-501/000-024	5



Mini-WSB Inline; for Smart Printer; on reel; stretchable 5 ... 5.2 mm; plain; snap-on type		
Color	Item No.	PU
white	2009-145	1



Mini-WSB Marker Card; as card; with marking; not stretchable; horizontal marking; snap-on type				
Marking	No. of Markings	Color	Item No.	PU
0 V	100x	blue	247-506/000-006	5
0 V	100x	white	247-506	5
-	100x	blue	247-507/000-006	5
-	100x	white	247-507	5
24 V	100x	red	247-508/000-005	5
24 V	100x	white	247-508	5
+	100x	red	247-509/000-005	5
+	100x	white	247-509	5
⊕	100x	light green	247-552/000-017	5
⊕	100x	white	247-552	5
GND	100x	light green	248-578/000-017	5
GND	100x	white	248-578	5
A0 A1 ... A8 A9	10x	white	247-510	5
E0 E1 ... E8 E9	10x	white	247-511	5
X0 X1 ... X8 X9	10x	white	247-512	5
00 ... 09	10x	white	247-513	5
10 ... 19	10x	white	247-514	5
20 ... 29	10x	white	247-515	5
30 ... 39	10x	white	247-516	5
40 ... 49	10x	white	247-517	5
50 ... 59	10x	white	247-518	5
60 ... 69	10x	white	247-519	5
70 ... 79	10x	white	247-520	5
80 ... 89	10x	white	247-521	5
90 ... 99	10x	white	247-522	5
00 ... 49	2x	white	247-523	5
50 ... 99	2x	white	247-524	5
100 ... 149	2x	white	247-525	5
150 ... 199	2x	white	247-526	5
200 ... 249	2x	white	247-527	5
250 ... 299	2x	white	247-528	5
300 ... 349	2x	white	247-529	5
350 ... 399	2x	white	247-530	5
400 ... 449	2x	white	247-531	5
450 ... 499	2x	white	247-532	5
500 ... 549	2x	white	247-533	5
550 ... 599	2x	white	247-534	5
600 ... 649	2x	white	247-535	5
650 ... 699	2x	white	247-536	5
700 ... 749	2x	white	247-537	5
750 ... 799	2x	white	247-538	5
800 ... 849	2x	white	247-539	5
850 ... 899	2x	white	247-540	5
900 ... 949	2x	white	247-541	5
950 ... 999	2x	white	247-542	5
.0 ... 7 / free	10x/20x	white	247-543	5
.0 ... 7 /-	10x/20x	white	247-544	5
.0 ... 7 /-	10x/20x	blue	247-544/000-006	5
.0 ... 7 /+	10x/20x	white	247-545	5
.0 ... 7 /+	10x/20x	red	247-545/000-005	5
.0 ... 7 /N	10x/20x	white	247-546	5
.0 ... 7 /N	10x/20x	blue	247-546/000-006	5
.0 ... 7 /L	10x/20x	white	247-547	5

Marker Card and Group Marker Carrier



Figure: 750-103

Marker Card; as DIN A4 sheet; plain		
	Item No.	PU
	750-100	1

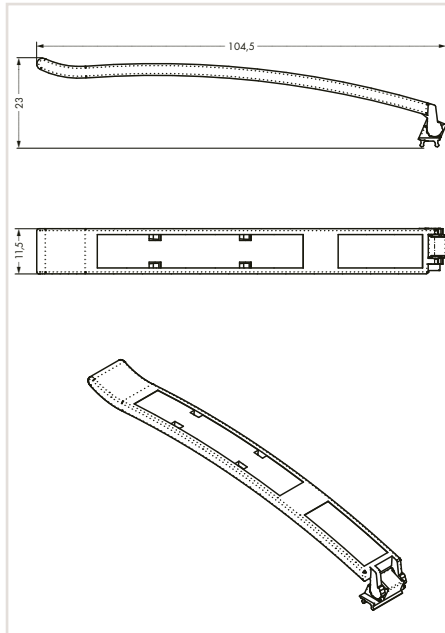

Figure: 750-106

Figure: 750-107

Item Description	
Item No.	750-103
Technical Data	
Dimensions W x D	11.5 x 104.5 mm
Material	Polycarbonate
Weight	2.84 g
For data sheet and additional information, see: wago.com/750-103	
Accessories	
Marking strip; on reel; 7.5 mm wide; not stretchable; plain, snap-on type	709-178
Marker Card; as DIN A4 sheet; plain	750-105
Marking strip; on reel; not stretchable; plain; snap-on type	
WMB Inline; for Smart Printer; on reel; stretchable 5 ... 5.2 mm; plain; snap-on type	

Group Marker Carrier	
Item No.	750-103
11.5 x 104.5 mm	
Polycarbonate	
2.84 g	
wago.com/750-103	
Item No.	
709-178	
750-105	

Group Marker Carrier	
4 LEDs (max.)	8/16 LEDs (max.)
750-106	750-107
Polycarbonate	
0.4 g	
wago.com/750-106 wago.com/750-107	
Item No.	
2009-110	
2009-115	



Steel DIN-Rails 210 Series



Dimensions in mm

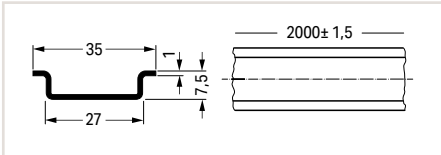

**Steel DIN-rail; unslotted;
IN 76 A (based on 1 m length);
35 x 7.5 mm; 1 mm thick; 2 m long**

	Item No.	PU
Per EN 60715	210-113	10
Continuously galvanized; per EN 60715	210-505	1



Dimensions in mm

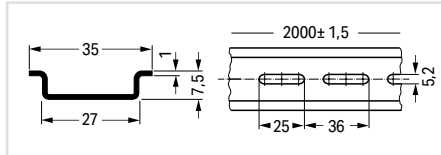

**Steel DIN-rail; slotted;
IN 76 A (based on 1 m length);
35 x 7.5 mm; 1 mm thick; 2 m long;
25 mm hole width; 36 mm hole spacing**

	Item No.	PU
Per EN 60715	210-112	10 (1)
Continuously galvanized; per EN 60715	210-504	1



Dimensions in mm

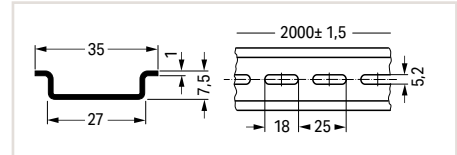

**Steel DIN-rail; slotted;
IN 76 A (based on 1 m length);
35 x 7.5 mm; 1 mm thick; 2 m long;
18 mm hole width; 25 mm hole spacing**

	Item No.	PU
Per EN 60715	210-115	1



Dimensions in mm

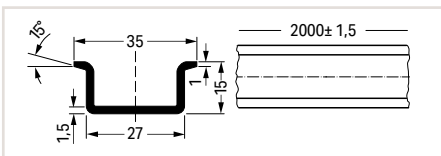

**Steel DIN-rail; unslotted;
IN 125 A (based on 1 m length);
35 x 15 mm; 1.5 mm thick; 2 m long**

	Item No.	PU
Similar to EN 60715	210-114	10
Continuously galvanized; similar to EN 60715	210-506	1



Dimensions in mm

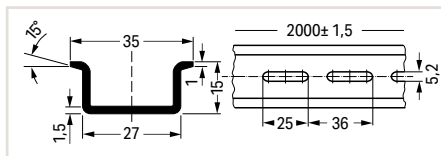

**Steel DIN-rail; slotted;
IN 125 A (based on 1 m length);
35 x 15 mm; 1.5 mm thick; 2 m long;
25 mm hole width; 36 mm hole spacing**

	Item No.	PU
Similar to EN 60715	210-197	10
Continuously galvanized; similar to EN 60715	210-508	1



Dimensions in mm

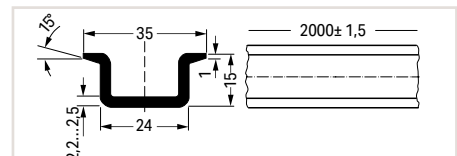

**Steel DIN-rail; unslotted;
IN 125 A (based on 1 m length);
35 x 15 mm; 2.3 mm thick; 2 m long**

	Item No.	PU
Per EN 60715	210-118	10

Aluminum DIN-Rail; Copper DIN-Rail; Angled Support Bracket; Rail End Cap 210 Series



Dimensions in mm

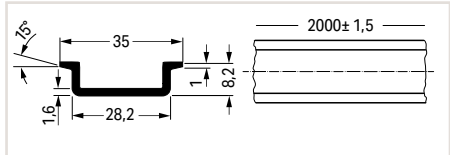

Aluminum DIN-rail; unslotted;
IN 76 A (based on 1 m length);
35 x 8.2 mm; 1.6 mm thick; 2 m long

	Item No.	PU
Similar to EN 60715	210-196	10



Dimensions in mm

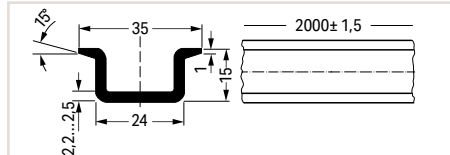

Copper DIN-rail; unslotted;
IN 309 A (based on 1 m length);
35 x 15 mm; 2.3 mm thick; 2 m long

	Item No.	PU
Per EN 60715	210-198	10



Dimensions in mm

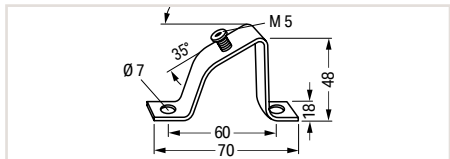

Angled support bracket

	Item No.	PU
Without screw	210-148	10
Screw M5 x 8	210-149	100 (20)



Rail end cap;
for DIN-35 rail (7.5 mm high)

Color	Item No.	PU
gray	209-109	50 (25)

Screwless End Stops 249 Series

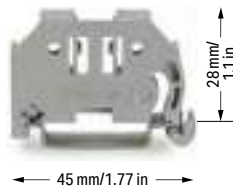

Screwless end stop; 6 mm wide		
Color	Item No.	PU
gray	249-116	100 (25)

Screwless end stop; 10 mm wide		
Color	Item No.	PU
gray	249-117	50 (25)



Screwless end stop; 14 mm wide		
Color	Item No.	PU
gray	249-197	10

Snap on – that's it! Assembling the new WAGO Screwless End Stop is as simple and quick as snapping a WAGO Rail-Mount Terminal Block onto the DIN-rail.

Tool free!

A tool-free design allows rail-mount terminal blocks to be safely and economically secured against any movement on all DIN-35 rails per DIN EN 50022 (35 x 7.5 mm; 35 x 15 mm).

Screwless!

The "secret" to a perfect fit lies in the two small clamping plates which keep the end stop in position, even if the rails are mounted vertically.

Simply snap on – that's it!

In addition, costs are significantly reduced when using large numbers of end stops.

Additional benefit: Three marker slots for all WAGO Rail-Mount Terminal Block Marking Systems and one snap-in hole for WAGO's adjustable height group marker carriers offer individual marking options.



Snapping an end stop onto the DIN-rail.



Removing an end stop from the DIN-rail.

Operating Tools and Cable Cutter 210 and 206 Series



Operating tool with a partially insulated shaft; Type 1; (2.5 x 0.4) mm blade		
Item No.	PU	
210-719	50 (1)	

Set of operating tools with a partially insulated shaft; Type 1; (2.5 x 0.4) mm blade; Type 2; (3.5 x 0.5) mm blade; Type 3; (5.5 x 0.8) mm blade		
Item No.	PU	
210-722	1	

Cable cutter; for copper and aluminum cables up to 35 mm ²		
Item No.	PU	
206-118	1	

Operating tool with a partially insulated shaft; Type 2; (3.5 x 0.5) mm blade		
Item No.	PU	
210-720	50 (1)	

Operating tool with a partially insulated shaft; Type 3; (5.5 x 0.8) mm blade		
Item No.	PU	
210-721	25 (1)	



The blade dimensions of the above-listed operating tools with a partially insulated shaft are ideal for easy operation of front-entry terminal blocks.



Cutting a cable.

Cable Knife 206 Series



Cable knife; for Ø 8 ... 28 mm / 0.31 ... 1.10 inch; with a unique, changeable cable bracket system; including cable bracket

Item No.	PU
206-1403	1



Cable knife set; for Ø 4 ... 70 mm / 0.16 ... 2.75 inch; including all cable brackets in a Sortimo® Box

Item No.	PU
206-1400	1

Never use this tool on or near live electrical circuits!



To replace the cable bracket, use the new bracket as an operating tool and pull it upwards.

Item-Specific Accessories

Cable bracket; for Ø 4 ... 16 mm / 0.16 ... 0.63 inch

206-1411	1
----------	---



Cable bracket; for Ø 8 ... 28 mm / 0.31 ... 1.10 inch

206-1412	1
----------	---



Cable bracket; for Ø 27 ... 35 mm / 1.06 ... 1.38 inch

206-1413	1
----------	---



Cable bracket; for Ø 35 ... 50 mm / 1.38 ... 1.97 inch

206-1414	1
----------	---



Cable bracket; for Ø 50 ... 70 mm / 1.97 ... 2.75 inch

206-1415	1
----------	---



Accessories

Spare inside blade

206-1418	1
----------	---



Spare hook blade

206-1419	1
----------	---



The cutting depth of the hook blade can be adjusted with the slider.



The cutting depth of the inner knife can be adjusted with the screw.



Strip large cross sections with the hook blade.



Release the fuse before using the hook blade.

Cable Strippers

206 Series



In-socket cable stripper; for Ø 8 ... 13 mm / 5/16 ... 1/2 inch

Item No.	PU
206-1441	1



Universal cable stripper; for Ø 8 ... 13 mm / 5/16 ... 1/2 inch

Item No.	PU
206-1442	1



Data cable stripper; for Ø 4.5 ... 10 mm / 3/16 ... 3/8 inch

Item No.	PU
206-1451	1



Product features:

- Extra-long design and improved force transmission simplifies stripping in deep device connection sockets
- Special four-blade design for an even more precise round cut
- No cutting depth adjustment required
- TiN-coated blades, TÜV/GS tested
- Ø 8 ... 13 mm / 5/16 ... 1/2 inch
- Strips all standard round cables, including NYM 3 x 1.5 mm²/16 AWG ... 5 x 2.5 mm²/14 AWG



Sheath stripping: longitudinal cut

Product features:

- Secure grip achieved with soft padding for non-slip grips
- Enhanced functionality
- New locking mechanism prevents the unwanted opening of the tool
- Absolutely straightforward, quick and easy longitudinal cuts – with innovative internal cable duct
- Redesigned blade layout and intake to stop cable waste from jamming the tool
- Durable and ergonomically designed pocket clip
- Ø 8 ... 13 mm / 5/16 ... 1/2 inch



Product features:

- Strip outer insulation and foil sheathing with one tool
- Ideal for stripping PVC-insulated data cables with thin insulation (e.g., Cat. 5, Cat. 6, Cat. 7, twisted pair cable)
- TiN-coated blades
- Ø 4.5 ... 10 mm / 3/16 ... 3/8 inch



Stripping a cable sheath.



Built-in handy knife



Stripping the conductor insulation.

Stripping Pliers 206 Series



Never use this tool on or near live electrical circuits!

The stripping pliers for sensor cables have a blade geometry specially designed for sensor cables with a smaller cross-section and a working range from Ø 3.2 mm / 0.13 inch (for stranded cables and round cables with Ø 3.2 mm ... 4.4 mm / 0.13 ... 0.17 inch).

The stripping pliers for control cables are designed for stronger cables from Ø 4.4 mm / 0.17 inch (for stranded cables and round cables with Ø 4.4 mm ... 7 mm / 0.17 ... 0.27 inch).

These stripping pliers quickly and safely strip cables for connecting, e.g., sensor/actuator distribution boxes, bus couplers and pluggable connectors.

Suitable for:

- Halogen-free PUR sensor/actuator cables
- Highly flexible TPE-U cables
- Control cables
- PUR cables
- PUR/PVC cables
- PVC cables
- Multi-core cables
- Shielded and unshielded cables

Stripping pliers; for sensor cables; for Ø 3.2 ... 4.4 mm / 0.13 ... 0.17 inch		
Item No.	PU	
206-1481	1	

Stripping pliers; for control cables; for Ø 4.4 ... 7 mm / 0.17 ... 0.27 inch		
Item No.	PU	
206-1482	1	

Item-Specific Accessories		
Replacement blade set; for Ø 3.2 ... 4.4 mm / 0.13 ... 0.17 inch		

206-1491	1	
----------	---	--

Item-Specific Accessories		
Replacement blade set; for Ø 4.4 ... 7 mm / 0.17 ... 0.27 inch		

206-1492	1	
----------	---	--



Wire Stripper 206 Series



Wire stripper "Quickstrip Vario"; 0.03 ... 16 mm² / 34 ... 6 AWG; with wire cutter

Item No.	PU
206-1125	1

Accessories

Blade set; Standard; 0.03 ... 16 mm² / 34 ... 6 AWG

206-1126 1



Blade set; V-blade; 0.14 ... 4 mm² / 24 ... 12 AWG

206-1127 1



Blade set; Oval blade; 10 ... 16 mm² / 8 ... 6 AWG

206-1128 1



Spare stripping stop

206-1129 1



Spare cut protector

206-1131 1



Spare clamping jaws

206-1132 1



Cutting a conductor.



Partially stripping a conductor.

Wire Stripper:

- Automatically adjust to conductor size
- Stripping blades don't damage conductor strands
- Gripping pressure of jaws adjusts automatically to conductor insulation diameter
- Clamping jaws and stripping blades automatically open once the stripping process is completed – no splaying of the conductor strands
- Exact strip length may be set by sliding black setting stop
- Stripping blades can be replaced
- Self-sharpening, fully protected cutter (replaceable)
- Entire body made of glass-fiber-reinforced polyamide
- Cutting capacity of the wire cutter of fine-stranded conductors up to 16 mm² (6 AWG)

Crimping Tools 206 Series



"Variocrimp 4" crimping tool; for insulated and uninsulated ferrules; crimping range: 0.25 ... 4 mm² (24 ... 12 AWG)

Item No.	PU
206-1204	1

"Variocrimp 16" crimping tool; for insulated and uninsulated ferrules; crimping range: 6 mm² (10 AWG), 10 mm² (8 AWG) and 16 mm² (6 AWG)

Item No.	PU
206-1216	1

Item-Specific Accessories

Spring clamp; large

	206-1205	1
--	----------	---

Spring clamp; small

	206-1206	1
--	----------	---

Item-Specific Accessories

Spring clamp; small

	206-1206	1
---	----------	---

Application notes:

- The built-in crimping pressure control of "Variocrimp 4" automatically adjusts the crimping force to the conductor cross-section. Select the wire gauge on "Variocrimp 16" before crimping.
- Only one crimping station is needed to handle the specified conductor range.
- Uniform, compact crimping on all four sides for high conductor retention.
- No need to center the ferrules into the terminal blocks.
- Crimping can be performed from either side (for left- or right-handed users).
- Built-in ratchet mechanism ensures gas-tight crimp connection.
- Crimping tools open automatically after crimping operation is complete.
- Ergonomically designed handles.



Insert the ferruled conductor into the crimping station.



Squeeze handles until ratchet mechanism is released.



A perfect gas-tight crimp – both electrically and mechanically reliable



Only for "Variocrimp 16":
Adjust conductor cross-section with crimping tool in open position.

Crimping Tools 206 Series



Crimping tool 25; for insulated and uninsulated ferrules; crimping range: 10 mm² (8 AWG), 16 mm² (6 AWG) and 25 mm² (4 AWG)

Item No.	PU
206-1225	1



Crimping tool 50; for insulated and uninsulated ferrules; crimping range: 35 mm² (2 AWG) and 50 mm² (1/0 AWG)

Item No.	PU
206-1250	1



Insert the ferruled conductor into the crimping station.



Squeeze handles until ratchet mechanism is released.

Application notes:

- Improved crimping for higher conductor retention
- Crimping can be performed from either side (for left- or right-handed users).
- Built-in ratchet mechanism ensures gas-tight crimp connection.
- Crimping tools open automatically after crimping operation is complete.
- Ergonomically designed handles.

What is a "gas-tight" connection?

In a gas-tight connection, the conductor and the ferrule are compressed, eliminating all spaces. Under normal atmospheric conditions, neither a liquid nor gaseous medium can penetrate the crimped connection.

Oxidation between crimped single conductors is prevented, virtually eliminating the possibility of any increase in the crimped connection's resistance. In some exceptional cases, minute, isolated spaces may be present. However, these instances can be considered as closed off due to the twisted conductor.

Inadequate crimping can allow the conductor to be pulled out of the connection. Hollow spaces also remain, permitting oxidation formation and an increase in contact resistance.

Elevated resistance is detrimental for both signal transmission (signal flow is damped) and power transmission, resulting in power loss and contact heating (risk of fire). Crimping tools with built-in ratchets are recommended (e.g., WAGO Crimping Tools). These tools open automatically after the crimping operation is complete. Space-saving crimping from all four sides is ideal for spring clamp termination.

Ferruled conductor cross-sections specified for WAGO products are based on this crimping method.

Test and Measurement Devices

206 Series



Profi-LCD+; 2-pole voltage tester with LCD display;
removable 4 mm Ø test probes

Item No.	PU
206-707	1



Profi-LED+; 2-pole voltage tester with LED display;
removable 4 mm Ø test probes

Item No.	PU
206-706	1



Spare test probes; 4 mm Ø (2 pieces)

Item No.	PU
206-808	25



Additional Profi-LCD+ features:

- Automatic measurement range selection
- Single-pole phase testing AC >100 V
- Two-pole sequence testing (R and L)
- Continuity testing
- RDC/RCD testing (30 mA) via buttons
- One-hand operation for SCHUKO® and CEE sockets
- LED torch lamp function
- Automatic backlight
- Auto power-off function
- CAT IV 1000 V
- TÜV/GS tested and approved
- IEC/EN 61243-3 (DIN VDE 0682-401)



Additional Profi-LED+ features:

- Automatic measurement range selection
- Single-pole phase testing AC >100 V
- Two-pole sequence testing (R and L)
- Continuity testing
- RDC/RCD testing (30 mA) via buttons
- One-hand operation for SCHUKO® and CEE sockets
- LED torch lamp function
- CAT IV 1000 V
- TÜV/GS tested and approved
- IEC/EN 61243-3 (DIN VDE 0682-401)



Profi-LED+:

- Improved socket contact via 4 mm Ø test probes
- Removable test probes for small test ports (suitable for all WAGO Terminal Blocks)



Test and Measurement Devices

206 Series



Testboy; with integrated flashlight, non-contact voltage tester

Item No.	PU
206-804	1



A device that will reliably detect AC voltage in cables, sockets, fuses, switches, outlets and other installations.

Testboy can detect the following:

- Live conductors
- Cable breaks
- Blown fuses (in cartridges or holders)
- Defective switches
- Defective lamps in strings of lights

WAGO GmbH & Co. KG

Postfach 2880 · D · 32385 Minden
Hansastraße 27 · D · 32423 Minden

info@wago.com

www.wago.com

Headquarters	+49 571 887 - 0
Sales	+49 571 887 - 44222
Order Service	+49 571 887 - 44333

Current addresses at www.wago.com

WAGO is a registered trademark of WAGO Verwaltungsgesellschaft mbH.

"Copyright – WAGO GmbH & Co. KG – All rights reserved.

The content and structure of the WAGO websites, catalogs, videos and other WAGO media are subject to copyright. Distribution or modification to the contents of these pages and videos is prohibited. Furthermore, the content may neither be copied nor made available to third parties for commercial purposes. Also subject to copyright are the images and videos that were made available to WAGO GmbH & Co. KG by third parties."